



PRONAUTIC
MARINE EQUIPMENT

RECAMBIOS para MOTORES **FUERABORDA 2023**

JOHNSON / EVINRUDE - MERCURY / MARINER
YAMAHA - SUZUKI - TOHATSU - HONDA

CONDICIONES DE LA GARANTIA SIERRA PARA CLIENTES PROFESIONALES

Todos los productos Sierra están garantizados en caso de piezas defectuosas, dicha garantía se regirá por las siguientes condiciones.

Todos los componentes **Sierra** que originalmente hayan sido instalados por un mecánico profesional y estén defectuosas, la pieza será abonada así como los gastos asociados que haya podido generar el cambio de dicha pieza.

La mano de obra se calculará basándose en los tiempos de recambio establecidos y fijados para cada componente.

Para tramitar la garantía el primer paso es devolver el recambio defectuoso indicando la referencia, la fecha de compra y el fallo detectado. Una vez sea recibido por Pronautic nosotros lo enviaremos a Sierra.

En el caso que hayan gastos asociados, mano de obra etc.. se deberán detallar en el momento de la devolución del material físicamente. Es imprescindible reclamar todo los gastos en el momento de la devolución física del material.

En dicho escrito deberá detallarse:

- 1- Todos los componentes utilizados para la reparación en garantía.
- 2- Las horas de mano de obra detalladas. Detallar las horas manos de obra en los recambios reemplazados.
- 3- Año, modelo y número de serie del motor.
- 4- Nombre y dirección del distribuidor donde se adquirió la pieza.
- 5- Nombre y dirección del cliente final.
- 6- Cualquier otra información adicional.

Excepciones de la garantía:

En los siguientes casos la garantía quedaría invalidada:

- a- Instalación y uso incorrecto. Cuando se instalen productos en una aplicación no detallada en nuestro catálogo.
- b- Artículos modificados.
- c- Incorrecto mantenimiento.

Para más información contacte con el departamento de recambios.

recambios@pronautic.net

ÍNDICE ALFABÉTICO

**GUÍA RÁPIDA POR MARCAS DE MOTOR/COMPETENCIAS COMPONENTES
 VARIOS MARCAS DE MOTORES FUERABORDA**

HONDA (Pág.355 a 371)	
Cruce de referencias Honda original/Pronautic	387-388
Hélices Honda	371
Cruce de referencias hélices Honda original/Pronautic	371
Bujías	368-369
JOHNSON / EVINRUDE (Pág. 136 a 247)	
Cruce de referencias original Johnson/Evinrude /Pronautic	388
Hélices BRP-Johnson-Evinrude	246 a 247
Cruce de referencias hélices Johnson/Evinrude /Pronautic	246 a 247
Bujías	239 a 245
MERCURY / MARINER (Pág. 23 a 135)	
Cruce de referencias original Mercury/Mariner /Pronautic	389-404
Hélices Mercury/Mariner	134-135
Cruce de referencias hélices Mercury/Mariner /Pronautic	134-135
Bujías	126 a 133
SUZUKI (Pág. 333 a 354)	
Cruce de referencias original Suzuki/Pronautic	411-412
Hélices Suzuki	352 a 354
Cruce de referencias hélices Suzuki original/Pronautic	352 a 354
Bujías	348 a 351
NISSAN / TOHATSU (Pág.373 a 383)	
Cruce de referencias original Tohatsu/Pronautic	412
Hélices Tohatsu	381 a 383
Cruce de referencias hélices Tohatsu original/Pronautic	381 a 383
Bujías	379-380
YAMAHA (Pág. 249 a 332)	
Cruce de referencias original Yamaha/Pronautic	414 a 417
Hélices Yamaha	331-332
Cruce de referencias hélices Yamaha/Pronautic	331-332
Bujías	327 a 330
COMPETENCIAS	
GLM Cruce de referencias GLM/Pronautic	387
VARIOS	
Aceites y Lubricantes	15-16
Motores Fueraborda HIDEA	17 a 22
HONDA (Pág.355 a 371)	
HONDA FUERABORDA (Pág. 355 a 371)	
Combustible Honda (Pág.357-358)	
Conector de combustible	358

Bombas manuales de combustible (peras)	357
Filtros de combustible/kits	358
Lineas de combustible	357
Componentes internos Honda (Pág. 365)	
Cojinetes	365
Filtros de aceite	365
Juntas	365
Electricidad Honda (Pág. 356)	
Motores de arranque	356
Motores Trim/tilt	356
Encendido Honda (Pág. 355)	
Cables bujías/kits	355
Refrigeración Honda (Pág. 360 a 365)	
Impulsores/kits de reparación	360
Tabla de identificación modelos Honda (Pág.355)	
Transmisión Honda (Pág.366 a 371)	
Ánodos	366-367
Hélices	370-371
Kits de retenes	367
Retenes de aceite	367
Tuercas de hélices/kits	367
JOHNSON / EVINRUDE (Pág. 136 a 247)	
Combustible Johnson/Evinrude (Pág.152 a 160)	
Bombas de combustible/kits	155-156
Bombas manuales de combustible (peras)	160
Conectores de combustible	160
Filtros de combustible	159
Kits carburador y productos relacionados	152-153
Líneas de combustible	160
Manguera de combustible	160
Separadores agua/combustible y soportes	158-159
Componentes internos Johnson/Evinrude (Pág.178 a 201)	
Bielas	181
Cojinetes/kits	181-182
Filtros de aceite	186
Juntas de culata	191-192
Juntas/Juegos	186 a 201
Pistones/Aros	178 a 181
Retenes cigüenal	185
Electricidad Johnson/Evinrude (Pág.145 a 152)	
Motores de arranque	149 a 151

Motores Trim/Tilt	145
Rectificadores/reguladores	148
Solenoides	146
Stators	145
Encendido Johnson/Evinrude (Pág.137 a 145)	
Bobinas	138
Bujías	239 a 245
Cableados bujías/Kits	143-144
Cajas de encendido	140 a 142
Condensadores	137
Juegos de contactos	137
Kits de encendido	137
Refrigeración Johnson/Evinrude (Pág.162 a 177)	
Despieces	176
Bombas de agua alojamiento/Kits	164 a 170
Impulsores/Kits	162 a 165
Termostatos/Kits	175
Tabla identificación modelos Johnson/Evinrude (Pág.136-137)	
Sistema de arranque Johnson/Evinrude (Pág.201)	
Cuerda de arranque	201
Muelles de arranque	201
Uña arranque	201
Transmisión Johnson/Evinrude (Pág.202 a 247)	
Ánodos	225 a 227
Arandelas/Espaciadores	212,215 y 224
Aros	235 a 238
Cables de acelerador	224
Cojinetes acoplamiento y retenedores	215-216
Colas y alojamientos	216
Despieces	202 a 211
Ejes hélice	219
Ejes transmisión	218
Engranajes/juegos	220-221
Hélices	246-247
Retenes de aceite	232 a 234
Retenes/Kits	228 a 230
Tuercas hélices/Kits	213
MERCURY / MARINER (Pág. 23 a 135)	
Combustible Mercury/Mariner (Pág.43 a 58)	
Bombas de combustible/Kits	49 y 53
Bombas de combustibles (peras)	51-52

Conectores de combustible	53
Filtros de aire	58
Filtros de combustible	57-58
Kits de carburador	43 a 45
Líneas de combustible	51
Separadores agua/combustible soporte	55 a 57
Componentes internos Mercury/Mariner (Pág.70 a 94)	
Cojinetes	73-74
Filtros de aceite	78
Juntas de culata	85-86
Juntas/juegos	79-93
Pistones/aros	70 a 77
Silentblocks	78
Electricidad Mercury/Mariner (Pág.30 a 43)	
Alternadores	39
Correas	39
Motores de arranque	39 a 42
Motores Tilt/trim	31,32 y 39
Reguladores de voltaje	35
Reles	36
Solenoides	35-36
Stators	32-33
Triggers	33
Encendido Mercury/Mariner (Pág.24 a 30)	
Bobinas	25-26
Bujías	30
Cableados bujías/kits	29-30
Cajas interruptor	26
Condensadores	25
Kits de encendido	24
Llaves de arranque	30
Refrigeración Mercury/Mariner (Pág.58 a 69)	
Bombas de agua alojamientos/kits	61 a 65
Impulsores/kits de reparación	59 a 62
Termostatos/kits	58-59
Tabla identificación Mercury/Mariner (Pág.23-24)	
Arranque Mercury/Mariner(Pág.94)	
Cuerdas de arranque	94
Muelles	94
Transmisión Mercury/Mariner (Pág.96 a 135)	
Ánodos/kits	110 a 112

Aros	121 a 125
Cojinetes/kits	102-103
Colas/carcasas	107
Despieces	96 a 101
Ejes de hélice	106
Ejes	106
Engranajes/juegos	106-107
Hélices	134-135
Kits de retenes	113 a 117
Mangueras/latiguillos Power Trim	109
Retenes de aceite	118 a 120
Tuercas hélices/kits	108-109
NISSAN / TOHATSU (Pág.373 a 383)	
SUZUKI (Pág. 333 a 354)	
Combustible Suzuki (Pág.335 a 339)	
Kits de carburador	335-336
Bombas manuales de combustible (peras)	337
Conectores de combustible	337-339
Filtros de combustible	336
Separadores agua/combustible	336
Componentes internos Suzuki (Pág.342-343)	
Bielas	342
Cojinetes	342
Filtros de aceite	343
Juntas de culata	343
Electricidad Suzuki (Pág.334-335)	
Motores de arranque	334
Motor tilt/trim	335
Encendido Suzuki (Pág.333)	
Bujías	348 a 350
Cable de bujías/kits	333
Refrigeración Suzuki (Pág.339 a 341)	
Impulsores/kits	339-340
Juntas bombas de agua	340-341
Tabla de identificación modelos Suzuki (Pág.333)	
Transmisión Suzuki (Pág.344 a 354)	
Ánodos	344-345
Aros	347
Hélices	352 a 354
Retenes de aceite	347
Retenes unidad inferior/kits	345 a 347
Tuercas para hélice/kits	344

Combustible Yamaha (Pág.259 a 271)

Bombas de combustible (Peras)	271
Conectores de combustible	271
Diafragmas bombas de combustible	263-264
Filtros de combustible	267 a 269
Filtro separadores de agua/combustible	265-266
Líneas de combustible	270
Kits de carburador	259-260

Componentes internos Yamaha (Pág.292 a 307)

Aros	292
Bielas/kits	293
Cojinetes/Kits	293
Filtros de aceite	293-294
Juntas/kits	294 a 307
Juntas de culata	297
Pistones	292-293

Electricidad Yamaha (Pág.253 a 259)

Motores de arranque	253 a 255
Motores Trim/tilt	255 a 258

Encendido Yamaha (Pág.249 a 253)

Bobinas	249-250
Bujías	327 a 330
Cables bujía/kits	251

Refrigeración Yamaha (Pág.272 a 291)

Alojamientos bomba de agua/kits	273 a 283
Impulsores/kits	271

Tabla identificación modelos Yamaha (Pág.249)

Transmisión Yamaha (Pág.308 a 332)

Ánodos	309-310
Aros	326
Cojinetes	308
Despieces	312 a 321
Ejes de hélice	308
Hélices	331-332
Retenes kits	322 a 325
Retenes aceite	326
Tuercas de hélice/kits	310-311

HERRAMIENTAS

			REF. SIERRA	REF. MERCURY
	HINGE PIN TOOL	Reemplaza: Mercury 91-78310. Para el montaje y extracción de hinge pins de todas las colas Mercury.	18-9861	91-78310
	SPANNER NUT WRENCH	Reemplaza: Mercury 91-17256. Para el montaje y extracción de cojinetes retenedores de las colas MC-I,R-MR,Blackhawk,todas las Bravo y Alpha I.	18-9803	91-17256
	HERRAMIENTA FUELLES	Reemplaza: 91-45497A1. Para el montaje de fuelles de escape de colas MC-I,R-MR,Alpha One,Bravo uno y dos y Blackhawk.	18-9847	91-45497 A1
	LLAVE HELICE	Reemplaza: 91-821887A1,91-859046Q4 y 91-859046T4.	18-4459	91-859046q4
	LLAVE COJINETES	Reemplaza: 91-61069T. Para la instalación y extracción de cojinetes en colas Bravo Uno y dos,MC-I,R-MR,Alpha One,Alpha One/Gen II,TRS y fuerabordas.	18-9858	91-61069T
	ADAPTADOR TUERCA PIÑON	Reemplaza:91-61067A3.	18-9857	91-61067A04
	DRIVE GEAR SHIMMING TOOL	Reemplaza:91-60526T.	18-9856	91-60526T
	DRIVE SHAFT RETAINER WRENCH	Reemplaza: 91-43506T. Para la instalación y extracción de cojinetes en colas Alpha y fuerabordas.	18-9842	91-43506t
	ADAPTADOR EJE TRANSMISION	Reemplaza: 91-61077. Llave para girar el eje de la helice en las colas MC-I,R-MR,Alpha One,Alpha One/GenII, Bravo One y TRS.	18-9868	91-61077T
	TOMA DE AGUA	Para la limpieza de circuitos de refrigeración de motores con colas.	18-9010	
	HERRAMIENTA COJINETE	Reemplaza: 91-17257.	18-9809	91-17257

HERRAMIENTAS

			REF. SIERRA	REF. MERCURY
	HERRAMIENTA CABLE CAMBIO	Para instalar y extraer cables de cambio de MC-I,R-MR,Alpha One/Gen II. Reemplaza: Mercruiser 91-12037	18-9806E	
	LLAVE CAZOLETA	Reemplaza: Racor RK22628. Para cazoletas Sierra,Racor y otras marcas.	LLAVE 18-9884 CAZOLETA 18-7987	
	BARRA PARA ALINEAR MOTORES	MERCUISER/ALPHA ONE	18-4442	
	TESTER COMPROBACIÓN CHISPA	4 CILINDROS	18-8960	
	AC/DC 600A CLAMP METER	Para la medicion de corriente AC/DC con una desviacion minima de 0.1A hasta 600A. Ideal para testear motores electricos,bombas de combustible,sistemas de carga,alternadores etc.	18-9908	
	KIT ABRAZADERAS	Reemplaza: 787133,787145.	189125	
	HERRAMIENTA AJUSTE CABLE CAMBIO	Reemplaza:Mercury 91-12427,91-12427T	18-9807	
	HERRAMIENTA PUESTA A PUNTO	Reemplaza: Mercury 91-99379. Comprueba la puesta a punto del encendido. Equipado con dos baterias portatiles.	18-9802	
	MAQUINA ELECTRONICA MEDIDOR DE COMPRESIONES		18-9900	



HERRAMIENTA DE DIAGNOSIS PARA MOTORES MARINOS Y ESTACIONARIOS (GENERADORES)

- Cobertura multimarca y multisistema en motores intraborda, motores fueraborda y motos de agua
- Diagnóstico completo con descripción detallada de los códigos de error
- Funciones de diagnóstico avanzadas: Calibraciones, Parametrizaciones y Memorización de llaves para motos de agua
- Detección automática de sistemas (Motor, Control de timón, Control de colas, Tren de propulsión, Frenos y marcha atrás, Instrumentación...)
- Información técnica integrada y esquemas eléctricos
- Datos de mantenimiento y de servicio
- Programa de actualizaciones definido
- Integración rápida de las novedades del mercado en nuestro software
- Interfaz de software rápida, intuitiva y fácil de usar
- Call-center para soporte técnico y de producto
- Formación
- GRP-Gestión de taller

RESUMEN DE PRODUCTOS:

	TIPO			
BARCO				
COMPLETO				
INTRABORDA				
FUERABORDA				
MOTO AGUA				

Cobertura

Intraborda:

CATERPILLAR
 CRUSADER
 CUMMINS
 CUMMINS MerCruiser Diesel
 ILMOR
 INDMAR
 IVECO-FPT
 JOHN DEERE
 MAN
 MERCURY MerCruiser
 MERCURY Racing
 MTU
 PCM
 SCANIA
 SCARAB
 SEA-DOO (BRP)
 STEYR
 VM MOTORI
 VOLKSWAGEN
 VOLVO PENTA
 WEBER
 YANMAR

Fueraborda:

EVINRUDE
 HONDA
 JOHNSON
 MARINER
 MERCURY
 MERCURY Racing
 NISSAN
 SELVA
 SUZUKI
 TOHATSU
 YAMAHA

Motos:

HSR-BENELLI
 KAWASAKI
 SEA-DOO (BRP)
 YAMAHA

Motores estacionarios:

CATERPILLAR
 CUMMINS
 DETROIT DIESEL-MBE
 DEUTZ
 DOOSAN
 HINO
 ISUZU
 IVECO-FPT
 JCB
 JOHN DEERE
 KOHLER
 KUBOTA
 LIEBHERR
 MAN
 MERCEDES-BENZ
 MTU
 PERKINS
 SCANIA
 SISU
 STEYR
 VM MOTORI
 VOLVO PENTA
 YANMAR

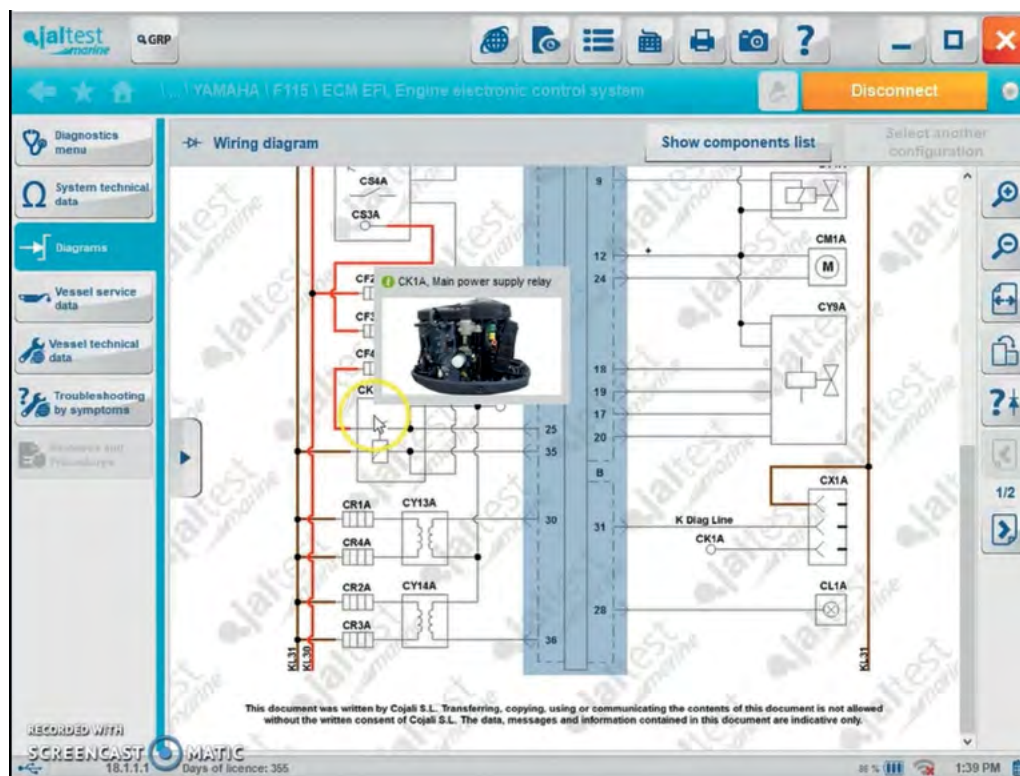

**EN EL MERCADO DE LA DIAGNOSIS MARINA
 desde 2002**

Solicita una visita con demo incluida.



Primers Spray

Fondo antioxidante de bajísima nocividad, alta resistencia a los arañazos, óptima adhesividad. Rociando sobre las superficies uniforma la sucesiva pintura, aumentando la resistencia. Metalzinc producto que permite efectuar sin ninguna herramienta especial un verdadero proceso de cincado en frío garantizando un perfecto revestimiento protector de la superficie tratada, con posibilidad de sobreponer esmalte y pinturas. Envases de 400ml.

Referencia	Aplicación	Color
101239	Anti-rust	Gris.
101240	Metal-zinc	Gris.
101251	Fosfozinc	verde



Antifoulings

Barniz antiincrustante para la protección de los pies de popa, de las hélices y colas en un cómodo envase spray. No contiene compuestos de estaño y cobre pero desarrolla su acción liberando venenos orgánicos no contaminantes. Antiincrustante de matriz dura adecuada para la velocidad media y alta. Envases de 400ml.

- 101205 Transparente
- 101206 Blanco
- 101207 Negro
- 101208 Gris

Pinturas para Colas y Motores Fueraborda

Barniz spray de rápida desecación. Fuerte resistencia a los agentes atmosféricos. Disponible en varios colores y envases de 400ml.



Referencia	Aplicación	Color	Referencia	Aplicación	Color
101209		● Transparente	101230	Volvo	● Rojo
101210	Evinrude	● Plata 84	101231	OMC	● Azul Colas
101211	Yanmar	● Gris	101232	Yamaha	● Azul Metalizado 74-85
101212	Caterpillar	● Amarillo	101233	Yamaha	● Gris Metalizado 94
101213	Vetus	● Amarillo	101234	Honda	● Gris Metalizado
101214	Onan	● Marfil	101235	Mariner	● Gris Claro
101215	Nanni	● Azul Metalizado	101236	Tohatsu	● Gris
101218	Aifo int	● Azul	101237	Tohatsu	● Azul Cobalto
101219	B.M.W	● Plata	101238	-	● Negro Mate
101220	Depósito	● Rojo	101249	Solè	Azul
101221	Evinrude	● Azul 69-82	101250	Jonhson	● Blanco 81-83
101222	GM Alpine	● Verde	101252	Mercury	● Negro
101223	Jonhson	● Gris	101253	Mariner	● Gris Metalizado
101224	Jonhson	● Platinum 84	101254	Yamaha	● Azul Metalizado 84
101225	Jonhson 71-80	● Blanco	101255	Suzuki	● Gris 89
-	Evinrude 77-80	-	101256	Volvo Int	● Verde
101226	Selva	● Azul	101257	Aifo Int	● Rojo
101227	Selva	● Azul Metalizado	101258	Volvo Aq	● Gris 89
101228	Suzuki	● Gris	101259	Evinrude	● Azul Xp
101229	Volvo Aq	● Aquamatic	101260	Suzuki	● Negro Metalizado 98
101261	Caterpillar	● Blanco	101308	Iveco	● Blanco
101241	Parsum	● Negro	101248	Jonhson	● Plata

Antifoulings

Pintura Antivegetativa Velox Plus

Pintura antivegetativa para **Hélices, Colas, Ejes, Arbotantes, y todas las partes Metálicas sumergidas.**

Gran adhesión sobre metal desnudo o sobre pinturas originales.

Óptimo poder antivegetativo. No contiene cobre ni otras sustancias que puedan crear corrientes galvánicas.

Óptima capacidad de nivelación ya que no produce espesores que puedan variar el rendimiento hidrodinámico de las partes sobre las que se aplica.

Aplicación: Desengrasar el material disolvente y aplicar papel de lija grano 80-100.

Una hélice nueva debe desengrasarse y lijarse a fondo. Aplicar dos manos a intervalos de 8h.

En las partes sometidas a corrientes galvánicas es aconsejable dar una manos de METAL PRIMER 8h. antes.



Referencia	Descripción	Referencia	Descripción
108100	Velox 0,25lts blanco	108106	Velox 0,25lts gris
108101	Velox 0,50lts blanco	108107	Velox 0,50lts gris
108049	Velox 2,5lts blanco	108051	Velox 2,5lts gris
108103	Velox 0,25lts negro	108121	Velox 0,25lts naranja
108104	Velox 0,50lts negro	108122	Velox 0,50lts naranja
108053	Velox 2,5lts negro		

Velox Metal Primer

Imprimación para la pintura antivegetativa Velox Plus. Para metales especialmente diseñada para utilizarla antes del Velox Plus.

Aplicación en bronce, acero, aluminio, pero también sobre barnices de fábrica de pies de popa o sobre ciclos protectores epóxicos. Se aplica una sola mano. Aplicación en brocha o pistola. Color verde.



Referencia	Descripción	Referencia	Descripción
108109	Velox Metal Primer 0,25lts	108110	Velox Metal Primer 0,50lts
108111	Velox Metal Primer 2,5lts		

Productos Epóxicos

Diluyente nr. 2

108175 0,5Lts 108151 1Lt 108179 2,5Lts

Para antiincrustantes: Marlin TF, Super 505, Marlin Hard, Marlin CF, Maxima, 303, Tritón y universal primer.

Diluyente nr. 4

108182 0,5Lts 108118 1Lts 108183 5Lts

Para esmaltes de poliuretano. Esmaltes y barnices Evergloss, esmalte y antiincrustante Flexy, Velox Plux, Metal Primer y Primer Fibra.



MANTENIMIENTO MOTOR

- Diésel Plus
- Evita con componente Antifouling la formación de bacterias y lodo biológico y por lo tanto la obstrucción de tuberías, filtros e inyectores.
- Hasta 4% menos consumo de combustible y aumento de la potencia (aumento de índice de cetano).
- El motor funciona más suave y silencioso.
- Reduce el desgaste a través del engrase adicional; muy efectivo.
- Proporción de la mezcla: 1:1.000



02073900

Botella 500ml. Para 500lts.

0207391934

Botella 1l. Para 1.000lts.

0207391532

1 bidón 2,5lts. Para 2.500lts.

0207390788

1 bidón 5lts. Para 5.000lts.

0207391017

1 bidón 10lts. Para 10.000lts.

ABSORBENTE DE AGUA CONDENSADA PARA DIÉSEL + GASOLINA

02212300

- Absorbe hasta el 1% del agua del combustible y proporciona una combustión segura, evita la corrosión y la formación de lodo en los depósitos, las tuberías y los inyectores.
- Evita reparaciones costosas a causas de daños por el agua.
- Evita bacterias en los depósitos de diésel.
- Muy efectivo: proporción de mezcla 1:1.000. Botella 500ml.



CONSERVANTE DURADERO PARA DIÉSEL

02193100

- Conserva el combustible diésel durante el almacenaje.
- Para todas las propiedades de diésel y diésel super.
- Ideal durante el almacenaje o en periodos largos de paro.
- Protege contra la formación de sedimentos, humo y Fouling durante el periodo invernal.
- Estabilización de combustión a largo plazo a través de filtros e inyectores con funcionamiento seguro.
- Proporción de mezcla: 1:1.000. Botella 500ml.



LIMPIADOR PARA EL SISTEMA DIÉSEL

02213000

- Aditivo altamente concentrado para la limpieza de todas las propiedades de diésel y diésel super (DIN 51601); elimina residuos en los inyectores, bombas de inyección y en todo el sistema de combustible.
- Se debería aplicar antes y después del invierno.
- Proporciona un consumo reducido.
- Reduce el "golpeo", protege contra la corrosión.
- Proporción de la mezcla: 1:250. Botella 500ml.



GROTAMAR 82

- Especialmente desarrollado para combustibles diesel modernos como el diesel con bajo contenido de azufre y mezclas biodiesel.
- Formula protectora para retrasar la degradación de los oleos provocados por el envejecimiento.
- Rápido y muy eficaz contra bacterias, hongos y levaduras.
- Excelente protección a largo plazo de los depósitos, tuberías y motores.
- Excelente solubilidad y distribución en todos los tipos de combustible diesel y biodiésel.
- Sin productos corrosivos de combustión.
- Protege de forma eficaz acero, aluminio y otros metales no ferrosos contra la corrosión.
- Dosificación de choque: Añadir 200 ml. De grotamar por cada 200 lts. de combustible ó 1 lt. Por cada 1.000 lts. de combustible.
- Dosificación de prevención: Añadir 200 ml. de Grotamar por cada 800 lts. de combustible ó 1 lt. por cada 4.000 lt. de combustible cuando se rellene el tanque.



0219412030

Botella de 200 m.

02194100

Botella de 1 lt.

021941943

Botella de 10 lt.

GASOLINA PLUS

02214300

- Evita residuos dañinos en el carburador, las válvulas, los inyectores, las bujías y la cámara de combustión.
- Evita sonidos raros y funcionamiento irregular, proporciona pleno rendimiento.
- Protege contra la corrosión y la formación de hielo en el carburador.
- Reduce los contaminantes en el gas de escape.
- Idóneo también para el catalizador y el turbo.
- Proporción de la mezcla: 1:500. botella 500ml



LIMPIADOR PARA EL SISTEMA GASOLINA

02213200

- Aditivo limpiador altamente concentrado para la gasolina normal y super (DIN 51600/51607), limpia las válvulas, el carburador y los inyectores.
- Garantiza un consumo de combustible reducido, una combustión con menos contaminantes y un funcionamiento seguro, protege contra la corrosión.
- Reduce el consumo de combustible y proporciona más potencia del motor.
- Proporción de mezcla 1:1250. Consejo: aplicar antes y después del almacenaje de invierno. botella 500ml.



LIMPIADOR DE LODO DE ACEITE

02212900

- Para motores de diésel y gasolina. Limpia y elimina residuos en el circuito de aceite.
- Idóneo también para motores con catalizador y turbocargador y todo tipo de aceite.
- Aplicar siempre después de periodos largos de paro (invernal) o en caso del uso permanente del motor.
- Proporción de la mezcla: 500ml son suficientes para 10lts de aceite de motor.





LIMPIADOR DE SISTEMA DE REFRIGERACIÓN

02456800

- Limpia los sistemas de refrigeración con uno o dos circuitos y los termocambiadores; elimina todos los residuos de sal, cal y óxido.
- Proporciona una refrigeración y seguridad de funcionamiento óptimo.
- Compatible con todos los materiales.
- Proporción de la mezcla: 2 lts son suficientes para sistemas de refrigeración hasta 60lts. (100ml para 3,5lts)



DIÉSEL ANTI FROTZ

02172400

- Prepara el diésel de verano e invierno para temperaturas hasta -30°C y aumenta la capacidad de flujo y filtración del combustible.
- Idóneo para todos los diésel y turbodiésel.
- Proporción de la mezcla: 1:1.000. botella 500ml.



EVITA LAS PÉRDIDAS DE ACEITE

02172300

- Devuelve a las juntas su elasticidad.
- Para todos los motores de gasolina y diésel.
- Reduce el consumo de aceite.
- Protege la sentina contra los daños del medio ambiente y contra la suciedad.
- Proporción de la mezcla: 500ml son suficientes para 7,5lts. de aceite. botella 500ml.



EVALUADOR DE ANTICONGELANTE

02211700

- Comprueba la resistencia al frío del agua refrigerante y de otros sistemas de agua.
- El evaluador de anticongelante de Yachticon es idóneo para etilenglicol y también para propilenglicol Aqua Forzt). 1 und.



CONSERVAR EL MOTOR + EL CARBURADOR

02214400

- Protege los motores y carburadores desde el exterior contra las influencias dañinas del medio ambiente, humedad y corrosión durante el invernaje o la inmovilización. Idóneo para todo tipo de materiales. Bote 400ml.



CONSERVAR EL INTERIOR DEL MOTOR

02456900

- Para la conservación del interior de motores de 2 y 4 cilindros durante la inmovilización temporal o de larga duración.
- Mantiene los émbolos, juntas y cilindros libres de óxido y corrosión.
- Protege contra la radiación UV, sal y otras influencias dañinas del medio ambiente. bote 400ml.



ARRANQUE RÁPIDO

02170300

- Ayuda de arranque con cualquier tipo de temperatura.
- Idóneo para todos los motores de gasolina y diésel.



LIMPIADOR EN FRÍO PARA EL MOTOR

02213300

- Limpia manchas de aceite y grasa en superficies de metal o plástico, especialmente para motores fueraborda, alojamiento de motores o cámaras de máquinas.
- Idóneo también para la limpieza de los cabestrantes y de la dirección. Idóneo para todo tipo de materiales.



LUBRICANTE TK-1

101265

Penetra y disuelve el óxido permitiendo el desmontaje de las partes mecánicas y tornillería.

Expele la humedad y protege la oxidación de las partes eléctricas facilitando los contactos. No ataca las materias plásticas y barnices. No contiene silicona. Envase de 400ml.

LUBRICANTE TK-2

101267

Reduce el mantenimiento, su acción de protección se mantiene durante 1 año. Protege los motores y los equipos mecánicos que trabajan en ambientes marinos o corrosivos. No ataca la goma, las pinturas y las materias plásticas. Envase de 400 ml.

LUBRICANTE TK-3

101268

Lubricante especial con altas prestaciones, que se prestan de manera especialmente óptima al mantenimiento y protección de partes mecánicas en movimiento continuo, operando en condiciones ambientales difíciles. Lubrica en seco, creando un film protector de elevada durabilidad y resistencia a la acción mecánica que preserva las partes tratadas de la corrosión. Ideal para el ambiente marino, gracias a su total adhesividad e hidrorrepelencia. Envase de 40ml.



GRASA

Grasa blanca a base de zinc. Gracias a su fuerte adhesividad y a la gran cantidad de zinc. Contenido en esta grasa en **muy conveniente para proteger, engrasar y evitar el bloqueo de bulones, bornes de Baterías, cierres y equipos que trabajan en ambientes corrosivos** y sometidos a la acción deslavante del agua.

101272

Envase tubo de 250ml.

101273

Envase bidón de 5lts.



GRASA

Grasa Premium Marine formulada específicamente para aplicaciones marinas.

189200

Fórmula Premium de litio para óptima protección a la corrosión en aplicaciones en agua dulce y salada. Ideal para cojinetes de remolques, cardanes y pivotes de colas. Tubo de 283,5gr.



GRASA

MER8M0121966

La grasa marina Quicksilver 2-4-C con teflón es una grasa NLGI 2 de alta calidad, extremadamente versátil, con base de litio, que no se descompone al mezclarse con agua.

- Una excelente resistencia a la oxidación y la degradación
- Aditivos para presión extrema que soportan la fricción en una amplia variedad de operaciones y temperaturas.

Puede aplicarse a los siguientes componentes marinos:

- Sistemas de dirección y articulaciones de cables
- Cables y articulaciones del acelerador y cambios
- Controles remotos
- Ejes de hélice
- Pasadores giratorios
- Mecanismos de bloqueo de la inclinación y tubos de inclinación
- Pasadores de bisagra
- Cojinetes de rueda para remolque de barco



ACEITE ENGRANAJES

Aceite de altísima calidad muy apto para el engrase de las cajas de transmisión de fuerabordas y colas intra/fuerabordas.

Contiene aditivos antioxidantes para guardar invariadas las características del aceite en los periodos de inactividad. Aditivo antidesgaste y presión extrema para reducir el desgaste de las partes metálicas en contacto. Supera las especificaciones OMC 1632.

101275

Envase tubo de 250ml.



02456900

1895503



ACEITE INVERNAJE

Protege las partes internas del motor de la oxidación y de la corrosión. Especialmente diseñado para la protección estacional de los motores intraborda y fueraborda. Ideal para motores de 2 y 4 tiempos. Proporciona una protección química con una película sobre la superficie sin dejar residuos grasos.

02456900

Yachticon Envase de 340gr.

1895503

Envase 3,8lts



ACEITE MOTOR 2 TIEMPOS

Aceite "Blue" Premium **TC-W3** lubricante de altas prestaciones. Ideal para sistemas de inyección o pre-mezcla, óptimo quemado para la combustión sin humos. Deslizante más rápido, combustión más limpia. Reduce significativamente la toxicidad en el mar, comparado con otros aceites fueraborda del mercado. Máxima lubricación. Reduce la fricción de aros, la formación de depósitos de carbónilla y bloqueo de válvulas de escape. Ideal para fuerabordas actuales de altas potencias que necesitan las máximas prestaciones.

Sintético para motores BRP E-Tech / Universal.

- 189502**
Envase de 946 ml.
- 189503**
Envase de 3,78 lts.
- 1895402**
Sintético. Envase de 946 ml.
- 1895403**
Sintético. Envase de 3,78 lts.



ACEITE MOTOR INTRABORDA 4 TIEMPOS

Aceite **25W-40** para motores Intraborda 4 tiempos. Formulatio para dar una excelente lubricación y protección contra la corrosión. Este producto está desarrollado para el ambiente marino y es el adecuado para motores de 4 tiempos standard. Los beneficios para su motor son una reducción del desgaste de sus componentes internos, protección frente la corrosión, pistones más limpios. Baja temperatura de operación. Recomendado para motores mercruiser, OMC y Volvo Penta.

Cumple las normativas API SJ, CF-2, CH4.

- 189402**
Envase de 946 ml. Mercruiser 92-802837Q1
- 189404**
Envase de 4,7 lts. Mercruiser 92-857389-A1
- 1894402**
Sintético. Envase de 946 ml. Mercruiser 92-883724K01
- 1894404**
Sintético. Envase de 4,7 lts. Mercruiser 92-883725K01



ACEITE MOTOR FUERABORDA 4 TIEMPOS

Aceite **10W-30** para motores fueraborda de 4 tiempos. Formulado con una base Premium y con aditivos altamente refinados. Especialmente formulado para los motores marinos de 4 tiempos Mercury, Yamaha, Johnson-Evinrude, Suzuki y Honda. Reduce la fricción. Protección máxima frente la corrosión. La baja temperatura del fluido ofrece mejor arranque en frío. Mantiene el motor limpio y mejora su eficiencia.

Cumple las normativas API SJ, CF-2, CH4.

- 189422**
Envase de 946 ml. Mercury 92-802833Q1
- 189423**
Envase de 3,78 lts. Mercury 92-802835Q1
- 1896902**
Envase de 946 ml. Sintético.
- 1896903**
Envase de 3,78 lts. Sintético.
- 1895536**
Envase de 61 lts.



ACEITE DE MOTOR DIÉSEL 15W-40

Primer aceite diésel ofrecido por Sierra. Con las siguientes especificaciones de fabricación: Volvo VDS-3; Cummins CES200078, CES20077, CES200776; Detroit Diésel DDC93D124; Cat ECF-2, ECF-1; Global DHD-1. Mayor cantidad de detergente para combatir hollín y depósitos de carbón. Certificada por APC CL-4 + Rating.

Se ajusta a las normas más exigentes de gasóleo en la industria marítima.

- 1895532** 1 LTS.
- 1895533** 3,8 LTS.
- 1895535** 18,9 LTS.
- 1895536** 61 LTS.
- 1895537** 208 LTS.

LUBRICANTE POWER TRIM&TILT

189750
Formulado para operar a altas Presiones. Aditivos antiespuma aseguran un fluido uniforme. Diseñado para aplicaciones sujetas a cambios de temperatura.



ACEITE 25W-40

Semi-sintético para motores MERCURY VERADO.

- 1895528**
Envase de 1 lts.
- 1895523**
Envase de 4 lts. Mercury 92-858084 K01.
- 1895526**
Envase de 61 lts.





ACEITE COLAS "PREMIUM" 80W-90

Lubricante Premium para colas recomendado para todas las aplicaciones marinas en general que requieran lubricante clase GL-5. Ideal para reemplazar todas las antiguas aplicaciones de hypoid 90. Formulado para usar en aplicaciones standard, reduce la fricción y protege los engranajes, cojinetes y otros componentes.

Reemplaza: Mercury (Quicksilver). Premium Blend. OMC (system Matched). Hi-Vis lubricant. Yamaha (Yamalube). LUB-GEAR-11-04

189600

Envase de 283,5 gr

189602

Envase de 946 ml.

189605

Envase de 18,95 lts.



ACEITE SINTÉTICO COLAS 80W-90

Lubricante sintético para colas que reduce la fricción incrementado las prestaciones y protegiendo los engranajes, cojinetes y otros componentes. Recomendado para uso en condiciones de operación de altas prestaciones, en colas de fueraborda e intrabordas.

Reemplaza: Mercury (Quicksilver). OMC (system Matched). Hi-Performance Blend. Hi-Vis lubricant. Yamaha (Yamalube). LUB-GEAR-11-04

189650

Envase de 283,5 gr

189652

Envase de 946 ml.

189655

Envase de 18,95 lts.



ACEITE 25W-40

Sintético para motores fueraborda.

189443

Envase de 4 lts. Mercury 92-883723K01.

189448

Envase de 946 ml. Mercury 92-883722K01.

1895512



ACEITE 10W-40

Semi-sintético para motores SUZUKI.

1895512

Envase de 946 ml. Suzuki 990C0-10W40-1 QT.

1895513

Envase de 3,78 lts. Suzuki 990C0-10W40-1 GL.

1895516

Envase de 61 lts.

1895517

Envase de 208 lts.

1894104



ACEITE SAE 30

Sintético para motores intraborda diesel y gasolina.

1894102

Envase de 946 ml. Volvo 3842343.

1894104

Envase de 4,7 lts. Volvo 3842344.

1896802



ACEITE DE ENGRANAJES

Sintético formulado para reducir el desgaste.

1896802

Envase de 946 ml. Volvo 1141679

1896805

Envase de 19 lts. Volvo 114681.

BOMBA DE ACEITE

189788

Bomba para utilizar en fuerabordas e intrafuerabordas. Diseñado para utilizar en envases Ref. 189605 y Ref. 189655 y Bidones.



BOMBA DE ACEITE

189781

Bomba de aceite. Incluye terminales de aceite con línea de llenado flexible. Adaptable para utilizar en envases Ref. 189600 y Ref. 189652.



Motores Fueraborda



- **Ligeros y compactos.** Facilidad de transporte. Sus asas y diseño permiten un transporte sencillo y ligero.
- **Potentes.** Su diseño asegura un alto rendimiento ideal para auxiliares, canoas y veleros.
- Alta resistencia a la corrosión.
- Sistema de encendido digital TCI que asegura un rápido y eficiente encendido.
- Indicador de nivel de aceite lateral de rápida lectura.
- El motor de 2,5 HP dispone únicamente de un depósito interno mientras que los modelos de 4 HP y 5 HP pueden combinar el uso del depósito interno con el externo.



	2,5 HP	4 HP	5 HP
	290000 - Eje Corto	290001 - Eje Corto	290002 - Eje Corto 290011 - Eje Largo
Potencia máxima (Kw):	1.8	2.9	3.6
Acelerador al máximo rango de funcionamiento (rpm):	5.250-5.750	4.500-5.500	4.500-5.500
Tiempos:	4	4	4
Cilindros:	1	1	1
Desplazamiento (cm3):	72	112	112
Diámetro x Carrera:	54x31,5	59x41	59x41
Largo x ancho x altura:	Eje C: 623x345x1021 Eje L:	717x361x1029	717x361x1029 717x361x1156
Peso (Kg):	17	22	C: 22 - L: 24
Ratio engranajes:	27:13(2.08)	27:13(2.08)	27:13(2.08)
Posición engranajes:	N-A	A-N-R	A-N-R
Sistema encendido:	TCI	TCI	TCI
Sistema refrigeración:	Por agua	Por agua	Por agua
Sistema arranque:	Manual	Manual	Manual
Sistema control:	Caña de dirección	Caña de dirección	Caña de dirección
Capacidad depósito interno (L):	0.9	1.1	1.2

Motores Fueraborda



- Ligeros, compactos y silenciosos.
- Sistema de encendido digital CDI que asegura un rápido y eficiente encendido.
- Alta resistencia a la corrosión.
- Conducción suave y precisa.



	9,9 HP	15 HP
	290004 - Eje Corto 290008 - Eje Largo 290007 - Eje Corto-Arranque Eléctrico y Control remoto 290012 - Eje Largo-Arranque Eléctrico y Control remoto	290005 - Eje Corto 290010 - Eje Largo 290009 - Eje Corto con Arranque Eléctrico y Control remoto 290017 - Eje Largo con Arranque Eléctrico y Control remoto
Potencia máxima (Kw):	7.2	11
Acelerador al máximo rango de funcionamiento (rpm):	4.500-5.500	4.500-5.500
Tiempos:	4	4
Cilindros:	2	2
Desplazamiento (cm3):	212	323
Diámetro x Carrera:	56x43	59x59
Largo x ancho x altura:	Eje C: 1038x360x1017 Eje L: 1038x360x1144	1000x427x1080 1000x427x1207
Peso (Kg):	C: 40 - L: 42	C: 55 - L: 57
Ratio engranajes:	27:13(2.08)	27:13(2.08)
Posición engranajes:	A-N-R	A-N-R
Sistema encendido:	CDI	CDI
Sistema refrigeración:	Por agua	Por agua
Sistema arranque:	Manual	Manual
Sistema control:	Caña de dirección	Caña de dirección
Capacidad depósito (L):	12 / opcional: 24	12 / opcional: 24

Motores Fueraborda

FUERABORDA
MOTORES

- El sistema de inyección de combustible (EFI) proporciona un rápido y eficiente arranque.
- Silenciosos gracias al sistema de escape a través de la hélice.
- Dispone de alertas por exceso de temperatura, bajo nivel de aceite y otros indicadores.
- Bajo consumo gracias a la inyección del combustible multipunto que proporciona el sistema EFI.
- Trim y mando a distancia incorporado.



	20 HP EFI	25 HP	40 HP EFI
	290022 - Eje Corto con arranque eléctrico y control remoto. 290018 - Eje Largo con arranque eléctrico y control remoto. 290024 - EFI Eje Largo con arranque manual.	290013 - Eje Corto 290014 - Eje Largo	290020 - Eje Largo con Arranque Eléctrico y Control remoto
Potencia maxima (Kw)	14.7	18.4	29.4
Acelerador al maximo rango de funcionamiento (rpm)	4.500 - 5.500	5.000-6.000	5.000-6.000
Tiempos	4	4	4
Cilindros	2	2	3
Tipo	4 válvulas		6 valvulas
Entrega combustible	Inyección electrónica	Carburador	Inyección electrónica
Desplazamiento (cc)	323	498	747
Potencia y velocidad	14.7Kw@5.000 rpm		29.4Kw@5.500 rpm
Diametro x carrera	59x59	65x75	65x75
Largo x ancho x altura: (mm):	Eje C: 1.000x427x1.080 Eje L: 1.000x427x1.207	724x398x1.154 724x398x1.281	
Ratio engranajes	27:13	27:13(2.08)	26:13
Posicion engranajes	A-N-R	A-N-R	A-N-R
Sistema encendido	ECM	CDI	ECM
Sistema refrigeración	Por agua	Por agua	Por agua
Sistema arranque	Manual / Eléctrico	Manual / Eléctrico	Electrico
Sistema control	Caña de dirección	Caña de dirección / Remoto	Remoto
Sensor alarma presión aceite	Standard		Standard
Sensor alarma temperatura	Standard		Standard
Peso (kg)	C: 55 / L: 57	290013: 78 290014: 80	113

Motores Fueraborda



- El sistema de inyección de combustible (EFI) proporciona un rápido y eficiente arranque.
- Silenciosos gracias al sistema de escape a través de la hélice.
- Dispone de alertas por exceso de temperatura, bajo nivel de aceite y otros indicadores.
- Bajo consumo gracias a la inyección del combustible multipunto que proporciona el sistema EFI.
- Trim y mando a distancia incorporado.



	50 HP EFI	60 HP EFI
	290019 - Eje Largo con Arranque Eléctrico y Control remoto	290021 - Eje Largo con Arranque Eléctrico y Control remoto
Potencia maxima (Kw)	36.8	44.1
Acelerador al maximo rango de funcionamiento (rpm)	5.000-6.000	5.000-6.000
Tiempos	4	4
Cilindros	4	4
Tipo	8 valvulas	8 valvulas
Entrega combustible	Inyeccion electrónica	Inyeccion electrónica
Desplazamiento (cc)	996	996
Potencia y velocidad	36.8Kw@5.500 rpm	44.1Kw@5.500 rpm
Diametro x carrera	65x75	65x75
Ratio engranajes	26:13	26:13
Posicion engranajes	A-N-R	A-N-R
Sistema encendido	ECM	ECM
Sistema refrigeración	Por agua	Por agua
Sistema arranque	Electrico	Electrico
Sistema control	Remoto	Remoto
Sensor alarma presión aceite	Standard	Standard
Sensor alarma temperatura	Standard	Standard
Peso (kg)	119	119

MERCURY FUERABORDA

HP	CIL	DESDE	AÑO	HP	CIL	DESDE	AÑO	HP	CIL	DESDE	AÑO
2.2	1	8075603	1984	8	2	C221500	1990	35	2	1755799	1965
2.2	1	8087123	1985	9.8	2	5206550	1979	35	2	1960827	1966
2.2	1	A800761	1986	9.8	2	5541280	1980-81	35	2	2097800	1967
2.2	1	A805221	1987	9.8	2	5965263	1982	35	2	2300972	1968
2.2	1	A817421	1988	9.8	2	6263906	1983	35	2	2487558	1969
2.2	1	A837101	1989	9.8	2	6438338	1984	35	2	6445653	1984
3	1	A855097	1990	9.8	2	6620196	1985	35	2	6626696	1985
3.4 L	6	6436883	1984	9.8 (100)	2	1397581	1961	35	2	A922171	1986
3.4 L	6	A129445	1985	9.8 (110)	2	1455240	1962	35	2	B110789	1987
3.4 L	6	A912426	1986	9.8 (110)	2	1474328	1963	35	2	B238644	1988
3.5	1	6202173	1983	9.8 (110)	2	1607083	1964	35	2	B393190	1989
3.5	1	6434771	1984	9.8 (110)	2	1742746	1965	35 (300)	4	1271885	1960
3.5	1	6594744	1985	9.8 (110)	2	1865779	1966	40	2	2874704	1970
3.6	1	5404657	1980-81	9.8 (110)	2	2098352	1967	40	2	3043031	1971
3.6	1	5910968	1982	9.8 (110)	2	2290663	1968	40	2	3219678	1972
3.9	1	1655013	1964	9.8 (110)	2	2508759	1969	40	2	3474578	1973
3.9	1	1738941	1965	9.8 (110)	2	2798057	1970	40	2	3859435	1974
3.9	1	1865633	1966	9.8 (110)	2	3002814	1971	40	2	4118385	1975
3.9	1	2098037	1967	9.8 (110)	2	3263263	1972	40	2	4362215	1976
3.9	1	2278851	1968	9.8 (110)	2	3482753	1973	40	2	4564002	1977
4	1	2498136	1969	9.8 (110)	2	3795658	1974	40	2	4860103	1978
4	1	2771662	1970	9.8 (110)	2	4079675	1975	40	2	5174089	1979
4	1	3028361	1971	9.8 (110)	2	4304785	1976	40	2	5556230	1980-81
4	1	3296137	1972	9.8 (110)	2	4605112	1977	40	2	5991215	1982
4	1	3529446	1973	9.8 (110)	2	4839254	1978	40	2	6228285	1983
4	1	3764825	1974	9.9	2	A918999	1986	40	4	C159200	1989
4	2	5589202	1980-81	9.9	2	B114231	1987	40	4	C221500	1990
4	2	9075839	1976	9.9	2	B233200	1988	40 350	2	1356948	1961
4	2	9172806	1978	9.9	2	B385500	1989	45	4	1476510	1962
4	1	A818721	1988	9.9	2	C221500	1990	45	4	A914859	1986
4	1	A837101	1989	10	2	1290910	1960	45	4	B110789	1987
4	1	A855097	1990	15	2	1288910	1960	45	4	B238644	1988
4	1	A906702	1986	15	2	1346448	1961	45	4	B393190	1989
4	1	B114109	1987	15	2	B293117	1988	45 (400)	4	1279685	1960
4.5	1	4108120	1975	15	2	B385500	1989	45 (400)	4	1384806	1961
4.5	1	4377557	1976	15	2	C221500	1990	50	4	1421113	1961
4.5	1	4597262	1977	18	2	5860332	1980-81	50	4	1477910	1962
4.5	1	4869518	1978	18	2	5954911	1982	50	4	1552535	1963
4.5	1	5270784	1979	18	2	6171607	1983	50	4	1605952	1964
4.5	1	5595532	1980-81	18	2	6443973	1984	50	4	1755549	1965
4.5	1	6025119	1982	18	2	6617631	1985	50	4	1870389	1966
4.5	1	6232381	1983	20	2	1558310	1963	50	4	2097445	1967
4.5	1	6428076	1984	20	2	1606903	1964	50	4	2305101	1968
4.5	1	6608536	1985	20	2	1755849	1965	50	4	2514919	1969
5	1	A819951	1988	20	2	1866496	1966	50	4	2736807	1970
5	1	A837101	1989	20	2	1997990	1967	50	4	3009934	1971
5	1	A855097	1990	20	2	2296267	1968	50	4	3235063	1972
6	2	1408611	1961	20	2	2550065	1969	50	4	3478003	1973
6	2	1485612	1962	20	2	2827677	1970	50	4	3816308	1974
6	2	1551443	1963	20	2	2991679	1971	50	4	4141450	1975
6	2	1607513	1964	20	2	3226958	1972	50	4	4357650	1976
6	2	1745521	1965	20	2	3537531	1973	50	4	4576237	1977
6	2	1958278	1966	20	2	3755885	1974	50	4	4962056	1978
6	2	2096171	1967	20	2	4103290	1975	50	4	5193259	1979
6	2	2284857	1968	20	2	4293920	1976	50	4	5531630	1980-81
6	2	A910596	1986	20	2	4580036	1977	50	4	5949386	1982
6	2	B114231	1987	20	2	4819249	1978	50	4	6275323	1983
6	2	B233200	1988	20	2	5183393	1979	50	4	6448808	1984
6	2	B385500	1989	20	2	5606492	1980-81	50	4	6586624	1985
7.5	2	2529895	1969	20	2	A910971	1986	50	3	A912478	1986
7.5	2	2810637	1970	20	2	B114231	1987	50	3	B110789	1987
7.5	2	3016581	1971	20	2	B238464	1988	50	3	B239242	1988
7.5	2	3274633	1972	20	2	B385500	1989	50	3	B396036	1989
7.5	2	3488153	1973	20	2	C221500	1990	50	3	C221500	1990
7.5	2	3801458	1974	22 (200)	2	1292910	1960	60	3	1303411	1960
7.5	2	4087015	1975	22 (200)	2	1339948	1961	60	3	6428681	1984
7.5	2	4314385	1976	25	2	1467499	1962	60	3	6609651	1985
7.5	2	4691222	1977	25	2	5705532	1980-81	60	3	A197392	1986
7.5	2	4851693	1978	25	2	5942041	1982	60	3	B110789	1987
7.5	2	5226935	1979	25	2	6185159	1983	60	3	B239242	1988
7.5	2	5524660	1980-81	25	2	6453343	1984	60	3	B396036	1989
7.5	2	5936301	1982	25	2	6593849	1985	60	3	C221500	1990
7.5	2	6239857	1983	25	2	A911346	1986	65	4	1542745	1963
7.5	2	6430041	1984	25	2	B114231	1987	65	4	1606282	1964
7.5	2	6611886	1985	25	2	B238464	1988	65	4	1765044	1965
8	2	A197112	1986	25	2	B385500	1989	65	4	1869564	1966
8	2	B114231	1987	25	2	C221500	1990	65	4	2119749	1967
8	2	B233200	1988	35	4	1570507	1963	65	4	2309311	1968
8	2	B385500	1989	35	2	1628795	1964	65	4	2503991	1969

MERCURY FUERABORDA

HP	CIL	DESDE	AÑO	HP	CIL	DESDE	AÑO	HP	CIL	DESDE	AÑO
65	4	2803562	1970	90	3	B110054	1987	150	6	3752620	1974
65	4	2997339	1971	90	3	B240451	1988	150	6	4125985	1975
65	3	3293184	1972	90	3	C100000	1989	150XS	6	4319880	1976
65	3	3547987	1973	90	3	C221500	1990	150XS	6	4602012	1977
65	3	3807833	1974	90cc	2	A907702	1986	150XS	6	4868648	1978
65	3	4136685	1975	90cc	2	B114221	1987	V-150	6	4868998	1978
65	3	4382057	1976	95	6	1869776	1966	V-150	6	5129480	1979
70	3	1296411	1960	95	6	2097280	1967	V-150	6	5503247	1980-81
70	3	1413611	1961	100	6	1503332	1962	V-150	6	5944791	1982
70	3	1503459	1962	100	6	1518384	1963	V-150	6	6220254	1983
70	3	4382057	1976	100	6	1665002	1964	V-150	6	6443213	1984
70	3	4571652	1977	100	6	1755459	1965	V-150	6	6616991	1985
70	3	4825249	1978	100	6	2318586	1968	V-150	6	A904646	1986
70	3	5128280	1979	100	6	2484633	1969	V-150	6	B116662	1987
70	3	5579017	1980-81	100	4	B209468	1988	V-150	6	B242881	1988
70	3	5974683	1982	100	4	C100000	1989	V-150	6	C100861	1989
70	3	6279960	1983	100	4	C221500	1990	V-150	6	C221500	1990
70	3	B110054	1987	102cc	2	A819211	1988	V-150XR2	6	A905191	1986
70	3	B240451	1988	102cc	2	A837101	1989	V-150XR2	6	B289430	1988
70	3	C100000	1989	110	6	1870204	1966	V-150XR4	6	B242885	1988
75	4	6432901	1984	110	6	2097385	1967	V-175	6	4301235	1976
75	4	6613221	1985	115	6	2836019	1970	V-175	6	4563802	1977
75	4	A197882	1986	115	6	3023086	1971	V-175	6	4838074	1978
75	3	C100000	1989	115	6	3270480	1972	V-175	6	5180109	1979
75	3	C221500	1990	115	6	3525441	1973	V-175	6	5488752	1980-81
80	4	1335465	1960	115	6	3761035	1974	V-175	6	6618751	1985
80	4	1398630	1961	115	6	4112635	1975	V-175	6	A918329	1986
80	4	2559001	1969	115	6	4310785	1976	V-175	6	B116662	1987
80	4	2783253	1970	115	6	4567952	1977	V-175	6	B241881	1988
80	4	2986444	1971	115	6	4855153	1978	V-175	6	C100861	1989
80	4	3186263	1972	115	6	5168574	1979	V-175	6	C221500	1990
80	4	4831999	1978	115	6	5600967	1980-81	V-200	6	4839034	1978
80	4	5141097	1979	115	6	6006834	1982	V-200	6	5158929	1979
80	4	5582562	1980-81	115	6	6262961	1983	V-200	6	5464486	1980-81
80	4	5987161	1982	115	6	6440183	1984	V-200	6	6073192	1982
80	4	6232941	1983	115	6	6630171	1985	V-200	6	6203991	1983
80	3	A966142	1987	115	6	A907777	1986	V-200	6	6435503	1984
80	3	B240451	1988	115	6	B117567	1987	V-200	6	6625221	1985
80	3	C100000	1989	115	6	B239242	1988	V-200	6	A913228	1986
85	6	1460999	1963	115	4	C100000	1989	V-200	6	B116662	1987
85	6	1648888	1964	115	4	C221500	1990	V-200	6	B241881	1988
85	4	3493913	1973	125	6	2314956	1968	V-200	6	C100861	1989
85	4	3865695	1974	125	6	2536210	1969	V-200	6	C221500	1990
85	4	4092965	1975	135	6	2839369	1970	210cc	2	A918999	1986
85	4	4590512	1977	135	6	3036066	1971	210cc	2	B114231	1987
85XS	4	4366802	1976	V-135	6	A909997	1986	210cc	2	B233405	1988
90	6	1755444	1965	V-135	6	B116662	1987	210cc	2	B385500	1989
90	6	4854301	1978	V-135	6	B241881	1988	V-220	6	B241881	1988
90	6	5160324	1979	V-135	6	C100861	1989	V-225	6	5615282	1980-81
90	6	5594657	1980-81	V-135	6	C221500	1990	V-250	6	C139860	1989
90	6	5996390	1982	140	6	3293234	1972	V-250	6	C221500	1990
90	6	6246856	1983	140	6	4865678	1978	V-275	6	C139860	1989
90	6	6436123	1984	140	6	5189788	1979	V-275	6	C221500	1990
90	6	6623151	1985	140	6	5625108	1980-81	V-300	6	5611648	1980-81
90	6	A902436	1986	150	6	3502806	1973	V-300	6	6239853	1983



**18-5007
KIT ENCENDIDO**

— CONTIENE —

Ref #	O.E. #	Descripción
18-5153	398-174	Juego de contacto
18-5206	398-693	Condensador



**18-5012
KIT ENCENDIDO**

— CONTIENE —

Ref #	O.E. #	Descripción
18-5148	394-1100A3	Juego de contacto
18-5169	394-1130A1	Condensador



**18-5139
JUEGO DE CONTACTOS**

Reemplaza: 336-4318A2, 336-4318A4, 336-4318A3,
336-3948A3, 336-3948A2
(2) 18-5139 = (1) 336-4318A2



18-5140
JUEGO CONTACTOS
Reemplaza: 398-2202



18-5148
JUEGO DE CONTACTOS
Reemplaza: 394-1100A3, 394-1100A2, 394-352A1



18-5153
JUEGO DE CONTACTOS
Reemplaza: 398-174



18-5169
CONDENSADOR
Reemplaza: 394-1130A1, 394-1130, 397-741, 397-359



18-5206
CONDENSADOR
Reemplaza: 398-693



18-5207
CONDENSADOR
Reemplaza: 398-713



18-5187
BOBINA ENCENDIDO
Reemplaza: 339-856991A1, 339-850227
Para: Mariner 200DFI, 225DFI, V135DFI (2.5L), V150DFI (2.5L) y Mercury 3.0DFI



18-5180
BOBINA ENCENDIDO
Reemplaza: 392-825101T, 392-825101
Para: 40/45/50 4-tiempos



18-5182
BOBINA ENCENDIDO
Reemplaza: 823033
Para: 2.5/3/3.3 HP



18-5185
BOBINA ENCENDIDO
Reemplaza 16064A1, 815113T02
Para: 4/5 HP



18-5178
BOBINA ENCENDIDO
Reemplaza: 398-173, 398-716



18-5181
BOBINA ENCENDIDO
Reemplaza: 802371A1

① 18-5181D
Display Package



18-5186
BOBINA ENCENDIDO
Reemplaza: 339-7370A13, 339-832757A4

① 18-5186D
Display Package



18-5433
BOBINA ENCENDIDO
Reemplaza: 32193A2, 38547, 392-806529A1, 898253T24
(Utiliza una resistencia externa)

Display Package



18-23205
BOBINA ENCENDIDO
Reemplaza: 339-859738T1
Para: Mercury 25 4-Tiempos(G590000-P016999), 40 4-tiempos 4 cil(T178500-T598999), 50 4-tiempos 4 cil(T178500-T598999), 60 4-tiempos 4 cil(T178500-T598999)



18-25400
BOBINA
Reemplaza: 16066004
Para: Mercury 8/9.9 4-tiempos(R042475 & sup)

① Referencias acabadas en D envasadas

**18-25513
BOBINA**

Reemplaza: 803844T01
Para: Mercury 8/9.9 4-tiempos (R042475 & Sup)

**18-5775
CAJA INTERRUPTOR**

Reemplaza: 332-7778A6, 332-7778A9, 332-7778A12, 332-7778A7, 332-7778A3, 332-7778A1, 332-5524A1, F7778A9, F749301

**18-5776
CAJA INTERRUPTOR**

Reemplaza: 339-7452A3, 339-7452A2, 339-7452A1

**18-5777
CAJA INTERRUPTOR**

Reemplaza: 339-7452A15, 339-7452A19, 339-7452A9, 339-7452A7

**18-5778
CAJA INTERRUPTOR**

Reemplaza: 339-7452A14, 339-7452A21, 339-7452A11, 339-7452A8

**18-5786
CONEXIÓN CAJA INTERRUPTOR**

Reemplaza: 332-4911A2
Para: 20 HP

**18-5788
CONEXIÓN CAJA INTERRUPTOR**

Reemplaza: 339-6222A8
Para: 4 HP

**18-5790
CONEXIÓN CAJA INTERRUPTOR**

Reemplaza: 18495A26, 18495A19, 18495A12
Para: 75-90 HP

**18-5791
CONEXIÓN CAJA INTERRUPTOR**

Reemplaza: 19052A8, 19052A5, 19052A3
Para: 50-60 HP

**18-5792
CONEXIÓN CAJA INT.**

Reemplaza: 16061T
Para: 4/5 HP

**18-5793
CONEXIÓN CAJA INTERRUPTOR**

Reemplaza: 823034, 823034T
Para: 2.5/3.3 HP

**18-5881
CAJA INTERRUPTOR**

Reemplaza: 332-5772A7, 332-5772A5, 332-5772A3, 332-5772A2, 332-5772A1, F720301

**18-1151
COJINETE ROTOR**

Reemplaza: 30-20066
SKF Francia R822T

**18-1152
COJINETE ROTOR**

Reemplaza: 30-26379
SKF Francia 6002-2 RSI/HT

HP	MODELO	DESDE N° DE SERIE	HASTA N° SERIE	JUEGO DE CONTACTOS	CONDENSADOR	KIT ENCENDIDO	BOBINA	CAJA ENCENDIDO
2 TIEMPOS								
2.2M		A8075603	& sup.	—	—	—	—	—
2.5		A855097	& sup.	—	—	—	—	—
2.5 CD IGN		A855097	& sup.	—	—	—	18-5182	—
3 CD IGN		A855097	& sup.	—	—	—	18-5182	—
3.3		D901217	& sup.	—	—	—	18-5182	—
3.5	⑤	358136	359615	—	—	—	—	—
3.6		540657	& sup.	—	—	—	—	—
3.9		1655013	2498155	18-5140	18-5212	18-5008	—	—
4		2498136	2693114	18-5140	18-5212	18-5008	—	—
4	⑧	2771622	A809600	18-5139	—	—	—	—
4		A809601	& sup.	—	—	—	—	—
4 (2 cil.prod. de USA)		5589202	& sup.	—	—	—	—	18-5788
4		G710613	& sup.	—	—	—	—	18-5792
4.5		4107220	& sup.	18-5139	—	—	—	—
5	⑤	338136	& sup.	—	—	—	18-5178	—
5	⑦	338136	& sup.	—	—	—	—	—
5 PHELON		574128	786612	—	—	—	18-5185	—
5		A809601	& sup.	—	—	—	—	—
5.9 (Mark 6) (Phelon)		888005	1134535	—	—	—	18-5178	—

① Necesarias 2 unids ② Necesarias 3 unids ③ Necesarias 4 unids ④ Necesarias 6 unids ⑤ Sólo Phelon Magneto ⑥ Sólo arranque manual
 ⑦ Sólo Bendix Scintilla Magneto ⑧ Excepto "Gnat"
 ⑨ Para caja de encendido con conexiones tuerca standard use 18-5776 – Para caja de encendido con conexiones tipo bala use 18-5777
 ⑩ Para caja de encendido con conexiones tuerca standard use 18-5776 – Para caja de encendido con conexiones tipo bala use 18-5778

HP	Modelo	Desde nº de serie	Hasta nº de serie	Juego de contactos	Condensador	Kit Encendido	Bobina	Caja Encendido
6	⑤	1184570	& Sup	—	—	—	18-5178	—
6		1408611	1610264	—	—	—	18-5178	—
6		1610265	2529894	18-5140	18-5212	18-5008	—	—
6		A197112	G760299	—	—	—	18-5186 ①	18-5777
6		G760300	T800749	—	—	—	18-5186	—
7.5	⑤	214324	& Sup	18-5153	18-5207	—	18-5178	—
7.5		2529895	2721150	18-5140	18-5212	18-5008	—	—
7.5		3274633	3801457	18-5139	—	—	—	—
7.5		3801458	& Sup	—	—	—	—	—
8		A197112	G760299	—	—	—	18-5186 ①	18-5777
8		A760300	& Sup	—	—	—	18-5186	18-5777
9.8		1470349	1865778	18-5153	18-5206	18-5007	18-5178	—
9.8		1865776	2708898	18-5140	18-5212	18-5008	—	—
9.8		2798057	3263262	18-5139	—	—	—	—
9.8		3263263	3795657	18-5139	—	—	—	—
9.8		3795658	& Sup	—	—	—	—	—
210CC	Sail Power	A918999	& Sup	—	—	—	18-5186 ①	18-5777
9.9		A197112	G760299	—	—	—	18-5186 ①	18-5777
9.9		G760300	& Sup	—	—	—	18-5186	18-5777
10	PHELON	—	—	—	—	—	18-5178	—
10		1120828	112327	18-5153	18-5206	18-5007	18-5178	—
10		595628	112327	18-5153	18-5206	18-5007	18-5178	—
10		595628	& Sup	18-5153	18-5206	18-5007	18-5178	—
10		D038000	G760299	—	—	—	—	18-5777
10		1200114	1499331	18-5153	18-5206	18-5007	18-5178	—
15		B292414	G760299	—	—	—	18-5186 ①	18-5777
15		G760300	& Sup	—	—	—	18-5186	18-5777
15	SEA PRO	G044027	G437999	—	—	—	18-5186	—
15		G438000	G760299	—	—	—	18-5186	18-5777
15		G760300	& Sup	—	—	—	18-5186	—
15	COMM	G760300	& Sup	—	—	—	18-5186	—
15	NON COM	G760300	& Sup	—	—	—	18-5186	—
15XD	COMM	G760300	& Sup	—	—	—	18-5186	—
15XD	NON COMM	760300	& Sup	—	—	—	18-5186	—
18		5837437	6443972	—	—	—	18-5186 ①	18-5776
18		6443973	& Sup	—	—	—	18-5186 ①	⑧
18 BULLET	CONN	6443973	& Sup	—	—	—	18-5186	—
20		860979	& Sup	18-5153	18-5206	18-5007	18-5178	—
20		1558310	1592567	—	—	—	18-5178	—
20		1592568	2827676	—	—	—	—	—
20		2827677	3226957	18-5139	—	—	—	—
20		3226958	3537530	18-5139	—	—	—	—
20		3537531	3755884	—	—	—	18-5186	18-5786
20		3755884	4403786	—	—	—	—	—
20		4403787	6443972	—	—	—	—	—
20		6443973	G044026	—	—	—	18-5186 ①	18-5777
20		G044027	G437999	—	—	—	18-5186	—
20		G438000	G760299	—	—	—	18-5186 ①	18-5777
20	COMM	G760300	T800999	—	—	—	18-5186	—
20 NON	COMM	G760300	T800999	—	—	—	18-5186	—
20 JET		G044027	G760299	—	—	—	18-5186	—
20 JET		G760300	& Sup	—	—	—	18-5186	—
22		1158546	1499331	18-5153	18-5206	18-5007	18-5178	—
25 KF9		377150	379008	18-5148	18-5169	18-5012	—	—
25 KG9		377150	379008	18-5148	18-5169	18-5012	—	—
25 MARK40		377150	379008	18-5148	18-5169	18-5012	—	—
25		5705532	6443972	—	—	—	18-5186 ①	18-5776
25	NUT	6443973	& Sup	—	—	—	18-5186 ①	⑧
25	BULLET	6443973	& Sup	—	—	—	18-5186	—
25		B238464	G044026	—	—	—	18-5186 ①	18-5777
25		G04027	G437999	—	—	—	18-5186	—
25		G438000	G760299	—	—	—	18-5186	—
25	COMM	G760300	& Sup	—	—	—	18-5186	—
25	NONCOMM	G760300	& Sup	—	—	—	18-5186	—
25		E268781	& Sup	—	—	—	—	—
30	MK 30 55	—	—	—	18-5169	—	—	—
30		1271884	1448139	—	18-5169	—	—	—
30		G053314	G380074	—	—	—	—	—
30		G380075	G589999	—	—	—	—	—
30		G590000	T598999	—	—	—	—	—
30	Jet	C159200	G589999	—	—	—	18-5186 ①	18-5881
30	JET	G590000	T178499	—	—	—	—	—
35	350	1271884	1448139	18-5148	18-5169	18-5012	—	—
35	35A	1271884	1448139	—	18-5169	—	—	—
35		1571114	2874703	18-5140	18-5212	18-5008	—	—
35	NUT	6445653	B110788	—	—	—	18-5186 ①	⑧
35	BULLET	6445653	B110788	—	—	—	18-5186 ①	18-5778
35		B110789	& Sup	—	—	—	18-5186	18-5778
40		831021	1279684	18-5148	18-5169	18-5012	—	—
40		1279685	1476509	—	18-5169	—	—	—
40		3336258	3859434	—	—	—	18-5186	—
40 (2 cil.)		3859435	5823917	—	—	—	18-5186	—
40 (2CIL)		3859435	5823917	—	—	—	—	—
40 (2 cil.)		5823918	6443973	—	—	—	18-5186 ①	18-5776
40 (2CIL)		G053314	G380074	—	—	—	—	—
40 (2CIL)		G380075	G589999	—	—	—	—	—
40 (2CIL)		G590000	& Sup	—	—	—	—	—
40 (3CIL)		G531301	T999999	—	—	—	—	—
40 LIGHT		N000513	& Sup	—	—	—	—	—
40XR	LIGHTING	N000513	& Sup	—	—	—	—	—
40 (4 cil.)		C159200	& Sup	—	—	—	18-5186 ③	18-5881
40	JET	T178500	& Sup	—	—	—	—	—
45		1139538	& Sup	18-5148	18-5169	18-5012	—	—
45		1476510	1531958	—	18-5169	—	—	—
45/50 (4 cil.)		5531630	& Sup	—	—	—	18-5186 ③	18-5881
45 (3CIL)	JET	G290584	G589999	—	—	—	18-5186	—

① Necesarias 2 unids ② Necesarias 3 unids ③ Necesarias 4 unids ④ Necesarias 6 unids ⑤ Sólo Phelon Magneto ⑥ Sólo arranque manual
 ⑦ Sólo Bendix Scintilla Magneto ⑧ Excepto "Gnat" N/A No Aplicable
 ⑨ Para caja de encendido con conexiones tuerca standard use 18-5776 – Para caja de encendido con conexiones tipo bala use 18-5777
 ⑩ Para caja de encendido con conexiones tuerca standard use 18-5776 – Para caja de encendido con conexiones tipo bala use 18-5778

HP	Modelo	Desde nº de serie	Hasta nº de serie	Juego de Contacto	Condensador	Kit Encendido	Bobina	Caja Encendido
45 JET		G760300	T178499	--	--	--	18-5180	--
45 4 TIEMPOS		G231123	T178499	--	--	--	18-5180	--
50		1421113	2305100	--	18-5169	--	--	--
50		1770179	2116317	--	18-5169	--	--	--
50	⑥	2116318	2305100	--	18-5169	--	--	--
50		2305101	2858813	--	--	--	--	--
50 (4CIL)		2858814	4140999	--	--	--	--	--
50 (4CIL)		4141000	4357639	--	--	--	--	--
50 (4CIL)		4357640	5193258	--	--	--	--	--
50 (4CIL)		5193259	5531629	--	--	--	18-5186	18-5881
50 (4CIL)		5531630	& Sup	--	--	--	18-5186	18-5881
50 4-tiempos & Bigfoot		G231123	T178499	--	--	--	18-5180	--
50/60 (3 cil.)		6428681	D000749	--	--	--	18-5186 ②	18-5775
50/55/60 (3 cil.)		D000750	G589999	--	--	--	18-5186 ②	18-5791
50 (3CIL)		G590000	T999999	--	--	--	--	--
55 (3CIL)		D000750	G589999	--	--	--	18-5186	--
55 (3CIL)		G590000	G760299	--	--	--	--	--
55 (3CIL)		G760300	& Sup	--	--	--	--	--
60 MK75		1072997	& Sup	--	--	--	--	--
60 (6CIL)		1303411	1542744	--	--	--	--	--
60 (3CIL)		6428681	D000749	--	--	--	18-5186	18-5775
60 (3CIL)		D000750	G589999	--	--	--	18-5186	--
60 (3CIL)		G590000	G760299	--	--	--	--	--
60 (3CIL)		G760300	& Sup	--	--	--	--	--
65 (4CIL)		1542745	2309310	--	18-5169	--	--	--
65 (4CIL)	650	2309311	2803561	--	--	--	--	--
65 (4CIL)	650E	2309311	2803561	--	--	--	--	--
65 (4CIL)		2803562	2874263	--	--	--	--	--
65 (4CIL)		2997339	3293183	--	--	--	--	--
65 (3CIL)	3 3/8 COIL	3293184	3525440	--	--	--	--	--
65 (3CIL)	2 7/8 COIL	3293184	3525440	--	--	--	--	--
65 (3CIL)		4382057	4571651	--	--	--	--	18-5775
65 (3CIL)		3547987	4382056	--	--	--	--	--
65 JET		G438000	& Sup	--	--	--	--	--
65 jet		D283222	G437999	--	--	--	18-5186	--
70	MK75,78	1110600	& Sup	--	--	--	18-5433	--
70 (6CIL)		1296411	1566239	--	--	--	18-5433	--
Merc 70		4571652	5128279	--	--	--	--	18-5775
Mariner70		5128280	& Sup	--	--	--	18-5186 ②	18-5775
70		1296411	1566239	--	--	--	18-5433 ①	--
70		5579016	6428680	--	--	--	18-5186 ②	18-5775
70/75 (3 cil.)		C272000	D283221	--	--	--	18-5186 ②	18-5775
75 (3 cil.)		D283222	G437999	--	--	--	--	18-5790
75 (4 cil.)		6432901	& Sup	--	--	--	18-5186 ③	18-5881
75 (3CIL)		C222000	D283221	--	--	--	18-5186	18-5775
75 (3CIL)		D283222	G437999	--	--	--	18-5186	--
75 (3CIL)		G438000	& Sup	--	--	--	--	--
75 (3CIL)	OPTIMAX	T801000	& Sup	--	--	--	--	--
80		1335465	1566239	--	--	--	18-5433 ①	--
Mariner 80 (4cil.)		5144547	& Sup	--	--	--	18-5186 ③	--
Merc 80 (4cil.)		5582562	6432900	--	--	--	18-5186 ③	--
80		2559001	3493912	--	--	--	--	--
80 (4 cil.)		4831999	5141096	--	--	--	--	18-5881
80 (4 cil.)		5141097	6432900	--	--	--	18-5186	18-5881
80 (3 cil.)		A996142	& Sup	--	--	--	18-5186 ②	18-5775
80 Jet		D283222	G437999	--	--	--	--	18-5881
80JET		G438000	& Sup	--	--	--	--	--
85 (6cil)		1460999	1766823	--	--	--	18-5433 ①	--
85 (4cil)		3493913	3865694	--	--	--	--	--
85 (4cil)		3865695	4366801	--	--	--	--	--
85 (4 cil.)		4366802	4831998	--	--	--	--	18-5881
90		1766824	1869775	--	--	--	18-5433 ①	--
90		4845301	5299505	--	--	--	--	--
90 (6 cil.)		5299506	& Sup	--	--	--	18-5186 ④	18-5775 ①
90 (3 cil.)		A996142	D283221	--	--	--	18-5186 ②	18-5775
90 (3 cil.)		D283222	G437999	--	--	--	18-5186	18-5790
90 (Powerhead)	Sport Jet	E023150	E095087	--	--	--	18-5775	--
90 (3CIL)		G438000	& Sup	--	--	--	--	--
90 OPTIMAX		T801000	& Sup	--	--	--	--	--
95		1869776	1935100	--	--	--	18-5433 ①	--
95		1935101	2318585	--	--	--	--	--
100 (6 cil.)		1464949	2318585	--	--	--	18-5433 ①	--
100 (6CIL)		2318586	2536018	--	--	--	--	--
100 (6CIL)		2399698	2641854	--	--	--	--	--
100 (6CIL)		2641855	3253111	--	--	--	--	--
100 (4 cil.)		B209468	G437999	--	--	--	18-5186 ③	18-5881
100 (4CIL)		G438000	& Sup	--	--	--	--	--
105 Jet		D082000	G303045	--	--	--	18-5186 ④	18-5775 ①
110		1870204	2314955	--	--	--	18-5433 ①	--
115 (6CIL)		5314656	& Sup	--	--	--	18-5186 ④	18-5775 ①
115 (6CIL)		2836019	2928720	--	--	--	--	--
115 (6CIL)		2928721	4112634	--	--	--	--	--
115 (6CIL)		4112635	5314655	--	--	--	--	--
115 (6CIL)		5314656	& Sup	--	--	--	18-5186	--
115 (4CIL)		B209468	G437999	--	--	--	18-5186 ③	--
115 (4CIL)		G438000	& Sup	--	--	--	--	--
115 (3CIL)	OPTIMAX	T801000	& Sup	--	--	--	--	--
115 (3CIL)	PRO XS	B751825	& Sup	--	--	--	--	--
115 (3CIL)		C100000	G437999	--	--	--	--	18-5881
125 (4CIL)		D283222	G437999	--	--	--	18-5186	18-5881
125 (6CIL)		2314956	2839368	--	--	--	--	--
125 (6CIL)		2400058	2641854	--	--	--	--	--
125 (6CIL)		2641855	3253111	--	--	--	--	--
125 (4CIL)		G438000	& Sup	--	--	--	--	--
125 (3CIL)	OPTIMAX	B736885	& Sup	--	--	--	--	--

① Necesarias 2 unids. ② Necesarias 3 unids ③ Necesarias 4 unids ④ Necesarias 6 unids ⑤ Sólo Phelon Magneto ⑥ Sólo arranque manual
 ⑦ Sólo Bendix Scintilla Magneto
 ⑧ Except "Gnat"
 ⑨ Para caja de encendido con conexiones tuerca standard use18-5776 – Para caja de encendido con conexiones tipo bala use18-5777
 ⑩ Para caja de encendido con conexiones tipo bala use18-5776 – Para caja de encendido con conexiones tipo bala use18-5778

HP	Modelo	Desde nº de serie	Hasta nº de serie	Juego de contactos	Condensador	Kit encendido	Bobina	Caja Encendido
135		2839369	3293233	—	—	—	—	—
V-135		A904646	& Sup	—	—	—	18-5186 ④	18-5775 ①
140		3293234	3502805	—	—	—	—	—
140		4865678	5327662	—	—	—	—	—
140		5327663	& Sup	—	—	—	18-5186 ④	18-5775 ①
140 Jet		D082000	G960499	—	—	—	18-5186 ④	18-5775 ①
150		3502806	4865677	—	—	—	—	—
150 XS		4868648	5327662	—	—	—	—	—
150	V135	A904646	G960499	—	—	—	18-5186	18-5775
150	V135	G960500	T178499	—	—	—	—	—
V-150	ORGOIL	4868998	A904645	—	—	—	—	18-5775 ①
V-150	BLUCOIL	4868998	A904645	—	—	—	18-5186	—
V-150		5129480	G960499	—	—	—	18-5186 ④	18-5775 ①
V-150 XR2		6616991	A904645	—	—	—	18-5186 ④	18-5775 ①
V-150 XR4		B242885	D819999	—	—	—	18-5186 ④	18-5775 ①
V-150		G960500	& Sup	—	—	—	—	—
V-150 XR6		D082000	T408999	—	—	—	—	①
V-150	EFI	T409000	& Sup	—	—	—	—	—
V-150	DFI	G590000	B490865	—	—	—	18-5187	—
V-150	DFI	B490866	& Sup	—	—	—	—	—
V-150	PRO XS	B690542	& Sup	—	—	—	—	—
V-175		4301235	5180108	—	—	—	—	18-5775 ①
V-175,EFI, XR1		5180109	G960499	—	—	—	18-5186 ④	18-5775 ①
V-175 EFI		D000750	G960499	—	—	—	18-5186	—
V-175 EFI		G960500	T408999	—	—	—	—	—
V-175 EFI		T409000	T800999	—	—	—	—	—
V-175 DFI		T178500	B490865	—	—	—	18-5187	—
V-175 DFI		B490866	& Sup	—	—	—	—	—
V-175 PRO		B516339	& Sup	—	—	—	—	—
V-200	ORGOIL	4839034	5363917	—	—	—	—	①
v-200	BLUCOIL	4839034	5363917	—	—	—	—	—
V-200, XR1		5363918	G960499	—	—	—	18-5186 ④	18-5775 ①
v-200		G960500	& Sup	—	—	—	—	—
V-200 EFI		C100861	G960499	—	—	—	18-5186	—
V-200 EFI		G303046	T408999	—	—	—	—	—
V-200 EFI	2.5L	T409000	& Sup	—	—	—	—	—
V-200 EFI	3.0L	T750164	& Sup	—	—	—	—	—
V-200 DFI		G386496	G589999	—	—	—	18-5183	—
V-200 DFI		G590000	B504988	—	—	—	18-5187	—
V-200 DFI		B504989	& Sup	—	—	—	—	—
V-200 PRO		B504989	& Sup	—	—	—	—	—
V-220		B117316	& Sup	—	—	—	18-5186 ④	18-5775 ①
V-225	2.4L	5628028	& Sup	—	—	—	18-5186 ④	18-5775 ①
V-225	3.0L	D280813	G303045	—	—	—	—	—
V-225	3.0L	G303046	T408999	—	—	—	—	—
V-225	3.0L	G245605	G303045	—	—	—	—	—
V-225	3.0L	G303046	T408999	—	—	—	—	—
V-225 EFI	3.0L	G129222	G303045	—	—	—	—	—
V-225 EFI	3.0L	G303046	T408999	—	—	—	—	—
V-225 EFI	3.0L	T409000	& Sup	—	—	—	—	—
V-225 DFI		G590000	B504988	—	—	—	18-5187	—
V-225		B504989	& Sup	—	—	—	—	—
V-225 PRO		B104549	B426650	—	—	—	18-5187	—
V-225 PRO		B426561	& Sup	—	—	—	—	—
V-250 EFI	3.0L	G129222	T408999	—	—	—	—	—
V-250 EFI	3.0L	T409000	& Sup	—	—	—	—	—
V-250	3.4L	C101891	& Sup	—	—	—	18-5186	—
V-250 DFI		B528615	& Sup	—	—	—	—	—
V-250 PRO		B426561	& Sup	—	—	—	—	—
V-275	3.4L	C101891	& Sup	—	—	—	18-5186	—
V-300	3.4L	5611648	& Sup	—	—	—	18-5186	—

- ① Necesarias 2 unids. ② Necesarias 3 unids. ③ Necesarias 4 unids. ④ Necesarias 6 unids. ⑤ Sólo Phelon Magneto ⑥ Sólo arranque manual
 ⑦ Sólo Bendix Scintilla Magneto ⑧ Excepto "Gnat"
 ⑨ Para caja de encendido con conexiones tuerca standard use 18-5776 - Para caja de encendido tipo bala use 18-5777
 ⑩ Para caja de encendido con conexiones tuerca standard use 18-5776 - Para caja de encendido tipo bala use 18-5778

CABLES DE BUJÍAS DE ALTO RENDIMIENTO

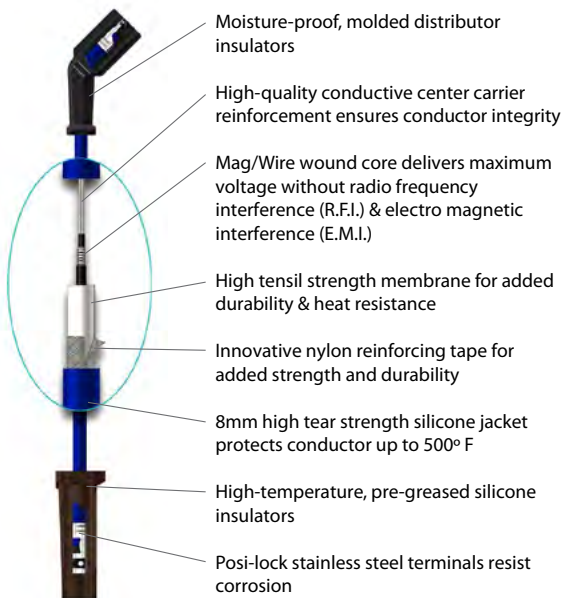

Los cables de bujías Sierra protegen de interferencias los dispositivos electrónicos. Fácil instalación y libre de mantenimiento.



Referencia	OEM #	Descripción
18-8819-1	—	Cable de bujía 18 cm (8mm)
18-5228-1	—	Cable de bujía 23 cm (8mm)
18-5228-1D③	84-813715A1	Cable de bujía 23 cm (8mm)
★ 18-5227-1	—	Cable de bujía 23 cm (7mm)
18-5227-1D②③	84-813715A1	Cable de bujía 23 cm (7mm)
18-5229-9-1①②	—	Cable de bujía 56 cm (7mm)
18-5230-9-1①②	—	Cable de bujía 25 cm(7mm)

★ Cable de alma metálica ① pack de 5 ② 7mm alma de cobre
 ③ Referencias acabadas en D envasadas

**18-5225
KIT CABLE BUJÍAS**

Reemplaza:
84-99215A26, 84-813706A26, 84-93475A26, 84-93212A1,
84-90816A26
Kit incluye 25 ft. de cable de encendido 7 MM Hypalon con conductor de cobre y un largo surtido de 3 terminales diferentes para motores fueraborda.



**18-5226
CABLE ENCENDIDO**

Interior metálico
30 mts Bobina
7mm Hypalon



PACK DE 10



**18-5224
18-5224-9①**
TERMINAL CABLE BUJÍAS
Reemplaza: 20121, 8M0084600

PACK DE 10



**18-5750
18-5750-9①**
TAPA DE BUJÍAS UNIVERSAL
Suministrado completo con conector terminal



**18-5752
BUJÍA UNIVERSAL**
8mm



**18-28080
JUEGO DE CABLES**
Reemplaza: 84-821945A56
Para: 225(3.0L Carb) Y 225/250(3.0L EFI)
(G303045 & Inf.)



**18-28081
JUEGO DE CABLES**
Reemplaza: 84-813706A56
Para: 225(3.0L Carb) y 225/250(3.0L EFI) w/CDM Modulos (G303045 & sup.)



**18-28082
JUEGO DE CABLES**
Reemplaza: 84-813715A8
Para: 100, 115, 125 & 80 Jet(4 cil)
(G301751 & Sup)



**18-28083
CABLE BUJÍA**
Reemplaza: 84-881908T
(1 cable)
Para: Mercury V6 EFI/DFI/DTS



**18-28084
JUEGO DE CABLES BUJÍA**
Reemplaza: 84-881908T
(3 cables)
Para: Mercury 30-40 EFI 4-tiempos(3 cil)



**18-28085
JUEGO DE CABLES BUJÍA**
Reemplaza: 84-881908T
(4 cables)
Para: Mercury 40-6- EFI 4-tiempos (4 cil)



**18-28086
JUEGOS DE CABLE BUJÍA**
Reemplaza: 84-881908T
(6 cables)
Para: Mercury V6 EFI/DFI/DTS



**MP41000
LLAVE DE ENCENDIDO**
Pulse para arrancar —
3 Posiciones — 6 Terminales
Reemplaza: 87-88107, 87-88107A5



**MP41070-2
LLAVE DE ENCENDIDO**
Pulse para arrancar —
3 Posiciones — 6 cables
Reemplaza: 87-17009A2



**MP51090 (Display)
MP51092
LLAVE DE ENCENDIDO**
3 Posiciones Magneto — OFF- RUN-
Pulse para arrancar
Reemplaza: 87-17009A5



**MP52000 (Display Pkg.)
MP52002
LLAVE DE ENCENDIDO**
3 Posiciones Magneto — OFF- RUN-
Pulse para arrancar — 8 cables
Reemplaza: 87-88107A5



**18-6751
VÁLVULA**
Reemplaza: 893929A01, 813442A2,
813442A1, 811618A1, 811618,
812843A1, 99660A1
Para: Mayoría de 2x4 tiempos con trim y
tit integral.



**18-6771
DEPÓSITO TILT/TRIM**
Reemplaza: 18525A1



18-6778
DEPÓSITO TILT/TRIM
Reemplaza: 88316A1
Para: Motores con 4 tornillos de anclaje

(2 cables con relés)



18-6273-1
MOTOR TILT/TRIM
Bomba en cartucho de altas prestaciones con motor reemplazable
Reemplaza: 99186, 99186-1, 99186-T
Para: 35-220 HP (1985-93) Fuerabordas Mercury/Mariner con Design I, 3 Ram, 3 Cables, unidades Tilt/Trim con depósito Trim/Tilt
Use relé 18-5737



18-6757
MOTOR TILT/TRIM
Para: Mercury 35-220 HP (1985-92) con diseño I, 3-Ram Llenado lateral Trim/Tilt Sistema tipo cuadrado Motor y 18-6273-1 Tilt/Trim Montaje de bomba de motor Usar cableado 18-6823

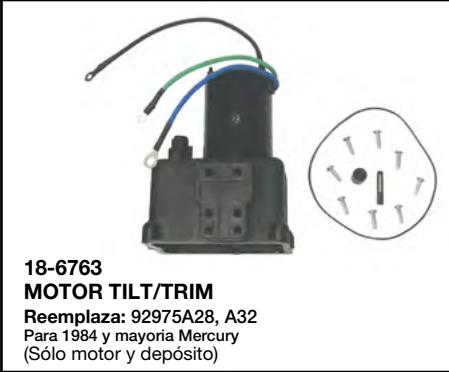

18-6763
MOTOR TILT/TRIM
Reemplaza: 92975A28, A32
Para 1984 y mayoría Mercury (Sólo motor y depósito)



18-6765
MOTOR TILT/TRIM
Reemplaza: 823653A5, 92459A4, 823653A9
Para: 250,275 HP & V-3.4L, N° serie.5611648-sup (Sólo Motor)
Reemplaza: 17649A02



18-6773
MOTOR TRIM
Reemplaza: 828708, 878265A4
Para últimos modelos Mercury/Mariner 1996 & sup (135,150, XR6 Mag III, 175, 200, 225, 250 HP – 105 - 140 HP Jet)



18-6774
MOTOR TRIM
Reemplaza: 811628, 828708A1, 878265A6
Cartucho de alto rendimiento, Motor reemplazable. Design II, Ram 3, 2 cables, Unidades tilt/trim. Estilo cuadrado Eaton
Use cableado 18-6823

18-6775
TILT/TRIM MOTOR
Referencia OE depósito 811673 1
Contiene: Todas las partes necesarias, Un nuevo depósito 3-cables motor/depósito, acoplamiento de eje, retén aceite, Aros y tornillería.
Tapón llenado amarillo.
Para:

Modelos	Modelos
65 Jet	100 4-Cil.
75 3-Cil.	115 4-Cil.
80 Jet	125 4-Cil.
90 3-Cil.	

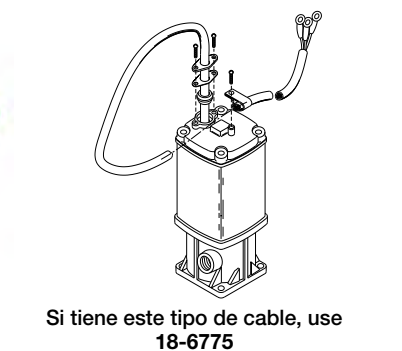

Si tiene este tipo de cable, use **18-6775**

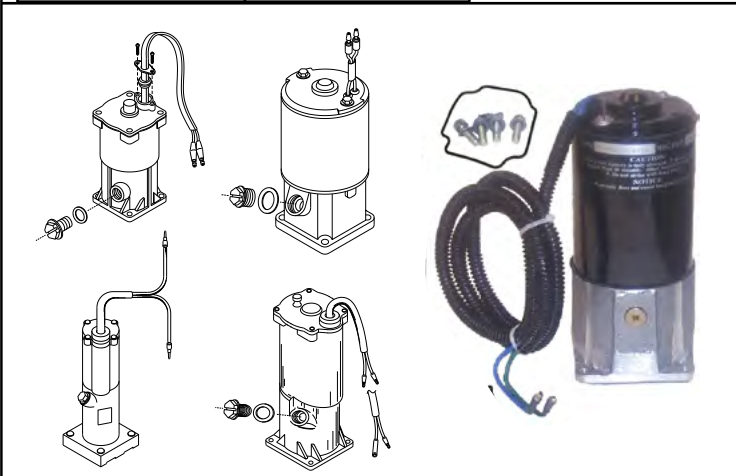

Si tiene este tipo de cables, use **18-6777**

18-6777
MOTOR TILT/TRIM
Reemplaza: 818903A1, 819762A4-A7, 819479A1, 819480A1, 81977A8-A9, 822870A1, 830250A3-T3, 832021A1-T4-A2-T2, 855654A1-T2, 19217A1-A5, 854472A2, A3, A4
Contiene: Todas las partes necesarias, un nuevo depósito 2- cables motor/ depósito, eje, retén aceite, Aros y tornillería. Tapón llenado amarillo. Base cuadrada.
Para:

Modelos	Modelos
30 Jet	60 3-Cil., Bigfoot
30 4-Tiempos	65 Jet
35	75 3-Cil.
40 2, 3, 4-Cil.	75 4-Tiempos
40 4-Tiempos, Bigfoot	80 Jet
45 4-Tiempos, Bigfoot, Bodensee	90 3-Cil.
	90 4-Tiempos
50 3-Cil.	100 4-Cil.
50 4-Tiempos, Bigfoot	115 4-Cil.
55 3-Cil.	125 4-Cil.



18-6448
KIT CONVERSIÓN ARRANQUE ELÉCTRICO
Para: Mecury 30 HP

18-6274
MOTOR TILT/TRIM
Reemplaza: 14336A20, 865380A13
Baja presión / Alto caudal



CABLES BATERÍA

Terminales que aceptan tornillos 3/8".

Ref.	Medida	Color	Salidas	Ref.	Talla	Color	Salidas
BC88523	2'	rojo	4	BC88563	6'	rojo	2
BC88533	2'	negro	4	BC88573	6'	negro	2
BC88543	4'	rojo	2	BC88583	8'	rojo	1
BC88553	4'	negro	2	BC88593	8'	negro	1



18-9800
TESTER COMPRESIÓN
Idóneo para lugares de difícil acceso.



18-9801
MULTI METER/DVA TESTER
Reemplaza: 91-99750A1
Para sistemas de arranque mercury



18-9802
LUZ CRONOMETRAJE
Reemplaza: 91-99379
Hasta 10,000 RPM's.



18-5863
STATOR
Reemplaza: 86617A17
Para: 15-25 HP



18-5864
STATOR
Reemplaza: 86617A20
Para: 6-25 HP



18-5865
STATOR
Reemplaza: 398-5704A7
Para: 50-70 HP



18-5867
STATOR
Reemplaza: 398-9873A4
Para: 135-200 V-6



18-5870
STATOR
Reemplaza: 398-832075A4-A21
Para: 30-125 HP
Reemplazo para kits 18-5873 & 18-5874



18-5871
STATOR
Reemplaza: 398-5454A32
Para: 135-300 V6



18-5873
KIT STATOR
Reemplaza: 398-832075A6
Para: 100, 115, 125 HP
Incluye 18-5870 stator



**18-5874
KIT STATOR**

Reemplaza: 398-832075A14, 398-832075A20,
398-818535A15, 398-5919A8, 398-5919A6,
398-5919A2, 398-5454A63, 398-5454A25,
398-5454A21

Para: 30-50 HP
Incluido 18-5870 stator



**18-5876
STATOR**

Reemplaza: 398-9610A19
Para: 135 -200 HP



**18-5854
STATOR**

Reemplaza: 398-5454A17
*Nota: cable extra negro va a toma motor.



**18-5855
STATOR**

Reemplaza: 336-3996A7



**18-5856
STATOR**

Reemplaza: 398-5255



**18-5857
STATOR**

Reemplaza: 398-5454A7



**18-5859
STATOR**

Reemplaza: 398-5454A26, 398-5454A22, 398-5919A7, 398-5919A3



**18-5860
STATOR**

Reemplaza: 398-5454A35



**18-5798
TRIGGER**

Reemplaza: 96455A9, 96455A6, 68162A8, 68162A5, 68162A1
Para: 6 cil



**18-5797
TRIGGER**

Reemplaza: 96455A8, 96455A1, 68162A6, 68162A3
Para: 3 cil.



APLICACIONES STATOR Y TRIGGER

HP	DESDE	HASTA	Trigger	Stator	HP	DESDE	HASTA	Trigger	Stator
6	A197112	G760299	—	18-5864	125 4 cil	G438000	& Sup	—	18-5870 **
7.5	2810637	3274632	—	18-5855	125 4 cil (Belgica)	9927000	& Sup	—	18-5870 **
8	A197112	G760299	—	18-5864	125 4 cil con regulador de voltaje.	D283222	G437999	—	18-5873 **
9.8	2798057	3263262	—	18-5855	125 4 cil con regulador de voltaje				
9.9	A197112	G760299	—	18-5864	(Belgica)	9793577	9926999	—	18-5873 **
XR10,10 MAG & SEA PRO	D038000	G760299	—	18-5864	V135	A904646	C100860	18-5798	18-5860 ②
15	A197112	G760299	—	18-5864	V135	A904646	C100860	18-5798	18-5871
15 SEA PRO, SUPER 15	G044365	G437999	—	18-5863	V135	C100861	C239552	18-5798	—
15 SEA PRO, SUPER 15	G438000	G760299	—	18-5864	V135	C239553	D081999	18-5798	18-5860 ③
18	5837437	6443972	—	18-5864	V135	C239553	D081999	18-5798	—
18XD	6443973	B238463	—	18-5864	V135	C239553	D081999	18-5798	18-5867 ③⑥
20	2827677	3226957	—	18-5855	V135	D082000	G960499	18-5798	18-5876
20	6443973	G044026	—	18-5864	140	5327663	& Sup	18-5798	18-5854
20, 20 JET	G044027	G437999	—	18-5863	140 JET	UP TO	G760299	18-5798	18-5876
20, 20 JET	G438000	G760299	—	18-5864	V150	4868998	A904645	18-5798	18-5857
20XD	6443973	B238463	—	18-5864	V150	A904646	C100860	18-5798	18-5860 ②
25	5705532	6443972	—	18-5864	V150	A904646	C100860	18-5798	18-5871
25, 25 SEA PRO & MARATHON	B238464	G044026	—	18-5864	V150	C100861	C239552	18-5798	—
25, 25 SEA PRO & MARATHON	G044027	G437999	—	18-5863	V150	C239553	D081999	18-5798	18-5860 ③
25, 25 SEA PRO & MARATHON	G438000	G760299	—	18-5864	V150	C239553	D081999	18-5798	— †
25XD	5705532	G044026	—	18-5864	V150	C239553	D081999	18-5798	18-5867 ③⑥
30 2 cil modelo eléctrico	G055314	& Sup	—	18-5870 **	V150	D082000	G960499	18-5798	18-5876
30 JET 3 cil modelo eléctrico	G590000	T408999	—	18-5870 **	V150 EFI	D082000	G960499	18-5798	18-5876
30 Jet 4 cil modelo eléctrico	C159200	D055047	—	18-5874 **	V150 XRI EFI	D082000	G303045	18-5798	18-5876
35 2 cil	6445653	B110788	—	18-5864	150 XR-4	B242885	C100860	18-5798	18-5860
40 2 cil	3859435	5823917	—	18-5856 ①	150 XR-4	C100861	C239552	18-5798	—
40 2 cil encendido eléctrico	G055314	& Sup	—	18-5870 **	150 XR-4	C239553	D081999	18-5798	18-5860 ③
40 3 cil encendido eléctrico	G531301	& Sup	—	18-5870 **	150 XR-4	C239553	D081999	18-5798	— †
40 3 cil encendido eléctrico (Bélgica)	9973100	& Sup	—	18-5874 **	150 XR-4	C239553	D081999	18-5798	18-5867 ③⑥
40 4 cil encendido eléctrico	C159200	D055047	—	18-5874	150 XR-4, MAG II	C239553	D081999	18-5798	—
40 JET encendido eléctrico	T178500	& Sup	—	18-5874 **	150 XR-4, MAG II	C239553	D081999	18-5798	18-5867 ③⑥
45 4 cil sólo encendido manual	5531630	B110788	—	18-5866	150 XR-6, MAG III	D082000	G960499	18-5798	18-5876
45 4 cil modelo eléctrico	5531630	& Sup	—	18-5870	V175	4301235	6618750	18-5798	18-5857
45 JET modelo eléctrico	G590000	T129554	—	18-5874 **	V175	6618751	C100860	18-5798	18-5871 ④
50 4 cil sólo arranque manual	4357640	& Sup	—	18-5866	V175	6618751	C100860	18-5798	18-5857 ④
50 4 cil modelo eléctrico	4357640	& Sup	—	18-5870	V175	6618751	C100860	18-5798	18-5860 ⑤
50 3 cil	6428681	D000749	18-5797	18-5865	V175	C100861	C239552	18-5798	—
50, 55 3 cil encendido eléctrico	G590000	& Sup	—	18-5870 **	V175	C239553	D081999	18-5798	18-5860 ③
50 3 cil modelo eléctrico (Bélgica)	9973100	& Sup	—	18-5870 **	V175	C239553	D081999	18-5798	18-5867 ③⑥
55 3 cil modelo eléctrico	D000750	G589999	—	18-5870 **	V175	C239553	D081999	18-5798	— †
55 3 cil modelo eléctrico (Bélgica)	9741042	9973088	—	18-5870 **	V175	D082000	G960499	18-5798	18-5876
60 3 cil	6428681	D000749	18-5797	18-5865	V175 MAG, EFI	D000750	D081999	18-5798	—
60 3 cil modelo eléctrico	G590000	& Sup	—	18-5870 **	V175 EFI	D303046	G960499	18-5798	18-5876
60 3 cil modelo eléctrico (Bélgica)	9973100	& Sup	—	18-5870 **	V175 XRI EFI	D000750	D081999	18-5798	—
60 3 cil Bigfoot	G590000	G760299	—	18-5874 **	V175 XRI EFI	D082000	G303045	18-5798	18-5876
65 (650) 3 cil	4382057	4571651	—	18-5865	V200	4839034	6625220	18-5798	18-5857 ④
70 3 cil	4571652	A996141	18-5797	18-5865	V200	6618751	C100860	18-5798	18-5860 ⑤
75 4 cil	6432901	& Sup	—	18-5859	V200	C100861	D081999	18-5798	18-5860 ③
75 3 cil modelo eléctrico	G438000	& Sup	—	18-5870	V200	C100861	C291519	18-5798	— †
80 (80, 800) 4 cil	4831999	6432900	—	18-5859	V200	C100861	C291519	18-5798	18-5867 ③⑥
80 JET	G438000	& Sup	—	18-5870 **	V200	D082000	G960499	18-5798	18-5876
85 (850) 4 cil	4366802	4831998	—	18-5859	V200 EFI	C100861	OD081999	18-5798	—
90 6 cil	5299506	& Sup	18-5798	18-5854	V200 EFI	G303046	G960499	18-5798	18-5876
90 3 cil modelo eléctrico	G438000	& Sup	—	18-5870	V200 XRI EFI	C291520	D081999	18-5798	— †
90 3 cil (Belgica) modelo eléctrico	9927000	& Sup	—	18-5870	V200 XRI EFI	D082000	G960499	18-5798	18-5876
100 4 cil	G438000	& Sup	—	18-5870 **	V220	B117316	& Sup	—	18-5860
100 4 cil	9927000	& Sup	—	18-5870 **	V225	5628028	& Sup	18-5798	18-5857
100 4 cil con regulador de voltaje.	B209468	G437999	—	18-5873 **	SPORTJET MODELOS				
100 4 cil con reg. de volt. (Bélgica)	9523024	9926999	—	18-5873 **	90	ALL W/RED STATOR			18-5870
105 JET	D082000	G960499	18-5798	18-5876	95XR	ALL W/RED STATOR			18-5870
115 6 cil	5314656	& Sup	18-5798	18-5854	120XR	ALL W/RED STATOR			18-5870
115 4 cil modelo eléctrico	G438000	& Sup	—	18-5870 **	175XR2	ALL			18-5796
115 4 cil modelo eléctrico (Bélgica)	9927000	& Sup	—	18-5870 **					—
115 4 cil con regulador de voltaje.	C10000	G437999	—	18-5873 **					
115 4 cil con reg. de volt. (Bélgica)	9559771	9926999	—	18-5873 **					

① Sólo modelos de arranque eléctrico

② Sólo stators de 5/8".

③ Para regulador de voltaje 16A y tapa de volante sin ventilación

④ Para uso sin regulador de voltaje

⑤ Stators con 5/8" con 15 amp de regulador de voltaje

** Puede requerir la compra de regulador de voltaje si no está actualmente equipado

† Aplicaciones con starter de 40 amp.

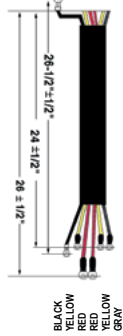

**18-5741
REGULADOR DE VOLTAJE**

Reemplaza: 815279A2, 815279-1
Para: Motores mercury con modelos de cargador 16 amp o 40 amp años1989-91

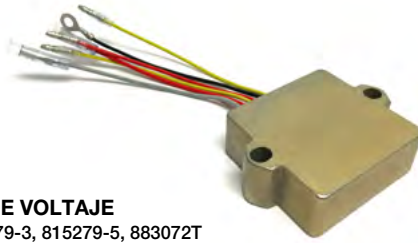

**18-5743
REGULADOR DE VOLTAJE**

Reemplaza: 815279-3, 815279-5, 883072T
Para: Motores mercury con modelos de cargador 16 amp o 40 amp años 1992 y siguientes
*Nota: Cable negro va a tierra

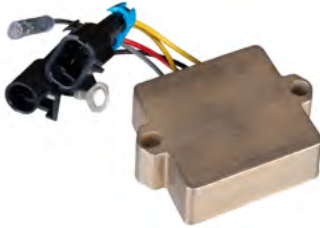

**18-5732
REGULADOR DE VOLTAJE**

Reemplaza: 893640T01
Para: 30/40/50/60 EFI 4 Tiempos



**18-5707
RECTIFICADOR**

Reemplaza: 62351A1, 62351A2, 816770, 816770T
Todas las aplicaciones cuadradas

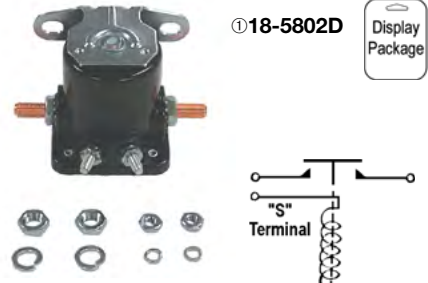

**18-5802
SOLENOIDE**

Reemplaza: 65057A1, 65057T1, 65057, 54981



**18-5808
SOLENOIDE**

Reemplaza: 47886, 47886T

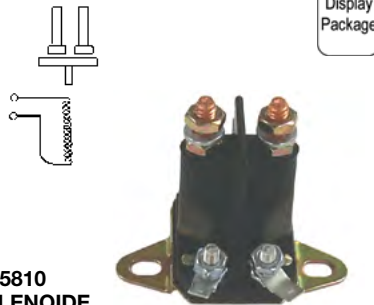

**18-5810
SOLENOIDE**

Aplicación horizontal



**18-5811
SOLENOIDE**

Reemplaza: 809463A1, 8094631, 809463, 8094621, 809462
Para: PG260 Series Starters, (Verado 200-275 HP), (75/95 1.5L DFI), (115/135/150/175/200 2.5L DFI), (225 3.0L DFI)

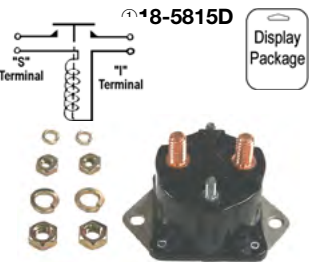

**18-5815
SOLENOIDE**

Reemplaza: 89-68258A4, 89-853654A1, 89-76545, 89-76545T, 89-65258, 89-61053, 89-15857

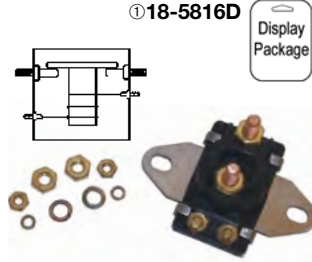

**18-5816
SOLENOIDE**

Reemplaza: 89-96054, 89-96054T, 89-91975
Soporte plano



**18-5817
SOLENOIDE**

Reemplaza: 89-96158, 89-96158T, 94318, 846070
Aplicación vertical

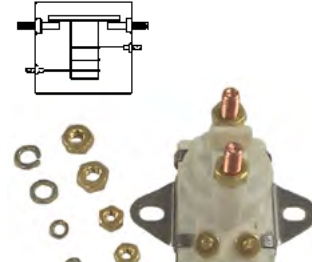

**18-5818
SOLENOIDE**

Reemplaza: 89-818864, 89-818864T

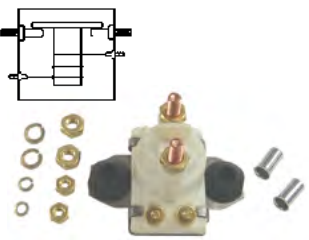

**18-5819
SOLENOIDE**

Reemplaza: 89-818997A1, 89-818997T1, 89-818997A2

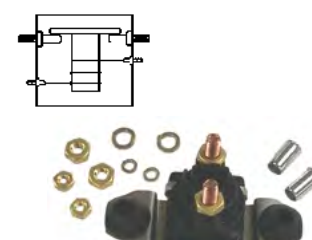

**18-5820
SOLENOIDE**

Reemplaza: 89-818999A2, 89-825842A1, 89-850188T1



**18-5821
SOLENOIDE**

Reemplaza: 89-825096T, 825096T01
Para: 9.9 4-tiempos(1999 & Sup.), 15 4-tiempos (1999 & Sup), 30 4-tiempos (2002 & Sup.), 40/50/60 4-tiempos(2001 & Sup), 75/90 4-tiempos(2000 & Sup.)



**18-5822
SOLENOIDE ARRANQUE**

Reemplaza: 54293A13, 54393A10, 54393A4
Para: 75 4cil (1984 & Sup), V150 (1978 & Sup), V150 Magnum (1978-85), V150 Marathon (1978-85), V150 XR 2 (1978-85), V1500 (1978-85), V175 (1976-99), V1750 (1976-88), V200 (1978 & Sup), V2000 (1978-88)

APLICACIÓN EN LA SIGUIENTE PÁGINA

① Referencias acabadas en D envasadas



**18-5834
SOLENOIDE**
Reemplaza: 89-817109A2
Para: 75 HP (3 cil.) S/N G127500 & Sup

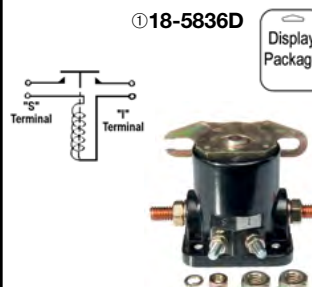

① **18-5836D**
Display Package

**18-5836
SOLENOIDE**
Reemplaza: 25661, 256611, 25661T1



**18-5729
RELE POWER TRIM**
Reemplaza: 87-18211
Para: 35 (2 cil.) (con Ram Trim)
OC159200 & sup
60 (3 cil.) (con Ram Trim)
OB122920 - OD000749



**18-5737
RELE POWER TRIM**
Reemplaza: 87-19761
Para: 40 (4 cil.) (con Relés)
OC159200 & sup



**18-5849
RELÉ, TAPA, TRIM**
Reemplaza: 882751A1,
828151A1, 828151, 882751A2
Para: Power Trim Relé usado en la mayoría
Motores 2T y 4T (no-Verado*).



**18-5850
RELÉ, TAPA**
Reemplaza: 882751A04
Para: 135hp. - 350hp Verado (2005 -
Actual); 496Mag & 496HO (2004 - Actual);
8.1HO (2004 - Actual)



**18-5851
RELÉ, TAPA**
Reemplaza: 865202T,
807057T, 807057



**18-5852
RELÉ, TAPA**
Reemplaza: 821509T01, 821509,
853292
Para: 4- tiempos: 45hp
(0G231123-0G472132); 50hp.
(0G231123-0T178499)

① Referencias acabadas en D envasadas

APLICACIÓN SOLENOIDES

HP	DESDE	HASTA	Starter Solenoide/Relé	Power Trim Relé
4-TIEMPOS				
9.9 (4-tiempos)(323cc)	0G760300	0T979999	18-5821	—
15 (4-tiempos)(323cc)	0G760300	1B727495	18-5821	—
30 (4-tiempos) Carb	0G760300	& Sup	—	18-5849
30 (4-tiempos) EFI	0T409000	1B226999	18-5821	18-5849
40 (4-tiempos)(3 cil) Carb	0G760300	& Sup	—	18-5849
40 (4-tiempos)(3 cil) EFI	0T409000	& Sup	18-5821	18-5849
40 (4-tiempos)(4 cil) Carb	0T228405	0T598999	18-5821	18-5849
40 (4-tiempos)(4 cil) EFI	0T409000	& Sup	18-5821	18-5849
45 (4-tiempos) Bodensee	0G231123	0G472132	18-5821	18-5852
45 (4-tiempos) Bodensee	0G472133	0T178499	18-5821	18-5849
50 (4-tiempos)	0G231123	0T178499	18-5821	18-5852
50 (4-tiempos)(4 cil) Carb 996cc	0T178500	0T598999	18-5821	18-5849
50 (4-tiempos)(4 cil) EFI 996cc	0T409000	& Sup	18-5821	18-5849
60 (4-tiempos)(4 cil) Carb 996cc	0T178500	0T598999	18-5821	18-5849
60 (4-tiempos)(4 cil) EFI 996cc	0T409000	& Sup	18-5821	18-5849
75 (4-tiempos) Carb 1596cc	0G960500	1B226999	18-5821	—
75 (4-tiempos) EFI 1596cc	1B366823	& Sup	18-5834	—
90 (4-tiempos) Carb 1596cc	0G960500	1B226999	18-5821	—
90 (4-tiempos) EFI 1731cc	1B366823	& Sup	18-5821	—
115 (4-tiempos) EFI w/ 2 relé trim	0T178500	0T800999	—	18-5849
115 (4-tiempos) EFI 1731cc	0T809000	1B366822	—	18-5849
115 (4-tiempos) EFI 1731cc	1B366823	& Sup	18-5821	—
135 (4-tiempos) Verado	1B227000	& Sup	18-5850	18-5850
150 (4-tiempos) Verado	1B227000	& Sup	18-5850	18-5850
175 (4-tiempos) Verado	1B227000	& Sup	18-5850	18-5850
200 (4-tiempos)(4 cil) Verado	1B517159	& Sup	18-5850	18-5850
200 (4-tiempos)(6 cil) Verado	0T980000	& Sup	18-5850	18-5850
225 (4-tiempos)(6 cil) Verado	0T980000	& Sup	18-5850	18-5850
250 (4-tiempos)(6 cil) Verado	0T980000	& Sup	18-5850	18-5850
275 (4-tiempos)(6 cil) Verado	0T980000	& Sup	18-5850	18-5850
300 (4-tiempos)(6 cil) Verado	1B517434	& Sup	18-5850	18-5850
350 (4-tiempos)(6 cil) Verado	1B716557	& Sup	18-5850	18-5850

2-Tiempos					
HP	Desde	Hasta	Starter Solenoide	Power Trim Solenoide	Power Trim Relé
6/8/9.9	A197112	OD280999	18-5816	—	—
15	A197112	OD280999	18-5816	—	—
18	5837437	& Sup	18-5816	—	—
20	4709593	6443972	18-5815	—	—
20	6443973	0G044026	18-5816	—	—
25	5705532	G044026	18-5816	—	—
30 (2 cil) 644cc	G053314	& Sup	—	—	18-5849
30 JET non-handle	C159200	G589999	18-5816	—	—
35 2 cil (w/ 3 Ram Trim)	6445653	C159199	18-5817	18-5817	—

① Use 18-5817 para aplicaciones con interruptor fusible
 ② Para unidades con terminales 8-32, 1/4-20 .
 ③ Para unidades con terminales 10-32, 5/16-18.
 ④ Use 18-5818 se necesita solenoide blanco
 ⑤ Para aplicaciones diseño II use 18-5820.
 ⑥ Solenoide con casquillo de goma

APLICACIÓN SOLENOIDES

HP	DESDE	HASTA	Starter Solenoide	Solenoide Power trim	Relé Power trim
35 2 cil (w/ 1 Ram Trim)	C159200	& Sup	18-5817	—	18-5729
40 2 cil	2874704	5556229	18-5836	—	—
40 2 cil	5556230	5823917	18-5815	—	—
40 2 cil	5823918	G053313	18-5817	—	—
40	G053314	& Sup	18-5816 ⑤	—	—
40 4 Cil. (solenoide)	C159200	& Sup	18-5816	18-5820	—
40 4 Cil. (con/relés)	C159200	& Sup	18-5816	—	18-5737
45 4 Cil. (disyuntor)	5531630	6146848	18-5815	18-5815	—
45 4 Cil. (disyuntor)	5531630	6146848	18-5815	18-5817	—
45 4 Cil. (disyuntor)	6146849	B110788	18-5817	18-5815 ①	—
45 4 Cil. (disyuntor)	6146849	B110788	18-5817	18-5817	—
45 4 Cil.	B110789	& Sup	18-5817	18-5817	—
45 JET (solenoide)	D000750	G290584	18-5816	—	—
45 JET	G290585	G589999	18-5820	—	—
50	3008819	4140999	18-5836	—	—
50	4141000	5531629	18-5815	—	—
50 4 Cil. (Disyuntor)	5531630	6146848	18-5815	18-5815 ①	—
50 4 Cil. (Disyuntor)	5531630	6146848	18-5815	18-5817	—
50 4 Cil. (Disyuntor)	6146849	& Sup	18-5817	18-5815 ①	—
50 4 Cil. (Disyuntor)	6146849	& Sup	18-5817	18-5817	—
50 3 Cil.	6428681	B122929	18-5816	18-5817	—
50 3 Cil. (con/ 3 Ram Trim)	B122930	C160935	18-5817	18-5817	—
50 3 Cil. (con/ 1 Ram Trim)	B122930	D000749	18-5817	—	18-5729
50 3 Cil.	D000750	G290584	18-5816	—	18-5849
50 3 cil	G290585	G589999	18-5820	—	18-5849
50 3 cil	G590000	& Sup	—	—	18-5849
55 3 Cil.	D000750	G290584	18-5816 ⑤	—	18-5849
55 3 Cil.	G290585	G589999	18-5820	—	18-5849
60 3 Cil.	6428681	B122929	18-5816	18-5817	—
60 3 Cil. (solenoide)	B122930	D000749	18-5817	18-5817	—
60 3 Cil. (con/relés)	B122930	D000749	18-5817	—	18-5729
60 3 Cil.	D000750	G290584	18-5816 ⑤	—	18-5849
60 3 Cil.	G290585	G589999	18-5820	—	18-5849
65 4 Cil.	2446775	3293183	18-5836	—	—
65 3 Cil.	3547987	4571651	18-5815	—	—
65 JET	G127500	& Sup	18-5834	—	—
70 3 Cil.	4571652	5579016	18-5815	—	—
70 3 Cil.	5579017	6104369	18-5815	18-5815 ①	—
70 3 Cil.	6104370	6428680	18-5816	18-5815 ①	—
70 3 Cil.	A996147	& Sup	18-5817	18-5817	—
75 4 Cil.	6432901	& Sup	18-5816	18-5817	—
75 3 cil w/ 1 Ram Trim	C222000	D252460	—	—	18-5849
75 3 Cil.	D252461	G127499	18-5817	18-5819	—
75 3 Cil.	G127500	G360002	18-5834	18-5819	—
75 3 Cil.	G360003	& Sup	18-5834	—	18-5849
75 Optimax 3 cil (1.5L)	T801000	& Sup	18-5834	—	18-5849
80	2559001	3493912	18-5836	—	—
80 4 Cil.	4831999	5582561	18-5815	—	—
80 4 Cil.	5582562	6030903	18-5815	18-5815 ①	—
80 4 Cil.	6030904	6432900	18-5816	18-5815 ①	—
80 3 Cil.	A996142	& Sup	18-5817	18-5817	—
80 JET 4 cil	D283222	& Sup	18-5834	—	—
80 JET 3 cil	B586067	& Sup	18-5834	—	18-5849
85 4 Cil.	3493913	3865694	18-5836	—	—
85 4 Cil.	3865695	4831998	18-5815	—	—
90	4845301	5299505	18-5815	18-5815	—
90	5299506	6026608	18-5815	18-5815 ①	—
90	6026609	6436122	18-5816	18-5815 ①	—
90	6436123	& Sup	18-5816	18-5817	—
90 3 Cil.	A996142	C221999	18-5817	18-5817	—
90 3 Cil. w/ 1 Ram Trim	C222000	D252460	—	—	18-5849
90 3 Cil.	D252461	G127499	—	18-5819	—
90 3 Cil.	G127500	G360002	18-5834	18-5819	—
90 3 Cil.	G360003	& Sup	18-5834	—	18-5849
90 Optimax 3 cil (1.5L)	T801000	& Sup	18-5834	—	18-5849
100 6 Cil.	2318586	3253111	18-5836	—	—
100 4 Cil. w/ 1 Ram Trim & 5/16-18 terminal	B209468	D252460	18-5834	—	18-5849
100 4 Cil. w/ 3 Ram Trim & 5/16-18 terminal	B209468	D252460	18-5834	—	—
100 4 Cil.	D252461	G359967	18-5834	18-5819	—
100 4 Cil.	G359968	& Sup	18-5834	—	18-5849
105 JET solenoide	D082000	G303045	18-5815	—	—
105 JET solenoide de goma	D082000	G303045	18-5834	—	—
105 JET	G303046	& Sup	18-5834	—	—
110 6Cil.	1870204	2314955	18-5836	—	—
115	2836019	4112634	18-5836	18-5836	—
115	4112635	5600966	18-5815	18-5815	—
115	5600967	6051525	18-5815	18-5815 ①	—
115	6051526	6436122	18-5816	18-5817 ①	—
115	6436123	& Sup	18-5816	18-5817	—
115 4 Cil. w/ 3 Ram Trim & 5/16-18 starter terminal	C100000	D252460	18-5834	—	—
115 4 Cil. w/ 1 Ram Trim & 5/16-18 starter terminal	C100000	D252460	18-5834	—	18-5849
115 4 Cil.	D252461	G359967	18-5834	18-5819	—
115 4 Cil.	G359968	& Sup	18-5834	—	18-5849
115 Optimax 3 cil (1.5L)	T801000	& Sup	18-5834	—	18-5849

① Use 18-5817 para aplicaciones con interruptor fusible
 ② Para unidades con terminales 8-32, 1¼-20 .

③ Para unidades con terminales 10-32, 5/16-18.
 ④ Use 18-5818 se necesita solenoide blanco

⑤ Para aplicaciones diseño II use 18-5820.
 ⑥ Solenoide con casquillo de goma

APLICACIÓN SOLENOIDES

HP	DESDE	HASTA	Starter Solenoide	Power Trim Solenoide	Power Trim Relé
115 Pro XS	B751825	& Sup	18-5834	—	18-5849
125	2314956	3253111	18-5836	—	—
125 4 Cil.	D283222	G359967	18-5834	18-5819	—
125 4 Cil.	G359968	& Sup	18-5834	—	18-5849
125 Optimax 3 cil (1.5L)	B736885	& Sup	18-5834	—	18-5849
135	2839369	3293233	18-5836	—	—
V135	A904646	C100860	18-5815 ③	18-5817	—
V135	A904646	C100860	18-5816 ②	18-5817	—
V135	C100861	C239552	18-5815	18-5817	—
V135	C239553	D081999	18-5815 ④	18-5817	—
V135 (con solenoide montado)	D082000	G201874	18-5815	18-5819	—
V135 (con solenoide cojinete goma)	D082000	G201874	18-5834	18-5819	—
V135 (con solenoide montado)	G201875	G303045	18-5815	—	18-5849
V135 (con solenoide cojinete goma)	G201875	G303045	18-5834	—	18-5849
V135	G303046	& Sup	18-5834	—	18-5849
V135 DFI	G590000	& Sup	18-5834	—	18-5849
140	3293234	3502805	18-5836	18-5836	—
140	4865678	& Sup	18-5815	18-5815	—
140 JET	G303046	T178499	18-5834	—	18-5849
150	3502806	4121434	18-5836	18-5836	—
150	4121435	4865677	18-5815	18-5836	—
150 XS	4868648	5327662	18-5815	18-5815	—
V150	4868998	6042945	18-5815	18-5817	—
V150	6042946	A904645	18-5816	18-5817	—
V150	A904646	C100860	18-5815 ③	18-5817	—
V150	A904646	C100860	18-5817 ②	18-5817	—
V150	C100861	C239552	18-5815	18-5817	—
V150	C239553	D081999	18-5815 ④	18-5817	—
V150, 150 EFI (con solenoide montado)	D082000	G201874	18-5815	18-5819	—
V150, 150EF (con solenoide cojinete goma)	D082000	G201874	18-5834	18-5819	—
V150, 150 EFI (con solenoide montado)	G201875	G303045	18-5815	—	18-5849
V150, 150EF (con solenoide cojinete goma)	G201875	G303045	18-5834	—	18-5849
V150, 150 EFI	G303046	& Sup	18-5834	—	18-5849
V150 DFI	G590000	& Sup	18-5834	—	18-5849
150 XR-4/Magnum II	B242885	C239552	18-5815	18-5817	—
150 XR-4/Magnum II (solenoide standard color)	C239553	D081999	18-5815	18-5817	—
150 XR-4/Magnum II (solenoide blanco off)	C239553	D081999	18-5815	18-5818 ⑤	—
150 XR-6/Magnum III (con solenoide montado)	D082000	G201874	18-5815	18-5819	—
150 XR-6/Magnum III (con solenoide montado goma)	D082000	G201874	18-5834	18-5819	—
150 XR-6/Magnum III	G201875	G303045	18-5815	—	—
150 XR-6/Magnum III (con solenoide montado)	G201875	G303045	18-5815	—	18-5849
150 XR-6/Magnum III (con solenoide montado goma)	G201875	G303045	18-5834	—	18-5849
150 XR-6/Magnum III	G303046	& Sup	18-5834	—	18-5849
V175	4301235	6618750	18-5815	18-5815	—
V175	6618751	C239552	18-5816 ②	18-5817	—
V175	6618751	C239552	18-5815 ③	18-5817	—
V175	C100861	C239552	18-5815	18-5817	—
V175	C239553	D081999	18-5815 ④	18-5817	—
V175, 175 EFI (con solenoide montado)	D082000	G201874	18-5815	18-5819	—
V175, 175 EFI (con solenoide montado goma)	D082000	G201874	18-5834	18-5819	—
V175, 175 EFI (con solenoide montado)	G201875	G303045	18-5815	—	18-5849
V175, 175 EFI (con solenoide montado goma)	G201875	G303045	18-5834	—	18-5849
V175, 175 EFI	G303046	& Sup	18-5834	—	18-5849
V175 DFI	G590000	& Sup	18-5834	—	18-5849
V175 Pro XS	B516339	& Sup	18-5834	—	18-5849
V200	4839034	6073191	18-5815	18-5815	—
V200	6073192	6225220	18-5816	18-5817	—
V200	6625221	C100860	18-5816 ②	18-5817	—
V200	6625221	C100860	18-5815 ③	18-5817	—
V200	C100861	C291519	18-5815	18-5817	—
V200 (2.5L)	C291520	D081999	18-5815 ④	18-5817	—
V200 con solenoide montado)	D082000	G201874	18-5815	18-5819	—
V200 con solenoide montado)	D082000	G201874	18-5834	18-5819	—
V200, 200 EFI (con solenoide montado)	D082000	G201874	18-5815	18-5819	—
V200, 200 EFI (con solenoide cojinete goma)	D082000	G201874	18-5834	18-5819	—
V200, 200 EFI (con solenoide montado)	G201875	G303045	18-5815	—	18-5849
V200, 200 EFI (con solenoide cojinete goma)	G201875	G303045	18-5834	—	18-5849
V200, 200 EFI	G303046	& Sup	18-5834	—	18-5849
V200 DFI	G386496	& Sup	18-5834	—	18-5849
V220 (Laser)	B117316	& Sup	18-5815	18-5817	—
V225 2.4L	5628028	& Sup	18-5815	18-5815	—
V225 3.0L	D280813	G129221	18-5834	18-5819	—
V225 3.0L	G129222	G303045	18-5834	18-5819	—
V225 3.0L	G129222	G303045	18-5834	—	18-5849
V225 3.0L	G303046	& Sup	18-5834	—	18-5849
V225 DFI	G590000	& Sup	18-5834	—	18-5849
V225 Sea Pro / Marathon	G245605	& Sup	18-5834	—	18-5849
V225 Pro XS	B104549	& Sup	18-5834	—	18-5849
V225/250 EFI	G129222	& Sup	18-5834	—	18-5849
V250XB	G980600	& Sup	18-5834	—	18-5849
V250 Pro XS	B426561	& Sup	18-5834	—	18-5849
V250/275 (3.4L)	C101891	& Sup	18-5815	18-5817	—
300 (3.4L)	5611648	& Sup	18-5815	18-5817	—

① Use 18-5817 para aplicaciones con interruptor fusible

② Para unidades con terminales 8-32, 1¼-20 .

③ Para unidades con terminales 10-32, 5/16-18.

④ Use 18-5818 se necesita solenoide blanco

⑤ Para aplicaciones diseño II use 18-5820.

⑥ Solenoide con casquillo de goma



18-5929
ALTERNADOR
Reemplaza: 892940T
Todos Verado



18-6454
ALTERNADOR
Reemplaza: 875285T1,
881248T02, 889955T01
5S/I 50 amp montaje bobina
Para: 2.5L



18-6408
ALTERNADOR
Reemplaza: 863077T.
Para: Mercruiser 377 Scorpion 97-Sup. 105Amp.



18-6455
ALTERNADOR
Reemplaza: 875286T,
875286A1, 881247A1
5S/I 50 amp
Para: 1.5L y 3.0L
Para: 200 DFI, 200 DFI/DTS, 225 EFI, 225 EFI, Sea Pro, 225 DFI/DTS, 250 EFI



18-6840
ALTERNADOR
Reemplaza: 50-897755T, 897755T
Para: 75-115HP EFI (4-Tiempos)



18-18000
Reemplaza: 57-892318
Para: 75 DFI (2005-06),
90 DFI (2005-06), 15 DFI (2004-06)

CORREAS

18-18100
Reemplaza: 57-828507Q4
Para: 135 DFI (1998-Sup),
150 DFI (1998-Sup), 175 DFI (2001-Sup)



18-15128
Reemplaza: 57-880566014
Para: Todos verados-135-275HP

CORREAS

18-15129
Reemplaza: 57-828507 1
Para: 200 DFI (1997 & Sup), 225 DFI (1998 & Sup)



18-6816
MOTOR TRIM
Reemplaza: 172588, 173944
Para: 40, 50, 70, y 75HP con eje corto.



TODOS LOS MOTORES DE ARRANQUE SON ROTACIÓN GIRO DERECHAS



18-6500
CABLEADO ALTERNADOR
Reemplaza: 84-881262A2
Para: Optimax (1998-01) Para: Alternadores Delco



18-6435
MOTOR DE ARRANQUE
Reemplaza: 50-888161T,
50-884044T, 50-859377T, 50-893888T
Para: 40,50,60 HP 4 Tiempos 4 Cil, 0P094500 & sup:
50,60 HP EFI 4 Tiempos 4 Cil, 0P153500-Sup



18-6436
MOTOR DE ARRANQUE
Reemplaza: 50-859171T, 50-834749, 50-898265001
Para: 40HP Italy 4 tiempos 0G760300-Sup: 45HP Bodensee 0G760300-Sup: 50HP 4 tiempos 0G760300-Sup: 50HP Bigfoot 4 tiempos 0G760300-Sup



18-6437
MOTOR DE ARRANQUE
Reemplaza: 50-888151T, 50-830308T, 50-859169T, 50-893886T
Para: 25HP 4 tiempos 0G760300 & sup



18-6438
MOTOR DE ARRANQUE
Reemplaza: 50-888160T, 50-884045T, 50-859170T, 50-854636T, 50-893887T
Para: 30,40HP 3 Cil 4 tiempos 0G760300 & Sup



18-6425
MOTOR DE ARRANQUE
Reemplaza: 50-804312T1
Para: 4 tiempos 75 HP, y 90HP excepto Verado



18-6440
MOTOR DE ARRANQUE
Reemplaza: 50-892339T, 50-853329T
Para: 90, V135, V150, V175, V200, 2.5L DFI, 0T178500 & sup: 200, 250HP, 3.0L, 0T467442 & Sup, y en línea 4 y 6 cil. Verados. Modelos con solenoide operado bendix.



18-5601
MOTOR DE ARRANQUE
Reemplaza: 50-55601, 50-55601A2, 50-38890A1
Para: 35-50 HP



18-5602
MOTOR DE ARRANQUE
Reemplaza: 50-67341, 50-58788A3, 50-893891T, 50-44369A1
Para: 35-40 HP, 2 cil. & 50 HP, 4 cil. modelos



18-5642
MOTOR DE ARRANQUE
Reemplaza: 50-66015, 50-66015T, 50-893891T, 50-44369A1
Para: 50-90 HP modelos (1976-99), 10 dientes



18-6282
MOTOR DE ARRANQUE
Reemplaza: 50-8329972, 50-832997003
Para: Mercury V6 Jet (1996 y sup), 8 dientes



18-6283
MOTOR DE ARRANQUE
Reemplaza: 50-8331535, 50-898265008
Para: Mercury 2.5 DFI(1999 y sup), 200HP V6 DFI(1996-99), 225HP V6 DFI(1998 y sup), 3.0L V6(1999 y Sup) 9 dientes
Use Kit piñones 18-5658

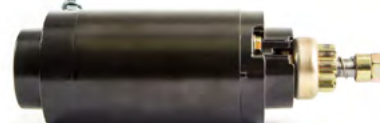

18-5605
MOTOR DE ARRANQUE
Reemplaza: 50-73521, 50-73521T, 50-898265005
Para: 40-50 HP



18-5606
MOTOR DE ARRANQUE
Reemplaza: 50-44369, 50-60315, 50-44369A1 50-898265012
Para: 50-70 HP (1976-94)





18-5608
MOTOR DE ARRANQUE
 Reemplaza: 50-44415, 50-77141, 50-79472, 50-44414, 50-79472 1, 50-893893
 Para: 2.5L, 3.4L & 135 Jet modelos



18-5610
MOTOR DE ARRANQUE
 Reemplaza: 50-66015T, 50-660151, 50-660153, 50-893892T, 50-893892T
 (8 Dientes)
 Para: 1.7L, 1.9L & 1.4L (1988-2008)



18-5611
MOTOR DE ARRANQUE
 Reemplaza: 50-90983A-1, 50-90983T1, 50-8M0033984
 Para: 6-15 HP (1986-96), 18-25 HP (1980-87), 10 dientes

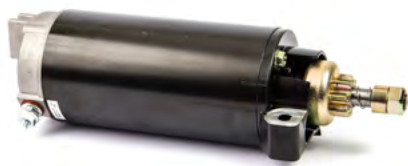

18-5620
MOTOR DE ARRANQUE
 Reemplaza: 50-818445-3, 50-818445-2, 50-818445 5, 50-898265009
 Para: 2.5L, 3.0L & 225-250 HP (1993-2000)



18-5621
MOTOR DE ARRANQUE
 Reemplaza: 50-822462, 50-822462T1, 50-893890T
 Para: 30-60 HP



18-5636
MOTOR DE ARRANQUE
 Reemplaza: 50-57465A1, 50-57867, 50-64975, 50-72467, 50-58788A3
 Longitud: 11 1/2"
 Para: 65-175 HP (1973-88)



18-6824
MOTOR DE ARRANQUE FUERABORDA
 Reemplaza: 50-60594A, A1, T01
 Para: 2.0, 2.4, y 2.5L Racing



18-6825
MOTOR DE ARRANQUE
 Reemplaza: 50-86976
 (9 dientes)
 Para: Motores 200-225HP V6



18-6828
MOTOR DE ARRANQUE
 Reemplaza: 50-41583
 Para: 35, 35 (2 Cil.), 402, 40 (2 Cil.)



18-6829
MOTOR DE ARRANQUE
 Reemplaza: 50-852570, T, 50-857065, 50-859168, T, 859168, T
 Para: Mercury, Mariner 9.9-15HP 4-tiempos



18-6864
MOTOR DE ARRANQUE
 Reemplaza: 50-819271, 50-820193A1
 Para: Mercury 40-50HP

18-55505

MOTOR DE ARRANQUE FUERABORDA

Reemplaza: 8M0142679. Para: 175-300HP; 250-300 VERADO; 250 4.6L V8 VERADO (4T)-2B529482 y sup., 300 4.6L V8 Verado (4T), SEAPRO-2B529482 y sup., 225 4.6L V8 (4T) SEAPRO-2B529482 y sup., 250 4.6L V8 (4T) SEAPRO-2B529482 y sup., 250 4.6L V8 (4T) RACING-1E080500 y sup., 300 4.6L V8 (4T) RACING-1E080500 y sup., 200 4.6L V8 PRO XS (4T) 2B529482 y sup., 225 4.6L V8 PRO XS (4T) 2B529482 y sup., 300 4.6L V8 PRO XS (4T) 2B529482 y sup., 175 3.4L V6 (4T) 2B529482 y sup., 200 3.4L V6 (4T) 2B529482 y sup., 225 3.4L V6 (4T) 2B529482 y sup., 200 3.4L V6 (4T) SEAPRO 2B529482 y sup., 175 3.4L V6 PRO XS (4T) 2B529482 y sup.



18-55506

MOTOR DE ARRANQUE FUERABORDA

Reemplaza: 8M0137769. Para: 75 EFI (4T)- 2B095049 y sup., 75 EFI (4T) SEAPRO 2B095049 y sup., 80 EFI (4T) 2B095049 y sup., 90 EFI (4T) SEAPRO 2B095049 y sup., 100EFI (4T) SEAPRO 2B095049 y sup., 115EFI(4T) 2B095049 y sup., 115EFI (4T) SEAPRO 2B095049 y sup., 65 JET (4T) 2B095049 y sup., 80 JET (4T) 2B095049 y sup., 115 PRO XS (4T) 2B225488 y sup.



18-6940

MOTOR DE ARRANQUE

Reemplaza: 50-825991A2
Para: 9.9HP 4- tiempos



18-6943

MOTOR DE ARRANQUE

Reemplaza: 50-893894
Para: 9.9-15HP



**18-6250
KIT REPARACIÓN
MOTOR DE
ARRANQUE**

Prestolite 2 Escobillas



18-6251

**KIT REPARACIÓN
MOTOR DE ARRANQUE**

Prestolite 4 Escobillas



**18-5697
KIT ESCOBIAS Y
MUELLES**

Reemplaza: 75384
Ver tabla para otras aplicaciones



**18-5656
PIÑÓN**

Reemplaza: 68575
(10 dientes)
Ver tabla para otras aplicaciones



**18-5658
PIÑÓN**

Reemplaza: 86177, 86177 1
(9 dientes)
Ver tabla para otras aplicaciones



**18-5674
PIÑÓN**

Reemplaza: 75661, 13310T1
(8 dientes)
Ver tabla para otras aplicaciones



**18-5650
PIÑÓN**

Reemplaza: 57380
Ver tabla para otras aplicaciones



MERCURY

H.P.	Desde nº de serie #	Hasta nº de serie #	O.E.M #	Motor de arranque #	O.E. #	Conjunto de Piñones	O.E. #	conjunto de Piñones	Kit Escobillas	O.E. #
6	A197112	& Sup	50-8M0033984/50-90983A1	18-5611	96562		—	10	—	—
7.5	3801458	4851692	50-73531	⑥	96562		96562/75427	10	18-5697	75384
7.5	4851693	& Sup	50-78011	⑥	96562		96562/75427	10	18-5697	75384
8/9.9/15	A197112	& Sup	50-8M0033984/50-90983A1	18-5611	96562		—	10	—	—
18	5837437	& Sup	50-8M0033984/50-90983A1	18-5611	96562		—	—	—	—
20	4709593	6443973	50-76275	⑥	96562		96562/75427	10	—	—
20	6443973	& Sup	50-8M0033984/50-90983A1	18-5611	96562		—	10	—	—
25	5705532	& Sup	50-8M0033984/50-90983A1	18-5611	96562		—	10	—	—
30 2 cil.	G053314	& Sup	50-893890T/50-822462	18-5621	N.L.A.	18-5656	68575	10	18-5697	75384
30 JET	G159200	G589999	50-898265005/50-73521	18-5605	68575 3	18-5656	68575	10	18-5697	75384
30 JET 3 cil.	G590000	T408999	50-893890T/50-822462	18-5621	90643	18-5656	68575	10	18-5697	75384
35 2 cil.	6445653	& Sup	50-41583T/50-41583	⑥	N.L.A.		43076/ 43076T	10	18-5697	75384
35/40 2 cil.	6445652	& inf	50-55601A2/50-55601	18-5601	N.L.A.	18-5650	57380	9	18-5697	75384
40 2 cil.	G053314	& Sup	50-893890T/50-822462	18-5621	68575 3	18-5656	68575	10	18-5697	75384
40H.P. 3 cil.	G590000	G760299	50-893890T/50-822462	18-5621	68575 3	18-5656	68575	10	18-5697	75384
40 3 cil.	G760300	& Sup	50-893890T/50-822462	18-5621	68575 3	18-5656	68575	10	18-5697	75384
40 4 cil.	C159200	& Sup	50-898265005/50-73521	18-5605	68575 3	18-5656	68575	10	18-5697	75384
40 JET	T178500	& Sup	50-893890T/50-822462	18-5621	68575 3	18-5656	68575	10	18-5697	75384
45 4 cil.	5531630	& Sup	50-898265005/50-73521	18-5605	68575 3	18-5656	68575	10	18-5697	75384
45 JET	D000750	G589999	50-44369A1/50-65436/50-60315	18-5606 ⑤	68575 3	18-5656	—	—	—	—
45 JET	G590000	T129554	50-893890T/50-822462	18-5621	68575 3	18-5656	68575	10	18-5697	75384
50 4 cil.	4357639	& abajo	50-55601A2/50-38890A1	18-5601	N.L.A.	18-5650	57380	9	18-5697	75384
50 4 cil.	4357640	& Sup	50-898265005/50-73521	18-5605	68575 3	18-5656	68575	10	18-5697	75384
50 3 cil.	B122930	G589999	50-44369A1	18-5606 ⑤	68575 3	18-5656	—	—	—	—
50 3 cil.	G590000	& Sup	50-893890T/50-822462	18-5621	68575 3	18-5656	68575	10	18-5697	75384
55 3 cil.	D000750	G589999	50-44369A1	18-5606 ⑤	68575 3	18-5656	—	—	—	—
55 3 cil.	G590000	& Sup	50-893890T/50-822462	18-5621	68575 3	18-5656	68575	10	18-5697	75384
60 3 cil.	6428681	G589999	50-44369A1/50-65436/50-60315	18-5606 ⑤	68575 3	18-5656	—	—	—	—
60 3 cil.	G590000	& Sup	50-893890T/50-822462	18-5621	68575 3	18-5656	68575	10	18-5697	75384
60 3 cil. Bigfoot	G590000	G760299	50-893890T/50-822462T 1	18-5621	68575 3	18-5656	68575	10	18-5697	75384

Nota: Algunos starters se adaptan a versiones de prestolite en principio sólo son para versiones Bosh.
② 6 Cilindros en línea

④ Con piñones 8 dientes
⑤ Con piñones 9 dientes
⑥ No hay recambio del starter, sólo piezas

⑦ Sólo modelos Bosh
⑧ Algunas aplicaciones requieren adaptador Mercury #44368 (anterior a S/N 0D000750)

MERCURY

H.P.	Desde n° de serie #	Hasta n° de serie #	O.E.M #	Motor de arranque #	O.E. #	Conjunto de Piñones	O.E. #	N° De Dientes	Kit Escobillas	O.E. #
65 4 cil.	2803822	3293183	50-57867A1/50-58788	18-5636	68575 3	18-5656	68575	10	18-5697	75384
65 3 cil.	3293184	4571651	50-44369A1/50-65436/50-60315	18-5606	68575 3	18-5656				
65 Jet	D283222	& Sup	50-893891T/50-66015	18-5642	68575 3	18-5656	68575	10	18-5697	75384
70 3 cil.	457165	A996142	50-44369A1/50-65436/50-60315	18-5606	68575	18-5656				
80 4 cil.	2783253	3493912	50-57867A1/50-58788	18-5636	N.L.A.		68575	10	18-5697	75384
80 4 cil.	4831999	& Sup	50-893891T/50-66015	18-5642	68575 3	18-5656	68575	10	18-5697	75384
85 4 cil.	3865694	& Inferior	50-58788A3/50-58788	18-5636	N.L.A.	18-5656	68575	10	18-5697	75384
85 4 cil.	3865695	4366801	50-67341	18-5602	68575 3	18-5656	68575	10	18-5697	75384
80 Jet	D283222	& Sup	50-893892T/50-66015-1	18-5610	68575 3	18-5656	75660/13310T1	8	18-5697	75384
90	4845301	& Sup	50-72467/50-64975/50-57465A1	18-5636	68575 3	18-5656	68575	10	18-5697	75384
90 3 cil.	A996142	& Sup	50-893891T/50-66015	18-5642	68575 3	18-5656	68575	10	18-5697	75384
100 4 cil.	B209468	G965520	50-893892T/50-66015-1	18-5610	68575-3	18-5674	75660/13310T1	8	18-5697	75384
105 JET	G760299	& Inferior	50-893893/50-44414/50-44415/50-79472/50-77141	18-5608	13310T 1	18-5674	75660/13310T1	8	18-5697	75384
115 6 cil.	4855153	& Sup	50-72467/50-64975/50-57465A1	18-5636	68575 3	18-5656	68575	10	18-5697	75384
115 4 cil.	C100000	& Sup	50-893892T/50-66015-1	18-5610	68575 3	18-5674	75660/13310T1	8	18-5697	7538
125 4 cil.	D283222	& Sup	50-893892T/50-66015-1	18-5610	68575 3	18-5674	75660/13310T1	8	18-5697	75384
135 V-6	A904646	G960499	50-893893/50-79472/50-77141/50-44414/50-44415	18-5608	13310T 1	18-5674	75660/13310T1	8	18-5697	75384
140 6 cil. en línea	4865678	& Sup	50-72467/50-64975/50-57465A1	18-5636	68575 3	18-5656	68575	10	18-5697	75384
140 JET	G960499	& Inferior	50-893893/50-44414/50-44415/50-79472/50-77141	18-5608	1310T 1	18-5674	75660/13310T1	8	18-5697	75384
150	4121435	& Sup	50-72467/50-64975/50-57465A1	18-5636	68575 3	18-5656	68575	10	18-5697	75384
V150	4868998	G960499	50-793793/50-79472/50-77141	18-5608	13310T 1	18-5674	75660/13310T1	8	18-5697	75384
150 XR2	4868998	A904645	50-44414,50-44415	18-5608	N.L.A.	18-5674	75660/13310T1	8	18-5697	75384
150 XR4	B242885	D819999	50-893893/50-79472/50-77141/50-44414/50-44415	18-5608	13310T 1	18-5674	75660/13310T1	8	18-5697	75384
150 XR6	D082000	G960499	50-893893/50-79472/50-77141/50-44414/50-44415	18-5608	13310T 1	18-5674	75660/13310T1	8	18-5697	75384
150 EFI	G303046	T408999	50-893893/50-79472/50-77141/50-44414/50-44415	18-5608	13310T 1	18-5674	75660/13310T1	8	18-5697	75384
V175	4301235	G960499	50-893893/50-79472/50-77141	18-5608	13310T 1	18-5674	75660/13310T1	8	18-5697	75384
175 EFI, XRI, MAG	D000750	G960499	50-893893/50-44414/50-44415	18-5608	N.L.A.	18-5674	75660/13310T1	8	18-5697	75384
200	4839034	G960499	50-893893/50-79472/50-77141	18-5608	13310T 1	18-5674	75660/13310T1	8	18-5697	75384
200 EFI, XRI	C100861	G960499	50-893893/50-44414/50-44415	18-5608	N.L.A.	18-5674	75660/13310T1	8	18-5697	75384
2.4EFI/2.5EFI	Todos	—	50-893893/50-79472/50-77141/50-44414/50-44415	18-5608	13310T 1	18-5674	75660/13310T1	8	18-5697	75384
2.5 Carb/	Todos	—	50-893893/50-79472/50-77141/50-44414/50-44415	18-5608	13310T 1	18-5674	75660/13310T1	8	18-5697	75384
3.4L/MOD VP	todos	—	50-893893/50-79472/50-77141/50-44414/50-44415	18-5608	13310T 1	18-5674	75660/13310T1	8	18-5697	75384
V200	5363918	6435503	50-86976	18-5609	8677 1	18-5658	86177/86177 1	9	18-5697	75384
V225	5628028	D280812	50-86976	18-5609	8677 1	18-5658	86177/86177 1	9	18-5697	75384
225 3.0L Carb	D280813	T408999	50-898265009/50-818445-3/50-818445-2	18-5620	13310T 1	18-5674	75661/13310T1	8	18-5697	75384
225/250 EFI 3.0L	G129222	& Sup	50-898265009/50-818445-3/50-818445-2	18-5620	13310T 1	18-5674	75661/13310T1	8	18-5697	75384
250XB	G980600	& Sup	50-898265009/50-818445-3/50-818445-2	18-5620	13310T 1	18-5674	75661/13310T1	8	18-5697	75384

Nota: Algunos starters se adaptan a versiones de prestolite en principio sólo son para versiones Bosh.

- ② 6 Cilindros en línea
- ④ Con piñones 8 dientes
- ⑤ Con piñones 9 dientes

⑥ No hay recambio del starter, sólo piezas

- ⑦ Sólo modelos Bosh
- ⑧ Algunas aplicaciones requieren adaptador Mercury #44368 (anterior a S/N 0D000750)

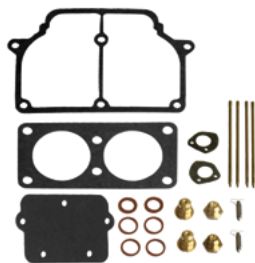

18-7354
KIT CARBURADOR
Reemplaza:
1395-8506
V-175 Fuerabordas
Número de serie 4301235 hasta OC100860



18-7355
KIT CARBURADOR
Reemplaza: 1395-811691 2

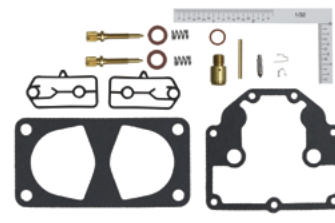

18-7356
KIT CARBURADOR
Reemplaza: 1395-811691 3



18-7004
KIT CARBURADOR
Reemplaza: 1395-6200



18-7005
KIT CARBURADOR
Reemplaza: 1395-6452



18-7006-1
KIT CARBURADOR
Reemplaza: 1399-1717,
1399-2015, 1399-3523, 1395-4808,
1395-8791994024, 879194024



18-7007
KIT CARBURADOR
Reemplaza: 1399-5135,
1399-5198



18-7013
KIT CARBURADOR
Para: AJ, KA, KB, KC, KD Carburador



18-7021
KIT CARBURADOR
Para: WM, WMK

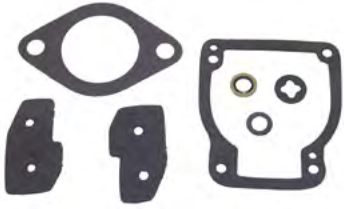

18-7211-1
KIT CARBURADOR
Reemplaza: 1395-8112231



18-7212
KIT CARBURADOR
Reemplaza: 1395-97611, 1395-9761, 1395-9803,
1395-9725, 1395-9645, 1395-9377, 1395-9179,
1395-811357

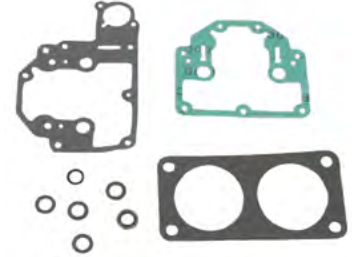

18-7213
KIT CARBURADOR
Reemplaza: 8107492

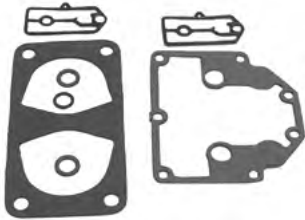

18-7214
KIT CARBURADOR
Reemplaza: 8107493



18-7215
KIT CARBURADOR
Reemplaza: 1395-9024

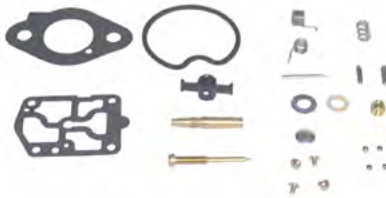

18-7226
KIT CARBURADOR
Reemplaza: 1395-9650
Para: 30 JET, 40/45 4 Cil 4 Tiempos,
Carb modelos WMA-7B,9,10,13



18-7290
KIT CARBURADOR
Reemplaza: 84419M

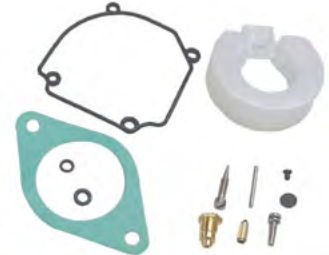

18-7291
KIT CARBURADOR
Reemplaza: 84475M



18-7293
KIT CARBURADOR
Reemplaza: 92520M



18-7738
KIT CARBURADOR
Reemplaza: 802706A1
Para: 9.9 4 Tiempos (323cc) (1999 & sup)
y 15.4 tiempos (1998 & sup)



18-7743
KIT CARBURADOR
Reemplaza: 804346T1
Para: 75 4 Tiempos (2000 & sup), 90 4 tiempos (2000 & sup)



**18-7750-1
KIT CARBURADOR**
Reemplaza: 1395-8236354,
1395-8236353, 1395-8236352,
1395-8236351, 1395-823635,
1395-811222, 1395-9599
Para: WME-1,1A,1B,4,5,6,6A,7,
7B,8,9,10,10A,11,14,15,15A,17,
18,20,20A,21,21A,22,22B,23,2
4,26,27,28,32,32A,33,34,35,36,
36A,37,37A,38,39A,40,40A,42,4
2A,43,44,45,50,52,53,57,58,63,
64,65,66,67,68,69,79,81



**18-7765
KIT CARBURADOR**
Reemplaza: 11502M



**18-7769
KIT CARBURADOR**
Reemplaza: 814481M



**18-7770
KIT CARBURADOR**
Reemplaza: 84456M



**18-34500
CARBURADOR**
Reemplaza: 3303-
895110T01
Para: 9.9 Handle (4-Tiempos)
(R042475-R068397)



**18-7062
AGUJA**
Reemplaza: 1395-95951
Para: WME-
1,1A,1B,4,5,6,6A,7,
7B,8,9,10,10A,11,14,15,15A,17,
18,20,20A,21,21A,22,22B,23,
24,26,27,28,32,32A,33,34,35,
36,36A,37,37A,38,39A,40,40A,
42,42A,43,44,45,50,52,53,57,
58,63,64,65,66,67,68,69,79,81



**18-7057
AGUJA Y ASIENTO**
Reemplaza: 1399-1473,
1395-9258, 1399-1138,
1399-9258 1
.078



**18-0715
JUNTA CAMARA**
Reemplaza: 809086, 25-809086



**18-7061
AGUJA Y ASIENTO**
Reemplaza: 1395-8318,
1395-83181
.065



**18-7295
VÁLVULA DE AGUJA**
Reemplaza: 1395-9022



**18-7233
AGUJA Y ASIENTO**
Reemplaza: 1395-7824



**18-36850
AGUJA Y ASIENTO**
Reemplaza: 1395-8116901
Para: Mercruiser 2.5 & 3.0L Carbs



**18-7380
FLOTADOR**
Reemplaza: 809569
15 (4-tiemp.) todos, 50 (4-tiemp.)



**18-7381
FLOTADOR**
Reemplaza: 16253
4 (SN A855097 & sup),
5 (SN A855097 & sup)



**18-7382
FLOTADOR**
Reemplaza: 804184
75 (4-tiempos) todos,
90 (4-tiempos) todos



**18-7208
FLOTADOR**
Reemplaza: 1395-8983,
1395-8673



**18-72000
FLOTADOR**
Reemplaza: 1395-9594
Para: WME1,1A,1B,4,5,6,6A,7,
7B,8,9,10,10A,11,14,15,15A,
17,18,20,20A,21,21A,22,22B,
23,24,26,27,28,32,32A,33,34,
35,36,36A,37,37A,38,39A,40,
40A,42,42A,43,44,45,50,
52,53,57,58,63,64,65,66,67,
68,69,79,81



**18-7249
KIT FLOTADOR**
Reemplaza: 19273
Para: WM-3,5,6,8,9,10,11,12,13,
13A,14,15,15A,16,16A,17,18



**18-7209
FLOTADOR**
Reemplaza: 1395-9293



**18-36956
FLOTADOR**
Reemplaza: 1395-9267
Para: Mercury V6 con carb. dual

APLICACIÓN KIT CARBURADOR MARINER

HP	Año/N° de serie	Modelo carb.	HP	Año/N° de serie	kit carb.	HP	Año/N° de serie	kit carb.
6 C-D	Ser.No.Code 6H8 & 6H6	18-7765	25A	M-648-24991 & Sup ML-648-64046 & Sup E-648-27056 & Sup EL-648-56526-& Sup	18-7770	30A	M-689-230100 & Sup ML-689-530100 & Sup E-689-250100 & Sup EL-689-550100 & Sup	18-7770
8C	Ser.No.Code 6G1	18-7765						
9.9C	M-682-070796 & Sup ML-682-368040 & Sup E-682-251511 & Sup EL-682-55146 & Sup	18-7769	25C	Ser.No.Code 695	18-7770	48	M-670-02641 & Sup ML-670-34581 & Sup	18-7290
			28	M-664-05306 & Sup ML-664-41686 & Sup E-664-26236 & Sup EL-664-57421 & Sup	18-7770	W48	Ser.No.Code 670	18-7290
15C	M-684-052848 & Sup ML-684-332302 & Sup E-684-252381 & Sup EL-684-553251 & Sup	18-7769			18-7770	55	Ser.No.Code 663	18-7290
						W55	Ser.No.Code 663	18-7290
						60	Ser.No.Code 675	18-7290

APLICACION KIT CARBURADOR MERCURY

HP	Año/N° de serie	Modelo carburador	kit carburador	Kit de juntas	Aguja y asiento	Flotador	
3.9	1964-68	KB-7A,KB-7B	18-7013	18-7006-1	18-7057	18-7208	
4 (1 cil.)	1969-74, 80-81,86-87	KB-10A	18-7013	18-7006-1	18-7057	18-7208	
		WMD-1	—	18-7006-1	18-7061	18-7208	
4 (1 cil.)	1980-85	KD-10A	18-7013	18-7006-1	18-7057	18-7208	
4.5	1980-85	WMD-1	18-7021	18-7006-1	18-7061	18-7208	
6	1961-68	KB-6A,6B,7B,AJ57A	18-7013	18-7006-1	18-7057	18-7208	
6	S/N A197112-Sup	WMC-5,5A,5B,7,7A, 17,17B,17C,18,18A, 18B,19,19A,20,20A, 20B,23,28,34, 39,41,47,49	—	—	—	—	
		KB-9A,KB-12A	18-7013	18-7006-1	18-7212	—	
			—	—	—	—	—
			—	—	—	—	—
7.5	1969-73	KB-9A,KB-12A	18-7013	18-7006-1	18-7057	18-7208	

APLICACIONES CONTINÚAN EN LA SIGUIENTE PÁGINA

APLICACIÓN KIT CARBURADOR MERCURY (Cont)

HP	Año/N° de serie	Modelo carburador	Kit carburador	kit de juntas	Aguja y asiento	Flotador
7.5	1972-85	BB-2A, BB-2B, BB-2C, BB-4A, BB-5A, BB-5B, BB5C, BB-5D, BB-7A, BB-7C	—	—	—	—
7.5		WMB-2, 4	—	18-7007	18-7295	18-7209
8	S/N A197112-Sup	WMC-5,5A,5B,7,7A, 17, 17B, 17C, 18, 18A, 18B, 19, 19A, 20, 20A, 20B, 23, 28, 34, 39, 41, 47, 49, 57	—	—	18-7295	18-7209
9.8	1962-73	KB-5A, 8A, 11A	18-7013	18-7006-1	18-7057	18-7208
9.8	1972-85	BB-1B, BB-1C, BB-3A, BB-3B, BB-3C, BB-6A, BB-6C	—	—	—	—
9.8		WMB-1, 3	—	—	18-7295	18-7209
9.9 (2 tiempos)	S/N A197112-Sup	WMC-5,5A,5B,7,7A,17, 17B, 17C, 18, 18A, 18B, 19, 19A, 20, 20A, 20B	—	18-7212	—	—
9.9 (2 tiempos)		WMC-23, 28, 34, 39, 41, 41A, 47, 47A, 49, 49A, 57	—	18-7212	—	—
9.9 (4 tiempos) (4 tiempos)	S/N OG590000-Sup	—	—	—	—	—
(323cc)		—	18-7738	—	—	—
10	1957-61	AJ-52A	18-7013	18-7006-1	18-7057	18-7208
10		AJ-56AB	—	18-7006-1	18-7057	18-7208
10		KB-1A, 4A	—	18-7006-1	18-7057	18-7208
10 Seapro/ Marathon	Todos	WMC-33, 33A, 40, 42, 50, 50A, 55, 55A	—	—	—	—
XR-10	Todos	WMC-23, 48, 48A, 49, 49A	—	18-7212	—	—
MAG 10	Todos	WMC-23, 48, 48A, 49, 49A	—	18-7212	—	—
15	1959-61	AJ-52A, AJ-56A	18-7013	18-7006-1	18-7057	18-7208
15(150)		KB-1A, 4A	—	18-7006-1	18-7057	18-7208
15	S/N A197112-Sup	WMC-5,5A,5B,7,7A,17, 17B, 17C, 18, 18A, 18B, 19, 19A, 20, 20A, 20B	—	18-7212	—	—
15		WMC-23, 28, 34, 39, 41, 41A, 47, 47A, 49, 49A, 57	—	18-7212	—	—
15	S/N OG590000-Sup	—	18-7738	—	—	—
15 Seapro/ Marathon	Todos	WMC-33, 33A, 40, 42, 50, 50A, 55, 55A	—	18-7212	—	—
Super 15	S/N 6443973-Sup	WMC-1, 2, 3, 4, 9, 10, 11, 12, 13, 13A, 14, 14A, 15A, 16A, 24, 25, 26, 27, 29, 30, 31, 31A, 32, 32A, 35, 35A, 35B, 36, 37, 44, 45, 46, 46A, 50, 53, 54, 56	—	—	—	—
Seapro/ Marathon	S/N 6443973-Sup	WMC-1, 2, 3, 4, 9, 10, 11, 12, 13, 13A, 14, 14A, 15A, 16A, 24, 25, 26, 27, 29, 30, 31, 31A, 32, 32A, 35, 35A, 35B, 36, 37, 44, 45, 46, 46A, 50, 53, 54, 56	—	—	—	—
15XD/25		WMC-1, 2, 3, 4, 9, 10, 11, 12, 13, 13A, 14, 14A, 15A, 16A, 24, 25, 26, 27, 29, 30, 31, 31A, 32, 32A, 35, 35A, 35B, 36, 37, 44, 45, 46, 46A, 50, 53, 54, 56	—	18-7212	—	—
15 (4-Tiempos)	S/N OG590000-Sup	—	18-7738	—	—	—
18	S/N 6443973-Sup	WMC-1, 2, 3, 4, 9, 10, 11, 12	—	—	18-7212	—
18		WMC-13, 13A, 14, 14A, 15A, 16A, 24, 25, 26, 27, 29, 30, 31, 31A	—	18-7212	—	—
20	S/N 6443973-Sup	WMC-1, 2, 3, 4, 9, 10, 11, 12	—	—	—	—
20		WMC-13, 13A, 14, 14A, 15A, 16A, 24, 25, 26, 27, 29, 30, 31, 31A	—	18-7212	—	—
20 (200)	1963-72	KA-20A, 22A, 22B, 22C, 23A, 25A	18-7013	18-7006-1	18-7057	18-7208
20	1973-80	BA-1A, BA-2A, BA-2C, BA-2D, BA-2E	—	18-7007	—	18-7209
Jet 20	S/N 6443973-Sup	WMC-1, 2, 3, 4, 9, 10, 11, 12, 13, 13A, 14, 14A, 15A, 16A, 24, 25, 26, 27, 29, 30, 31, 31A, 32, 32A, 35, 35A, 35B, 36, 37, 44, 45, 46, 46A, 50, 53, 54, 56	—	—	—	—
22	1958-59	KA-KC	18-7013	18-7006-1	18-7057	18-7208
25 (2 cil)	S/N 6443973-Sup	WMC-1, 2, 3, 4, 9, 10, 11, 12	—	18-7212	—	—
25 (2 cil)		WMC-13, 13A, 14, 14A, 15A, 16A, 24, 25, 26, 27, 29, 30, 31, 31A, 32, 32A, 35, 35A, 35B, 36, 37, 44, 45, 46, 46A, 50, 53, 54, 56	—	18-7212	—	—
30 (2 cil.)(644cc)	S/N G053314-Sup	WME-36, 36A, 37, 37A, 38, 39A, 42, 42A, 63, 64, 65, 66, 67	—	—	—	—
30 (300) 4-cil		AJ-54A	18-7750-1	18-7211-1	—	18-72000
30 (300) 4-cil		KB-2A	—	—	18-7057	18-7208
30 JET (3 cil)		WME-53, 68, 69	18-7750-1	18-7211-1	18-7057	18-7208
30 JET (4 cil)		WMA-10, 13	18-7226	—	—	—
35	1984-89	KC-4A, 8A, 9A, 9B, 9C, 13A	18-7013	18-7006-1	18-7061	18-7208
35	1963-69	KB-2A	18-7013	18-7006-1	18-7057	18-7208
35	1984-89	WMK-38	18-7021	18-7006-1	18-7061	18-7208

APLICACIONES CONTINUAN EN LA SIGUIENTE PÁGINA

APLICACIÓN KIT CARBURADOR MERCURY (Cont)





















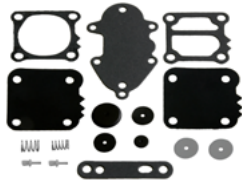

HP	Año/Nº de serie	Modelo carburador	Kit carburador	Kit de juntas	Aguja y asiento	Flotador
35		AJ-54A	—	—	18-7057	18-7208
40	1960-61	KA-7A,KD-5A, KA-2A,KA-9A	—	—	—	—
40	1954-59	AJ	18-7013	18-7006-1	18-7057	18-7208
40	1970-74	WMK-1,WMK-8	18-7021	18-7006-1	18-7061	18-7208
40	1975-83	WMK-21,WMK-24, WMK-31	—	—	—	—
40 (2 cil.)	S/N G053314-Sup	WME-36,36A37,37A, 38,39A,42,42A,63, 64,65,66,67	—	—	—	—
40 (3 cil.)		WME-53, 68, 69	18-7750-1	18-7211-1	—	18-72000
40 (4 cil.)		WMA-4	—	18-7215	18-7295	18-7209
40 (4 cil.)		WMA-7B	18-7226	—	—	18-7209
40 (4 cil.)		WMA-9, 10, 13	18-7226	—	—	—
45	1958-62	KA-2A	18-7013	18-7006-1	18-7057	18-7208
45	1958-62	AJ-54A	18-7013	18-7006-1	18-7057	18-7208
45 (4 cil.)	1986	Tillotson/Walbro	—	18-7007	—	18-7209
45 (4 cil.)	1987-Sup	WMA-4	—	18-7215	18-7295	18-7209
45 (4 cil.)		KA-17A	18-7013	—	18-7057	18-7208
45 (4 cil.)		WMA-7B	18-7226	—	—	18-7208
45 (4 cil.)		WMA-9, 10, 13	18-7226	—	—	—
45 JET (3 cil.)		WME-57, 58	18-7750-1	18-7211-1	—	18-72000
50 (4 cil.)	1961-75	KA-13A,18A,19A, 21A,21B,21C,21D, 24A,26A,26B,27A	—	—	—	—
50	1976-85	BA-3B,BA-3C,BA-3D	18-7013	18-7006-1	18-7057	18-7208
50 (3 cil.)	1986-90	WM-13, 13A, 15, 15A, 16, 16A, 18	—	18-7004	—	18-7249
50 (3 cil.)		WME-22,22B,23,24,26, 27, 28, 35, 43, 44, 45, 53, 68, 69	18-7750-1	18-7211-1	—	18-72000
50 (4cil.)	1986-Sup	WMA-1,3	—	18-7215	18-7295	18-7209
50 (4cil.)		BA-3A, 3B, 3C, 3D, 4A	—	18-7007	18-7295	18-7209
50 (4cil.)		WMK-8	18-7021	18-7006-1	18-7061	18-7208
55 (3 cil.)		WM-13, 13A, 15, 15A, 16, 16A, 18	18-7249	18-7004	—	—
55		WME-22, 22B, 23, 24, 26, 27, 28, 35, 43, 44, 45, 57, 58	18-7750-1	18-7211-1	—	18-72000
60 (3 cil.)	S/N D000750-Sup	WME-22,22B,23,24,26, 27, 28, 35, 43, 44, 45, 57, 58	18-7750-1	18-7211-1	—	18-72000
60 (3 cil.)	1984-90	WM-13,13A, 15, 15A, 16, 16A, 18	—	18-7004	—	18-7249
60	1957-60	AJ-53A,AJ-55A,KB	18-7013	18-7006-1	18-7057	18-7208
60 600 (6 cil.)		KB-3A	—	18-7006-1	18-7057	18-7208
65 650 (4 cil.)	1963-71	KC-2A,5A,5B,5C, 11A,15A	18-7013	18-7006-1	18-7057	18-7208
65 650 (3 cil.)	1972-75	WMK-5,WMK-12, WMK-13,WMK-20	18-7021	18-7006-1	18-7061	18-7208
65	1976	WM-2,WM-4	—	18-7004	18-7061	18-7208
Jet 65 (3 cil.)	S/N A996142-Sup	WME-1,1A,1B,4,5,6,6A, 7, 7B, 8, 9, 10, 10A, 15, 15A, 17, 18, 19, 25, 29, 30, 31, 41, 46, 47, 48, 49, 59, 60, 61, 62, 75, 76, 77	18-7750-1	18-7211-1	—	18-72000
70	1958-62	KC,KA-2A	18-7013	18-7006-1	18-7057	18-7208
70 700 (6 cil.)		KA-8A, 12A	18-7013	18-7006-1	18-7057	18-7208
70	1977-83	WM-6,8, 9, 11	—	18-7004	18-7061	18-7249
70 (3 cil.)	S/N A996142-Sup	WME-1,1A,1B,4,5, 6,6A,7,7B,8,9,10, 10A,15,15A,17,18, 19,25,29,30,31,41, 46,47,48,49,59, 60,61,62	—	—	—	—
75 (4 cil.)	1984-86	WM-14, 17	18-7750-1	18-7211-1	—	18-72000
75 (3 cil.)	S/N A996142-Sup	WME-1,1A,1B,4,5, 6,6A,7,7B,8,9,10, 10A,15,15A,17,18, 19, 25,29,30,31,41, 46,47,48,49,59, 60,61,62	18-7750-1	18-7211-1	—	18-72000
75 (4 tiempos)	S/N OG960500-Sup	—	18-7743	—	—	—
80 (3 cil.)	S/N A996142-Sup	WME-1,1A,1B,4,5, 6,6A,7,7B,8,9,10, 10A,15,15A,17,18, 19,25,29,30,31,41, 46,47,48,49,59, 60,61,62	—	—	—	—
80 (4 cil.)	1960-61	KD-4A	18-7013	18-7006-1	18-7061	18-7208
80 (4 cil.)	1969-72	WMK-2	18-7021	18-7006-1	18-7061	18-7208
80 (4 cil.)	1978-83	WM-5,10,12, 14, 17	—	18-7004	18-7061	18-7249
80 800 (6 cil.)		KA-10A, 11A, 14A, 16A, KC-3A	—	18-7006-1	18-7057	18-7208
Jet 80 (4 cil.)	S/N B209468-Sup	WME-11,14,20,20A, 21,21A,32,32A,33, 34,40,40A,50,51,52,79	18-7750-1	18-7211-1	—	18-72000
85	1973-75	WMK-4,WMK-16, WMK-17	18-7021	18-7006-1	18-7061	18-7208
85 850 (6 cil.)	1963-65	KA,KC	18-7013	18-7006-1	18-7057	18-7208
85	1976-77	WM-3,WM-5	—	18-7004	18-7061	18-7249
90 (3 cil.)	S/N A996142-Sup	WME-1,1A,1B,4,5,6, 6A,7,7B,8,9,10,10A, 15,15A,17,18,19,25, 29,30,31,41,46,47, 48,49,59,60,61,62	—	—	—	—
90 (4 tiempos)	S/N OG960500-Sup	—	18-7750-1	18-7211-1	—	18-72000
90 (6 cil.)	1965	KC-6A	18-7013	18-7006-1	18-7057	18-7208
90 (6 cil.)	1978-86	WMK-23,WMK-27, WMK-30,WMK-35, WMK-39	—	—	—	—
95	1966-67	KC-6A	18-7021	18-7006-1	18-7061	18-7208
100 (4 cil.)	S/N B209468-Sup	WME-11,14,20,20A, 21,21A,32,32A,33,34	—	—	—	—

APLICACIONES CONTINUAN EN LA SIGUIENTE PÁGINA

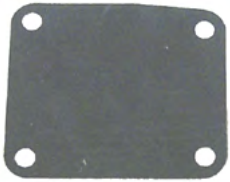
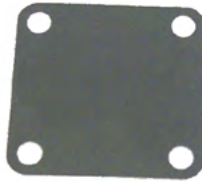
APLICACIÓN KIT CARBURADOR MERCURY (Cont.)

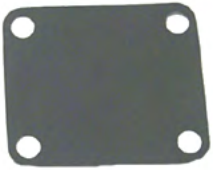
HP	Año/N° de serie	Modelo Carburador	kit carburador	Kit de juntas	Aguja y asiento	Flotador
100 (6 cil.)	1962-69	40,40A,50,51,52,79	18-7750-1	18-7211-1	—	18-72000
100 (6 cil.)		KC-1A,7A,10A,14A	18-7013	18-7006-1	18-7057	18-7208
V-105 Jet	1994-95 S/N OD082000-OG303045	KD-1A, 1B, 2A, 3A	18-7013	18-7006-1	18-7061	18-7208
V-105 Jet	1996 & Sup S/N OG303046 & Sup	WMH-13, 13B, 23, 31	18-7355	18-7213	—	—
110		WMV-2, 2A	18-7356	18-7214	—	—
115 (4 cil.)	S/N B209468-Sup	KC-1A, 7A, 7B, 10A, 14A	18-7013	18-7006-1	18-7057	18-7208
		WME-11,14,20,20A,	—	—	—	—
		21,21A,32,32A,33,34,	—	—	—	—
		40,40A,50,51,52	18-7750-1	18-7211-1	—	18-72000
115 (6 cil.)	1970-77	KD-6A,KD-6B	18-7013	18-7006-1	18-7061	18-7208
115 (6 cil.)	1970-88	WMK-3,10,15, 18, 26, 28, 32, 36 , 40, 41, 41-1A, 41-1B, 41-3A, 41-3B	18-7021	18-7006-1	18-7061	18-7208
125	1968-69	KD-1A,1B,2A, 3A	18-7013	18-7006-1	18-7057	18-7208
125 (4 cil.)	S/N B209468-Sup	WME-11,14,20,20A,	—	—	—	—
		21,21A,32, 32A,33,	—	—	—	—
		34,40,40A,50,51,52, 81	18-7750-1	18-7211-1	—	18-72000
135	1970-71	KD-7A,KD-7B	18-7013	18-7006-1	18-7057	18-7208
135	1970-71	WMK-4	18-7021	18-7006-1	18-7061	18-7208
V-135	1986-88 S/N OA904646-OC100860	WH-33, 40	18-7354	18-7005	18-7233	—
V-135	1986-88 S/N OA904646-OC100860	WH-32, 35, 38	18-7354	18-7005	—	—
V-135	1989-90 S/N OC100861-OC239552	WH-35, 38	—	18-7005	18-7233	—
V-135	1989-90 S/N OC100861-OC239552	WH-40, 48	18-7354	18-7005	18-7233	—
V-135	1991 S/N OC239553-OD081999	WMH-8, 8A	18-7355	18-7213	—	—
V-135	1992-95 S/N OD082000-OG303045	WMH-12A, 12B, 28, 30	18-7355	18-7213	—	—
V-135	1996-98 S/N OG303046-OG760299	WMV-1, 1A	18-7356	18-7214	—	—
V-135	1999 & Sup S/N OG760300 & Sup	WMV-1A, 15, 15A	18-7356	18-7214	—	—
140	1972	WMK-7,WMK-9	18-7021	18-7006-1	18-7061	18-7208
140	1978-80	WMK-25,WMK-29	18-7021	18-7006-1	18-7061	18-7208
V-140 Jet	1994-95 S/N OG082000-OG303045	WMH-16, 21, 34, 39	18-7355	18-7213	—	—
V-140 Jet	1996-98 S/N OG303046-OG760299	WMV-5, 5A	18-7356	18-7214	—	—
V-140 Jet	1999 & Sup S/N OG760300 & Sup	WMV-5A	18-7356	18-7214	—	—
150	1973-77	WMK-11	18-7021	18-7006-1	18-7061	18-7208
150	1973-78	WMK-14,WMK-19,	—	—	—	—
		WMK-22	18-7021	18-7006-1	18-7061	18-7208
3.4L	1984-86	WO-3	—	—	18-7233	—
V150	1978-90	WH-2,12,21,23,27, 29,35,38,40,48	—	18-7005	18-7233	—
V-150	1979-85 S/N OA904645 & inferior	WH-9	—	18-7005	—	—
V-150	1979-85 S/N OA904645 & inferior	WH-12	—	18-7005	18-7233	—
V-150	1979-85 S/N OA904645 & inferior	WH-29	18-7354	18-7005	18-7233	—
V-150	1986-90 S/N OA904646-OC239552	WH-35, 38	—	18-7005	18-7233	—
V-150	1986-90 S/N OA904646-OC239552	WH-40, 48	18-7354	18-7005	18-7233	—
V-150	1990-91 S/N OC239553-OD081999	WMH-1, 7	18-7355	18-7213	—	—
V-150	1992-95 S/N OD082000-OG303045	WMH-13, 13B, 23, 31	18-7355	18-7213	—	—
V-150	1996-98 S/N OG303046-OG760299	WMV-2, 2A	18-7356	18-7214	—	—
V-150	1999 & Sup S/N OG760300 & Sup	WMV-3A, 16, 16A	18-7356	18-7214	—	—
V-150 (XR4, MAGII)	1988 S/N OB242885-OC100860	WH-41A	18-7354	18-7005	18-7233	—
V-150 (XR4, MAGII)	1989 S/N OC100861-OC239552	WH-41	18-7354	18-7005	18-7233	—
V-150 (XR4, MAGII)	1989 S/N OC100861-OC239552	WH-41A	18-7354	18-7005	18-7233	—
V-150 (XR4, MAGII)	1990-91 S/N OC239553-OD081999	WMH-6	18-7355	18-7213	—	—
V-150 (XR6, MAGIII)	1996-98 S/N OG303046-OG760299	WMV-3, 3A	18-7356	18-7214	—	—
V-150 (XR6, MAGIII)	1999 & Sup S/N OG760300 & Sup	WMV-3A, 16, 16A	18-7356	18-7214	—	—
V-150 (XR6, MAGIII)	1992-95 S/N OD082000-OG303045	WMH-14A, 25, 32A	18-7355	18-7213	—	—
V-175	1976-88 S/N 4301235-OC100860	WH-1, 4, 7, 7A, 13, 17, 28, 39, 46	—	18-7005	18-7233	—
V-175	1976-88 S/N 4301235-OC100860	WH-17R, 30, 34	18-7354	18-7005	18-7233	—
V-175	1990 S/N OC100861-OC239552	WH-34	18-7354	18-7005	18-7233	—
V-175	1991 S/N OC239553-OD081999	WMH-2, 11	18-7355	18-7213	—	—
V-175	1992-95 S/N OD082000-OG303045	WMH-15, 22, 33	18-7355	18-7213	—	—
V-175	1996-98 S/N OG303046-OG760299	WMV-4, 4A	18-7356	18-7214	—	—
V-175	1999 & Sup S/N OG760300 & Sup	WMV-4A	18-7356	18-7214	—	—
V200	1978-90	WH-3,14,18,20, 22,26,28,31,39,46	—	18-7005	18-7233	—
V-200	1991 S/N OC291520-OD081999	WMH-3	18-7355	18-7213	—	—
V-200	1992-95 S/N OD082000-OG303045	WMH-16, 21, 34, 39	18-7355	18-7213	—	—
V-200	1996-98 S/N OG303046-OG760299	WMV-5, 5A	18-7356	18-7214	—	—
V-200	1999 & Sup S/N OG760300 & Sup	WMV-5A	18-7356	18-7214	—	—
V200	1980-82 S/N 4839034-OC100860	WH-3A,11	—	18-7005	—	—
V-225 (2.4L)	1981 & Sup 5628028 & Sup	WH-5, 20	—	18-7005	18-7233	—
225	S/N D280813 thru G303045	WMH-19,45,46,47	18-7355	18-7213	—	—
V225	1980-81	WH-15	—	18-7005	18-7233	—
V-225 (3.0L)	S/N OD280813-OG303045	WMH-19, 46, 47	18-7355	18-7213	—	—
V-225 (3.0L)	S/N OG303046-OG760299	WMV-7, 13	18-7356	18-7214	—	—
V-225 (3.0L)	S/N OG303046 & Sup	WMV-13, 13A	18-7356	18-7214	—	—
V-225 (3.0L)	S/N OG245605-OG303045	WMH-45	18-7355	18-7213	—	—
Seapro/Marathon						
V-225 (3.0L)	S/N OG303046-OG760299	WMH-6, 11A	18-7356	18-7214	—	—
Seapro/Marathon						
V-225 (3.0L)	S/N todos & Sup	WMV-11, 11A, 13, 13A, 19	18-7356	18-7214	—	—
Seapro/Marathon						
V250	1989-90	WD-8A-1,2,3,4,5,6	—	—	18-7061	—
V275	1989-91	WD-9/9A-1,2,3,4,5,6	—	—	18-7061	—
V300	1980 & Sup S/N 5611648 & Sup	WD-3, 5	—	—	18-7061	—
XR2	S/N C239553-Sup	WHM-1,2,3B,5,7,8, 8A,11A,12,12A,12B, 13,13B,14A,15,16, 18A,21,22,23,24,25, 28,30,31,32,33,34	—	18-7213	—	—
XR4	1988-90	WH-41,WH-41A	—	18-7005	—	—
XR6/ MAGIII	S/N C239553-Sup	WHM-1,2,3B,5,7,8, 8A,11A,12,12A,12B, 13,13B,14A,15,16, 18A,21,22,23,24,25, 28,30,31,32,33,34	—	—	—	—

① Excepto EFI, XRI

 <p>18-8957 VÁLVULA Reemplaza: 22-8189941, 22-818994</p>	<p>PACK DE 2</p>  <p>18-8956 ACOPLADOR Para manguera de 3/8" to 5/16" Reemplaza: 22-8M0001721</p>	 <p>18-8958 CONECTOR Reemplaza: 22-424254</p>	 <p>18-8866 BOMBA COMBUSTIBLE Reemplaza: 899106T01, 892874T01 Para: Mercury 4 tiempos fueraborda</p>
 <p>18-7804 KIT BOMBA COMBUSTIBLE Reemplaza: 23014A1</p>	 <p>18-7806-1 KIT BOMBA COMBUSTIBLE</p>	 <p>18-7807 KIT BOMBA COMBUSTIBLE Reemplaza: 55278A1</p>	 <p>18-7808 KIT BOMBA COMBUSTIBLE Reemplaza: 55278A5</p>
 <p>18-7809 KIT BOMBA COMBUSTIBLE Reemplaza: 55278A4, 55278A3</p>	 <p>18-7810 KIT BOMBA COMBUSTIBLE Reemplaza: 90363A1</p>	 <p>18-7811 KIT BOMBA COMBUSTIBLE Reemplaza: 89031A1, 66599A1</p>	 <p>18-7812 KIT BOMBA COMBUSTIBLE Reemplaza: 89031A2, 66599A2</p>
 <p>18-7813 KIT BOMBA COMBUSTIBLE Reemplaza: 89031A3, 66599A3</p>	 <p>18-7814 KIT BOMBA COMBUSTIBLE Reemplaza: 89031A4</p>	 <p>18-7815 KIT BOMBA COMBUSTIBLE Reemplaza: 1399-5137</p>	 <p>18-7817 KIT BOMBA COMBUSTIBLE Reemplaza: 21-42990A7, A8, A9, A10, 21-857005A1</p>
 <p>18-7818-1 KIT BOMBA COMBUSTIBLE Reemplaza: 42909A1, 42909A2, 42909A3, 42909A4</p>	 <p>18-7833 MEMBRANA KIT BOMBA Reemplaza: 11497M</p>	 <p>18-7834 MEMBRANA KIT BOMBA Reemplaza: 91748M</p>	 <p>18-7837 MEMBRANA KIT BOMBA Reemplaza: 84262M</p>
 <p>18-7838 MEMBRANA KIT BOMBA Reemplaza: 84265M</p>	 <p>18-7839 MEMBRANA KIT BOMBA Reemplaza: 80606M</p>	 <p>18-7840 MEMBRANA KIT BOMBA Reemplaza: 84141M</p>	 <p>18-7847 MEMBRANA KIT BOMBA</p>

APLICACIONES EN LA PAGINA SIGUIENTE

KITS BOMBA COMBUSTIBLE MERCURY

HP	Desde Nº serie	Hasta Nº serie	Kit bomba comb.	HP	Desde Nº serie	Hasta Nº serie	Kit bomba comb.
7.5	3488153	& Sup	18-7815 ②	115 (4 Cil.)	B209468	& Sup	18-7818-1 ⑥
8	A197112	& Sup	18-7212	115 (4 Cil.)	B209468	& Sup	18-7817 ⑦
9.8	3482753	& Sup	18-7815 ②	115 (115, 1150) SQUARE F/P	6436123	& Sup	18-7817
9.9	A197112	& Sup	18-7212	115 (4 Cil.)	D283222	& Sup	18-7817
10	1057994	1455239	18-7804	115 (6 Cil.) DFI	G960500	T178999	18-7817
15	1200114	1349667	18-7804	115 (3 Cil.) DFI	T801000	& Sup	18-7817
15	B292414	& Sup	18-7212	115 PRO XS	B751825	& Sup	18-7817
20	1866496	2296266	18-7804	120	Todos		18-7806-1
20	3537531	A910970	18-7815 ②	120XR	Todos		18-7806-1
20	6443973	T800749	18-7212	125 (1250) 6 Cil	2314956	2839386	18-7804
20 JET	G044027	& Sup	18-7212	125 (4 Cil.)	D283222	& Sup	18-7817
22	1158546	1499331	18-7804	125 (1250BP) 6 Cil	2400058	2641954	18-7817
25	1467499	1499331	18-7804	125 (3 CYL) DFI	B736885	& Sup	18-7817
25	6443973	& Sup	18-7212	135	2839369	3293233	18-7807
30	950250	1448139	18-7804	V-135	C100860	& inf	18-7812 ①
30 JET	C159200	T408999	18-7817	V-135	A904646	& Sup	18-7817 ⑤
35	6445652	& inf	18-7804	V-135 TRIANGULAR F/P	A904646	C100860	18-7813
35	6445653	B110788	18-7809	V-135 SQUARE F/P	A904646	D081999	18-7817
35	B110789	& Sup	18-7817	V-135	D082000	T178499	18-7817
40 (2 cil.)	831021	1476509	18-7804	V-135 DFI (DESIGN II)	G590000	G760299	18-7817
40 (2 Cil)	2874704	5556229	18-7807	V135 DFI	G760300	& Sup	18-7817
40 (2 Cil)	C159200	& Sup	18-7817	140	3293234	3502805	18-7807
40 (2 Cil)	G053314	& Sup	18-7817	140	4865678	5327662	18-7811
40 (3 Cil)	G590000	T999999	18-7817	140 JET	Todos		18-7817
40 4 tiempos .JET 2 CICLOS	G760300	& Sup	18-7817	150	3502806	4865677	18-7807
45	1139538	1531958	18-7804	150 EFI	G303046	& Sup	18-7817
45 (4 cil.)	B110789	& Sup	18-7817	V-150	C100860	& inf	18-7812 ①
45/50 (4 cil.)	3478003	B110788	18-7815 ②	V-150	A904646	C100860	18-7817 ⑤
45 JET	6428681	& Sup	18-7817	V-150 XR2	Todos		18-7812
45 JET	D000750	T129554	18-7817	V-150 (150HP)	4868998	A904645	18-7812
50 (4 cil.)	2116318	4357639	18-7804	V-150 SQUARE F/P	A904646	C100860	18-7817
50 (3 cil.)	6428681	B122929	18-7809	V-150	C100861	D081999	18-7817
50 (3 cil.)	B122930	T999999	18-7817	V-150 CARB & EFI	D082000	B226999	18-7817
50/55 (3 cil.)	D000750	& Sup	18-7817	V-150 DFI (DESIGN I)	G590000	G760299	18-7817
60	1072997	1542744	18-7804	V-150 DFI (DESIGN II)	G590000	G760299	18-7817
60	6428681	B122929	18-7809	V-150 DFI	G760300	& Sup	18-7817
60 (3 cil.)	B122930	& Sup	18-7817	V-175	C100860	& inf	18-7812 ①
60 (3 cil.)	D000750	& Sup	18-7817	175 EFI	G303046	G589999	18-7817
65	1542745	2803561	18-7804	V-175	6618751	& Sup	18-7817 ⑤
65	ALL 3 Cil		18-7807	V-175 TRIANGULAR F/P	4301235	C100860	18-7812
65 JET	D283222	& Sup	18-7817	V-175 SQUARE F/P	4301235	& Sup	18-7817
65 (650) 4 Cil	2119749	2803561	18-7804	V-175	C100861	D303045	18-7817
70	1143038	1566239	18-7804	V-175	D303046	G960499	18-7817
70 (3 cil)	4571652	6428680	18-7809	V-175 EFI	D000750	D081999	18-7817
70 (3 cil)	A996142	C221999	18-7818-1	V-175 EFI	D082000	T408999	18-7817
75 (4 Cil) CUADRADO F/P	6432901	& Sup	18-7817	V-175 EFI	T409000	T800999	18-7817
75 (3 Cil) VÁLVULA 90 GRADOS	C222000	D283221	18-7818-1	V-175 DFI	T178500	& Sup	18-7817
75 (3 Cil) VÁLVULA EN LÍNEA	C222000	D283221	18-7817	V-175 PRO XS	B516339	& Sup	18-7817
75 (3 Cil)	D283222	& Sup	18-7817	200 EFI	G303046	G589999	18-7817
75 (3 Cil) DFI	T980000	& Sup	18-7817	V-200	6073192	6357229	18-7810
75 (4 cil.)	6432901	& Sup	18-7808 ①	V-200	6357230	6625220	18-7814 ①
75 (4 cil.)	6432901	& Sup	18-7817 ⑤	V-200	4839034	6073191	18-7812
75 (3 cil.)	A996142	D283221	18-7818-1	V-200	6625221	& Sup	18-7817 ⑤
80	1335465	2670574	18-7804 ③	V-200	6625221	C291519	18-7817
80	2783253	2856331	18-7807 ③	V-200	C291520	B226999	18-7817
80	2559001	2670574	18-7808 ④	V-200 EFI	C100861	D081999	18-7817
80	4831999	6432900	18-7808	V-200	D082000	T408999	18-7817
80 (3 Cil)	A966142	C221999	18-7818-1	V-200 (2.5L) EFI	T409000	& Sup	18-7817
80 JET (3 Cil)	0D283222	& Sup	18-7817	V-200 (3.0L) EFI	T750164	& Sup	18-7817
80 JET (4 Cil)	B586067	& Sup	18-7817	V-200 DFI	G590000	T598999	18-7817
85	1460999	1766823	18-7804	V-200 DFI	T599000	T5800999	18-7817
85	3493913	4831998	18-7808	V-200 DFI	T801000	& Sup	18-7817
90 (6 cil.)	1766824	4845300	18-7804	V-200 PRO XS	B504989	& Sup	18-7817
90 (6 Cil)	5299506	6436122	18-7811 ①	V-220 LASER	B117316	& Sup	18-7817
90 (6 Cil)	6436123	& Sup	18-7817 ⑤	V-225	5628028	& Sup	18-7810
90 (3 Cil)	A996142	D283221	18-7818-1	V-225 SEA PRO/MARATHON (3.0L)	D208813	& Sup	18-7817
90 (3 Cil) VÁLVULA EN LÍNEA	C222000	D283221	18-7817	V-225 (3.0L) EFI	G129222	& Sup	18-7817
90 (3 Cil) VÁLVULA 90 GRADOS	C222000	D283221	18-7818-1	V-225 (3.0L) DFI	G590000	T598999	18-7817
90 (3 Cil)	D283222	& Sup	18-7817	V-225 DFI	T599000	T800999	18-7817
90 (3 Cil) DFI	T801000	& Sup	18-7817	V-225 DFI	T801000	& Sup	18-7817
95 (950) 6 Cil	1869776	2318585	18-7804	V-225 DTS	T599000	B417701	18-7817
95XR	Todos		18-7806-1	V-225 DTS	B417702	& Sup	18-7817
100	2318586	3253111	18-7804	V-225 PRO XS	B104549	& Sup	18-7817
100 (4 Cil) VÁLVULA 90 GRADOS	B209468	D283221	18-7818-1 ⑥	V-250 (3.4L)	C101891	& Sup	18-7817
100 (4 Cil) VÁLVULA EN LÍNEA	B209468	D283221	18-7817 ⑦	V-250 (3.0L) EFI	G129222	& Sup	18-7817
100 (4 Cil)	D283222	G965520	18-7817	V-250XB	G980600	T800999	18-7817
105 JET	Todos		18-7817	V-250 DFI	B528615	& Sup	18-7817
110	1870204	2314955	18-7804	V-250 PRO XS	B426561	& Sup	18-7817
115	3761034	& inf		V-275 (3.4L)	C101891	& Sup	18-7817
	18-7807			V-300 (3.4L)	5611648	& Sup	18-7812
115 (6 Cil)	5314656	6436122	18-7813 ①	XR4/XR6	C100860	& Inf	18-7817
115 (6 Cil) TRIANGULAR F/P	6436123	& Sup	18-7817 ⑤	Magnum II	Todos		18-7817

① Excepto modelos con bomba combustible cuadrada
 ② Modelos de carburadores tillotson BA, BB, BD
 ③ Aplicaciones de bomba combustible dual

④ Aplicaciones bomba comb.simp
 ⑤ Con bomba comb. cuadrada

⑥ Use con cuerpo bomba comb blan
 ⑦ Use con cuerpo bomba comb negr

DIAFRAGMAS MARINER (Modelos japoneses)

Modelo	S/N Cod.	S/N	Diafragmas	Modelo	S/N Cod.	S/N	Diafragmas
5C	6E3	TODOS	18-7834	28	644	M-664-151346 & Sup	②
6C	6H8	TODOS	18-7833	30	689	TODOS	②
6D	6H6	TODOS	18-7833	40 TC	6E9	TODOS	②
8B	677	ML-677-316416 & Sup	18-7837	40A APE	676	M-676-A00346 — 001990	18-7839
8B	677	M-677-012921 & Sup	18-7837	40A APE	676	M-676-A001991 & Sup	②
8C	6G1	TODOS	18-7833	40A APE	676	ML-676-A41356 — 302250	18-7839
9.9C	682	TODOS	①	40A APE	676	ML-676-A302251 & Sup	②
15A	651	TODOS	18-7839	40A APE	676	E-676-A10121 — 100355	18-7839
15C	684	TODOS	①	40A APE	676	E-676-A100356 & Sup	②
20A APE	653	TODOS	18-7839	40A APE	676	EL-676-A50631 — 400940	18-7839
20C TPE	6A9	TODOS	②	40A APE	676	EL-676-A400941 & Sup	②
25A	648	EL-648-550230 & inf	18-7839	40B TPE	676	TODOS	②
25A	648	EL-648-550231 & Sup	②	40C TC	6E9	TODOS	②
25A	648	E-648-26825 & inf	18-7839	48	670	ML-670-302510 & inf	18-7839
25A	648	E-648-26826 & Sup	②	48	670	ML-670-302511 — 311995	②
25A	648	ML-648-304174 & inf	18-7839	48	670	M-670-02640 & inf	18-7839
25A	648	ML-648-304174 & Sup	②	48	670	M-670-02641 — 002160	②
25A	648	M-648-19025 & abajo	18-7839	W48	670	ML-670-311996 & Sup	18-7839
25A	648	M-648-19026 & Sup	②	W48	670	M-670-002161 & Sup	18-7839
25C TPE	695	EL-695-550101 — 555959	②	55	663	EL-663-315379 — 317710	18-7839
25C TPE	695	EL-695-555960 & Sup	18-7839	55	663	EL-663-317711 & Sup	②
25C TPE	695	E-695-250101 — 253861	②	55	663	E-663-004041 — 004317	18-7839
25C TPE	695	E-695-253862 & Sup	18-7839	55	663	E-663-004318 & Sup	②
25C TPE	695	ML-695-300101 — 318173	②	55	663	ML-663-36475 & inf	18-7839
25C TPE	695	ML-695-318174 & Sup	18-7839	55	663	M-663-02730 & inf	18-7839
25C TPE	695	M-695-000101 — 023895	②	W55	663	ML-663-578278 — 583880	18-7839
25C TPE	695	M-695-023896 & Sup	18-7839	W55	663	ML-663-583881 & Sup	②
28	644	EL-664-570795 & inf	18-7839	60 2 CIL	6F0	Todos	18-7839
28	644	EL-664-570796 & Sup	②	60 2 CIL	675	EL-675-30101 — 300280	18-7839
28	644	E-664-270310 & inf	18-7839	60 2 CIL	675	EL-675-300281 — 304180	②
28	644	E-664-270311 & Sup	②	60 2 CIL	675	EL-675-304180 & Sup	18-7839
28	644	ML-664-451125 & inf	18-7839	60 2 CIL	675	E-675-00101 — 000180	18-7839
28	644	ML-664-451126 & Sup	②	60 2 CIL	675	E-675-00181 — 001170	②
28	644	M-664-151345 & inf	18-7839	60 2 CIL	675	E-675-001171 & Sup	18-7839

① Requiere el uso del 18-7837 y 18-7838

② Requiere el uso del 18-7839 y 18-7840

ENSAMBLAJE DE LÍNEA DE COMBUSTIBLE COMPLETA LONG. (2,44 mts)

3/8"

ENSAMBLAJE LÍNEA DE COMBUSTIBLE **18-8010EP-1 SILVERADO 4000 Premium**



*

(SE VENDE POR SEPARADO)

COMPONENTES LINEA COMBUSTIBLE

*

ENSAMBLAJE DE LÍNEA DE COMBUSTIBLE COMPLETA LONG. (2,44 mts)

3/8"

FUEL LINE ASSEMBLY

18-8012EP-1 SILVERADO 4000 Premium

**OE# 32-858114Q08,
32-858114K08**



*

Conector de 1/4" con rosca en el lado motor y conector de 1/4" con rosca en el lado depósito. Bomba incluida. para otras aplicaciones modificar los conectores.

COMPONENTES LINEA COMBUSTIBLE

*

ENSAMBLAJE DE LÍNEA DE COMBUSTIBLE COMPLETA LONG. (2,44 mts)

3/8"

FUEL LINE ASSEMBLY

18-8024EP-1 SILVERADO 4000 Premium

**OE# 32-858104Q08,
32-858104K08**



*

Conector rápido en el lado motor y rosca de 1/4" en el lado depósito. Bomba incluida. Para Force 40Hp y posteriores (1993 y posteriores) y todos los Mercury/Mariner.

COMPONENTES LINEA COMBUSTIBLE

*

* Depositos y motores sólo como imagen.

ENSAMBLAJE LÍNEA COMBUSTIBLE COMPLETA LONG. 8'

3/8"
ENSAMBLAJE LÍNEA DE COMBUSTIBLE

18-8025EP-1 *SILVERADO 4000 Premium*

OE# 32-858105Q08,
32-858105K08



*



112315
18-8068
18-8082
CONECTOR

(SE VENDE POR SEPARADO)



112317
CONECTOR
GASOLINA

18-8005S
BOMBA
COMBUSTIBLE

18-8076
CONECTOR
GASOLINA



*

COMPONENTES DE ENSAMBLAJE LÍNEA DE COMBUSTIBLE

Compuesto de conector rápido en el lado motor y uno tipo bayoneta en el depósito.

Bomba incluida. Longitud: 2,44 mts. Para Force 40 (1993 & posteriores) 9.9/15/25HP (1998) y todos los Mercury/Mariner.

ENSAMBLAJE LÍNEA COMBUSTIBLE COMPLETA LONG. 8'

3/8"
ENSAMBLAJE LÍNEA DE COMBUSTIBLE

18-8016EP-1 *SILVERADO 4000 Premium*

OE# 32-858109Q12,
32-858109K12



*



18-80402
CONECTOR
(SE VENDE POR SEPARADO)



18-8091
CONECTOR DE
GASOLINA

18-8005S
BOMBA
COMBUSTIBLE

18-8076
CONECTOR
DE GASOLINA



*

COMPONENTES DE ENSAMBLAJE LÍNEA DE COMBUSTIBLE

Compuesto de conector rápido en el lado motor y lado depósito.

Bomba incluida. Longitud: 2,44 mts. Para Force 40 (1993 & posteriores) 9.9/15/25HP (1998) y todos los Mercury/Mariner.

* Tanques y motores sólo a modo ilustrativo

BOMBA COMBUSTIBLE



18-8002S
112350
BOMBA
COMBUSTIBLE 1/4" (6-7mm)

18-8004
112352 (8-10mm)
BOMBA COMBUSTIBLE
5/16" (8mm)
Reemplaza: 89396A38,
89396Q38
Bomba de gran capacidad

18-8005S
112352 (8-10mm)
BOMBA COMB.
3/8" (10mm)
Reemplaza: 13330A3,
13330Q, 13330Q5
Bomba de gran capacidad



RACOR MANGUERA



REF #	MERCURY OE #	ROSCA	NPT	TIPO CONECTOR
18-8054	22-63186	5/16"	1/8"	Macho
18-8055	22-63187	5/16"	1/4"	Macho
18-8073	-	3/8"	1/8"	Macho
18-8074	-	3/8"	1/4"	Macho



18-7083
BOMBA COMBUSTIBLE
Reemplaza: 858763, 8168773, 8168772, 8168771, 816877, 684311
Para: 30 2cil (Todos), 30 JET 3 cil. (Todos), 40 2 cil. (Todos), 40 3 cil. (Todos), 40 JET(Todos), 50 3 cil. (G590000 & Sup), 55 3 cil. (G590000 & Sup), 60 3 cil. (G590000 & Sup), 60 3cil Bigfoot (Todos), 65 JET (Todos), 75 3 cil. (D283222 & Sup), 90 3 cil. (D283222 & Sup)



18-80410
CONECTOR COMBUSTIBLE
Reemplaza: 22-13563T3
Racor manguera hembra
5/16"
Para: 4/5 2-Tiempos (1999 & Sup)
Se adapta 18-80412



18-80412
CONECTOR COMBUSTIBLE
Reemplaza: 22-816856T2
Conector manguera macho
5/16"
Para: 100 4-cil. (1988-99), 115 4-cil. (1989 & Sup), 125 4-cil. (1994 & Sup), 65 Jet (1994 & sup), 75 3-cil. (1987 & Sup), 80 Jet (1994 & Sup), 90 3-cil. (1987 & Sup) se adapta 18-80410



18-8068
112315
CONECTOR
(1/4" NPT)
(Hembra)



18-8069
112316
CONECTOR COMBUSTIBLE
5/16"
Reemplaza: 22831Q3, 22831A3, 22831A4, 22831B3, 22831A1
(Hembra)



112317
FUEL CONNECTOR
5/16"
Reemplaza: 30185A3, 30185Q3, 30185B3, 30185A1, 29196, 16610M
(Macho)



18-8075
CONECTOR COMBUSTIBLE
(1/4")
Reemplaza: 22-14213M, 2214213Q, 22-81042M
Se adapta 18-8077-1



18-8076
18-8076-10^①
CONECTOR COMBUSTIBLE
(3/8")
Reemplaza: 22-13563A3, 22-13563Q3
Se adapta 18-8077-1



18-8077-1
18-8077-1-10^①
CONECTOR
(1/4" NPT)
Se adapta 18-8075, 18-8076, 18-8085



18-8082
112315
DEPÓSITO CONECTOR
Conector Mercury recto
(1/4" NPT)
(Hembra)



18-8083
CONECTOR COMBUSTIBLE
3/8"
(Hembra)



112317
CONECTOR COMBUSTIBLE
3/8"
Reemplaza: 30185A3, 30185Q3, 30185B3, 30185A1, 29196, 22-16610M
(Hembra)



18-8085
18-8085-10^①
CONECTOR COMBUSTIBLE
(5/16")
Se adapta 18-8077-1



18-8091
CONECTOR COMBUSTIBLE
(3/8")
Reemplaza: 22-13563Q7, 22-13563T7, 22-13563A7
22-13563A6
Se adapta 18-80402



18-80402
CONECTOR COMBUSTIBLE
(1/4" NPT)
Se adapta 18-8091

① Descuento en tienda por pack de 10 - Precio por pack

- DISEÑO UNIVERSAL -
REEMPLAZO DIRECTO PARA MERCURY Y YAMAHA
SOPORTE FILTRO GASOLINA



Tipo de soporte	Ref #	Reemplaza	Tipo de soporte	Ref #	Reemplaza
1/4" acero inoxidable	18-7777		1/4" Aluminio	18-7853-1	Mercury 89876A3, 89876, 55481
3/8" acero inoxidable	18-7776		3/8" Aluminio	18-7775	

KIT FILTROS GASOLINA



KIT FILTROS DE 21 MICRONES PARA MOTORES CARBURACIÓN

TIPO DE KIT	Ref #	Capacidad Filtrado	Contenido	Reemplaza
1/4" Aluminio (Filtro corto)	18-7848-1	21	1 - 18-7844 filtro & 1 18-7853-1 soporte 2 - 18-4256 1/4" tapones	35-807172A4, Q4, 35-60494A4, 35-805369A4, 35-57250A1, 35-55501A1, 35-52456A1, 35-60494A1, 52444
1/4" Aluminio Bonus Pack Contiene filtro de repuesto	18-7848-2 508522	21	2 - 18-7844 filtro & 1 18-7853-1 soporte 2 - 18-4256 1/4" tapones	
1/4" Aluminio (Filtro alto)	18-7852-1	21	1 - 18-7845 filtro & 1 18-7853-1 soporte 2 - 18-4256 1/4" tapones	
1/4" Aluminio Bonus Pack Contiene filtro de repuesto	18-7852-2	21	2 - 18-7845 filter & 1 18-7853-1 soporte 2 - 18-4256 1/4" tapones	
3/8" Aluminio (Filtro alto)	18-7775-1	21	1 - 18-7845 filter & 1 18-7775 soporte 2 - 18-4264 3/8" tapones	
1/4" acero inoxidable (Filtro alto)	18-7777-1	21	1 - 18-7845 filtro & 1 18-7777 soporte 2 - 18-4256 1/4" tapones	
3/8" acero inoxidable (Filtro alto)	18-7776-1	21	1 - 18-7845 filtro & 1 18-7776 soporte 2 - 18-4264 3/8" tapones	

KITS FILTROS 10 MICRONES PARA MOTORES DE INYECCIÓN



Tipo de kit	Ref #	Capacidad filtrado	Contenido
1/4" Aluminio (Filtro corto)	18-7983-1	10	1 - 18-7944 filtro & 1 18-7853-1 soporte • 2 - 18-4256 1/4" tapones
1/4" Aluminio Bonus Pack (Contiene filtro de repuesto)	18-7983-2	10	2 - 18-7944 filtro & 1 18-7853-1 soporte • 2 - 18-4256 1/4" tapones
1/4" Aluminio (Filtro alto)	18-7982-1	10	1 - 18-7945 filtro & 1 18-7853-1 soporte • 2 - 18-4256 1/4" tapones
1/4" Aluminio Bonus Pack (Contiene filtro de repuesto)	18-7982-2	10	2 - 18-7945 filtro & 1 18-7853-1 soporte • 2 - 18-4256 1/4" tapones
1/4" Aluminio (Gran capacidad Filtro)	18-7966-1	10	1 - 18-7866 filtro & 1 18-7853-1 soporte • 2 - 18-4256 1/4" tapones
3/8" Aluminio (Filtro alto)	18-7986-1	10	1 - 18-7945 filtro & 1 18-7775 soporte • 2 - 18-4264 3/8" tapones
1/4" Acero inoxidable (Filtro alto)	18-7984-1	10	1 - 18-7945 filtro & 1 18-7777 soporte
3/8" Acero inoxidable (Filtro alto)	18-7985-1	10	1 - 18-7945 filtro & 1 18-7776 soporte • 2 - 18-4264 3/8" tapones
1/4" Aluminio (Filtro alto)	18-79912	10	1 - 18-79911 & 1 - 18-7853-1



KIT FILTROS 10 MICRONES CON VASO DECANTADOR

El vaso transparente Sierra AquaVue™ se usa para fueraborda e instalaciones en cubierta . El vaso metálico antiinflamable se usa para instalaciones bajo cubierta. Los filtros con vaso decantador transparente o metálico permiten drenar el agua, alargando la vida útil del elemento filtrante.

Tipo Kit	Ref #	Capacidad filtrado	Contenido
1/4" Aluminio c/ vaso AquaVue™	18-7932-1	10	1 - 18-7919 filtro & 1 18-7853-1 Soporte 1 - 18-7922-1 vaso AquaVue™ 2 - 18-4256 1/4" tapones
1/4" Aluminio c/ cazoleta desagüe	18-7951	10	1 - 18-7919 filtro & 1 18-7853-1 soporte 1 - 18-7924 Cazoleta metálica 2 - 18-4256 1/4" tapones
1/4" Acero inoxidable c/ vaso AquaVue™	18-7937-1	10	1 - 18-7919 filtro & 1 18-7777 soporte 1 - 18-7922-1 vaso AquaVue™ 2 - 18-4256 1/4" tapones
1/4" Acero inoxidable c/ cazoleta desagüe	18-7938	10	1 - 18-7919 filtro & 1 18-7777 Soporte 1 - 18-7924 cazoleta metálica 2 - 18-4256 1/4" tapones

SOPORTE COMPACTO Y KIT SEPARADOR PARA PEQUEÑOS FUERABORDA Y APLICACIONES EN AGUA DULCE



18-7774
SOPORTE DE ALUMINIO COMPACTO

18-7965-1
KIT SEPARADOR 10 MICRONES COMPACTO
Contiene:
1 - 18-7774 soporte
1 - 18-7865 filtro



FILTROS REPUESTO



DISEÑO UNIVERSAL- REPUESTO DIRECTO PARA MERCURY Y YAMAHA

FILTRO DE REPUESTO 10 MICRONES			FILTRO DE REPUESTO 10 MICRONES		
Ref #	Descripción	Reemplaza	Ref. #	Descripción	Reemplaza
18-7944	Corto - 3.875"	35-807172, 35-802893Q, 35-806771, 35-8053691, 35-805369, 35-604941, 35-60494, 35-57250, 35-55501, 35-52456,	18-79911	Largo - 8.5"	35-8M0079962
18-7945	Largo - 4.35"	35-802893Q, 35-806771, 35-8053691, 35-805369, 35-604941, 35-60494, 35-57250, 35-55501, 35-52456	FILTRO DE REPUESTO 21 MICRONES		
18-7866	Gran capacidad - 6"		18-7844	corto- 3.875"	35-807172, 35-807172, 35-806771,
18-7865	10 micrones compacto		18-7845	Largo - 4.35"	35-8053691, 35-60494A4, 35-604941,
18-7967	Primeros modelos c/ sensor	35-18458Q3, 35-18458A3, 35-18458A2, 35-17808A1, 35-14571A1	810031		35-57250, 35-55501
18-7968	Ultimos modelos c/ sensor	35-18458Q4, 35-184585	<p>18-8955 TAPA Para: 18-7944 & 18-7945 filtro</p>		
<p>FILTROS DE REPUESTO 10 MICRONES CON VASO DECANTADOR (CONSULTE LA TABLA DE ABAJO)</p>					

FILTROS DE REPUESTO			FILTROS Y KITS CAZOLETAS	
Ref #	Descripción	Reemplaza	Ref. #	Descripción
18-7919	Elemento filtrante	35-809097, 35-8M0103095 Racor S3213	18-7928-1	Filtro & vaso AquaVue™ Estilo Mercury Contiene: 18-7919 filtro, vaso18-7922-1
18-7920	Elemento filtrante	35-809099 Racor S3214	18-7929	Filtro & Cazoleta metálica Estilo Mercury Contiene: 18-7919 filtro, vaso18-7924
18-7948	Elemento filtrante Para - 320RRAC01	35-886638 Racor S3227	18-7969	Filtro & cazoleta metálica Contiene: 18-7948 filtro, vaso18-7924
REPUESTO DE VASO DECANTADORES			18-7994-1	Filtro & vaso AquaVue™ Contiene: 18-7948 filtro, vaso18-7922-1
Part #	Descripción			
18-7922-1	Recipiente AquaVue™			
18-7924	Recipiente metal			

<p>18-7936 ELEMENTO FILTRO COMBUSTIBLE Reemplaza: 35-888289T2 Para: 225 EFI (2003-06) (SN OT653945 & Sup)</p>	<p>18-7712 FILTRO COMBUSTIBLE (EN LÍNEA) Reemplaza: 35-16248 Para: 4/5 2 cil (1999 & Sup), 4/5/6 4 tiempos (1999 & Sup), 8/9.9 4-tiempos (2005 & Sup)</p>	<p>18-7713 FILTRO COMBUSTIBLE (EN LÍNEA) Reemplaza: 35-80365M Para: Mercury/Mariner 9.9 4-tiempos (1995-98), 15 4-tiempos (1998 & Sup), Yamaha 6 (1989, 1992-99), 8 (1989-99, 2001-02), F4 (1999-02), F9.9 (1989-95, 1997-99, 2001-02), FT 9.9 (1988-90)</p>
<p>18-7714 FILTRO COMBUSTIBLE (EN LÍNEA) Reemplaza: 35-877565T1 Para: 25 4-tiempos (1998 & Sup), 30 4-tiempos (1999-01), 30 3 cil 4-Tiempos (1999-01), 40 4-Tiempos (1998-01), 40 4_tiempos 4 cil (2001-02), 40 Carb 3-cil 4-tiempos (2002 & Sup), 50 4-tiempos 4 cil (2001-02), 60 4-tiempos 4 cil (2001-02), 75 4-tiempos (2000 & Sup), 90 4-tiempos (2000 & Sup)</p>	<p>18-7718 FILTRO COMBUSTIBLE (EN LÍNEA) 5/16" Reemplaza: 35-879885T Para: 135/150/175 4-tiempos Verado (S/N 1B227000 & Sup), 200/225 4-tiempos Verado (S/N OT980000 & Sup), 250/275 4-tiempos Verado (S/N OT801000 & Sup)</p>	<p>18-7802 FILTRO COMBUSTIBLE Reemplaza: 35-87946A3, 35-87946-Q3, Q4 Para: 6 HP hasta 25 HP</p>
<p>18-7832 FILTRO COMBUSTIBLE Reemplaza: 1399-3938, 1399-1754, 1399-1136 Para: AJ, KA, KB, KC, KD, WM, WMC Carb.</p>	<p>18-7979 FILTRO COMBUSTIBLE Reemplaza: 881540 Para: 115 EFI (4 tiempos), 75HP (4 tiempos), 75HP (4 tiempos) (Bodensee), 90HP (4 tiempos)</p>	<p>18-7981 FILTRO COMBUSTIBLE Reemplaza: 35-884380T, 35-8M0020349 Para: Todos Verados, 90HP (DFI) (3 cil), 115 DFI (3 cil) / 200HP (DFI) / 225HP (DFI) (incluida 3.0L DFI)</p>



Ref #	Aplicación
18-7828-1	1/4" Pequeña capacidad (Para 1/4" manguera)
18-7829	1/4" gran capacidad (para 1/4" manguera) Reemplaza: 35-16494, 35-816296, 35-816296T, 35-816296K03
18-7830	5/16" Reemplaza: 35-164941, 35-816296-1, 35-816296T1, 35-8162961, 35-816396Q1 35-816296B2, 35-816296B1, 35-134301
18-7831	3/8" Reemplaza: 802128A1

PACK DE 10

18-7113-9②
ARO TÓRICO
Reemplaza: 25-897536, 25-98277
Para: Filtro 18-7802 (35-87946Q3)

18-7997
FILTRO DE AIRE
Reemplaza: 35-853333T, 35-853333
Para: V115 DFI (2.5L) (2000), V-135 DFI (2.5L) (1998 & Sup), V-150 DFI (2.5L) (1998 & Sup), V-175 DFI (2.5L) (2001 & Sup), 200 DFI (1998-02), 225 DFI (1998-02)

18-7999
FILTRO DE AIRE
Reemplaza: 35-896247
Para: 135/150/175 4-tiempos Verado (S/N 1B227000 & Sup)

18-3605
KIT TERMOSTATO
Para: V-135 DFI (2.5L) (1998 & Sup), V-150 DFI (2.5L) (1998 & Sup), V-175 DFI (2.5L) (2000 & Sup)

18-3606
KIT TERMOSTATO 130°
Para: 200 3.0L DFI DTS (Todos), 200 3.0L EFI (2003 & Sup) (OT750164 & Sup), 200 DFI (1997 & Sup) (OG386496 & Sup), 225 3.0L EFI (1999 & Sup) (OG760300 & Sup), 225 3.0L EFI SeaPro (2004 & Sup) (OT801000 & Sup), 225 3.0L DFI DTS (2003 & Sup) (OT599000 & Sup), 225 DFI (1998 & Sup) (OG590000 & Sup), 250 3.0L EFI (1999 & Sup) (OG760300 & Sup), 250 Largo 3.0L EFI (OT861319 & Sup)

18-43175
KIT TERMOSTATO 130°
Reemplaza: 855676002
Para: Mercury 15 Carb(2cil) 4-Tiempos (R235949 & Sup), 15 SeaPro 4-Tiempos (R051685 & Sup), 20 Carb(2cil) 4-tiempos (R235168 & Sup), 25 EFI(3cil) 4-tiempos (R106999 & Sup), 25 Jet EFI(3cil) 4-tiempos (R165086 & Sup), 25 SeaPro 4-tiempos (R051710 & Sup), 30 EFI(3cil) 4-tiempos (T409000-1B226999), 8 4-tiempos (209cc) (R042475 & Sup), 9.9 4-tiempos (209cc) (R042475 & Sup)

18-3672
KIT TERMOSTATO
- CONTIENE -

Ref #	Desc.	O.E. #
18-3553	Termostato, latón	75692
18-0182	Junta termostato	27-62386

HP	Desde S/N	Hasta S/N	HP	Desde S/N	Hasta S/N
V135	A904646 & Sup	V150 MAGII C239553	4571651		
V150	A904646 & Sup	V150 MAGIII D082000	4825248		
V150 XR4	C239553	C159199	V175 C100861 & Sup		
V150 XR6	D082000 & Sup	V200	6435503 & Sup		

18-3569
KIT TERMOSTATO
Reemplaza: 803061T1
Incluye 18-3549 termostato

HP	Desde S/N	Hasta S/N	HP	Desde S/N	Hasta S/N
70 3 cil.	A996142 & Sup	100 4 cil.	B209468 & Sup		
75 3 cil.	C222000 & Sup	115 4 cil.	C100000 & Sup		
80 3 cil.	A996142 & Sup	125 4 cil.	D283222 & Sup		
90 3 cil.	A996142 & Sup				

18-43052
KIT TERMOSTATO
Reemplaza: 14586A3, 75962A9, 75962A10, 75962A11
Para: Mercury 6-25 hp 2-Tiempos

18-3535
TERMOSTATO 130°
Reemplaza: 885599004
Para: 200 3.0L DFI DTS (Todos), 200 3.0L EFI (2003 & Sup) (OT750164 & Sup), 200 DFI (1997 & Sup) (OG386496 & Sup), 225 3.0L EFI (1999 & Sup) (OG760300 & Sup), 225 3.0L EFI SeaPro (2004 & Sup) (OT801000 & Sup), 225 3.0L DFI DTS (2003 & Sup) (OT599000 & Sup), 225 DFI (1998 & Sup) (OG590000 & Sup), 250 3.0L EFI (1999 & Sup) (OG760300 & Sup), 250 Largo 3.0L EFI (OT861319 & Sup)

18-3536
TERMOSTATO 143°
Reemplaza: 833072003
Para: V135 DFI 2.5L (1998 & Sup) (OG590000 & Sup), V150 DFI 2.5L (1998 & Sup) (OG590000 & Sup), V175 DFI 2.5L (2001 & Sup) (OT178500 & Sup)

18-3537
TERMOSTATO 143°
Reemplaza: 833072002, 833072004
Para: 75 3 cil DFI 1.5L (2006 & Sup) (OT980000 & Sup), 90 3 cil DFI 1.5L (2004 & Sup) (OT801000 & Sup), 115 3 cil DFI 1.5L (2004 & Sup) (OT801000 & Sup)

① Referencias acabadas en D envasadas
② Precio envasado

TABLA EQUIVALENCIA TURBINA MERCURY

MOTOR MERCURY	REFERENCIA MERCURY	PRONAUTIC
F 2,5 4 STOKES	47-16154 3	18-3098
F 3,5 4 STOKES	47-16154 3	18-3098
F 4 4 STOKES	47-16154 3	18-3098
F 5 4 STOKES	47-16154 3	18-3098
F 6 4 STOKES	47-16154 3	18-3098
F 8 4 STOKES NOBIG FOOD 209CC	47-803748	18-8920
F 8 4 STOKES BIG FOOD 209CC	47-803748	18-8920
F 9,9 4 STOKES NO BIG FOOD 209 CC	47-803748	18-8920
F 9,9 4 STOKES BIG FOOD 209 CC	47-803748	18-8920
F 9,9 4 STOKES NO BIG FOOD 323 CC	47-42038Q02	18-3062
F 9,9 4 STOKES BIG FOOD 323 CC	47-85089-10	18-3057
F 15 4 STOKES	47-803748	18-8920
F 20 4 STOKES	47-803748	18-8920
F 25 4 STOKES	47-85089-10	18-3057
F 30 4 STOKES	47-85089-10	18-3057
F 25 4 STOKES EFI	47-16154-1	MER4716541
F 30 4 STOKES EFI	47-16154-1	MER4716541
F 40 4 STOKES	47-19453T	18-8900
F 50 4 STOKES	47-19453T	18-8900
F 60 4 STOKES	47-19453T	18-8900
F 75 F 90 4 STOKES	47-43026Q2	18-3056
F 80 F 100 F 115 4 STOKES	47-43026Q2	18-3056
OPTIMAX 75 DFI, OPTIMAX 90 DFI	47-43026Q2	18-3056
OPTIMAX 115 DFI	47-43026Q2	18-3056
F 150 4 STOKES	47-43026Q2	18-3056
VERADO 135, VERADO 150, VERADO 175, VERADO 200	47-43026Q2	18-3056
OPTIMAX 200 DFI, OPTIMAX 250 DFI	47-43026Q2	18-3056
VERADO 250, VERADO 275, VERADO 300, VERADO 350	47-43026Q2	18-3056
2,2 2 STOKES, 2,5 2 STOKES, 3,3 2 STOKES	47-95289-2	18-45312
2,5 2 STOKES, 3,3 2 STOKES (modernos)	47-16154-3	18-3098
4 2 STOKES, 5 2 STOKES	47-16154-3	18-3098
6 2 STOKES	47-42038Q02	18-3062
8, 9,9, 10, 13,5, 15 2 STOKES	47-42038Q02	18-3062
20 y 25 2 STOKES	47-85089-10	18-3057
30 2 STOKES ON055512 Y Superiores	47-16154-1	MER4716541
40 y 50 2 STOKES	47-85089-10	18-3057
60 2 STOKES	47-19453T	18-8900
75, 90, 100 y 115 2 STOKES	47-43026Q2	18-3056
150 y 200 PRO XS V6	47-89984T3	18-3017
225 3.0 L y 250 3.0L IEFI	47-43026Q2	18-3056
400 VERADO	47-43026Q2	18-3056
600 V12	8M0177706	MER8M0177706



18-3553
TERMOSTATO
Reemplaza: 62981, 66850, 75692
143°

18-3553 APLICACIÓN TERMOSTATO					
HP	Desde	Hasta	HP	Desde	Hasta
7.5	5226935	& Sup	V150	A904646	& Sup
9.8	5206550	& Sup	V175	C100861	& Sup
40	3336258	C159199	V200	6435503	& Sup
50/60	D000750	& Sup	V220	B117316	& Sup
65	3547987	4571651	V225	5628028	& Sup
70	4571652	4825248	V300/3.4L	5611648	& Sup
70/75/80/90	A996142	& Sup	XR4	C239553	D081999
100/115	B209468	& Sup	Magnum II	C239553	D081999
V135	A904646	& Sup			



18-3549
TERMOSTATO
Reemplaza: 14586
Para: 6, 7, 8, 9,9 & 15 HP
Mercury/Mariner A197112 & posterior
120°

18-3549 APLICACIÓN TERMOSTATO		
MARINER		
HP	Serie #	
6,8,9,9 (2 cil.)	A197112	posterior
Sea Pro 10	D038000	posterior
15 (2 cil.)	B292414	posterior
18XD, 20XD, 25XD	B114231	posterior
25 (2 cil.) 25 Sea Pro	B238464	posterior
30 (2 cil.)	G055314	posterior
45 Jet, 50, 55, 60 (3 cil.)	G290585	posterior
MERCURY		
Sea Pro 10	D038000	posterior
15 (2 cil.)	B292414	posterior
18XD, 20XD, 25XD	B114231	posterior
25 (2 cil.) 25 Sea Pro	B238464	posterior
30 (2 cil.)	G055314	posterior
45 Jet, 50, 55, 60 (3 cil.)	G290585	posterior



18-3631
ALOJAMIENTO TERMOSTATO
Reemplaza: 892864T04
Para: 135-300 Verado



18-3556
TERMOSTATO
Reemplaza: 895338
3/4" - 130°



18-43051
KIT TAPA TERMOSTATO
Para: Mercury V6



18-5896
SENSOR DE TEMPERATURA
Reemplaza: 12415
1/8" - 27NPT rosca



18-3094
IMPULSOR
Reemplaza: 47-89983,
47-89983T



18-3008
IMPULSOR
Reemplaza: 47-20813, 47-25287



18-3012
IMPULSOR
Reemplaza: 47-22748

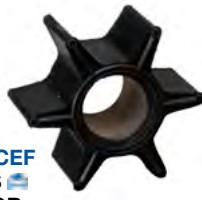

18-3017 CEF
18-3017S
IMPULSOR
Reemplaza: 47-89984, 47-899842,
47-89984T3, 47-89984T4, 47-
899844, 47-30221, 47-65960,
47-85460



IMPULSOR
Ref # ID Reemplaza:
18-3039 .456" 47-65957, 47-89981, 47-39074
18-3054 .438" 47-68988, 47-89980



18-3052
IMPULSOR
Reemplaza: 47-56780, 47-65958,
47-89982



18-3056 CEF
18-3056S
IMPULSOR
Reemplaza: 47-430261, 47-430262,
47-43026T2, 47-430264



18-3057 CEF
18-3057S
IMPULSOR
Reemplaza: 47-85089-3



18-3062
IMPULSOR
Reemplaza: 47-420381, 47-420382,
47-42038Q02



18-3063
IMPULSOR
Reemplaza: 47-95611M, 47-81242M



18-3066
IMPULSOR
Reemplaza: 47-11590M



18-3067
IMPULSOR
Reemplaza: 47-84797M, 47-81604M



18-3069
IMPULSOR
Reemplaza: 47-81423M, 47-
97108M, 47-82824M



18-3072
IMPULSOR
Reemplaza: 47-80395M

APLICACIONES EN LA PÁGINA 58 y 66

① Descuento en tienda pack de 10 - Precio por pack

 <p>18-3073 CEF 18-3073S IMPULSOR Reemplaza: 47-96305M</p>	 <p>18-3074 CEF 18-3074S IMPULSOR Reemplaza: 47-84027M, 47-84027T, 47-96619M</p>	 <p>18-3098 IMPULSOR Reemplaza: 47-161543, 47-16154</p>	 <p>18-45312 IMPULSOR Reemplaza: 47-95289, 47-952892 Para: Mercury 2(T884302 & Sup), 2.5(A855097 & Sup), 3.3(G710613 & Sup)</p>		
 <p>18-8900 CEF 18-8900S IMPULSOR Reemplaza: 47-19453</p>	 <p>18-3293 CHAVETA Reemplaza: 28-43037</p>	 <p>18-3300 CHAVETA Reemplaza: 28-83444M Para: 40A, 40B, 40C</p>  <p>18-3305 CHAVETA Reemplaza: 28-81912M, 28-83070M, Para: 6C-D, 8C, 9.9C, 15C</p>	 <p>18-1839 RETEN LARGO (2 1/4") Reemplaza: 8235471. Para 25 (4T), 30 (2 cil.), 30 (4T), 40 (2 cil.), 40 (3 cil.), 40 (4T), 50 (3 cil.), 50 (4T), 5 0-BIGFOOT (4T)</p>	 <p>18-1838 RETEN CORTO (1 3/4") Reemplaza: 43023 25(4T), 30 (2 II), 30 (4T), 40 (2 cil), 40 (3 cil), 40 (4T), 50 (3 cil), 50 (4T), 50 Bigfoot (4T)</p>	 <p>18-3154 ALOJAMIENTO Reemplaza: 826763A</p>
 <p>18-3109 TUBO GUÍA Reemplaza: 23-29804, 23-29804T, 23-52928 (Usar con alojamiento 18-3116)</p>	 <p>18-3013 RETÉN BOMBA DE AGUA Reemplaza: 26-821309 Para: 4-tiempos O/B's, 25/30/40/45/50 HP s/n OG760300 & Sup</p>	 <p>18-3110 CASQUILLO Reemplaza: 26-38970, 26-36557A1, 26-29677 (Parte del alojamiento 18-3116)</p>	 <p>18-3014 RETÉN BOMBA DE AGUA Reemplaza: 26-821310 Para: 4-Tiempos O/B's, 25/30/40/45/50 HP s/n OG760300 & Sup</p>	 <p>18-3151 ALOJAMIENTO Reemplaza: 816597</p>	
<p>Pack de 5</p>  <p>18-3227 ① 18-3227-9 CLAVIJA BASE BOMBA DE AGUA Reemplaza: 17-35973 Para: 20-225HP S/N 1866496-Sup</p>	 <p>18-1730 ACOPLAMIENTO Reemplaza: 43585 Para: 200, 225, 250 & 275 Verado</p>	 <p>18-3113 ALOJAMIENTO Reemplaza: 70977</p>	 <p>18-3114 ALOJAMIENTO Reemplaza: 48752, 48752T</p>	 <p>18-3115 ALOJAMIENTO Reemplaza: 48753</p>	
 <p>18-3435 ALOJAMIENTO TURBINA</p>	 <p>18-3107 PLATINA IMPULSOR Reemplaza: 54705, 32768</p>	 <p>18-3117 IMPULSOR PLATINA Reemplaza: 32435, 324351, 30605</p>	 <p>18-3122 IMPULSOR PLATINA Reemplaza: 817276, 8172761, 8172763</p>		
 <p>18-3139 IMPULSOR PLATINA Reemplaza: 46895</p>	 <p>18-3436 IMPULSOR PLATINA</p>	 <p>18-3116 ALOJAMIENTO BOMBA Reemplaza: 46-96418, 46-96148A1, 46-96148T1, 46-64141A1, 46-48743A1</p>	 <p>18-4577 PLATINA Reemplaza: 8213542</p>	 <p>18-3118 ALOJAMIENTO BOMBA Reemplaza: 46-48746A1, 46-77822A1, 46-48746A3</p>	



18-3414
BASE BOMBA
Reemplaza: 46-96146A5, 46-73804A1



18-3416
BASE BOMBA
Reemplaza: 46-96146A6, 46-96146A2, 46-78400A1, 46-73802A2



18-3419
BASE BOMBA
Reemplaza: 46-42579A3



18-3422
BASE BOMBA
Reemplaza: 46-77516A1, 46-73842A2, 46-68390A1, 46-65498A1, 46-48745A1



18-3423
BASE BOMBA
Reemplaza: 46-73640A1



18-3424
BASE BOMBA
Reemplaza: 46-77177A1



18-3445
BASE BOMBA
Reemplaza: 46-812966A7, 46-812996A3, 46-812996A9
Para: 40-60 HP



18-43212
ALOJAMIENTO BOMBA
Reemplaza: 46-803750A02, 46-8037502
Para: Mercury 8/9.9 4-tiempos(209cc)



18-3207
KIT REPARACIÓN IMPULSOR
Reemplaza: 47-89983T2, 47-89983Q1
— CONTIENE —



18-3214
KIT REPARACIÓN IMPULSOR
Reemplaza: 47-43026T6, 47-43026T8, 47-43026T11
— CONTIENE —

Ref #	Descripción	O.E. #	Cant.
18-3007	Impulsor	47-89983	1
18-2945	Junta drenaje	12-20260,12-19183	2
18-2823	Junta bomba de agua	27-32769, 27-19553	1
18-2824	Junta cuerpo de bomba	27-32770	1
18-2825	Junta bomba de agua	27-32771,27-19551	1
18-2841	Junta bomba de agua	27-77417,27-19552	1
18-2948	Arandela goma	12-49221-1	1
18-3107	Platina	54705	1
18-7155	Aro tórico	25-26855	1
18-7174	Aro tórico	25-45711	1
18-7115	Aro tórico	25-26722	1

ref #	Descripción	O.E. #	Cant.
18-2564	Base bomba agua platina	27-43033-1	1
18-2565	Base bomba de agua alojamiento	27-43047-1	1
18-2566	Platina tapa bomba agua	27-817277	1
18-2944	Retén	26-45577	1
18-3056	Impulsor	47-43026-1	1
18-3122	Impulsor	817276	1
18-7420	Aro tórico	25-21836	1



18-3215
KIT REPARACIÓN IMPULSOR
Reemplaza: 47-85089T7
— CONTIENE —



18-3149-1
KIT BOMBA DE AGUA
Reemplaza: 46-42040A1, 46-42040A3, 46-42040A5, 46-42040T5
Para: 10 Magnum, Marathon, Sea Pro, Viking
15 Marathon, Sea Pro 6, 8, 9.9HP, XR10

Ref #	Descripción	O.E. #	Cant.
18-2560	Junta impulsor	12-86645	2
18-2561	Alojamiento platina	27-85087	1
18-2562	Alojamiento platina	27-99326-1	1
18-3057	Impulsor	47-85089-3	1
18-7419	Aro tórico	25-69202	1

18-3149-1
KIT BOMBA DE AGUA
Reemplaza: 46-42040A1, 46-42040A3, 46-42040A5, 46-42040T5
Para: 10 Magnum, Marathon, Sea Pro, Viking
15 Marathon, Sea Pro 6, 8, 9.9HP, XR10

APLICACIONES EN LA PÁGINA 58 y 66

① Referencias acabas de D envasadas



18-3265

KIT REPARACIÓN IMPULSOR

Reemplaza: 47-43026Q06, 47-43026T11, 47-8M0100526

Para: 135/150/175 4-tiempos Verado (S/N 1B227000 & Sup),200/225 4-Tiempos Verado (S/N OT980000 & Sup), 250/275 4-tiempos Verado (S/N OT801000 & Sup)

①18-3217D



**18-3217
KIT IMPULSOR**

Reemplaza : 46-96148A5 sin base o alojamiento

— CONTIENE —

Ref #	Descripción	O.E. #	Cant.
18-3109	Tubo de agua	23-29804	1
18-3017	Impulsor	47-89984	1
18-2919	Junta bomba de agua	27-42631-1	1
18-3110	Casquillo	26-38970	1
18-2945	Junta drenaje	12-20260,12-19183	2
18-2826	Base bomba agua alojamiento	27-85610	1
18-2914	Junta bomba de agua	27-85608-1	1
18-2915	Junta bomba de agua	27-85609-1	1
18-2944	Retén	26-45577	1
18-3117	Platina	32435	1
18-7158	Aro tórico	25-30613	1
18-7162	Aro tórico	25-33145	1
18-7173	Aro tórico	25-30224	1
18-7176	Aro tórico	25-90011	1
18-2801	Junta bomba de agua	27-32438	1
18-7426	Aro tórico	35-30271	1

①18-3239D



18-3239

KIT REPARACIÓN IMPULSOR

— CONTIENE —

Ref #	Descripción	O.E. #	Cant .
18-3039	Impulsor	47-89981	1
18-3139	Impulsor platina	46895	1
18-7409	Aro tórico	—	1



18-3252

KIT REPARACIÓN IMPULSOR

Reemplaza: 47-89982T1

— CONTIENE —

Ref #	Descripción	O.E. #	Cant.
18-2004	Retén aceite	26-20070	2
18-2006	Retén aceite	26-897154	1
18-2827	Junta platina superior	27-39623	1
18-2828	Junta platina superior	27-39625	1
18-3052	Impulsor	47-89982	1
18-7164	Aro tórico	25-33466	1



18-3406

KIT REPARACIÓN BOMBA DE AGUA

Reemplaza: 817275A08

Para: 135/150/175 4-tiempos Verado (S/N 1B227000 & Sup),200/225 4-tiempos Verado (S/N OT980000 & Sup), 250/275 4-tiempos Verado (S/N OT801000 & Sup)



18-3407

KIT REPARACIÓN BOMBA DE AGUA

Reemplaza: 817275A09

Para: 135/150/175 4-tiempos Verado (S/N 1B227000 & Sup),200/225 4-tiempos Verado (S/N OT980000 & Sup), 250/275 4-tiempos Verado (S/N OT801000 & Sup)

APLICACIONES EN LA PÁGINA 58 y 66

① Referencias acabadas en D envasadas



**18-3314
KIT BOMBA DE AGUA**

— CONTIENE —

Ref #	Descripción	O.E. #	Cant.
18-3109	Tubo de agua	23-29804	1
18-3017	Impulsor	47-89984	1
18-3116	Alojamiento	46-96148A1	1
18-3414	Base	46-96146A5	1
18-2919	Junta bomba de agua	27-42631-1	1
18-3110	Casquillo	26-38970	1
18-2945	Junta drenaje	12-20260, 12-19183	2
18-2826	Base alojamiento	27-85610-1	1
18-2914	Junta bomba de agua	27-85608-1	1
18-2915	Junta bomba de agua	27-85609-1	1
18-2944	Retén	26-45577	1
18-3117	Platina	32435	1
18-7158	Aro tórico	25-30613	1
18-7162	Aro tórico	25-33145	1
18-7173	Aro tórico	25-30224	1
18-7176	Aro tórico	25-90011	1
18-2801	Junta	27-32438	1
18-7426	Aro tórico	35-30271	1

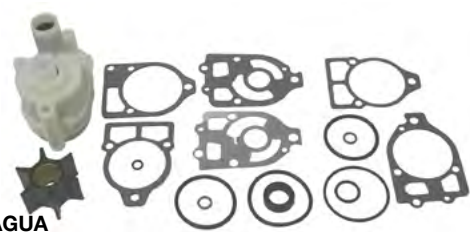

**18-3316
KIT BOMBA DE AGUA**

Reemplaza: 46-78400A2, 46-96148A8, 46-32437A3

— CONTIENE —

Ref #	Descripción	O.E. #	Cant.
18-3109	Tubo de agua	23-29804	1
18-3017	Impulsor	47-89984	1
18-3116	Alojamiento	46-96148A1	1
18-3416	Base	46-96146A6	1
18-2919	Junta bomba de agua	27-42631-1	1
18-3110	Casquillo	26-38970	1
18-2945	Junta drenaje	26-20260, 12-19183	2
18-2826	Base alojamiento	27-85610-1	1
18-2914	Junta bomba de agua	27-85608-1	1
18-2915	Junta bomba de agua	27-85609-1	1
18-2944	Retén	26-45577	1
18-3117	Platina	32435	1
18-7158	Aro tórico	25-30613	1
18-7162	Aro tórico	25-33145	1
18-7173	Aro tórico	25-30224	1
18-7176	Aro tórico	25-90011	1
18-2801	Junta	27-32438	1
18-7196	Aro tórico	25-38099	1
18-7426	Aro tórico	35-30271	1



**18-3319
KIT BOMBA DE AGUA**

Reemplaza: 46-42579A4

— CONTIENE —

Ref #	Descripción	O.E. #	Cant.
18-3109	Tubo de agua	23-29804	1
18-3017	Impulsor	47-89984	1
18-3116	Alojamiento	46-96148A1	1
18-3419	Base	46-42579A3	1
18-2919	Junta bomba de agua	27-42631-1	1
18-3110	Casquillo	26-38970	1
18-2945	Junta drenaje	26-20260, 12-19183	2
18-2826	Base alojamiento	27-85610-1	1
18-2914	Junta bomba de agua	27-85608-1	1
18-2915	Junta bomba de agua	27-85609-1	1
18-2944	Retén	26-45577	1
18-3117	Platina	32435	1
18-7158	Aro tórico	25-30613	1
18-7162	Aro tórico	25-33145	1
18-7173	Aro tórico	25-30224	1
18-7176	Aro tórico	25-90011	1
18-2801	Junta	27-32438	1
18-7426	Aro tórico	35-30271	1



**18-3507
KIT BOMBA DE AGUA**

(Sin base)

Reemplaza: 46-60366A1

— CONTIENE —

Ref #	Descripción	O.E. #	Cant.
18-3007	Impulsor	47-89983	1
18-3118	Alojamiento bomba superior	46-77822A1	1
18-2945	Junta drenaje	12-20260, 12-19183	2
18-2823	Base bomba agua inf. platina	27-32769, 27-19553	1
18-2824	Platina superior a cueroi	27-32770, 27-19551	1
18-2825	Junta bomba de agua	27-32771	1
18-2841	Junta bomba de agua	27-77417, 27-19552	1
18-2948	Tapón drenaje	12-49221-1	1
18-3107	Platina	54705	1
18-7155	Aro tórico	25-26855	1
18-7174	Aro tórico	25-45711	1
18-7115	Aro tórico	25-26722	1



**18-3517
KIT BOMBA DE AGUA**

(sin base)
Reemplaza: 46-96148A5, 46-96148A8, 46-78400A2, 46-73804A3
46-73802A3, 46-69222A3, 46-64141A11, 46-60367A4, 46-58618A4
46-57234A3, 46-48747A3, 46-42579A4, 46-44292A4, 46-32437A1

— CONTIENE —

Ref #	Descripción	O.E. #	Cant.
18-3109	Tubo de agua	23-29804	1
18-3017	Impulsor	47-89984	1
18-3116	Alojamiento	46-96148A1	1
18-2919	Junta bomba de agua	27-42631-1	1
18-3110	Casquillo	26-38970	1
18-2945	Junta drenaje	26-20260, 12-19183	2
18-2826	Base alojamiento	27-85610-1	1
18-2914	Junta bomba de agua	27-85608-1	1
18-2915	Junta bomba de agua	27-85609-1	1
18-2944	Retén	26-45577	1
18-3117	Platina	32435	1
18-7158	Aro tórico	25-30613	1
18-7162	Aro tórico	25-33145	1
18-7173	Aro tórico	25-30224	1
18-7176	Aro tórico	25-90011	1
18-2801	Junta bomba de agua	27-32438	1
18-7426	Aro tórico	35-30271	1



**18-3322
KIT BOMBA DE AGUA**

Reemplaza: 46-77516A3

— CONTIENE —

Ref #	Descripción	O.E. #	Cant.
18-3007	Impulsor	47-89983	1
18-3118	Alojamiento	46-77822A1	1
18-3422	Base bomba de agua	46-77516A1	1
18-2945	Junta drenaje	12-20260, 12-19183	2
18-2823	Base bomba agua inf. platina	27-32769, 27-19553	1
18-2824	Platina superior a cuerpo	27-32770, 27-19551	1
18-2825	Junta bomba de agua	27-32771	1
18-2841	Junta bomba de agua	27-77417, 27-19552	1
18-2948	Tapón drenaje	12-49221-1	1
18-3107	Platina	54705	1
18-7155	Aro tórico	25-26855	1
18-7174	Aro tórico	25-45711	1
18-7115	Aro tórico	25-26722	1

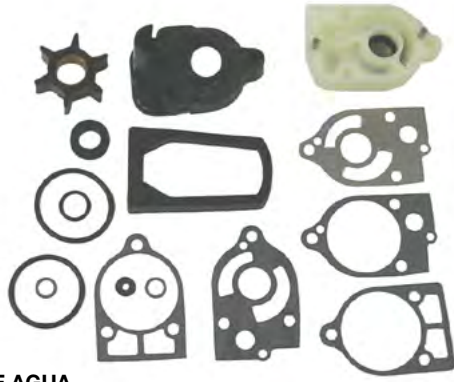

18-3323
KIT BOMBA DE AGUA
Reemplaza: 46-73640A2

— CONTIENE —

Ref #	Descripción	O.E. #	Cant.
18-3007	Impulsor	47-89983	1
18-3118	Alojamiento bomba superior	46-77822A1	1
18-3423	Base bomba de agua	46-73640A1	1
18-2945	Junta drenaje	12-20260, 12-19183	2
18-2823	Base bomba agua inf. platina	27-32769, 27-19553	1
18-2824	Platina superior a cuerpo	27-32770, 27-19551	1
18-2825	Junta bomba de agua	27-32771	1
18-2841	Junta bomba de agua	27-77417, 27-19552	1
18-2948	Tapón drenaje	12-49221-1	1
18-3107	Platina	54705	1
18-7155	Aro tórico	25-26855	1
18-7174	Aro tórico	25-45711	1
18-7115	Aro tórico	25-26722	1



18-3324
KIT BOMBA DE AGUA
Reemplaza: 46-77177A3

— CONTIENE —

Ref #	Descripción.	O.E. #	Cant.
18-3007	Impulsor	47-89983	1
18-3118	Alojamiento bomba superior	46-77822A1	1
18-3424	Base bomba de agua	46-77177A1	1
18-2945	Junta drenaje	12-20260, 12-19183	2
18-2823	Base bomba agua inf. platina	27-32769, 27-19553	1
18-2824	Platina superior a cuerpo	27-32770, 27-19551	1
18-2825	Junta bomba de agua	27-32771	1
18-2841	Junta bomba de agua	27-77417, 27-19552	1
18-2948	Tapón drenaje	12-49221-1	1
18-3107	Platina	54705	1
18-7155	Aro tórico	25-26855	1
18-7174	Aro tórico	25-45711	1
18-7115	Aro tórico	25-26722	1

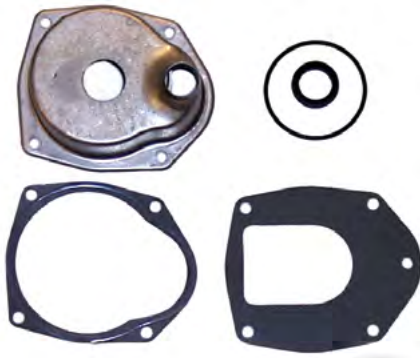

18-3571
KIT ALOJAMIENTO BOMBA
Reemplaza: 817275A1
V-6 fueraborda



18-3572
KIT ALOJAMIENTO BOMBA
Reemplaza: 46-43024A3, 817275A2



18-3148
KIT REPARACIÓN BOMBA DE AGUA
Sin alojamiento
Reemplaza: 46-84277M, 46-84277T

— CONTIENE —

Ref #	Descripción	O.E. #	Cant.
18-0768	Junta disco de desgaste	—	1
18-3074	Impulsor	47-84027M	1
18-3305	Chaveta impulsor	28-8192M	1



18-3446
KIT BOMBA DE AGUA
Reemplaza: 46-70941A3
Para: 4/4.5 HP

— CONTIENE —

Ref #	Descripción	O.E. #	Cant.
18-3039	Impulsor	47-89981	1
18-3139	Impulsor platina	46895	1



18-3448
KIT BOMBA DE AGUA
Reemplaza: 46-48744A3
Para: 20 HP 1967-80

— CONTIENE —

Ref #	Descripción	O.E. #	Cant.
18-3052	Impulsor	47-89982	1
18-2827	Junta platina superior	27-39623	1
18-2828	Junta platina inferior	27-39625	1
18-2829	Junta bomba de agua	27-39626	1



18-4531
KIT REPARACION BOMBA DE AGUA
Sin alojamiento.

Reemplaza: 821354A2. Para: 25 (4-Tiempos), 30 (2 cil.), 30 (4-Tiempos), 40 (2 cil.), 40 (3 cil.), 40 (4-Tiempos), 50 (3 cil.), 50 (4-Tiempos), 50 Bigfoot (4-Tiempos)

— CONTIENE —

Ref #	Descripción	O.E. #	Cant.
18-1838	Reten,corto 1 3/4"	43023	1
18-1839	Reten,largo 2 1/4"	8235471	1
18-2560	Arandela	12-866451	2
18-0345	Junta Superior	27-822189	1
18-99155	Junta inferior	27-822217	1
18-4577	Platina	8213542	1
18-3057	Impulsor	47-850893	1



18-3570
KIT BOMBA DE AGUA

— CONTIENE —

Ref #	Descripción	O.E. #	Cant.
NSS	Alojamiento bomba de agua	—	1
18-3056	Impulsor	47-430262	1
18-2599	Retén	26-816575A2	1
18-3122	Impulsor platina	817276	1

HP	Desde. S/N	Hasta. S/N	HP	Desde. S/N	Hasta. S/N
817275A2 APLICACIÓN					
40 (4 tiempos)			817275A2 APLICACIÓN (Cont.)		
(4 cil.) Bigfoot	OT228405	& Sup	80 Jet	OD283222	& Sup
50 (4 tiempos)			90 (3 cil.)	OA996142	& Sup
935cc Big Foot	OG231123	OT178499	90 (4 tiempos)	OG960500	& Sup
50 (4 tiempos)			100 (4 cil.)	OB209468	& Sup
996cc Big Foot	OT178500	& Sup	115 (4 cil.)	OC100000	& Sup
60 (3 cil.)			125 (4 cil.)	OD283222	& Sup
Bigfoot	OD000750	& Sup	817275A1 APLICACIÓN		
60 (4 tiempos)			45 (4 tiempos)		
Bigfoot	OT178500	& Sup	Bigfoot Bodensee	OG231123	& Sup
65 Jet	OC283222	& Sup	V-200 DFI (3.0L)	OG386496	OG589999
70 (3 cil.)	OA996142	& Sup	V-200 DFI (3.0L)	OG590000	& Sup
75 (3 cil.)	OC222000	& Sup	V-225 (3.0L)		
75 (4 tiempos)	OG960500	& Sup	Carb & EFI	OD280813	& Sup
80 (3 cil.)	OA996142	& Sup	V-225 DFI	OG590000	& Sup
			V-250 (3.0L) EFI	OG129222	& Sup



18-3425
KIT BOMBA DE AGUA
Sin alojamiento

Reemplaza: 84188M, 84188T

— CONTIENE —

Ref #	Descripción	O.E.#	Cant.
18-0292	Junta platina alojamiento	27-81417M	1
18-3435	Tapa	—	1
18-0294	Junta platina alojamiento	—	1
18-3069	Impulsor	47-81423M, 47-97108M	1
18-0256	Tornillo	—	2
18-3436	Impulsor platina	—	1
18-3297	Llave impulsor	—	1



18-3426
KIT BOMBA DE AGUA
Sin alojamiento

Reemplaza: 42431M, 84829M, 97793M, 97793T

— CONTIENE —

Ref #	Descripción	O.E.#	Cant.
18-3067	Impulsor	47-84797M	1
18-3294	Llave impulsor	28-81603M	1

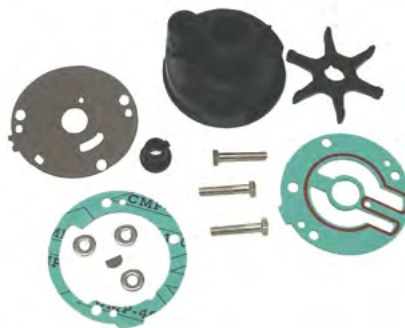

18-3427
KIT BOMBA DE AGUA
Sin alojamiento

Reemplaza: 81242M, 95661M

— CONTIENE —

Ref #	Descripción	O.E.#	Cant.
18-0773	Junta disco desgaste	—	1
18-3067	Impulsor	47-84797M	1
18-3294	Llave impulsor	28-81603M	1



18-48317
KIT COMPLETO BOMBA DE AGUA
Reemplaza: 46-803750A03, 46-80375A03

Para: Mercury 8-9.9 4-tiempos (209c)(R042475 & Sup)

APLICACIÓN SISTEMA REFRIGERACIÓN MARINER

Modelos Mariner	S/N Codigo	S/N	Impulsor	Platina	Tapa impulsor	Kit reparación impulsor	Kit completo
2A	646	Todos	18-3072	—	—	—	—
2B	6A1	Todos	18-3072	—	—	—	—
4A	6E0	Todos	18-3073	—	—	—	—
5C	6E3	Todos	18-3073	—	—	—	—
6C	6H8	Todos	18-3066	—	—	—	—
6D	6H6	Todos	18-3066	—	—	—	—
8A(M)	655	000000-000300	18-3063	—	—	—	—
8A(ML)	655	000000-300101	18-3063	—	—	—	—
8B(M)	677	000101 & Sup	18-3063	—	—	—	—
8B(ML)	677	300101 & Sup	18-3063	—	—	—	—
8C	6G1	Todos	18-3066	—	—	—	—
9.9C	682	Todos	18-3074	—	—	18-3148	—
15A(M)	651	000285 & Inf	18-3063	—	—	—	—
15A(ML)	651	3000100 & Inf	18-3063	—	—	—	—
15C	684	Todos	18-3074	—	—	—	—
20C(M)	6A9	000101-005810	18-3067	18-3436	—	18-3426	—
20C(ML)	6A9	300101-306542	18-3067	18-3436	—	18-3426	—
20C(E)	6A9	250101-250819	18-3067	18-3436	—	18-3426	—
20C(EL)	6A9	550101-550693	18-3067	18-3436	—	18-3426	—
20C(M)	6A9	010112 & Sup	18-3067	—	—	—	18-3427
20C(ML)	6A9	306543 & Sup	18-3067	—	—	—	18-3427
20C(E)	6A9	250820 & Sup	18-3067	—	—	—	18-3427
20C(EL)	6A9	550694 & Sup	18-3067	—	—	—	18-3427
25C(M)	695	000101-014870	18-3067	18-3436	—	—	18-3426
25C(ML)	695	000000-312185	18-3067	18-3436	—	—	18-3426
25C(E)	695	000000-252290	18-3067	18-3436	—	—	18-3426
25C(EL)	695	000000-553575	18-3067	18-3436	—	—	18-3426
25C(M)	695	014871 & Sup	18-3067	—	—	—	18-3427
25C(ML)	695	312186 & Sup	18-3067	—	—	—	18-3427
25C(E)	695	252291 & Sup	18-3067	—	—	—	18-3427
25C(EL)	695	553576 & Sup	18-3067	—	—	—	18-3427
28	664	Todos	18-3067	—	—	—	—
30	689	Todos	18-3067	—	—	—	—
30A(M)	689	000366-014805	18-3067	18-3436	—	—	18-3426
30A(ML)	689	301911-315315	18-3067	18-3436	—	—	18-3426
30A(E)	689	100251-103275	18-3067	18-3436	—	—	18-3426
30A(EL)	689	401216-407815	18-3067	18-3436	—	—	18-3426
30A(M)	689	022059 & Sup	18-3067	—	—	—	18-3427
30A(ML)	689	321377 & Sup	18-3067	—	—	—	18-3427
30A(E)	689	105325 & Sup	18-3067	—	—	—	18-3427
30A(EL)	689	411947 & Sup	18-3067	—	—	—	18-3427
48/48W	670	Todos	18-3069	18-3436	18-3435	18-3425	—
55/W55	663	Todos	18-3069	18-3436	18-3435	18-3425	—
60	675,6F0	Todos	18-3069	18-3436	18-3435	18-3425	—

MERCURY APLICACIONES SISTEMA DE REFRIGERACIÓN

HP	Desde Nº serie	Hasta Nº serie #	Impulsor	Impulsor Platina	Tapa	Aloj. Superior	Base	Kit reparación imp.	Termostato	Kit Superior	Kit Completo
3.3 (con recambio)	D901217	& Sup	18-3098								
3.5	358136	6202172	18-3012								
3.5	6202173	& Sup	18-3054								
3.6	5404657	& Sup	18-3054								
3.9	1655013	2498135	18-3012	18-3139							
4 (1 cil.)	2498136	4107219	18-3039	18-3139				18-3239			
4 (2 cil.)	5589202	& Sup	18-3054	—							
4 (made in USA)	5595532	A809600	18-3054	18-3139							
4 (made in USA)	5595532	& Sup	18-3039	18-3139		18-3446		18-3239			18-3446
4 (1 cil.)	A809601	& Sup	18-3098							—	
4.5	4107220	5595531	18-3039	18-3139				18-3239			18-3446
4.5	5595532	& Sup	18-3054	18-3139							
4.5	5595532	& Sup	18-3039	18-3139				18-3239			18-3446
5	574128	786612	18-3012								
5 (1 cil.)	A809601	& Sup	18-3098								
5 4-tiempos	R000001	& Sup	18-3098								
6	888005	1916138	18-3012								
6	1916139	2193817	18-3039	18-3139				18-3239			
6	A197112	0T800749	18-3062								
6	1582403	1916138	18-3039								
6	1916139	2193817	18-3039								
6	2193818	2529894	18-3039								
6	2385673	2387383	18-3039								
7.5	2529895	4131609	18-3039	18-3139							
7.5	4131610	5226934	18-3039	18-3139				18-3239			18-3446
7.5	5206550	& Sup	18-3054								
7.5	5206550	& Sup	18-3039	18-3139				18-3239			18-3446

- 1 Modelos con alojamiento sup. bomba aluminio
- 2 Modelos con bomba agua aluminio
- 3 Modelos con alojamiento bomba agua plástico
- 4 Modelos con bomba agua plástico
- 5 Bomba tornillos sin aislador
- 6 Bomba tornillos con aislador
- 7 Modelos con tuerca retenedor

- 8 Modelos sin tuerca retenedor
- 9 Modelos con agujero enjuage
- 10 Modelos sin agujero enjuagee
- 11 Modelos con alojamiento superior plástico
- 12 Unidades cambio bomba usando 46-46893A 6 se debe usar 2193818-2529894
- 13 Unidades cambio bomba usando 46-46893A 6 se debe usar USA 3795658-4126549
- 14 Unidades cambio bomba usando 46-46893A 6 se debe usar "Early Mariner Impellers"

APLICACIÓN SISTEMA REFRIGERACIÓN MERCURY

HP	Desde nº Serie #	Hasta nº Serie #	Impulsor	Impulsor Platina	Tapa	Aloj. Superior	Base	Kit repar. Impulsor	Termostato	Kit Superior	Kit Completo
8	A197112	& Sup	18-3062								
8 (4-Tiempos Bodensee)	G760300	& Sup	18-3062								
110 (9.8)	1865779	2196388	18-3039								
110 (9.8)	2196389	3795657	18-3039								
110 (9.8)	3795658	4126459	18-3039								
110 (9.8) 3	4126460	5206549	18-3039	18-3139				18-3239			
110	5206550	& Sup	18-3054								
9.8	5206550	& Sup	18-3039	18-3139				18-3239	18-3553		18-3446
9.9	A197112	& Sup	18-3062								
9.9 (4 tiempos) STANDARD CASE	G760300	T979999	18-3062								
XR10 SeaPro	D038000	& Sup	18-3062						18-3549		
10	500022	1057993	18-3008								
15	B292414	& Sup	18-3062						18-3549		
15 SeaPro	G044365	& Sup	18-3062								
16	700000	& Sup	18-3008								
18	5837437	& Sup	18-3057								
20	860970	1292909	18-3008								
20	2827677	6443972	18-3052								
20	6443973	T800749	18-3057					18-3252			18-3448
22	1158546	1238089	18-3008					18-3215			
25,25XD,25 Sea Pro	5705532	& Sup	18-3057					18-3215			
25 (3 cil.)	E268781	& Sup	18-3057					18-3215			
30	950250	1260724	18-3008								
30	1271884	1448139	18-3007	18-3107				18-3207		18-3507	
30 Jet	C159200	G589999	18-3007	18-3107	18-3115	18-3118	18-3424	18-3207		18-3507	18-3324
30 Jet	G590000	& Sup	18-3057								
30 (2 cil)	G053314	T598999	18-3057								
35	1217222	1448139	18-3007								
35	1571114	1960826	18-3007	18-3107				18-3207		18-3507	
35	1960827	2453068	18-3007	18-3107				18-3207		18-3507	
35	6445653	& Sup	18-3007	18-3107	18-3115	18-3118	18-3424	18-3207		18-3507	18-3324
40	941751	1224480	18-3008								
40	1224481	1476509	18-3007								
40	2874704	4362214	18-3007	18-3107	18-3115	18-3118	18-3422	18-3207		18-3507	18-3322
40 (2 cil) hasta 1983	4860103	& Sup	18-3057	18-3107	18-3115	18-3118	18-3424	18-3207		18-3507	18-3324
40 (3 cil)	G531301	& Sup	18-3057							18-3507	
40 (4 cil)	C159200	& Sup	18-3007	18-3107	18-3115	18-3118	18-3424	18-3207			
40 (4-tiempos) 2:1 ratio	G760300	T408999	18-3057								
40 (EFI 4-tiempos) 1.83:1 ratio	T409000	& Sup	18-8900				18-3445				
40 (EFI 4-tiempos) 2.31:1 ratio	T409000	B344398	18-3056					18-3214			
40 (4-tiempos, 4 cil.) 2.31:1 ratio	T228405	T598999	18-3056					18-3214			
40 (4-tiempos,Std)	G231123	T178499	18-3057								
40 4-tiempos Carb BIG FOOT	C033811	& Sup	18-3056								
40	1279685	1476509	18-3007							18-3507	
45	5531630	& Sup	18-3007	18-3107	18-3115	18-3118	18-3424	18-3207			
45 Jet (3 cil)	D000750	& Sup	18-8900								
45 (4-tiempos,std) Bodensee		G231123 & Sup	18-3057								
45 (4-tiempos,bigfoot) Bodensee	G231123	& Sup	18-3056					18-3214			
50	1421113	1460498	18-3007							18-3507	
50	1477910	1521913	18-3007								
50	1521914	2305100	18-3007	18-3107				18-3207		18-3507	
50 aluminio w/p	2305101	2478119	18-3007								
50 plástico w/p	2305101	2478119	18-3007								
500	2514919	4357639	18-3007	18-3107	18-3115	18-3118	18-3422	18-3207		18-3507	
50 (4cil)	4357640	5531629	18-3007	18-3107	18-3115	18-3118	18-3423	18-3207		18-3507	
50 (4cil)	5531630	& Sup	18-3007			18-3118					
50 (4 cil)	4962056	& Sup	18-3007	18-3107	18-3115	18-3118	18-3424	18-3207		18-3507	
50 (3 cil)	6428681	D000749	18-3007	18-3107	18-3115	18-3118	18-3424	18-3207			
50 (3 cil)	D000750	G589999	18-8900				18-3445		18-3553		
50 (3 cil)	G590000	& Sup	18-3057								
50 (4-tiempos,Std)	G231123	T178499	18-3057								
50 (4-tiempos, 4 cil.) STANDARD	T178500	T598999	18-8900				18-3445				
50 (4-tiempos, 4 cil.) BIG FOOT	T178500	& Sup	18-3056			18-3572		18-3214			
50 (EFI 4-tiempos) STANDARD	T409000	B344398	18-8900				18-3445				
50 (EFI 4-tiempos) BIG FOOT	T409000	B344398	18-3056					18-3214			
55 (3 cil)	D000750	& Sup	18-8900				18-3445				
60	6428681	D000749	18-3007	18-3107	18-3115	18-3118	18-3424	18-3207			18-3324
60 (3cil) standard	D000750	& Sup	18-3056	18-3122				18-3214	18-3553		
60 Marathon	D000750	& Sup	18-3056	18-3122				18-3214			
60 Big Foot	D000750	& Sup	18-3056	18-3122				18-3214	18-3553		
60 (3 cil)	D000750	& Sup	18-8900						18-3553		
60 4-tiempos STANDARD	OT178500	T598999	18-8900				18-3445	18-3214			
60 4-tiempos, BIG FOOT	OT178500	T598999	18-3056					18-3214			
60 4-tiempos EFI BIG FOOT	T409000	B344398	18-3056								

- | | |
|---|---|
| 1 Modelos con alojamiento sup. bomba aluminio | 8 Modelos sin tuerca retenedor |
| 2 Modelos con bomba agua aluminio | 9 Modelos con agujero enjuage |
| 3 Modelos con alojamiento bomba agua plástico | 10 Modelos sin agujero enjuagee |
| 4 Modelos con bomba agua plástico | 11 Modelos con alojamiento superior plástico |
| 5 Bomba tornillos sin aislador | 12 Unidades cambio bomba usando 46-46893A 6 se debe usar 2193818-2529894 |
| 6 Bomba tornillos con aislador | 13 Unidades cambio bomba usando 46-46893A 6 se debe usa USA 3795658-4126549 |
| 7 Modelos con tuerca retenedor | 14 Unidades cambio bomba usando 46-46893A 6 se debe usa "Early Mariner Impellers" |

MERCURY APLICACIONES SISTEMA DE REFRIGERACIÓN

HP	Desde nº Serie #	Hasta nº Serie #	Impulsor	Impulsor Platina	Tapa	Aloj. Superior	Base	Kit repar. Impulsor	Termostato	Kit superior	Kit Completo
65(4 cil) aluminio w/p	1542745	280351	18-3017	18-3117	18-3114			18-3217		18-3507	
65 (4cil) plastico w/p	1542745	280351	18-3017			18-3116					
65 (4cil)	2803562	2874263	18-3017			18-3116					
65 (4cil)	2997439	3293183	18-3017			18-3116					
65(3 cil)	3293184	4382056	18-3007	18-3107	18-3115	18-3118	18-3422	18-3207		18-3507	
65(3 cil)	4382057	4571651	18-3007	18-3107	18-3115	18-3118	18-3424	18-3207			
65 Jet	0D283222	& Sup	18-3056	18-3122				18-3214			
70	1413611	1436114	18-3017	18-3117				18-3217		18-3507	
70 (6cil)	1482212	1503458	18-3017								
700 E-2 (6cil)	1503459	1503958	18-3017								
700 EL-2 (6cil)	1503459	1566239	18-3017								
700 E-2 (6cil)	11 1503959	1566239	18-3017			18-3116					
700 EL-2 (6cil)	11 1505111	1566239	18-3017			18-3116					
70 (3 cil)	4571652	4977156	18-3007	18-3107	18-3115	18-3118	18-3423	18-3207	18-3553	18-3507	
70	4977157	6428680	18-3007	18-3107	18-3115	18-3118	18-3424	18-3207			
70	B110054	& Sup	18-3056					18-3214			18-3517
70 (3cil)	6 A996142	C221999	18-3056			18-3572			18-3553		
70 (3cil)	5 A996142	C221999	18-3056			18-3572			18-3553		
75 (4 cil)	6432901	& Sup	18-3017	18-3117	18-3114	18-3116	18-3414	18-3217			
75 (3 cil)	A996142	C221999	18-3056					18-3214	18-3553		
75 (3 cil)	C222000	& Sup	18-3056					18-3214	18-3569		
75 (3 cil)	C222000	& Sup	18-3056	18-3122				18-3214	18-3569		
75 (3cil) Optimax	T980000	& Sup	18-3056			18-3572					
75 4-Tiempos	G960500	B366822	18-3056					18-3214			
75 4-Tiempos	B366823	& Sup	18-3056			18-3572					
80	1355468	3493912	18-3017	18-3117				18-3217		18-3517	
80 (6cil)	1335465	1398629	18-3017								
80 (4 cil)	4831999	6432900	18-3017	18-3117	18-3114	18-3116	18-3414	18-3217			
80 (3 cil)	6 A996142	C221999	18-3056					18-3214	18-3553		
80 (3 cil)	5 A996142	C221999	18-3056			18-3572			18-3553		
80 Jet	D283222	& Sup	18-3056	18-3122				18-3214			
850 E & EL (6cil)	1460999	1567039	18-3017	18-3117				18-3217		18-3517	
850 E-1, EL-1 (6cil)	11 1566240	1766823	18-3017								
85 (4 cil)	4590512	& Sup	18-3017	18-3117	18-3114	18-3116	18-3414	18-3217			
85 XS (4cil)	3493913	4831998	18-3017			18-3116					
850 XS (4cil)	3493913	4831998	18-3017			18-3116					
850, 850 XS (4cil)	3493913	4590511	18-3017			18-3116					
900 (90hp) (6 cil)	11 1766824	1869775	18-3017	18-3117				18-3217		18-3517	
90 (6 cil)	4845301	& Sup	18-3017	18-3117	18-3114	18-3116	18-3414	18-3217			
90 (3 cil)	B110054	C221999	18-3056					18-3214			
90 (3 cil)	A996142	& Sup	18-3056					18-3214	18-3553		
90 (3 cil)	A996142	& Sup	18-3056	18-3122				18-3214	18-3553		
90 4-Tiempos	G960500	B366822	18-3056			18-3572		18-3214			
90 4-Tiempos	B366823	& Sup	18-3056			18-3572		18-3214			
95	1869776	2318585	18-3017	18-3117				18-3217			
115 (3CIL) Optimax	T801000	& Sup	18-3056			18-3572					
950 (95hp) (6 cil)	11 1869776	2318585	18-3017								
1000(6 cil)	1464949	1503331	18-3017	18-3117				18-3217			
1000 (6cil)	1503332	2318585	18-3017			18-3116					
100 (4 cil)	B209468	& Sup	18-3056					18-3214	18-3553		
100 (4 cil)	B209468	& Sup	18-3056	18-3122				18-3214	18-3553	18-3517	
1000 SS (6cil)	1 2318586	2413843	18-3017			18-3116					
1000 SS (6cil)	3 2318586	2413843	18-3017			18-3116					
1000 SS E-1	1 2484633	2836018	18-3017			18-3116					
1000 SS E-1	3 2484633	2836018	18-3017			18-3116					
1000 BP (6cil)	2399698	3253111	18-3017			N.L.A.					
105 Jet	0D182000	& Sup	18-3017	18-3117	18-3114	18-3116	18-3419	18-3217			
110	1 1870204	2314955	18-3017	18-3117				18-3217			
110	3 1870204	2314955	18-3017			18-3317					
115 (6cil)	2836019	4112634	18-3017	18-3117				18-3217		18-3517	
115 (6cil)	4112635	4394236	18-3017								
115 (6 cil)	4394237	& Sup	18-3017	18-3117	18-3114	18-3116	18-3414	18-3217			
115 (4 cil)	6 C100000	& Sup	18-3056					18-3214	18-3569		
115 (4cil)	5 C100000	& Sup	18-3056			18-3572			18-3569		
115 (4 cil)	B209468	& Sup	18-3056	18-3122				18-3214			
115 4-Tiempos	T178500	B366822	18-3056					18-3214			
115 4-Tiempos	B366823	& Sup	18-3056			18-3572					
115 (3cil) Optimax	T801000	& Sup	18-3056			18-3572					
115 Pro XS	B751825	& Sup	18-3056			18-3572					
125 (6cil)	2 2314956	2839368	18-3017	18-3117				18-3217			
125 (6cil)	4 2314956	2839368	18-3017								
125 (4 cil)	6 D283222	& Sup	18-3056						18-3569		
125 (4cil)	5 D283222	& Sup	18-3056			18-3572					
125 (3cil) Optimax	B736885	& Sup	18-3056			18-3572					

- 1 Modelos con alojamiento sup. bomba aluminio
- 2 Modelos con bomba agua aluminio
- 3 Modelos con alojamiento bomba agua plástico
- 4 Modelos con bomba agua plástico
- 5 Bomba tornillos sin aislador
- 6 Bomba tornillos con aislador
- 7 Modelos con tuerca retenedor

- 8 Modelos sin tuerca retenedor
- 9 Modelos con agujero enjuage
- 10 Modelos sin agujero enjuagee
- 11 Modelos con alojamiento superior plástico
- 12 Unidades cambio bomba usando 46-46893A 6 se debe usar 2193818-2529894
- 13 Unidades cambio bomba usando 46-46893A 6 se debe usar USA 3795658-4126549
- 14 Unidades cambio bomba usando 46-46893A 6 se debe usar "Early Mariner Impellers"

MERCURY APLICACIÓN SISTEMA DE REFRIGERACIÓN

HP	Desde n° Serie #	Hasta n° Serie #	Impulsor	Impulsor Platina	Tapa	Aloj. Superior	Base	Impulsor Repar. kit	Termostato	Kit Superior	Kit completo
135	2839369	3293233	18-3017	18-3117				18-3217			18-3517
V 135	904646	& Sup	18-3017	18-3117	18-3114	18-3116	18-3419	18-3217			—
135 4-tiempos VERADO	B227000	& Sup	18-3056			18-3572					18-3407
140	3293234	3502805	18-3017	18-3117				18-3217			18-3517
140	4865678	& Sup	18-3017	18-3117	18-3114	18-3116	18-3414	18-3217			18-3517
140 Jet	D082000	& Sup	18-3017	18-3117	18-3114	18-3116	18-3419	18-3217			—
150	3502806	4121434	18-3017	18-3117				18-3217			18-3517
150 (6cil) 9	4121435	4865677	18-3017	18-3117	18-3114	18-3116	18-3414	18-3217			18-3517
150 (6cil) 10	4121435	4865677	18-3017				18-3414				
1500 XS (6cil)	4868648	5327662	18-3017								
V 150	A904646	& Sup	18-3017	18-3117	18-3114	18-3116	18-3419	18-3217			18-3517
V 150	A904645	& Inf	18-3017	18-3117	18-3114	18-3116	18-3416	18-3217			18-3517
V-135 DFI	G590000	& Sup	18-3017								
V-150 Carb 8	4868998	A904645	18-3017								
V-150 Carb 7	4868998	A904645	18-3017								
V-150 Carb, EFI, DFI	A904646	& Sup	18-3017								
V-150XR2,4,6 - MAGNUM II, III 8	4868998	& Sup	18-3017								
V150XR2,4,6 - MAGNUM II, III 7	4868998	& Sup	18-3017								
150 4-tiempos VERADO (4cil)	B227000	& Sup	18-3056			18-3572				18-3406	18-3407
V 175	6618751	& Sup	18-3017	18-3117	18-3114	18-3116	18-3419	18-3217			18-3517
V 175	4301235	6618750	18-3017	18-3117	18-3114	18-3116	18-3416	18-3217			18-3517
V-175 Carb, EFI, DFI	6618751	& Sup	18-3017								
175 4-tiempos VERADO (4cil)	B227000	& Sup	18-3056			18-3572				18-3406	18-3407
V 200	6625221	& Sup	18-3017	18-3117	18-3114	18-3116	18-3419	18-3217			18-3517
V-200 8	4839034	6625220	18-3017	18-3117	18-3114	18-3116	18-3416	18-3217			—
V-200 7	4839034	6625220	18-3017								
V-200 DFI (3.0L)	G386496	G589999	18-3056					18-3214			18-3517
V-200 EFI (3.0L)	T750164	B504988	18-3056								
V-200 Carb, & EFI (2.5L)	6625221	& Sup	18-3017								
V-200 DFI (3.0L)	G590000	T598999	18-3056			18-3572					
V-200 DFI (3.0L)	T590000	B504988	18-3056			18-3572					
V-200 DFI (3.0L)	B504989	& Sup	18-3056			18-3572					18-3407
200 4-TIEMPOS VERADO (4cil)	B517159	& Sup	18-3056			18-3572				18-3406	18-3407
200 4-TIEMPOS 4.8 INCH TORPEDO	T980000	& Sup	18-3056			18-3572				18-3406	18-3407
V 220 LASER	B117316	& Sup	18-3017	18-3117	18-3114	18-3116	18-3419	18-3217			18-3517
V-225 (2.4L) 8	5628028	& Sup	18-3017								
V-225 (2.4L) 7	5628028	& Sup	18-3017								
V-225 (3.0L) CARB & EFI	D280813	G760299	18-3056								
V-225 (3.0L) CARB & EFI	G760300	T408999	18-3056			18-3571					
V-225 (3.0L) EFI	T409000	B504988	18-3056			18-3571					
V-225 DFI	G590000	T598999	18-3056			18-3571					
V-225 DFI	T599000	B504988	18-3056			18-3571					
V-225 DFI	B504989	& Sup	18-3056			18-3571					18-3407
V-225 Pro XS	B104549	B752546	18-3056			18-3571					
V-225 Pro XS	B752547	& Sup	18-3056			18-3571					18-3407
225 4-tiempos VERADO 4.8 INCH TORPEDO	T980000	& Sup	18-3056			18-3572					18-3407
V-250 (3.0L) EFI	G129222	T408999	18-3056			18-3571					
V-250 (3.0L) EFI	T409000	B504988	18-3056			18-3572					
V-250 DFI	B528615	& Sup	18-3056			18-3572					18-3407
V-250 Pro XS	B426561	B752546	18-3056			18-3571					
V-250 Pro XS	B752547	& Sup	18-3056			18-3572					18-3407
250 4-tiempos VERADO 4.8 INCH TORPEDO	T980000	& Sup	18-3056			18-3572					18-3407
275 4-tiempos VERADO 4.8 INCH TORPEDO	T980000	& Sup	18-3056			18-3572					18-3407
300 4-tiempos VERADO 4.8 INCH TORPEDO	B517434	& Sup	18-3056			18-3572					18-3407
MARK 5	574128	786612	18-3012								
MARK 6, 6A	888005	& Sup	18-3012								
MARK 50	Todos	& Sup	18-3007								
MARK 55	831021	& Sup	18-3007								
MARK 55A	1227131	& Sup	18-3007								
MARK 58 E, MARK 58A (M&E)	1139538	& Sup	18-3007								
9	0G129222	& Sup	18-3056	18-3117	18-3114	18-3116	18-3419	18-3214			18-3517
XR4/Magnum II	Todos		18-3017					18-3217			

- 1 Modelos con alojamiento sup. bomba aluminio
- 2 Modelos con bomba agua aluminio
- 3 Modelos con alojamiento bomba agua plástico
- 4 Modelos con alojamiento bomba agua plástico
- 5 Bomba tornillos sin aislador
- 6 Bomba tornillos con aislador
- 7 Modelos con tuerca retenedor

- 8 Modelos sin tuerca retenedor
- 9 Modelos con agujero enjuage
- 10 Modelos sin agujero enjuage
- 11 Modelos con alojamiento superior plástico
- 12 Unidades cambio bomba usando 46-46893A 6 se debe usar 2193818-2529894
- 13 Unidades cambio bomba usando 46-46893A 6 se debe usa USA 3795658-4126549
- 14 Unidades cambio bomba usando 46-46893A 6 se debe usa "Early Mariner Impellers"

TODOS LOS PISTONES SE SUMINISTRAN CON LOS AROS, LOS PASADORES Y LAS ARANDELAS



MARINER (MODELOS JAPONESES)
Contenido de los kits de pistones (Ver tabla de aplicaciones por aplicaciones específicas)

Modelo / HP	Cil.	Medida	Pistón	OEM ref #	Aro	OEM ref #
9.9 / 15	2	std	18-4135	761-7982M, 761-7982T, 761-7134M, 761-7133M, 761-7131M	18-3976	39-15320M, 39-15320T
48	2	std	18-4138	761-8484M, 761-7198M, 761-7197M, 761-7196M	—	—

APLICACIONES AROS Y PISTONES MARINER - MODELOS JAPONESES

Modelo	Ser# Codigo	Ser #	Pistón standard	.25mm Pistón	.50mm Pistón	Aros standard	.25mm Aros	.50mm Aros	Cant. Requer
9.9	682	TODOS	18-4135	—	—	18-3976	—	—	2
15C	684	TODOS	18-4135	—	—	18-3976	—	—	2
30A	689	TODOS	18-4138	—	—	—	—	—	2
20C, 25A	6A9	TODOS	-	-	-	-	18-3986	-	2
25C	695	TODOS	-	-	-	-	18-3986	-	2
28	664	TODOS	-	-	-	-	18-3986	-	2
48	670	S-02441 & Up / L33132 & Up					18-3992	-	2
W48	670	M 002731 & Up / ML 314101 & Up					18-3992	-	2
60	675	E 00101-001170 / EL 30101-304180					18-3992	-	2

MERCURY / MARINER

Contenido de los kits de pistones SIERRA (Ver tablas de aplicaciones para aplicaciones específicas)

Modelo / HP	Cil.	Medida	Piston	OEM ref #	Aro	OEM Part #	Arandela	OEM ref#
2 AROS PISTÓN - CÚPULA ALTA								
35-140	2 - 6	2.875 / Std.	—	774-9137A12	18-3918	39-817096A6	18-4294 ④	40-52035
35-140	2 - 6	2.890 / .015	—	774-9137A13	18-3919	39-817096A16	18-4294 ④	40-52035
35-140	2 - 6	2.905 / .030	—	774-9137A14	18-3920	39-817096A26	18-4294 ④	40-52035
2 AROS PISTÓN - CÚPULA BAJA								
35-140	2 - 6	2.875 / Std.	—	774-9137A9	18-3918	39-817096A6	18-4294 ④	40-52035
35-140	2 - 6	2.890 / .015	—	774-9137A10	18-3919	39-817096A16	18-4294 ④	40-52035
35-140	2 - 6	2.905 / .030	—	774-9137A11	18-3920	39-817096A26	18-4294 ④	40-52035
3 AROS PISTÓN - CÚPULA ALTA								
35-140	2 - 6	2.875 / Std.	—	776-8896A3	① 18-3902	39-78816A12, 39-45155A12	18-4294 ④	40-52035
35-140	2 - 6	2.890 / .015	—	776-8897A2	18-3916	39-78811A12, 39-45204A12	18-4294 ④	40-52035
35-140	2 - 6	2.905 / .030	—	776-8898A2	① 18-3917	39-88392A12, 39-88392	18-4294 ④	40-52035
3 AROS PISTÓN - CÚPULA BAJA								
35-140	2 - 6	2.875 / Std.	—	776-8600A9	② 18-3902	39-78816A12	18-4294 ④	40-52035
35-140	2 - 6	2.890 / .015	—	776-9095A1	② 18-3916	39-78811A12, 39-45204A12	18-4294 ④	40-52035
35-140	2 - 6	2.905 / .030	—	776-9096A1	18-3917	39-88392A12, 39-88392	18-4294 ④	40-52035
2 AROS PISTÓN - FLUJO CRUZADO								
40-50	4	2.565 / Std.	18-4620	780-9229A7, 743-5172A6, 743-3193A4, 743-3193A2	18-3966	39-18653A12	18-4294 ④	40-52035
40-50	4	2.580 / .015	18-4621	780-9229A10, 743-3366A2, 743-3366A1	18-3967	39-18653A1	18-4294 ④	40-52035
40-50	4	2.595 / .030	18-4622	780-9229A11, 743-7716A2	18-3968	39-18653A2	18-4294 ④	40-52035
50-60	3	2.875 / Std.	—	783-9613A1	18-4019	39-19721A6	18-4294 ④	40-52035
50-60	3	2.890 / .015	18-4017	783-9613A2, 783-9613T2	—	39-19721A1	18-4294 ④	40-52035
50-60	3	2.905 / .030	18-4018	783-9613A3, 783-9613T3	—	39-19721A2	18-4294 ④	40-52035
70-115	3-4	3.375 / Std.	18-4623	777-815965T4, 777-815965A4	18-3979	39-96170A12	18-4294 ④	40-52035
70-115	3-4	3.390 / .015	18-4624	777-815965A5	—	39-96170A3	18-4294 ④	40-52035
70-115	3-4	3.405 / .030	18-4625	777-815965A6	—	39-96170A4	18-4294 ④	40-52035
75-125	3-4	3.500 / Std.	18-4626	2704-826191T4, 2704-826191A4, 2704-826191A6, 2704-821896A6, 2704-812896A2	18-3982	39-822321A12, 39-824905A12	18-4294 ④	40-52035
75-125	3-4	3.515 / .015	18-4627	2704-821896A3	—	39-822321A1	18-4294 ④	40-52035
75-125	3-4	3.530 / .030	18-4628	2704-821896A4	—	39-822321A2	18-4294 ④	40-52035

APLICACIONES PISTÓN DE 3 AROS EN LÍNEA (SÓLO PARA REFERENCIA ③)

HP	Cil.	Desde n° serie.	Hasta n° serie.	Std. Cil. Dia. (medida)	Std. Pistón	.015 O.S. Pistón	.030 O.S. Pistón	Std. aros	.015 O.S. aros	.030 O.S. aros
3.5	1	6202173	& Sup	2	—	—	—	—	—	—
3.6	1	5404657	& Sup	2	—	—	—	—	—	—
3.9	1	1655013		2	—	—	—	—	—	—

LAS APLICACIONES CONTINÚAN EN LA PÁGINA SIGUIENTE

- ① 3 aros altos NLA, ahora substituidos por aros de pistón ② 3 aros inf. NLA, ahora substituidos por 2 aros pistón
③ La tabla es sólo para referencia, los pistones recibidos serán versión 2 aros
④ Precio por pieza. Para pedir envasado añadir -9 a la referencia..

APLICACIONES PISTÓN DE 3 AROS EN LÍNEA (SÓLO PARA REFERENCIA ☺)

HP	Cil.	Desde n° serie.	Hasta n° serie.	Std. Cil. Dia. (medida)	Std. Pistón	.015 O.S. Pistón	.030 O.S. Pistón	Std. aros	.015 O.S. aros	.030 O.S. aros
4 (1CIL)	1	2498136	A809600	2	—	—	—	—	—	—
4.5	1	4107220	& Sup	2	—	—	—	—	—	—
7.5	2	2529895	& Sup	2	—	—	—	—	—	—
9.8	2	1470349	& Sup	2	—	—	—	—	—	—
20	2	1922910	5942040	2.562	—	—	—	—	—	—
25	2	1467499	149931	2.562	—	—	—	—	—	—
30 Jet (40 HP)	4	0C159200	& Sup	2.562	18-4620	18-4621	18-4622	18-3966	18-3967	18-3968
30 Jet (40 HP)		0C159200	& Sup	2.562	18-4620	18-4621	18-4622	18-3966	18-3967	18-3968
35	2	6445653	& Sup	2.875	—	—	—	18-3918	18-3916	18-3920
40 (4 cil)	4	1279085	1476509	2.562	—	—	—	—	—	—
40	2	2045260	C159199	2.875	—	—	—	18-3918	18-3916	18-3920
40, 402	2	3336258	6445652	2.875	—	—	—	18-3918	18-3916	18-3920
40	4	0C159200	& Sup	2.562	18-4620	18-4621	18-4622	18-3966	18-3967	18-3968
45	4	1476510	& Sup	2.562	18-4620	18-4621	18-4622	18-3966	18-3967	18-3968
45	4	5531630	0B110788	2.562	18-4620	18-4621	18-4622	18-3966	18-3967	18-3968
45	4	0B110789	& Sup	2.562	18-4620	18-4621	18-4622	18-3966	18-3967	18-3968
45 JET	3	D000750	G589999	2.955	—	18-4017	18-4018	18-4019	—	—
50,500	4	2116318	6428680	2.562	18-4620	18-4621	18-4622	18-3966	18-3967	18-3968
50	3	6428681	B122929	2.875	18-4500	—	—	18-3918	18-3916	18-3920
50	3	B122930	D000749	2.875	18-4500	—	—	18-3918	18-3916	18-3920
50	3	D000750	G589999	2.955	—	18-4017	18-4018	18-4019	—	—
55	3	6428681	0B122929	2.875	18-4500	—	—	18-3918	18-3916	18-3920
55	3	B122930	D000749	2.875	18-4500	—	—	18-3918	18-3916	18-3920
55	3	D000750	G589999	2.955	—	18-4017	18-4018	18-4019	—	—
60	6	1303411	1542744	2.562	—	—	—	—	—	—
60	3	6428681	B122929	2.875	—	—	—	18-3918	18-3916	18-3920
60	3	B122930	D000749	2.875	—	—	—	18-3918	18-3916	18-3920
60	3	D000750	G589999	2.955	—	18-4017	18-4018	18-4019	—	—
65,650	3	3293184	4382056	2.875	—	—	—	18-3918	18-3916	18-3920
65,650	3	4382057	4571651	2.875	—	—	—	18-3918	18-3916	18-3920
70	3	4571652	A996141	2.875	—	—	—	18-3918	18-3916	18-3920
70 (3 cil.) w/Rod #646-8188461	3	A996142	& Sup	3.375	18-4623	18-4624	18-4625	18-3979	—	—
75	4	6432901	& Sup	2.875	—	—	—	18-3918	18-3916	18-3920
75 (3 cil.) w/Rod #646-818846	3	C222000	D283221	3.375	18-4623	18-4624	18-4625	18-3979	—	—
75 (3 cil.)	3	D283222	& Sup	3.5	18-4626	18-4627	18-4628	18-3982	—	—
80,800	4	2559001	3493912	2.875	—	—	—	18-3918	18-3916	18-3920
80,800	4	4831999	6432900	2.875	—	—	—	18-3918	18-3916	18-3920
80 Jet	3	D283222	& Sup	3.5	18-4626	18-4627	18-4628	18-3982	—	—
85,850	4	3493913	4831998	2.875	—	—	—	18-3918	18-3916	18-3920
85,850	4	4366802	4831998	2.875	—	—	—	18-3918	18-3916	18-3920
85 Mar.	4	4731898	4842728	2.875	—	—	—	18-3918	18-3916	18-3920
90,900	6	4845301	& Sup	2.875	—	—	—	18-3918	18-3916	18-3920
90 (3 cil.) w/Rod #646-818846	3	A9964142	D283221	3.375	18-4623	18-4624	18-4625	18-3979	—	—
90 (3 cil.)	3	D283222	& Sup	3.5	18-4626	18-4627	18-4628	18-3982	—	—
95	6	1869776	2318585	2.875	—	—	—	18-3918	18-3916	18-3920
100 SS	6	2318586	2836018	2.875	—	—	—	18-3918	18-3916	18-3920
100 BP	6	2399698	3253111	2.875	—	—	—	18-3918	18-3916	18-3920
100 (4 cil.) w/Rod #646-818846	4	B209468	D283221	3.375	18-4623	18-4624	18-4625	18-3979	—	—
100 (4cil)	4	D283222	& Sup	3.5	18-4626	18-4627	18-4628	18-3982	—	—
115 1150	6	2836019	5829643	2.875	—	—	—	18-3918	18-3916	18-3920
115 Merc.	6	5829644	B209467	2.875	18-4500	—	—	18-3918	18-3916	18-3920
115 Mar.	6	5738891	5861526	2.875	—	—	—	18-3918	18-3916	18-3920
115 Mar.	6	5861527	C100000	2.875	18-4500	—	—	18-3918	18-3916	18-3920
115 (4 cil.) w/Rod #646-818846	4	C100000	D283221	3.375	18-4623	18-4624	18-4625	18-3979	—	—
115 (4cil)	4	D283222	& Sup	3.5	18-4626	18-4627	18-4628	18-3982	—	—

APLICACIONES CONTINÚAN EN LA SIGUIENTE PÁGINA

Sistema interno del motor
MERCURY / MARINER

APLICACIONES PISTÓN DE 3 AROS EN LÍNEA (SÓLO PARA REFERENCIA ③)										
HP	Cil.	Desde nº serie.	Hasta nº serie.	Std. Cil. Dia. (medida)	Std. Pistón	.015 O.S. Pistón	.030 O.S. Pistón	Std. aros	.015 O.S. aros	.030 O.S. aros
125 BP	6	2641855	3253111	2.875	—	—	—	18-3918	18-3916	18-3920
135	6	2839369	3293233	2.875	—	—	—	18-3918	18-3916	18-3920
140 1400	6	3293234	3502805	2.875	—	—	—	18-3918	18-3916	18-3920
140 1400	6	4865678	& SUP	2.875	18-4500	—	—	18-3918	18-3916	18-3920
150 1500	6	3502806	5327622	2.875	18-4500	—	—	18-3918	18-3916	18-3920

③ La tabla es sólo para referencia, los pistones recibidos serán versión 2 aros.

PISTONES DE 2 AROS EN LÍNEA & APLICACIONES DE AROS														
HP	Cil.	Desde nº Serie	Hasta nº Serie	Dia. (medida)	Pistones						Piston Aros			
					Std. (babor)	Stbd.	.015" O.S.	Stbd.	.030 O.S.	Stbd.	Std.	.015" O.S.	.030 O.S.	
105 JET	V-6	D082000	& Sup	3.125	—	—	—	—	18-4013	—	—	18-3921	18-3922	18-3923
V-135	V-6	A904646	C239552	3.125	—	—	—	—	—	—	—	18-3921	18-3922	18-3923
V-135 (w/ rod 644-8141)	V-6	C239553	G960499	3.125	—	—	—	—	18-4013	—	—	18-3921	18-3922	18-3923
V-135 (2.5L) (w/o rod 636-818141)	V-6	C239553	G960499	3.125	—	—	—	—	—	—	—	18-3921	18-3922	18-3923
V-140 JET	V-6	D082000	G960499	3.5	18-4635	18-4636	18-4637	18-4638	NA	NA	18-3982	—	—	—
V-140 JET	V-6	G960500	Sup	3.5	18-4635	18-4636	18-4637	18-4638	NA	NA	18-3982	—	—	—
V-150 MAR	V-6	5600162	6038680	3.125	—	—	—	—	—	—	—	18-3921	18-3922	18-3923
V-150 MAR	V-6	6038681	C239552	3.125	—	—	—	—	—	—	—	18-3921	18-3922	18-3923
V-150, 1,501,500	V-6	4868998	6042945	3.125	—	—	—	—	—	—	—	18-3921	18-3922	18-3923
V-150	V-6	6042946	C239552	3.125	—	—	—	—	—	—	—	18-3921	18-3922	18-3923
V-150 (w/ rod 644-8141)	V-6	C239553	G960499	3.125	—	—	—	—	18-4013	—	—	18-3921	18-3922	18-3923
V-150 (2.5L) (w/o rod 636-818141)	V-6	C239553	G960499	3.125	—	—	—	—	—	—	—	18-3921	18-3922	18-3923
V-150 EFI XR6 MAGIII	V-6	D082000	G960499	3.5	18-4635	18-4636	18-4637	18-4638	NA	NA	18-3982	—	—	—
V-150 XR4 MAGIII	V-6	B242885	C239552	3.375	—	—	—	—	18-4570	—	—	18-3924	18-3925	—
V-150 XR4 MAGIII	V-6	C239553	D081999	3.375	—	—	—	—	—	—	—	18-3924	18-3925	—
V-175, 175, 1750	V-6	4301235	6618750	3.125	—	—	—	—	—	—	—	18-3921	18-3922	18-3923
V-175	V-6	6618751	C239552	3.375	—	—	—	—	—	—	—	18-3927 ④	—	—
V-175	V-6	C239553	D081999	3.375	—	—	—	—	—	—	—	18-3924	18-3925	—
V-175	V-6	D082000	G960499	3.5	18-4635	18-4636	18-4637	18-4638	NA	NA	18-3982	—	—	—
V-175	V-6	G960500	& Sup	3.5	18-4635	18-4636	18-4637	18-4638	NA	NA	18-3982	—	—	—
V-175 I XRI EF	V-6	D000750	D081999	3.5	18-4635	18-4636	18-4637	18-4638	NA	NA	18-3982	—	—	—
V-175	V-6	D000750	D081999	3.5	18-4635	18-4636	18-4637	18-4638	NA	NA	18-3982	—	—	—
V-175 XRI EFI	V-6	D082000	G303045	3.5	18-4635	18-4636	18-4637	18-4638	NA	NA	18-3982	—	—	—
V-175 XRI EFI	V-6	G303046	& Sup	3.5	18-4635	18-4636	18-4637	18-4638	NA	NA	18-3982	—	—	—
V-200, 2,002,000	V-6	4839034	6203990	3.375	—	—	—	—	—	—	—	18-3927 ④	—	—
V-200 (2.4L)	V-6	6203991	C291519	3.375	—	—	—	—	—	—	—	18-3927 ④	—	—
V-200 (2.5L) (w/ rod #644-818141)	V-6	C291520	D081999	3.5	18-4635	18-4636	18-4637	18-4638	NA	NA	18-3982	—	—	—
V-200 (2.5L)	V-6	D082000	& Sup	3.5	18-4635	18-4636	18-4637	18-4638	NA	NA	18-3982	—	—	—
V-200 XRI EFI	V-6	C100861	C291519	3.375	—	—	—	—	—	—	—	18-3927 ④	—	—
V-200	V-6	C291520	G960499	3.5	18-4635	18-4636	18-4637	18-4638	NA	NA	18-3982	—	—	—
XRI EFI														
V-220	V-6	B117316	Sup	3.375	—	—	—	—	—	—	—	18-3927 ④	—	—
V-225	V-6	5628028	D280812	3.375	—	—	—	—	—	—	—	18-3927 ④	—	—
V-225 (3.0L)	V-6	D280813	Sup	3.625	—	—	—	—	—	—	—	18-4050	—	—

SIERRA V-6 CONTENIDO KIT PISTÓN (VER TABLA PARA APLICACIONES ESPECIFICAS)

Model / HP	Cil.	Medida	Pistón	OEM port #	Aro pistón	OEM Part #	Pasador	Circlips
135, 150 2 Litros	V-6	3.125 / Std. (babor)	—	765-7442T32	18-3921	39-93481A12	—	N.S.S.
135, 150 2 Litros	V-6	3.125 / Std. (estribor)	—	765-7441T32	18-3921	39-93481A12	—	N.S.S.
135, 150 2 Litros	V-6	3.140 / .015 (babor)	—	765-7444A11	18-3922	39-78918A4	—	N.S.S.
135, 150 2 Litros	V-6	3.140 / .015 (estribor)	18-4013	765-7443A11	18-3922	39-78918A4	—	N.S.S.

4 de — = 1 de 39-21665A12
 4 de 18-3902 = 1 de 39-78816A12
 4 de 18-3916 = 1 de 39-78811A12
 4 de 18-3917 = 1 de 39-88392A12
 3 de 18-3918 = 1 de 39-817096A6

3 de 18-3919 = 1 de 39-817096A16
 3 de 18-3920 = 1 de 39-817096A26
 6 de 18-3921 = 1 de 39-93481A12
 2 de 18-3922 = 1 de 39-78918A4
 2 de 18-3923 = 1 de 39-85636A4

6 de 18-3924 = 1 de 39-18487A12
 2 de 18-3925 = 1 de 39-815267A4
 6 de 18-3966 = 1 de 39-18653A12
 6 de 18-3968 = 1 de 39-18653A2
 6 de 18-3967 = 1 de 39-18653A1

3 de 18-4019 = 1 de 39-19721A6
 6 de 18-3982 = 1 de 39-822321A12
 6 de 18-4050 = 1 de 39-827179A12
 6 de 18-3927 = 1 de 39-813011A12

APLICACIONES CONTINUAN EN LA SIGUIENTE PÁGINA

SIERRA V-6 CONTENIDO KIT PISTÓN (VER TABLA PARA APLICACIONES ESPECÍFICAS)

Model / HP	Cil.	Medida	Pistón	OEM port #	Aro pistón	OEM Part #	Pasador	Circlips
135, 150 2 Litros	V-6	3.155 / .030 (babor)	—	765-7446A11	18-3923	39-85636A4	—	N.S.S.
135, 150 2 Litros	V-6	3.155 / .030 (stbd)	—	765-7445T11	18-3923	39-85636A4	—	N.S.S.
135-175	V-6	3.125 / Std. (babor)	—	765-7442A3, A36	18-3921	39-93481A12	—	N.S.S.
135-175	V-6	3.125 / Std. (stbd)	18-4545	765-7441A3, A36	18-3921	39-93481A12	—	N.S.S.
135-175	V-6	3.140 / .015 (babor)	—	765-7442A2, A12	18-3922	39-78918A4	—	N.S.S.
135-175	V-6	3.140 / .015 (stbd)	—	765-7443A2, A12	18-3922	39-78918A4	—	N.S.S.
135-175	V-6	3.155 / .030 (babor)	—	N/A	18-3923 ④	39-85636A4	—	N.S.S.
135-175	V-6	3.155 / .030 (stbd)	—	N/A	18-3923 ④	39-85636A4	—	N.S.S.
175-225	V-6	3.375 / Std. (babor)	—	766-8667A41/ T41	18-3927 ④	39-813011A12	—	N.S.S.
175-225	V-6	3.375 / Std. (stbd)	—	766-8666A41/ T41	18-3927 ④	39-813011A12	—	N.S.S.
175-225	V-6	3.390 / .015 (babor)	—	766-8667A36/ A43	18-3925	39-815267A4	—	N.S.S.
175-225	V-6	3.390 / .015 (stbd)	—	766-8666A36/ A43	18-3925	39-815267A4	—	N.S.S.
175-225	V-6	3.405 / .030 (babor)	—	NLA	—	NLA	—	N.S.S.
150 XR4/MAG II	V-6	3.375 / Std. (babor)	—	766-8667A42/ T42	18-3924	39-18487A12	—	N.S.S.
150 XR4/MAG II	V-6	3.375 / Std. (stbd)	—	766-8666A42/ T42	18-3924	39-18487A12	—	N.S.S.
150 XR4/MAG II	V-6	3.390 / .015 (babor)	—	766-8667A36/ A43	18-3925	39-815267A4	—	N.S.S.
150 XR4/MAG II	V-6	3.390 / .015 (stbd)	—	766-8666A36/ A43	18-3925	39-815267A4	—	N.S.S.
150 XR4/MAG II	V-6	3.405 / .030 (babor)	—	NLA	—	NLA	—	N.S.S.
140-200, XR6/MAG III	V-6	3.500 / Std. (babor)	18-4635	785-9737T9	18-3982	39-822321A12	—	N.S.S.
140-200, XR6/MAG III	V-6	3.500 / Std. (stbd)	18-4636	785-9738T9	18-3982	39-822321A12	—	N.S.S.
140-200, XR6/MAG III	V-6	3.515 / .015 (babor)	18-4637	785-9737A10	—	39-822321A1	—	N.S.S.
140-200, XR6/MAG III	V-6	3.515 / .015 (stbd)	18-4638	785-9738T10	—	39-822321A1	—	N.S.S.
225 (3.0L)	V-6	3.6265 / Std. (babor)	—	700-858294T1	18-4050	39-827179A12	—	N.S.S.
225 (3.0L)	V-6	3.6265 / Std. (stbd)	—	700-858295T1	18-4050	39-827179A12	—	N.S.S.
225 (3.0L)	V-6	3.6415 / .015 (babor)	—	700-878571A2	—	39-826293A12	—	N.S.S.
225 (3.0L)	V-6	3.6415 / .015 (stbd)	—	700-878572A2	—	39-826293A12	—	N.S.S.
225 (3.0L)	V-6	3.6565 / .030 (babor)	—	700-878573A2	—	39-826297A12	—	N.S.S.
225 (3.0L)	V-6	3.6565 / .030 (stbd)	—	700-878574A2	—	39-826297A12	—	N.S.S.

4 de — = 1 de 39-21665A12
 4 de 18-3902 = 1 de 39-78816A12
 4 de 18-3916 = 1 de 39-78811A12
 4 de 18-3917 = 1 de 39-88392A12
 ④ Para bloques cromados

3 de 18-3918 = 1 de 39-817096A6
 3 de 18-3919 = 1 de 39-817096A16
 3 de 18-3920 = 1 de 39-817096A26
 6 de 18-3921 = 1 de 39-93481A12
 2 de 18-3922 = 1 de 39-78918A4

2 de 18-3923 = 1 de 39-85636A4
 6 de 18-3924 = 1 de 39-18487A12
 2 de 18-3925 = 1 de 39-815267A4
 6 de 18-3966 = 1 de 39-18653A12
 6 de 18-3968 = 1 de 39-18653A2

6 de 18-3967 = 1 de 39-18653A1
 3 de 18-4019 = 1 de 39-19721A6
 6 de 18-3982 = 1 de 39-822321A12
 6 de 18-4050 = 1 de 39-827179A12
 6 de 18-3927 = 1 de 39-813011A12

Env. de 200



AGUJAS COJINETE

Ref #	Reemplaza:	Descripción
18-4036 ①	29-47270	Pistón
18-4037 ①	29-71422	Cojinete central

AGUJAS COJINETE



Ref #	Reemplaza	Descripción
18-4038	31-62596A1, 31-63075A1, 31-61424A2, 31-58859A1, 31-55332A1, 31-47245A1	Cigüeñal sin jaula
18-4039	31-17514A2, 31-8M0045430	Cigüeñal sin jaula

16 agujas-se debe reutilizar la jaula



18-1186
**COJINETE AGUJAS CON
 RETENEDORES**
 Reemplaza: 29-88258 + 12-88263
 (2 piezas)
 Para: Merc V-6 200/225/250 HP 3.0 & 3.4L



18-1194
COJINETE
 Reemplaza: 31-17514A1, 8M004528, 31-17514A2, 31-8M0045428, 31-17514, 31-67526A1, 31-67526A2, 31-67526, 31-821146A1, 31-814337A1, 879366
 Para: 30-60HP 2&3 Cil., Mag II, V-135-200 & XR4



18-1153
COJINETE BOLA
 Reemplaza: 30-63326, 30-63326T, 30-49313, 30-54215, 30-20464



18-1154
COJINETE BOLA
 Reemplaza: 30-63742



18-1196
COJINETE
 Reemplaza: 31-74248T, 31-74248
 Para: V135, 150, 175, 200 (carb)

18-1345
COJINETE BOLA
 Reemplaza: 30-67923T, 30-67923, 30-41421
 Para: 135-225 HP V-6



① Precio por pieza. Para pedir envasado añadir -9 a la referencia.

18-1346
COJINETE BOLA
Reemplaza: 30-43011T, 30-43011
Para: 75-125 3 & 4 cil.



18-1398
COJINETE BOLA
Reemplaza: 30-72961, 30-20861
Para: 3.5-9.8 HP & Mercruiser
Bomba de agua con correa



HP	Cil.	Desde nº de serie.	Hasta nº de serie	std.cil. diámetro	Rodillos	cojinete central	cojinete piston	cojinete principal inferior	Aro inferior	Retén aceite inferior	Retén aceite inferior 2	Aro superior	Cojinete principal superior	Retén aceite superior	cojinete superior
3.5		6202173	& Sup	—	—	—	—	—	—	—	—	18-7152	18-1398	—	—
3.6		5404657	& Sup	—	—	—	—	18-1398	—	—	—	18-7152	18-1398	—	—
3.9	1	1655013	2498135	—	—	—	—	18-1398	—	—	—	18-7152	18-1398	—	—
4 (40)	1	2498136	4107219	—	—	—	—	18-1398	—	—	—	18-7152	18-1398	—	—
4	1	5595532	& Sup	—	—	—	—	18-1398	—	—	—	18-7152	18-1398	—	—
4 (40)	2	5589202	& Sup	—	—	—	—	18-1398	18-7102	—	—	—	—	18-0515	—
4.5 (4.5, 45)	1	4107220	& Sup	—	—	—	—	18-1398	—	—	—	18-7152	18-1398	—	—
4.5	1	5595532	& Sup	—	—	—	—	18-1398	—	—	—	18-7152	18-1398	—	—
6 (60)		1916139	2529894	—	—	—	—	18-1398	—	—	—	18-7459	18-1398	—	—
6		A197112	T800749	—	—	—	—	—	—	—	—	—	—	—	—
7.5 (75)		2529895	5226934	—	—	—	—	18-1398	—	—	—	18-7152	18-1398	—	—
10 (100)		1290910	& Sup	—	—	—	—	—	—	—	—	—	—	—	—
10 (MARATHON, XR10, SEAPRO)		D038000	& Sup	—	—	—	—	—	—	—	—	—	—	—	—
15 (150)		1290910	1499331	—	—	—	—	—	—	18-2026	18-2026	—	18-1153	—	—
15		B292414	& Sup	—	—	—	—	—	—	—	—	—	—	—	—
15 (EXPORT SEAPRO)		G044365	G202749	—	—	—	—	—	—	18-0537	—	—	—	—	—
15 (SEAPRO)		G438000	& Sup	—	—	—	—	—	—	—	—	—	—	—	—
15 (SUPER)		B238464	G202749	—	—	—	—	—	—	18-0537	—	—	—	—	—
18		5837437	6239752	—	—	—	—	—	—	18-0537	—	—	—	—	—
20		1558310	2296266	—	—	—	—	—	—	18-2026	18-2026	—	18-1153	—	—
20 (200, 20)		2296267	& Sup	—	—	—	—	—	—	—	—	—	—	—	—
25 (KF 9)	4	377150	495761	—	—	—	—	—	—	—	—	—	—	—	—
10 (MK10)	2	1057994	1122327	—	—	—	—	—	—	—	—	—	—	—	—
15 (MK15)	2	1200114	1287384	—	—	—	—	—	—	—	—	—	—	—	—
16 (MK20)	2		Todos	—	—	—	—	—	—	—	—	—	—	—	—
20 (MK25)	2	860979	& Sup	—	—	—	—	—	—	—	—	—	—	—	—
22 (MK28)	2	1158546	1238089	—	—	—	—	—	—	—	—	—	—	—	—
30 (MK30)	4		Todos	—	—	—	—	—	—	—	—	—	—	—	—
35 (MK35)	4	1217222	1271884	—	—	—	—	—	—	—	—	—	—	—	—
25 (MK40)	4	711400	& Sup	—	—	—	—	—	—	—	—	—	—	—	—
40 (MK50)	4		Todos	—	—	—	—	—	—	—	—	—	—	—	—
40(MK55)	4	831021	& Sup	—	—	—	—	—	—	—	—	—	—	—	—
45 (MK58)	4	1139538	& Sup	—	—	—	—	—	—	—	—	—	—	—	—
60 (MK75)	6		Todos	18-4037	—	—	—	—	—	—	—	—	—	—	—
70 (MK78)	6	1143038	& Sup	18-4037	—	—	—	—	—	—	—	—	—	—	—
3.5 / 3.6 / 3.9	1		Todos	—	—	—	—	18-1398	—	—	—	—	18-1398	—	—
9.8	2	1865779	& Sup	—	—	—	—	18-1398	—	—	—	—	18-1398	—	—
20	2	1292910	6443972	—	—	—	—	18-1153	—	—	—	—	18-1153	—	—
20 (20 XD)	2	6443973	B114230	—	—	—	—	—	—	18-0537	—	—	—	—	—
25	2	1467499	1499331	—	—	—	—	—	—	—	—	—	—	—	—
25	2	5705532	6241936	—	—	—	—	—	—	18-0537	—	—	—	—	—
25 (250)		1290910	1499331	—	—	—	—	—	—	—	—	—	—	—	—
30 (300)	4	1271885	1448139	—	—	—	—	18-1154	18-7151	—	18-2016	18-7151	18-1154	—	—
30 (644cc)	2	G053314	D589999	—	18-4039	—	18-4036	18-1154	18-7176	18-2016	—	—	—	—	—
30 (644cc)	2	G590000	T598999	—	18-1194	—	18-4036	—	—	—	—	—	—	—	—

APLICACIÓN CONTINUÁN EN LA SIGUIENTE PÁGINA

HP	Cil.	Desde nº de serie.	Hasta nº de serie	std.cil. diámetro	Rodillos	cojinete central	cojinete pistón	cojinete principal inferior	Aro inferior	Retén aceite inferior	Retén aceite inferior 2	Aro superior	Cojinete principal superior	Retén aceite superior	cojinete superior
30 JET	4	C159200	& Sup	18-4037	—	—	—	18-1154	—	—	—	—	18-1154	—	—
30 JET	3	G590000	& Sup	—	—	—	18-4036	18-1154	—	—	—	—	—	—	—
35 (350, 35A)	4	121722	1448139	—	—	—	—	18-1154	—	—	—	—	18-1154	—	—
35 (350)	2	1571114	1898815	—	—	—	—	18-1154	18-7151	—	—	—	18-1154	—	—
35	2	6445653	B110788	—	—	18-4038	—	18-4036	18-1154	—	—	—	—	—	—
40 (400E, 400M)	4	1279685	1367697	—	—	—	—	18-1154	—	—	—	—	18-1154	—	—
40 (400E, 400M)	4	1384806	1476509	—	—	—	—	—	—	—	—	—	—	—	—
40 (400)	2	2874704	3045259	—	—	18-4038	—	18-4036	18-1154	18-2016	18-2016	—	18-2016	—	—
40 (400)	2	3045260	3336257	—	—	18-4038	—	18-4036	—	—	—	—	—	—	—
40 (402)		3336258	4117709	—	—	18-4038	—	18-4036	—	—	—	—	—	—	—
40 (402, 40)		4117710	5556229	—	—	18-4038	—	18-4036	—	18-2016	18-2016	—	18-2016	—	—
40	2	5556230	6443972	—	—	18-4038	—	18-4036	—	—	—	—	—	—	—
40	2	G053314	& Sup	—	—	18-1194	—	18-4036	18-1154	18-2016	—	—	—	—	—
40	3	G531301	& Sup	—	—	18-1194	—	18-4036	18-1154	18-2016	—	—	—	—	—
40	4	C159200	& Sup	18-4037	—	—	—	18-1154	18-7161	18-2016	—	18-7151	18-1154	—	—
45 (450)	4	1476510	1531568	—	—	—	—	18-1154	—	18-2016	18-7151	18-1154	18-1154	—	—
45	4	5531630	& Sup	18-4037	—	—	—	18-1154	18-7151	18-2016	18-7151	18-1154	18-1154	—	—
45 JET		D000750	D589999	—	—	18-4039	—	18-4036	18-1154	18-7176	18-2016	—	—	18-2016	—
45 JET (59 CID)	3	G590000	& Sup	—	—	18-1194	—	18-4036	18-1154	18-7176	18-2016	—	—	—	—
50 (500)	4	1421113	1755548	—	—	—	—	18-1154	18-7151	—	18-2016	18-7151	18-1154	18-2016	—
50 (500)		1770179	2305100	—	—	—	—	—	—	—	—	—	—	—	—
50 (500, 50)		2305151	5193253	—	—	—	—	—	—	—	—	—	—	—	—
50	4	5193259	5531629	18-4037	—	—	—	18-1154	—	—	—	—	18-1154	—	—
50	4	5531630	& Sup	18-4037	—	—	—	—	—	—	—	—	—	—	—
50	3	6428681	D000749	18-4037	18-4038	—	18-4036	—	18-7161	18-2016	18-2016	18-7415	—	18-2016	—
50	3	D000750	G589999	—	18-4039	—	18-4036	18-1154	18-7176	18-2016	—	—	—	18-2016	—
50	3	G590000	& Sup	—	18-1194	—	18-4036	18-1154	18-7176	18-2016	—	—	—	—	—
55	3	D000750	G589999	—	18-4039	—	18-4036	18-1154	18-7176	18-2016	—	—	—	18-2016	—
55	3	G590000	& Sup	—	18-1194	—	18-4036	18-1154	18-7176	18-2016	—	—	—	—	—
60 (600)	4	1303411	1542744	18-4037	—	—	—	18-1154	18-7151	—	18-2016	18-7151	18-1154	18-2016	—
60	3	6428681	D000749	18-4037	18-4038	—	18-4036	—	18-7161	18-2016	18-2016	18-7415	—	18-2016	—
60	3	D000750	G589999	—	18-4038	—	18-4036	18-1154	18-7176	18-2016	—	—	—	18-2016	—
60 (59 CID)	3	G590000	& Sup	—	18-1194	—	18-4036	18-1154	—	—	—	—	—	—	—
65 (650)	4	1545745	1765043	18-4037	—	—	—	18-1154	18-7151	—	18-2016	—	—	18-2016	—
65 (650)	4	1765044	2119748	18-4037	—	—	—	—	—	—	—	—	—	—	—
65 (650)	4	2119749	2309310	18-4034	—	—	—	—	—	—	—	—	—	—	—
65 (650)	4	2309311	3293183	18-4037	—	—	—	—	—	—	—	—	—	—	—
65 (650)	3	3293184	4571651	18-4037	18-4038	—	18-4036	—	18-7161	18-2016	18-2016	18-7961	—	18-2016	—
65 (650)	3	8006640	8042349	18-4037	18-4038	—	18-4036	—	—	—	—	—	—	—	—
65 (650)	3	9020074	9135824	18-4037	18-4038	—	18-4036	—	—	—	—	—	—	—	—
65 (650)	3	7013633	7087822	18-4037	18-4038	—	18-4036	—	—	—	—	—	—	—	—
65 JET		D283222	& Sup	—	—	—	—	18-1346	—	18-2016	—	18-7414	—	18-0523	—
70 (700)	6	1296411	1566239	18-4037	—	—	—	18-1154	18-7151	—	18-2016	18-7151	18-1154	18-2016	—
70	3	4571652	5579016	18-4037	18-4038	—	18-4036	—	18-7161	18-2016	18-2016	18-7415	—	18-2016	—
70	3	5579017	6428680	18-4037	18-4038	—	18-4036	—	—	—	—	—	—	—	—
70 CONNECTING ROD #638-8532-1	3	A996142	C221999	—	—	—	—	18-1346	—	18-2016	—	18-7414	—	18-0523	—
75	4	6432901	& Sup	18-4037	18-4038	—	18-4036	18-1154	18-7161	18-2016	18-2016	18-7961	—	18-2016	—
75 CONNECTING ROD #638-8532-1	3	C222000	& Sup	—	—	—	—	18-1346	—	18-2016	—	18-7414	—	18-0523	—
75 DFI (1.5L)		T980000	B189548	—	—	—	—	18-1346	—	18-2016	—	—	—	—	—
80 (800)	6	1335465	1566239	18-4037	—	—	—	18-1154	18-7151	—	18-2016	18-7151	18-1154	18-2016	—
80 (800)	4	2559001	2670574	18-4037	18-4038	—	18-4036	18-1154	18-2016	18-2016	18-2016	18-7961	—	18-2016	—

APLICACIÓN CONTINÚAN EN LA SIGUIENTE PÁGINA

HP	Cil.	Desde n° de serie.	Hasta n° de serie	std.cil. diámetro	Rodillos	cojinete central	cojinete pistón	cojinete principal inferior	Aro inferior	Retén aceite inferior	Retén aceite inferior 2	Aro superior	Cojinete principal superior	Retén aceite superior	cojinete superior
80 (800)	4	2783253	3493912	18-4037	18-4038	—	18-4036	—	—	—	—	—	—	—	—
80 (800, 80)	4	4831999	5582561	18-4037	18-4038	—	18-4036	18-1154	18-7161	18-2016	18-2016	18-7961	—	18-2016	—
80 (80)	4	5582562	6422900	18-4037	18-4038	—	18-4036	—	—	—	—	—	—	—	—
80 CONNECTING ROD #638-8532-1	3	A996142	C221999	—	—	—	—	18-1346	—	18-2016	—	18-7414	—	18-0523	—
80 JET		D283222	& Sup	—	—	—	—	18-1346	—	18-2016	—	18-7414	—	18-0523	—
85 (850, 76 CID)	6	1460999	1464848	18-4037	—	—	—	18-1154	18-7151	—	18-2016	18-2016	—	18-2016	—
85 (850, 90 CID)	6	1566240	1766823	18-4037	—	—	—	18-1345	18-2016	—	18-2016	—	—	18-2016	—
85 (850)	4	3493913	3865694	18-4037	18-4038	—	18-4036	18-1154	18-7161	18-2016	18-2016	18-7961	—	18-2016	—
85 (850)	4	3865695	4831998	18-4037	18-4038	—	18-4036	—	—	—	—	—	—	—	—
90 (900)	6	1766824	1850448	18-4037	—	—	—	18-1154	18-2016	—	18-2016	—	—	18-2016	—
90 (900)	6	1850449	1869775	18-4037	—	—	—	—	—	—	—	—	—	—	—
90 (900, 90)	6	4845301	5594656	18-4037	18-4038	—	18-4036	18-1154	18-7161	18-2016	18-2016	—	—	18-2016	—
90 (90)	6	5594657	& Sup	18-4037	18-4038	—	18-4036	—	—	—	—	—	—	—	—
90 (90) CONNECTING ROD #638-8532-1	3	A996142	D283221	—	—	—	—	18-1346	—	18-2016	—	18-7414	—	18-0523	—
95 (950E)	6	1869776	2318585	18-4037	—	—	—	18-1154	18-7151	—	18-2016	—	—	18-2016	—
95 (950E-SS)		1869776	2318585	18-4037	—	—	—	18-1154	18-2016	—	18-2016	—	—	18-2016	—
95 (950E-SS-1)		1869776	2318585	18-4037	—	—	—	—	—	—	—	—	—	—	—
100 (1000)	6	1464949	2318585	18-4037	—	—	—	18-1154	18-7151	—	18-2016	—	—	18-2016	—
100 (1000SS)		2318586	2836018	18-4037	—	—	—	18-1154	18-7151	—	18-2016	—	—	18-2016	—
100 (1000BP)		2399698	2641854	18-4037	—	—	—	—	—	—	—	—	—	—	—
100 (1000BP)		2641855	3253111	18-4037	18-4038	—	18-4036	18-1154	18-7151	18-2016	18-2016	18-7961	—	18-2016	—
100	4	B209468	& Sup	—	—	—	—	18-1346	—	—	—	—	—	—	—
105 JET		D820000	& Sup	—	18-1194	—	—	18-1345	—	—	—	—	—	—	—
110 (1100E)		1870204	2314955	18-4037	—	—	—	18-1154	18-7151	—	18-2016	—	—	18-2016	—
110 (1100-SS)	6	1870204	2314955	18-4037	—	—	—	18-1154	18-2016	—	18-2016	—	—	18-2016	—
110 (1100E-SS-1)	6	1870204	2314955	18-4037	—	—	—	—	—	—	—	—	—	—	—
115 (1150)	6	2836019	3525440	18-4037	18-4038	—	18-4036	18-1154	18-7151	18-2016	18-2016	18-7961	—	18-2016	—
115 (1150, 115)		3525441	5600966	18-4037	18-4038	—	18-4036	—	—	—	—	—	—	—	—
115	6	5600967	6262960	18-4037	18-4038	—	18-4036	—	—	—	—	—	—	—	—
115	6	6262961	C099999	18-4037	18-4038	—	18-4036	—	—	—	—	—	—	—	—
115 CONNECTING ROD #638-8532-1	4	C100000	D283221	—	—	—	—	18-1346	—	18-2016	—	18-7414	—	18-0523	—
115 OPTIMAX	6	G960500	T178499	—	18-1194	—	—	—	—	—	—	—	—	—	—
125 (1250, 1250BP)	6	2314956	2641954	18-4037	18-4038	—	18-4036	18-1154	18-2016	—	—	18-7961	—	18-2016	—
125 (1250BP)		2641955	3253111	18-4037	18-4038	—	—	—	—	—	—	—	—	—	—
125	4	D283222	& Sup	—	—	—	—	18-1346	—	18-2016	—	18-7414	—	18-0523	—
135 (1350)		2839369	3293233	18-4037	18-4038	—	18-4036	18-1154	18-7151	18-2016	18-2016	18-7961	—	18-2016	—
1400		3293234	3502805	18-4037	18-4038	—	18-4036	18-1154	—	—	—	—	—	—	—
1400-140		4865678	& Sup	18-4037	18-4038	—	18-4036	—	—	—	—	—	—	—	—
140 JET	V-6	D082000	& Sup	—	18-4039	—	—	18-1345	18-0860	18-2016	18-2016	18-0858	—	18-2016	—
V-135 W/ METAL CAGED MAIN BRG	V-6	A904646	C239552	—	18-1194	—	—	—	—	—	—	—	—	—	—
V-135 W/ PLASTIC CAGED MAIN BRG	V-6	A904646	C239552	—	18-1194	—	—	—	—	—	—	—	—	—	—
V-135 CONNECTING ROD #636-8118	V-6	C239553	D082000	—	18-1194	—	—	—	—	—	—	—	—	—	—
V-135	V-6	D082000	& Sup	—	18-1194	—	—	—	—	—	—	—	—	—	—
V-135 DFI	V-6	D082000	G760299	—	18-4039	—	—	18-1345	—	—	—	—	—	—	—

APLICACIONES CONTINÚAN EN LA SIGUIENTE PÁGINA

HP	Cil.	Desde nº de serie.	Hasta nº de serie	std.cil. diámetro	Rodillos	cojinete central	cojinete piston	cojinete principal inferior	Aro inferior	Retén aceite inferior	Retén aceite inferior 2	Aro superior	Cojinete principal superior	Retén aceite superior	cojinete superior
V-135 DFI	V-6	G760300	& Sup	—	18-1194	—	—	—	—	—	—	—	—	—	—
1500-1500XS	V-6	3502806	5327662	18-4037	18-4038	—	18-4036	18-1154	18-7161	18-2016	18-2016	18-7961	—	18-2016	—
1500-1500XS	V-6	8005615	8052649	18-4037	18-4038	—	18-4036	—	—	—	—	—	—	—	—
1500-1500XS	V-6	7010533	7112772	18-4037	18-4038	—	18-4036	—	—	—	—	—	—	—	—
V-150 (V-1500)	V-6	4868998	C100860	—	18-4039	—	—	18-1345	—	18-2016	18-2016	—	—	18-2016	18-1196
V-150	V-6	C100861	C239552	—	18-1194	—	—	18-1345	18-0860	18-2016	18-2016	18-0858	—	18-2016	—
V-150 CONNECTING ROD #636-8118	V-6	C239553	D081999	—	18-1194	—	—	18-1345	18-0860	18-2016	18-2016	18-0858	—	18-2016	—
V-150 CONNECTING ROD #644-818141	V-6	C239553	D081999	—	18-1194	—	—	—	—	—	—	—	—	—	—
V-150 DFI	V-6	D082000	& Sup	—	18-1194	—	—	18-1345	18-0860	18-2016	18-2016	18-0858	—	18-2016	—
V-150 EFI	V-6	D082000	& Sup	—	18-4039	—	—	18-1345	—	—	—	—	—	—	—
150	V-6	4868998	D081999	—	18-1194	—	—	—	—	—	—	—	—	—	—
XR-4	V-6	G760300	& Sup	—	18-1194	—	—	—	—	—	—	—	—	—	—
XR-4	V-6	B242885	C239552	—	18-1194	—	—	—	—	—	—	—	—	—	—
XR-4	V-6	C239553	D081999	—	18-1194	—	—	—	—	—	—	—	—	—	—
XR-6	V-6	D082000	& Sup	—	18-4039	—	—	18-1345	—	—	—	—	—	—	—
V-175 (1750)	V-6	4301235	6618750	—	18-4039	—	—	18-1345	—	18-2016	18-2016	—	—	18-2016	18-1196
V-175	V-6	6618751	C239552	—	18-1194	—	—	18-1345	18-0860	18-2016	18-2016	18-0858	—	18-2016	—
V-175	V-6	C239553	D081999	—	18-1194	—	—	18-1345	18-0860	18-2016	18-2016	18-0858	—	18-2016	—
V-175	V-6	D082000	& Sup	—	18-1194	—	—	—	—	—	—	—	—	—	—
V-175 XRI	V-6	D000750	D081999	—	18-1194	—	—	18-1345	18-0860	18-2016	18-2016	18-0858	—	18-2016	—
V-175 EFI	V-6	D082000	& Sup	—	18-4039	—	—	18-1345	—	—	—	—	—	—	—
V-175	V-6	T178500	& Sup	—	18-1194	—	—	18-1345	18-0860	18-2016	18-2016	18-0858	—	18-2016	—
DFI & PRO XS															
175 (1750)	V-6	8058870	& Sup	—	18-1194	—	—	—	—	—	—	—	—	—	—
V-200 (V2000)	V-6	4839034	5363917	—	18-1194	—	—	18-1345	—	—	—	—	—	—	—
V-200 (V2000)	V-6	5363918	6073191	—	18-1194	—	—	18-1345	—	18-2016	18-2016	—	—	18-2016	18-1196
V-200 (2.4L)	V-6	6073192	C291519	—	18-1194	—	—	18-1345	18-0860	18-2016	18-2016	18-0858	—	18-2016	—
V-200 (2.5L) CONNECTING ROD #636-8118	V-6	C291520	D081999	—	18-1194	—	—	—	—	—	—	—	—	—	—
V-200 (2.5L) CONNECTING ROD #644-818141	V-6	C291520	D081999	—	18-1194	—	—	—	—	—	—	—	—	—	—
V-200	V-6	D082000	& Sup	—	18-4039	—	—	18-1345	—	—	—	—	—	—	—
V-200 EFI	V-6	C100861	C291519	—	18-1194	—	—	18-1345	18-0860	18-2016	18-2016	18-0858	—	18-2016	—
V-200 EFI CONNECTING ROD #644-818141	V-6	C291520	D081999	—	18-1194	—	—	—	—	—	—	—	—	—	—
V-200 EFI CONNECTING ROD #636-8118	V-6	C291520	D081999	—	18-1194	—	—	—	—	—	—	—	—	—	—
V-200 EFI (2.5L)	V-6	D082000	B226999	—	18-4039	—	—	18-1345	—	—	—	—	—	—	—
V-220	V-6	B117316	& Sup	—	18-1194	—	—	—	—	—	—	—	—	—	—
V-225	V-6	5628028	D280812	—	18-1194	—	—	18-1345	18-0860	18-2016	18-2016	—	—	18-2016	—
V-225 (225, SEAPRO)	V-6	D280813	& Sup	—	18-4039	—	—	18-1345	—	—	—	—	—	—	—
V-225 DFI	V-6	G590000	T325116	—	—	—	—	18-1345	18-0860	—	—	18-7414	—	—	—
V-225	V-6	G129222	& Sup	—	—	—	—	18-1345	18-0860	—	—	18-7414	—	—	—
V-250 EFI	V-6	G129222	T325116	—	—	—	—	18-1345	18-0860	—	—	18-7414	—	—	—
V-250	V-6	C101891	& Sup	—	18-4039	—	—	18-1345	—	—	—	18-7414	—	18-2016	—
V-250 DFI & PRO XS	V-6	B528615	& Sup	—	—	—	—	18-1345	18-0860	—	—	18-7414	—	—	—
V-275	V-6	C101891	& Sup	—	—	—	—	—	—	—	—	18-7414	—	—	—
V-3.4L	V-6	5611648	& Sup	—	18-4039	—	—	18-1345	—	—	—	18-7414	—	—	—

 <p>18-2143 KIT SILENT BLOCK Reemplaza: 67210, 78249 Diámetro largo Montaje parte inferior Incluye: (1) monta jde de parte inferior y (2) 1 1/4" D.E. x 1/2" D.I. arandelas de acero inoxidable.</p>	 <p>18-2144 KIT SILENT BLOCK Reemplaza: 67209, 77326, 78687, 78687T Diámetro corto Montaje superior Incluye: (1) Montaje parte superior y (1) 1 1/4" D.E. x 1/2" D.I. Arandelas de acero inoxidable</p>	 <p>18-7901 FILTRO ACEITE Reemplaza: 825467A1, T1 Para: 9.9HP S/N OH000058-OH017099 (1995-98)</p>	 <p>18-7758 187758E Easterner FILTRO ACEITE Reemplaza: 35-877761K01, 35-877761Q01 Para: 75/90/115 hp. (S/N 1B366823 (2006) & Sup)</p>
--	---	---	---

 <p>18-7918 187918E Easterner FILTRO ACEITE Reemplaza: 35-883701K01, 35-877769K01 Desde: Verado 200-300 HP, En línea 6 cilindros</p>	 <p>18-7921 187921E Easterner FILTRO ACEITE Reemplaza: 35-896546T, 35-877767K01 Para: Verado 135-200 HP, En línea 4 cilindros</p>	 <p>18-7906 187906E Easterner FILTRO ACEITE Reemplaza: 35-822626T7, 35-822626Q15, 35-8226267 Para: 225 HP (No-Verado)</p>
--	---	---

 <p>18-7913 187931E Easterner FILTRO ACEITE Reemplaza: 35-822626Q1 Para: 8 HP (323cc) 2001-2004 / 9.9 HP (323cc) 1999-2004 / 15 HP. (323cc) 1998 y posteriores / 20 HP. 2008 y posteriores / 30 HP (492cc) 2006 y posteriores</p>	 <p>18-7914 187914E Easterner FILTRO ACEITE Reemplaza: 35-822626Q2, 35-822626Q04, 35-877768K01, 35-822626K04, 35-822626T2, 35-8M0064104, 35-8M0008397 Para: 25 HP. (498cc) 1998-2005 / 30 HP. (747cc) 1999-2005 / 40, 50, 60 HP. 1995 y posteriores / 75, 90 Carburado 2000-2005 / 115 EFI (S/N 1B366822 y inferior)</p>	 <p>18-0663 KIT JUNTA Para: Mercury 75 4-tiempos (2000-03), 90 4-tiempos (2000 & Sup),</p>
--	---	--



CORREAS

Referencia	Reemplaza	Para
18-15146	8M0072670	25HP EFI (3 cil) 4 Tiempos OR106999 y anteriores; 25HP JET EFI (3 cil) OR165086 y anteriores; 30HP EFI (3 cil) 4 tiempos OR106999 y anteriores
18-15147	835392Q	9.9HP 4 tiempos OG760300-1B226999; 15HP 4 tiempos 1B227000-1B727495; 15HP 4 tiempos OG760300-1B226999
18-15148	8M0065179	40HP (3 cil) 4 tiempos 1C049739 y anteriores; 40-50-60HP 4 tiempos 1C050252 y anteriores
18-15149	57-895120	8HP 4 tiempos OR042475 y anteriores; 9.9HP 4 tiempos OR042475 y anteriores
18-15150	57-895120002	10HP Carb (2 cil.) 4 tiempos OR575531-OR833819; 15HP Carb (2 cil.) 4 tiempos OR235949-OR833819; 15HP Carb 4 tiempos JCI OR558208-OR833819; 15HP SEAPRO 4 tiempos OR051685-OR123564; 15HP SEAPRO 4 tiempos OR123565 y anteriores; 20HP carb (2 cil.) 4 tiempos OR235168-OR833819

— CONTIENE —

Ref #	Descripción	O.E.#	Cant.
18-2506-1	Junta platina escape	27-99176-3	1
18-0860	Aro	25-62700	1
18-0858	Aro	25-54029	1
18-0182	Junta termostato	27-62386	2
18-0642	Junta platina divisoria	27-19050-3	1
18-2735	Junta platina divisoria	27-190506	1
18-0936	Junta	27-78690	2
18-2511	Junta	27-99173-2	1
18-0643	Junta base bloque	27-183071	1
18-2919	Junta	27-42631-1	1
18-7176	Aro	25-90011	1
18-2914	Junta bomba agua	27-85608-1	1
18-2915	Junta bomba agua	27-85609-1	1
18-7159	Aro	25-31534	1
18-7153	Aro	27-25439	1
18-7174	Aro	25-45711	2
18-0970	Junta bomba combustible	27-98769-1	1
18-0135	Junta tapa	27-78246	1
18-2514	Junta	27-53650	2

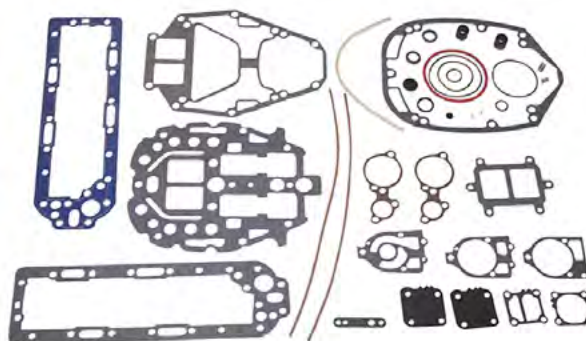

18-4338
JUEGO JUNTAS BLOQUE
Reemplaza: 27-814754A00.
Para: V-135,V-150 fuerabordas DFI

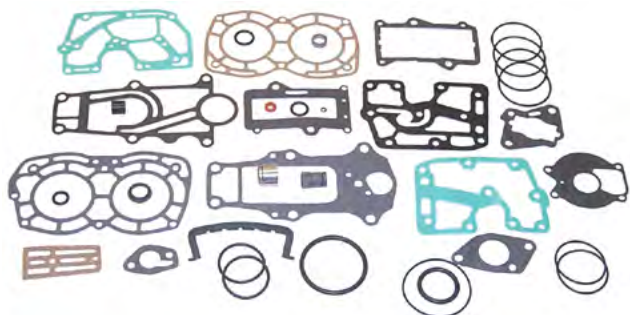

18-4334
JUEGO DE JUNTAS BLOQUE
Reemplaza: 27-41499A87
Desde: 15HP, 18HP, 20HP & 25HP fuerabordas

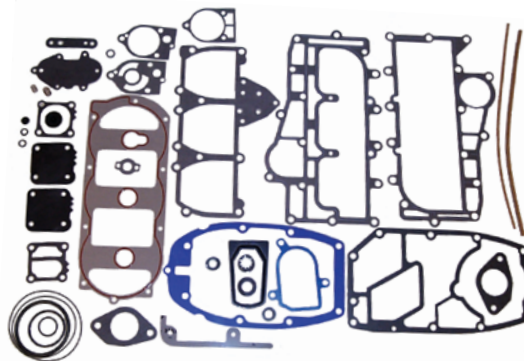

18-4326
JUEGO DE JUNTAS BLOQUE
Reemplaza: 27-43779A87
Desde: 50,55,60 HP, 3 cil.

— CONTIENE —

Ref #	Descripción	O.E.#	Cant.
18-4261	Arandela	19643	1
18-0320	Junta	27-13937-6	6
18-0324	Junta	27-15172-3	3
18-0670	Junta	27-43007 5	1
18-2565	Junta	27-43047-1	1
18-2945	Arandela	12-20260	3
18-7164	Aro tórico	25-33466	1
18-7198	Aro tórico	25-45710	1
18-7167	Aro tórico	25-45254	1
18-0182	Junta	27-62386	1
18-2740	Junta	27-43005 7	1
18-2741	Junta	27-43004 7	2
18-0339	Junta termostato	27-43006-2	1
18-0341	Junta	27-43008, 27-430082, 27-430083, 27-430085	1
18-2563	Junta	27-43034-1	1
18-2564	Junta	22-43033-1	1
18-2566	Junta impulsor	27-817277	1
18-7105	Aro tórico	25-62705	2
18-7414	Aro tórico	25-64067	1
18-0858	Aro tórico	25-54029	1
18-7803	Kit diafragma	21-857005A1	1

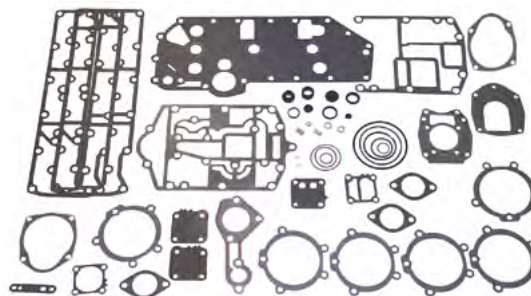

18-4336
JUEGO DE JUNTAS BLOQUE
Reemplaza: 27-43004A99, 27-43004A90, 27-43004A86
Desde: 70, 80, 90HP 3 cil fuerabordas

LAS APLICACIONES DE JUEGOS DE JUNTAS EMPIEZAN EN LA PÁGINA 86
***JUEGO DE JUNTAS BLOQUE NO INCLUYE JUNTA CULATA**

Introducing

SONAR **PRO**

SIERRA ONLINE APPLICATION RESOURCE



Login to: <http://sonar.seastarsolutions.com>

SONAR PRO FEATURES INCLUDE

- Parts Interchange
- Parts Category Search
- Model Search
- New Products
- Diagrams & Exploded Views
- Search Parts By Keyword
- Send Us Your Feedback
- Warranty Tracker
- Free

www.seastarsolutions.com

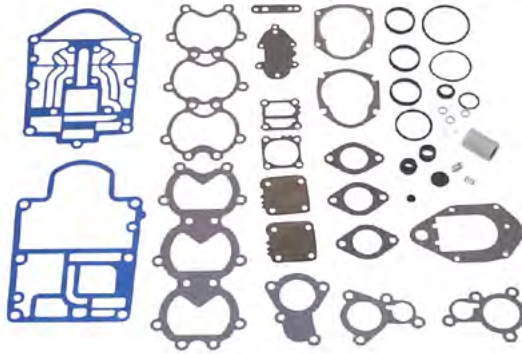

**18-4337
JUEGO DE JUNTAS BLOQUE**

Reemplaza: 27-812867A97, 27-812867A96, 27-812867A91
Desde: 45 Jet, 50HP, 55HP, 60HP, 3 cil Fueraborda

CONTIENE --

Ref #	Descripción	O.E.#	Cant.
18-7152	Aro tórico	25-20863	1
18-2244	Arandela	10-79953A2	3
18-7173	Aro tórico	25-30224	1
18-0182	Junta termostato	27-62386	1
18-2719	Junta colector	27-812869	1
18-2721	Junta adaptador platina	27-827284	1
18-2729	Junta tapa termostato	27-812867 2	1
18-2749	Junta	27-812867 1	1
NSS	Junta escape	27-812866	1
18-0319	Junta tapa escape	27-828533	1
18-0622	Junta platina	27-19701	1
18-0345	Junta bomba de agua	27-722189	1
18-2593	Junta bomba de agua	N/A	1
18-2566	Junta impulsor	27-817277	1
18-7176	Aro tórico	25-90011	1
18-7950	Aro tórico	25-45258	1
18-7817	Kit diafragma	21-857005A1	1

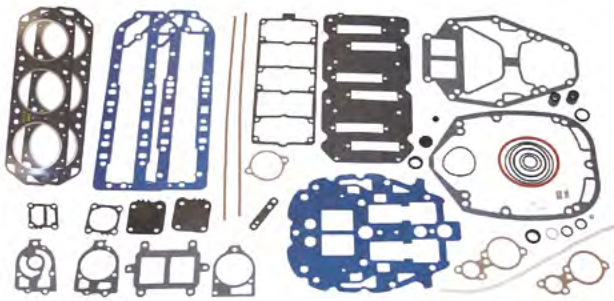

**18-4339
JUEGO DE JUNTAS BLOQUE**

Reemplaza: 27-14697A87
Para: V200EFI y V220 fueraborda

CONTIENE --

Ref #	Descripción	O.E.#	Cant.
18-3862	Junta culata	27-41246-1	2
18-7153	Aro tórico	25-21836	1
18-7164	Aro tórico	25-33466	1
18-7159	Aro tórico	25-31534	1
18-0135	Junta	27-78246	1
18-7426	Aro	25-30271	1
18-0182	Junta	27-62386	2
18-0860	Aro tórico	25-62700	1
18-0936	Junta	27-78690	2
18-2919	Junta	27-42631-1	1
18-2915	Junta	27-85609-1	1
18-2506-1	Junta platina escape	27-99176-3	1
18-2503	Junta platina	27-99177-1	1
18-2513	Junta	27-11338	2
18-0644	Junta	27-14697-2	1
18-0645	Junta	27-16737-1	1
18-2502	Junta	27-90484-1	2
18-2511	Junta	27-99173-2	1
18-2914	Junta	27-85608-1	1
18-3110	Casquillo	26-38970	2
18-7174	Aro tórico	25-45711	2
18-7176	Aro tórico	25-90011	1
18-8305	Retén	26-814754	1
18-0858	Aro tórico	25-54029	1
18-0952	Junta	27-88907	1
18-7421	Aro tórico	25-20415	1
18-0970	Junta bomba combustible	27-98769-1	1
18-7817	Kit diafragma	21-857005A1	1

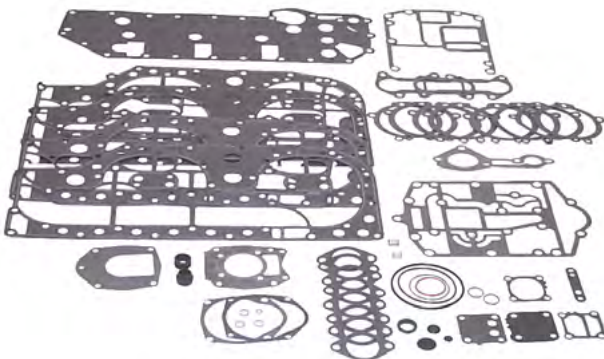

**18-4340
JUEGO DE JUNTAS DE BLOQUE**

Reemplaza: 27-13461A99, 27-13461A90, 27-13461A89, 27-13461A88
Para: 80 Jet, 100HP, 115HP, and 125HP 4 cil Fueraborda

CONTIENE --

Ref #	Descripción	O.E.#	Cant.
18-4261	Arandela	19643	1
18-7961	Aro tórico	25-47254	1
18-0320	Junta	27-13937-6	8
18-0324	Junta	27-15172 4	8
18-0670	Junta	27-43007-5	1
18-2565	Junta	27-43047-2	1
18-2945	Arandela	12-19183	3
18-7198	Aro tórico	25-45710	1
18-0182	Junta	27-62386	1
NSS	Junta	27-13461-2	2
18-2943	Junta	27-44328-4	1
18-2621	Junta platina	27-13958-1	2
18-2610	Junta	27-812775-4	1
18-2611	Junta platina	27-812775-5	1
18-0339	Junta termostato	27-43006-2	1
18-0341	Junta	27-43008-6, 27-43008, 27-430082, 27-430083, 27-430085	1
18-2563	Junta	27-43034-1	1
18-2564	Junta	27-43033-1	1
18-2566	Junta impulsor	27-817277	1
18-7105	Aro tórico	25-62705	1
18-7414	Aro tórico	25-64067	1
18-0858	Aro tórico	25-54029	1
18-0970	Junta bomba combustible	27-98769-1	1
18-7817	Kit diafragma	21-857005A1	1

LAS APLICACIONES DE JUEGOS DE JUNTAS EMPIEZAN EN LA PÁGINA 86
***JUEGO DE JUNTAS BLOQUE NO INCLUYE JUNTA CULATA**

-- CONTIENE --

Ref #	Descripción	O.E.#	Cant.
18-0182	Junta termostato	27-62386	2
18-0858	Aro tórico	254029	1
18-0860	Aro tórico	25-62700	1
18-0129	Junta	27-65744-3	6
18-0135	Junta	27-78246	1
18-0936	Junta platina	27-78690	2
18-0952	Junta platina	27-88907	2
18-7421	Aro tórico	25-20415	2
18-7411	Aro tórico	25-35480	1
18-2501	Junta alojamiento	27-93536-1	1
18-2502	Junta	27-90484-1	2
18-2503	Junta platina	27-99177-1	1
18-2506	Junta platina	27-99176-3	1
18-2508	Junta platina	27-99776-1	2
18-2509	Junta montaje carburador	27-67751	3
18-2510	Junta alojamiento	27-96761-1	1
18-2511	Junta platina	27-99173-2	1
18-2513	Junta cilindro	27-11338	2
18-2803	Junta montaje carburador	27-90430	3
18-2808	Tapa cilindro	27-96278	2
18-2826	Junta alojamiento	27-85610-1	1
18-2914	Junta bomba de agua	27-85608-1	1
18-2915	Junta bomba de agua	27-85609-1	1
18-3110	Casquillo	26-38970	2
18-7153	Aro tórico	25-25439	1
18-7157	Aro tórico	25-29976	1
18-7159	Aro tórico	25-31534	1
18-7162	Aro tórico	25-33145	1
18-7164	Aro tórico	25-33466	1
18-7168	Aro tórico	25-48171	4
18-7174	Aro tórico	25-45711	2
18-7176	Aro tórico	25-90011	1
18-7812	Kit bomba combustible	89031A2	1
18-3863	Junta culata	27-96542-1	2
18-0359	Junta tapa	27-67275-1	1
18-0384	Junta carburador	27-89221-1	3
18-2919	Junta bomba de agua	27-42631-1	1
18-7406	Aro tórico	—	1

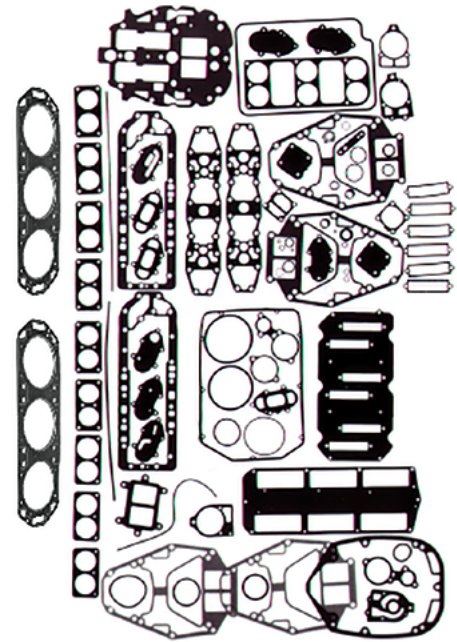

18-4317
JUEGO DE JUNTAS BLOQUE
 Reemplaza: 27-90484A88, 27-90484A86, 27-90484A32

-- CONTIENE --

Ref #	Descripción	O.E.#	Cant.
18-0182	Junta termostato	27-62386	2
18-0858	Aro tórico	254029	1
18-0860	Aro tórico	25-62700	1
18-0129	Junta	27-65744-3	6
18-0135	Junta	27-78246	1
18-0936	Junta platina	27-78690	2
18-0952	Junta platina	27-88907	2
18-7421	Aro tórico	25-20415	2
18-7411	Aro tórico	25-35480	1
18-2501	Junta alojamiento	27-93536-1	1
18-2502	Junta	27-90484-1	2
18-2503	Junta platina	27-99177-1	1
18-2506	Junta platina escape	27-99176-3	1
18-2508	Junta platina escape	27-99776-1	2
18-2509	Junta montaje carburador	27-67751	3
18-2510	Junta alojamiento	27-96761-1	1
18-2511	Junta platina	27-99173-2	1
18-2513	Junta cilindro	27-11338	2
18-2803	Junta montaje carburador	27-90430	3
18-2808	Tapa cilindro	27-96278	2
18-2826	Junta alojamiento	27-85610-1	1
18-2914	Junta bomba de agua	27-85608-1	1
18-2915	Junta bomba de agua	27-85609-1	1
18-3110	Casquillo	26-38970	2
18-7153	Aro tórico	25-25439	1
18-7157	Aro tórico	25-29976	1
18-7159	Aro tórico	25-31534	1
18-7162	Aro tórico	25-33145	1
18-7164	Aro tórico	25-33466	1
18-7168	Aro tórico	25-48171	4
18-7174	Aro tórico	25-45711	2
18-7176	Aro tórico	25-90011	1
18-7812	Kit bomba combustible	89031A2	1
18-3862	Junta culata	27-41246-1	2
18-0359	Junta tapa	27-67275-1	1
18-0384	Junta carburador	27-89221-1	3
18-2919	Junta bomba de agua	27-42631-1	1
18-7406	Aro tórico	—	1
18-7176	Aro tórico	25-90011	1

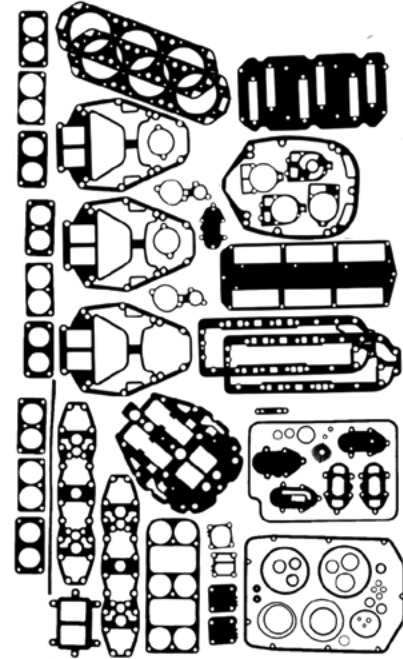

18-4319
JUEGO DE JUNTAS BLOQUE
 Reemplaza: 27-11338A88, 27-89221A88, 27-89221A85, 27-89221A84, 27-89221A32, 27-11338A85

-- CONTIENE --

Ref #	Descripción	O.E.#	Cant.
18-0940	Junta escape	27-85488-2	1
18-0879	Junta platina	27-38501-1	1
18-2810	Junta tapa	27-43777-2	1
18-0103	Junta platina	27-79650-1	2
18-0137	Junta platina	27-85492-2	1
18-2800	Junta carburador	27-75791-1	2
18-0870	Junta tapa	27-27936-1	2
18-0539	Junta	37721	1
18-7161	Aro tórico	25-32546	1
18-2844	Junta termostato	27-48818-1	1
18-2823	Junta platina	27-19553	1
18-0938	Junta tubo de agua	27-79797-1	1
18-2825	Junta base bomba de agua	27-32771	1
18-7153	Aro tórico	25-25439	1
18-7151	Aro tórico	25-20081	1



***18-4325**
JUEGO DE JUNTAS BLOQUE
 Reemplaza: 27-85491A90, 25-85491A87

LAS APLICACIONES DE JUEGOS DE JUNTAS EMPIEZAN EN LA PÁGINA 86
***JUEGO DE JUNTAS BLOQUE NO INCLUYE JUNTA CULATA**

— CONTIENE —

Ref #	Descripción	O.E.#	Cant.
18-0912	Junta Platina	27-66102-1	1
18-0133	Junta tapa	27-73665	1
18-0944	Junta tapa	27-85496-1	1
18-0107	Junta tapa escape	27-85498-1	1
18-7421	Aro tórico	25-20415	1
18-3110	Casquillo	26-38970	2
18-7411	Aro tórico	25-35480	1
18-2500	Junta tapa escape	27-85493	1
18-2514	Junta bloque	27-53650	2
18-2802	Junta carburador	27-48164-1	2
18-2826	Junta alojamiento	27-85610	1
18-2835	Junta culata	27-69238	1
18-2914	Junta bomba de agua	27-85608	1
18-2915	Junta bomba de agua	27-85609-1	1
18-7153	Aro tórico	25-25439	1
18-7157	Aro tórico	25-29976	1
18-7161	Aro tórico	25-32546	1
18-7162	Aro tórico	25-33145	1
18-7167	Aro tórico	25-47254	2
18-7807	Kit bomba de combustible	55278A1	1
18-0351	Junta tapa	27-55896	1
18-7426	Aro tórico	25-30271	1
18-4261	Arandela	19643	1

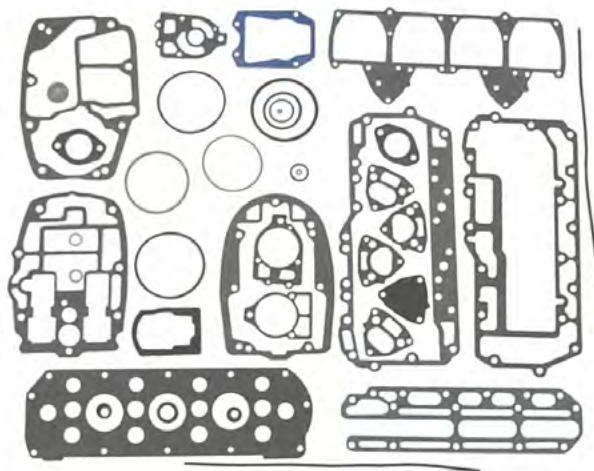

***18-4351**
JUEGO DE JUNTAS BLOQUE
Reemplaza: 27-64203A75, 27-64203A74, 27-64203A73

— CONTIENE —

Ref #	Descripción	O.E.#	Cant.
18-0870	Junta tapa	27-27936-1	2
18-0879	Junta	27-30501-1	1
18-0103	Junta platina	27-79650-1	2
18-0938	Junta tubo de agua	27-79797-1	1
18-0942	Junta platina	27-85491-2	1
18-0137	Junta platina	27-85492-2	1
18-7421	Aro tórico	25-20415	1
18-2507	Junta tapa	27-85487	1
18-2800	Junta carburador	27-75791-1	2
18-2810	Junta tapa	27-43777-2	1
18-2823	Junta platina	27-32769, 27-19553	1
18-2824	Junta cuerpo	27-32770, 27-19551	1
18-2825	Junta base bomba de agua	27-32771	1
18-2841	Junta base bomba de agua	27-77417, 27-19552	1
18-7151	Aro tórico	25-20081	2
18-7153	Aro tórico	25-25439	1
18-7115	Aro tórico	25-26722	1
18-7155	Aro tórico	25-26855	1
18-7160	Aro tórico	25-31986	1
NSS	Aro tórico	25-29619	1
18-7413	Aro tórico	25-62702	2
18-7804	Kit bomba combustible	23014A1	1
18-2571	Junta carburador	27-31402	2



***18-4353**
JUEGO DE JUNTAS BLOQUE
Reemplaza: 27-72486A32, 27-72486A79, 27-72486A78, 27-72486A76, 27-46110A72, 27-46110A2, 27-46110A1

— CONTIENE —

Ref #	Descripción	O.E.#	Cant.
18-0912	Junta platina	27-66102-1	1
18-0926	Junta tapa	27-73645	1
18-0133	Junta tapa	27-73665	1
18-0101	Junta platina carburador	27-76952	2
18-0944	Junta tapa	27-85496-1	1
18-0107	Junta tapa escape	27-85498-1	1
18-7421	Aro tórico	25-20415	1
18-3110	Casquillo	26-38970	1
18-7411	Aro tórico	25-35480	2
18-2500	Junta tapa escape	27-85493	1
18-2505	Junta tapa	27-96171-1	1
18-2514	Junta bloque	27-53650	2
18-2804	Junta carburador	27-73377-1	2
18-2826	Junta base bomba de agua	27-85610-1	1
18-2835	Junta culata	27-69238-1	1
18-2914	Junta bomba de agua	27-85608-1	1
18-2915	Junta bomba de agua	27-85609-1	1
18-7153	Aro tórico	25-25439	1
18-7157	Aro tórico	25-29976	1
18-7161	Aro tórico	25-32546	2
18-7162	Aro tórico	25-33145	1
18-7164	Aro tórico	25-33466	1
18-7167	Aro tórico	25-47254	2
18-7413	Aro tórico	25-62702	2
18-7808	Kit bomba combustible	55278A5	1
18-7426	Aro tórico	25-30271	1
18-4261	Arandela	19643	1

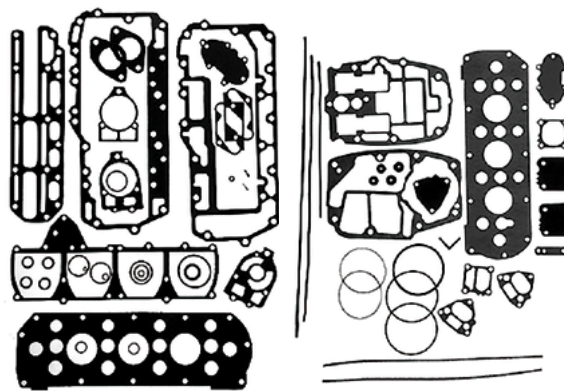

***18-4354**
JUEGO DE JUNTAS BLOQUE
Reemplaza: 27-73645A87, 27-73645A76, 27-73645A32

LAS APLICACIONES DE JUEGOS DE JUNTAS EMPIEZAN EN LA PÁGINA 86
*JUEGO DE JUNTAS BLOQUE NO INCLUYE JUNTA CULATA



***18-4355**
JUEGO DE JUNTAS BLOQUE
 Reemplaza: 27-78028A78, 27-55306A75, 27-55306A74, 27-55306A73, 27-55306A72

-- CONTIENE --

Ref #	Descripción	O.E.#	Cant.
18-0182	Junta termostato	27-62386	1
18-0879	Junta platina	27-38501-1	1
18-0988	Junta platina	27-62860-1	1
18-0914	Junta tapa termostato	27-66847	1
18-0938	Junta tubo de agua	27-79797-1	1
18-0940	Junta platina	27-85488-2	1
18-0105	Junta platina	27-85489-2	1
18-7421	Aro tórico	25-20415	1
18-7411	Aro tórico	25-35480	1
18-2802	Junta carburador	27-48164-1	1
18-2805	Junta tapa	27-85490-2	1
18-2823	Junta platina	27-19553	1
18-2824	Junta cuerpo bomba	27-19551	1
18-2825	Junta base bomba de agua	27-32771	1
18-2838	Junta tapa	27-55279-1	1
18-2841	Junta base bomba de agua	27-19552	1
18-7115	Aro tórico	25-26722	1
18-7143	Aro tórico	25-65936	2
18-7145	Aro tórico	25-64068	3
18-7153	Aro tórico	25-25439	1
18-7155	Aro tórico	25-26855	1
18-7160	Aro tórico	25-31986	1
18-7167	Aro tórico	25-47254	1
18-7413	Aro tórico	25-62702	3
18-7414	Aro tórico	25-64067	1
18-7807	Kit bomba combustible	55278A1	1
18-4261	Arandela	19643	1

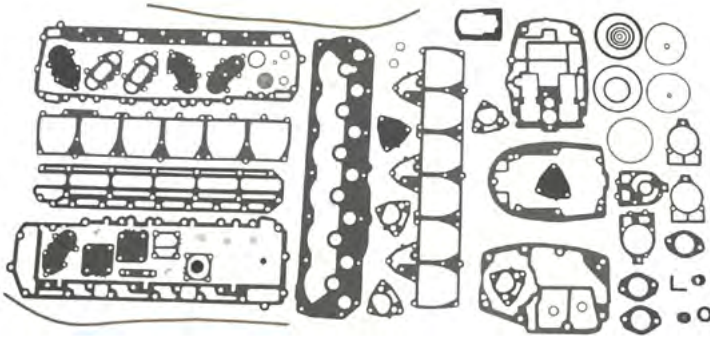

***18-4356**
JUEGO DE JUNTAS BLOQUE
 Reemplaza: 27-85653A87, 27-85653A79, 27-85653A32, 27-60476A75, 27-60476A74, 27-60476A73, 27-60476A72

-- CONTIENE --

Ref #	Descripción	O.E.#	Cant.
18-7153	Aro tórico	25-25439	1
18-7120	Aro tórico	25-38933	1
18-3110	Casquillo	26-38970	2
18-7164	Aro tórico	25-33466	1
18-7167	Aro tórico	25-47254	1
18-2802	Junta carburador	27-48164-1	3
18-7413	Aro tórico	25-62702	2
18-7161	Aro tórico	25-32546	2
18-7173	Aro tórico	25-30224	1
18-3110	Casquillo	26-38970	1
18-7421	Aro tórico	25-20415	1
18-7162	Aro tórico	25-33145	1
18-7157	Aro tórico	25-29976	1
18-2914	Junta bomba de agua	27-85608-1	1
18-2915	Junta bomba de agua	27-85609-1	1
18-2801	Junta bomba de agua	27-32438	1
18-2826	Junta alojamiento	27-85610-1	1
18-0912	Junta alojamiento	27-66102-1	1
18-2573	Junta tapa	27-72142-1	1
18-2574	Junta tapa escape	27-85495-2	1
18-0946	Junta	27-85653-1	1
18-2513	Junta carter a bloque	27-53862	2
18-2807	Junta tapa	27-98185	1
18-2835	Junta culata	27-69238-1	1
18-2839	Tapa escape	27-85497-2	1
18-7807	Kit bomba combustible	55278A1	2
18-7813	Kit bomba combustible	89031A3	1
18-7426	Aro tórico	25-30271	1

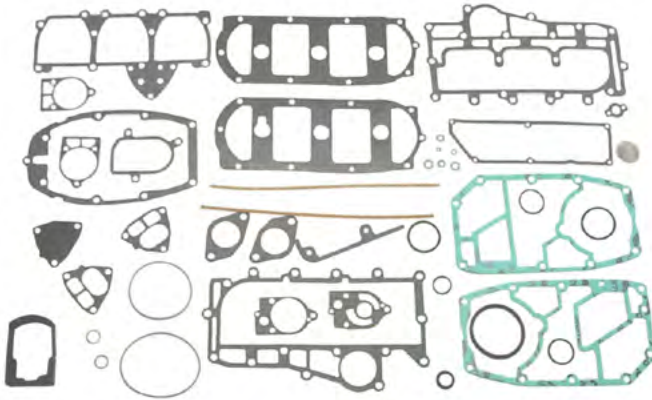

***18-4357**
JUEGO DE JUNTAS BLOQUE
 Reemplaza: 27-88449A32, 27-88449A80, 27-76589A79, 27-76589A78, 27-76589A77, 27-73440A76

-- CONTIENE --

Ref #	Descripción	O.E.#	Cant.
18-0182	Junta termostato	27-62386	1
18-0879	Junta platina	27-38501-1	1
18-0904	Junta	27-60317	1
18-0918	Junta platina	27-69524-2	1
18-0131	Junta platina	27-69525-2	1
18-0922	Junta platina	27-70335-1	1
18-0932	Junta tapa	27-76862-1	1
18-0938	Junta tubo de agua	27-79797-1	1
18-0139	Junta platina	27-88451-1	1
18-7421	Aro tórico	25-20415	1
18-2945	Tapón drenaje	12-20260	2
18-7411	Aro tórico	25-35480	1
18-2504	Junta tapa	27-88449	1
18-2512	Junta cigüeñal	27-60286	2
18-2804	Junta carburador	27-73377-1	2
18-2809	Junta tapa	27-43779-2	1
18-2823	Junta platina	27-19553	1
18-2824	Junta cuerpo bomba	27-19551	1
18-2825	Junta base bomba de agua	27-32771	1
18-2841	Junta base bomba de agua	27-19552	1
18-7143	Aro tórico	27-77417	1
18-7153	Aro tórico	25-25439	1
18-7115	Aro tórico	25-26722	1
18-7155	Aro tórico	25-26855	1
18-7160	Aro tórico	25-31986	1
18-7161	Aro tórico	25-32546	1
18-7413	Aro tórico	25-62702	2
18-7415	Aro tórico	25-64966	1
18-7809	Kit bomba combustible	55278A4	1
18-4261	Arandela	19643	1

-- CONTIENE --

Ref #	Descripción	O.E.#	Cant.
18-0135	Junta adaptador	27-78246	1
18-0182	Junta termostato	27-62386	2
18-0384	Junta carburador	27-89221-1	3
18-0641	Junta carburador	27-828292	3
18-0642	Junta platina	27-19050-3	1
18-0643	Junta platina	27-18307-1	1
18-0644	Junta platina	27-14697-2	1
18-0645	Junta adaptador	27-16737-1	1
18-0646	Junta platina	27-813859	1
18-0838	Aro tórico	—	1
18-0858	Aro tórico	25-54029	1
18-0860	Aro tórico	25-62700	1
18-0936	Junta válvula	27-78690	2
18-2506	Junta	27-99176-3	1
18-2509	Junta carburador	27-67751	3
18-2511	Junta platina	27-99173-2	1
18-2513	Junta cigüeñal	27-11338	2
18-2914	Junta bomba de agua	27-85608-1	1
18-2915	Junta bomba de agua	27-85609-1	1
18-2919	Junta bomba de agua	27-42631-1	1
18-3110	Retén	26-38970	2
18-7153	Aro tórico	25-25439	1
18-7157	Aro tórico	25-29976	1
18-7159	Aro tórico	25-31534	1
18-7174	Aro tórico	25-45711	1
18-7176	Aro tórico	25-90011	1
18-8305	Retén	26-814754	1

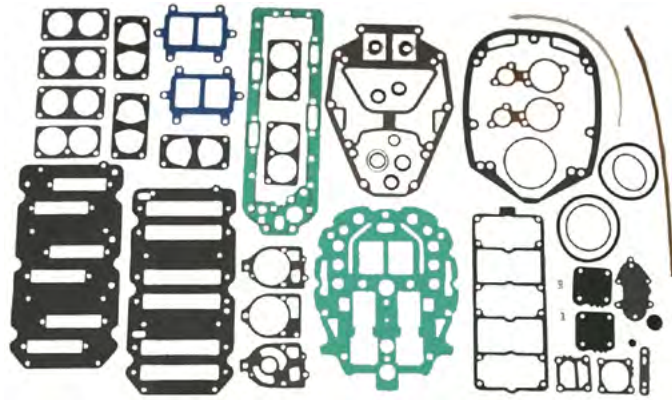

***18-4359**
JUEGO DE JUNTAS BLOQUE
 Reemplaza: 27-815791A92, 27-815792A90, 27-815810A90, 27-815809A90

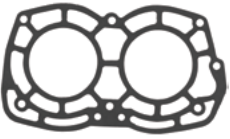

18-2736
JUNTA CULATA
 Reemplaza: 27-863895,
 27-863891, 27-863893
 Para: 15-25HP 2 cil



18-3804
JUNTA CULATA
 Reemplaza: 27-19138M,
 19138, 27-84733M
 Para: Modelo 30A; S/N Cod. 689

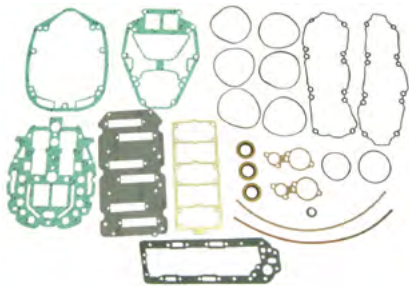

18-64217
JUEGO DE JUNTAS BLOQUE
 Reemplaza: 27-815791A00
 Para: Mercury 150/175 EFI(G960500-T408999)



18-3828
JUNTA CULATA
 Reemplaza: 27-18937M,
 27-18937, 27-98990M,
 27-83899M
 Para: Modelo 9.9C; S/N Code 682 &
 Modelo 15C, S/N Cod. 684



18-3861
JUNTA CULATA
 Reemplaza: 27-187851,
 27-187853, 27-18785T,
 27-187861, 27-187863,
 27-18786T
 Para: Modelo 135, 150 y XR4



18-3862
JUNTA CULATA
 Reemplaza: 27-41246-1
 Para: Modelo 175, 200, XR4



18-3844
JUNTA CULATA
 Reemplaza: 27-803508
 Para: 4-tiempos O/B's, 4/5/6 HP
 S/N OR000001 & Sup



18-3871
JUNTA CULATA
 Reemplaza: 27-18786-1
 Para: Modelo 175, XR4, Mag II



18-3863
JUNTA CULATA
 Reemplaza: 27-96542-1
 Para: Modelo 150



18-3864
JUNTA CULATA
 Reemplaza: 27-822844-1
 Para: Modelo 175, 200 y XR6



18-3872
JUNTA CULATA
 Reemplaza: 27-41245-1
 Para: 200 y 225 HP



18-3845
JUNTA CULATA
 Reemplaza: 27-825032
 Para: 4-tiempos O/B's, 40/45/50 HP
 S/N OG760300 & Sup



18-3827
JUNTA CULATA
 Reemplaza: 27-8254821, 27-825482
 Para: 8, 9.9 HP 4-tiempos



18-60916
JUNTA CULATA
 Reemplaza: 27-850836001
 Para: Mercury 8/9.9 (R042475 & Sup)



PACK DE 5
18-7400
18-7400-9^①
ARO TÓRICO JUNTA CULATA
 Reemplaza: 25-818573
 1 por cilindro, 3 por cabeza de cilindro

① Precio por envase

LAS APLICACIONES EMPIEZAN EN LA SIGUIENTE PÁGINA
***JUEGO DE JUNTAS BLOQUE NO INCLUYE JUNTA CULATA**

JUNTA CULATA/APLICACIONES JUEGO DE JUNTAS













Modelo	Cil.	Desde N° de serie	Hasta N° de serie	Juego de juntas	Aro tórico	Junta culata	Sellos de cabeza
4/5/6 (4 tiempos)	1 CIL	R000001	& Sup	—	—	18-3844	—
8 4 tiempos (232cc)		H000058	H017349	—	—	18-3827	—
8 4 tiempos (232cc)		G760300	T178499	—	—	18-3827	—
9.9 tiempos (232cc)		H000058	H017349	—	—	18-3827	—
18 (18XD)	2	6416713	6443972	18-4334	—	—	—
20 (20,20XD, 200)	2	6443973	OT800999	18-4334	—	—	—
20 JET	2	G044027	& Sup	18-4334	—	—	—
30 JET (40 HP)	4 CIL	C159200	& Sup	18-4325	—	—	—
35	2 CIL	6445653	B110788	18-4355	—	—	—
40,402	2 CIL	3336258	G053313	18-4355	—	—	—
40	4 CIL	C159200	& Sup	18-4325	—	—	—
40 4 tiempos (232cc)	3 CIL	G231123	T178499	—	—	18-3845	—
45	4 CIL	5531630	0B110788	18-4353	—	—	—
45	4 CIL	B110789	& Sup	18-4325	—	—	—
45 Jet	3 CIL	D000750	& Sup	18-4337	—	—	—
45 4 tiempos (BODENSEE)		G231123	T178499	—	—	18-3845	—
50,500	4 CIL	2116318	& Sup	18-4353	—	—	—
50, 60	4 CIL	6428681	B122929	18-4357	—	—	—
50	3 CIL	D000750	OG589999	18-4337	—	—	—
50	3 CIL	B122930	D000749	18-4326	—	—	—
50 4 tiempos		G231123	T178499	—	—	18-3845	—
55	3 CIL	6428681	B122929	18-4357	—	—	—
55	3 CIL	D000750	& Sup	18-4337	—	—	—
65 (650)	3 CIL	3293184	4382056	—	—	—	—
65 (650)	3 CIL	4382057	4571651	18-4357	—	—	—
70	3 CIL	4571652	A996141	18-4357	—	—	—
70	3 CIL	A996142	& Sup	18-4336	—	—	—
75	4 CIL	6432901	& Sup	18-4354	—	—	—
80	3 CIL	A996142	& Sup	18-4336	—	—	—
80 Jet	4 CIL	D283222	& Sup	18-4340	—	—	—
80,800	4 CIL	2559001	3493912	18-4350	—	—	—
80,800	4 CIL	4831999	6432900	18-4354	—	—	—
85,850	4 CIL	3493913	4366801	18-4351	—	—	—
85,850	4 CIL	4366802	4831998	18-4354	—	—	—
90,900	6 CIL	4845301	& Sup	18-4356	—	—	—
90	3 CIL	A996142	& Sup	18-4336	—	—	—
100	4 CIL	B209468	& Sup	18-4340	—	—	—
105 JET	6 CIL	D082000	& Sup	18-4359	—	18-3864②	— 1
115	4 CIL	C100000	& Sup	18-4340	—	—	—
125	4 CIL	D283222	& Sup	18-4340	—	—	—
140 (140, 1400)	6 CIL	3293234	3502805	18-4356	—	—	—
140 (140, 1450)	6 CIL	4865678	& Sup	18-4356	—	—	—
140 (140, 1400)	6 CIL	4865678	& Sup	18-4356	—	—	—
150 (1500)	6 CIL	3502806	5327622	18-4356	—	—	—
V-135	V-6	A904646	C239552	18-4317	—	18-3863	—
V-135	V-6	C239553	G960499	18-4359	—	18-3861	— 1
V-135 DFI	V-6	G590000	G960499	18-4338	—	—	— 1
140 JET	V-6	D082000	G960499	18-4359	—	18-3864	— 1
V-150 (150, 1500)	V-6	4868998	6042945	18-4315	—	—	—
V-150	V-6	6042946	C239552	18-4317	—	18-3863	—
V-150	V-6	C239553	G960499	18-4359	—	18-3861	— 1
V-150	V-6	G960500	& Sup	18-4338	—	—	— 6
V-150 (XR/MAGNUM II)	V-6	B242885	C239552	18-4319	—	—	—
V-150 XR4	V-6	C239553	D081999	18-4359	—	18-3871	— 1
V-150 (XR6/MAGNUM III)	V-6	D082000	G960499	18-4359	—	18-3864②④	— 1
V-150 (EFI)		D082000	G960499	18-4359	N/D	—	— 1
150 MAR	V-6	5600162	6038680	18-4315	—	—	—

① Juego de juntas incluye junta culata ④ Usado en un 2.5L con 3.5" 1 Junta culata no incluida en kit 6 Aros y retenes no incluidos en el kit
 ② Necesita 2 juntas culata ⑤ necesita 3 por cabeza de cilindro 2 Aros y retenes no incluidos en el kit
 ③ Usado en un 2.4L con 3.38" 3 Aros y retenes no incluidos en el kit







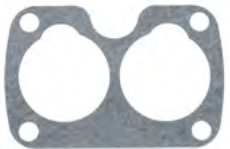















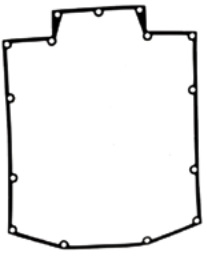

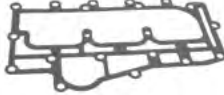

JUNTA CULATA/APLICACIONES JUEGO DE JUNTAS

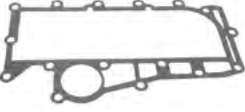
Modelo	Cil.	Desde N° de serie	Hasta N° de serie	Juego de juntas	Aro tórico	Junta culata	Sellos de cabeza
150 MAR	V-6	6038681	C239553	18-4317 ①	—	18-3863②	—
150 MAR	V-6	C239554	& Sup	18-4359	—	18-3861②	—
V-175 (175, 1750)	V-6	4301235	6618750	18-4315	—	—	—
V-175	V-6	6618751	C239552	18-4319 ①	—	18-3862	—
V-175	V-6	C239553	D081999	18-4359	—	18-3871②③	— 1
V-175	V-6	D082000	G960499	18-4359	—	18-3864②④	—
V-175 (EFI)	V-6	D000750	D081999	18-4359	—	18-3871②③	— 1
V-175 XRI EFI	V-6	D000750	D081999	18-4359	—	18-3864②④	—
V-175 (EFI)	V-6	D082000	G303045	18-4359	—	18-3864②④	— 1
V-200 (200,2000)	V-6	4839034	6073191	—	—	18-3872②	—
V-200	V-6	6073192	6203990	—	—	18-3872②	—
V-200	V-6	6203991	C291519	18-4319 ①	—	18-3862②③	—
V-200	V-6	C291520	D081999	18-4359	—	18-3864②④	— 1
V-200	V-6	D082000	G960499	18-4359	—	—	— 1
V-200 (EFI)	V-6	C100861	OC291519	18-4339	—	18-3862	—
V-200 (EFI)	V-6	C291520	G960499	18-4359	—	18-3864	— 1
V-200 (DFI) 3.0L	V-6	G386496	G589999	—	18-7400	—	—
V-200 (DFI) 3.0L	V-6	G590000	G960499	18-4335	18-7400	—	— 2
V-200 (DFI) 3.0L	V-6	G960500	T178499	—	18-7400	—	— 3
V-200 XRI EFI	V-6	C100861	C291519	—	—	18-3862②	—
V-200 XRI EFI	V-6	C291520	& Sup	18-4359	—	18-3864②④	—
V-220	V-6	B117316	& Sup	18-4339	—	18-3862②	—
V-225 SEA PRO	V-6	G245605	OT408999	—	18-7400 ⑤	—	—
V-225 (EFI) 3.0L	V-6	G129222	T408999	—	18-7400 ⑤	—	—
V-225 DFI (3.0L)	V-6	G590000	OG960499	18-4335	18-7400 ⑤	—	— 3
V-225 DFI (3.0L)	V-6	G960500	T178499	—	18-7400 ⑤	—	— 3
V-250 (EFI) 3.0L	V-6	G129222	T408999	—	18-7400 ⑤	—	—

- | | | | |
|--|-------------------------------------|---|---|
| ① Juego de juntas incluye junta culata | ④ Usado en un 2.5L con 3.5" | 1 Junta culata no incluida en kit | 6 Aros y retenes no incluidos en el kit |
| ② Necesita 2 juntas culata | ⑤ Necesita 3 por cabeza de cilindro | 2 Aros y retenes no incluidos en el kit | |
| ③ Usado en un 2.4L con 3.38" | | 3 Aros y retenes no incluidos en el kit | |























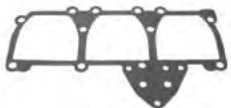

 <p>18-2737 JUNTA BLOQUE Reemplaza: 27-850283. Para 200DFI, 225DFI.</p>	 <p>18-0324 JUNTA CARBURADOR Reemplaza: 27-15172 3, 27-151724, 27-15172, 27-93214</p>	 <p>18-0384 JUNTA CARBURADOR Reemplaza: 27-892211, 27-817533, 27-89221, 27-8M0027781 200/225 HP</p>	 <p>18-0633 JUNTA CARBURADOR Reemplaza: 27-192061, 27-42178, 27-19206, 27-414491, 27-41449</p>	
 <p>18-0641 JUNTA CARBURADOR Reemplaza: 27-828292</p>	<p>Pack. de 3</p>  <p>18-2509 JUNTA CARBURADOR Reemplaza: 27-67751 V-6</p>	<p>Pack. de 2</p>  <p>18-2571 18-2571-9⑥ JUNTA CARBURADOR Reemplaza: 27-31402</p>	<p>Pack. de 2</p>  <p>18-2572 18-2572-9⑥ JUNTA CARBURADOR Reemplaza: 27-63309, 27-22023</p>	
<p>Pack. de 2</p>  <p>18-2800 18-2800-9⑥ JUNTA CARBURADOR Reemplaza: 27-757911, 27-75791, 27-69659, 27-26891 20-45-50 HP</p>	<p>Pack. de 2</p>  <p>18-2802 18-2802-9⑥ JUNTA CARBURADOR Reemplaza: 27-48164, 27-481641</p>	<p>Pack. de 3</p>  <p>18-2803 18-2803-9⑥ JUNTA CARBURADOR Reemplaza: 27-90430, 27-904301 V-6</p>	<p>Pack. de 4</p>  <p>18-2804 18-2804-9⑥ JUNTA CARBURADOR Reemplaza: 27-733771, 27-73377 3-4 Cil.</p>	 <p>18-0740 JUNTA CUERPO ACELERADOR Reemplaza: 27-805396</p>

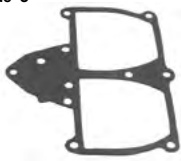
⑥ Precio por envase

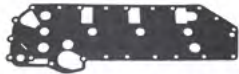
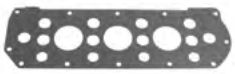
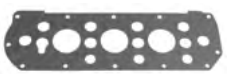

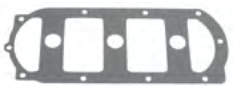







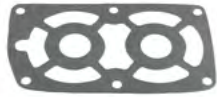





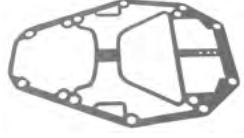

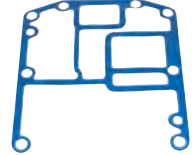

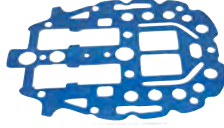





 <p>18-2568 18-2568-9^① JUNTA TAPA Reemplaza: 27-25848</p>	 <p>18-2569 18-2569-9^① JUNTA TAPA FILTRO Reemplaza: 27-25849</p>	 <p>18-2570 18-2570-9^① JUNTA TAPA Reemplaza: 27-25851, 27-34614</p>	 <p>18-2575 18-2575-9^① JUNTA CARBURADOR Reemplaza: 1399-99</p>	 <p>18-0970 18-0970-9^① BASE BOMBA COM- BUSTIBLE Reemplaza: 27-987691, 27-98769</p>												
 <p>18-0359 JUNTA TAPA SILENCIADOR Reemplaza: 27-672751, 27-67275</p>	 <p>18-0129 JUNTA Reemplaza: 27-657443, 27-657442, 27-657441, 27-65744 V-6</p>	 <p>18-0320 JUNTA Reemplaza: 27-13937-6</p>	 <p>18-0644 JUNTA PLATINA Reemplaza: 27-146972</p>													
 <p>18-0646 JUNTA PLATINA Reemplaza: 27-813859</p>	 <p>18-2501 18-2501-9^① JUNTA ALOJAMIENTO Reemplaza: 27-935361, 27- 93536, 27-67738 V-6</p>	 <p>18-2510 18-2510-9^① JUNTA ALOJAMIENTO Reemplaza: 27-967611, 27-96761 V-200</p>	<p>Pack. de 5</p> <p>JUNTAS CARCASA CIGÜEÑAL</p> <table border="1"> <thead> <tr> <th>Ref #</th> <th>Reemplaza:</th> <th>Descripción</th> </tr> </thead> <tbody> <tr> <td>18-2512 ^②</td> <td>27-60286</td> <td>Junta carter 3 cilindros</td> </tr> <tr> <td>18-2513 ^②</td> <td>27-11338, 27-67208</td> <td>Junta carter V-6</td> </tr> <tr> <td>18-2514 ^②</td> <td>27-53650</td> <td>Junta carter 4 cilindros</td> </tr> </tbody> </table>		Ref #	Reemplaza:	Descripción	18-2512 ^②	27-60286	Junta carter 3 cilindros	18-2513 ^②	27-11338, 27-67208	Junta carter V-6	18-2514 ^②	27-53650	Junta carter 4 cilindros
Ref #	Reemplaza:	Descripción														
18-2512 ^②	27-60286	Junta carter 3 cilindros														
18-2513 ^②	27-11338, 27-67208	Junta carter V-6														
18-2514 ^②	27-53650	Junta carter 4 cilindros														
 <p>18-0624 JUNTA ATENUADOR Reemplaza: 27-188891</p>	 <p>18-0645 JUNTA PLATINO Reemplaza: 27-167371</p>	 <p>18-0107 JUNTA TAPA ESCAPE Reemplaza: 27-85498-1, 27-85498, 27-64203, 27-72510 4 Cil.</p>	 <p>18-0131 JUNTA Reemplaza: 27-695252, 27-695251, 27-69525, 27-64857 3 Cil.</p>	 <p>18-0133 JUNTA TAPA Reemplaza: 27-73665, 27-52892 4 Cil.</p>  <p>18-0137 JUNTA PLATINA Reemplaza: 27-85492-2 50 HP</p>												
 <p>18-0371 JUNTA PLATINA Reemplaza: 27-78409, 27-39316, 27-72915 20 HP</p>	 <p>18-0373 JUNTA PLATINA Reemplaza: 27-78411, 27-45088, 27-72917 20 HP</p>	 <p>18-0918 JUNTA TAPA ESCAPE Reemplaza: 27-695242, 27-695241, 27-69524 3 Cil.</p>	 <p>18-2712 JUNTA PLATINA Reemplaza: 27-414181, 27-41418, 27-85979 Para: 15-25 2 cil</p>	 <p>18-2621 JUNTA PLATINA Reemplaza: 27-139581 Para: 100HP 4 cil, 115HP 4 cil</p>												
 <p>18-0380 JUNTA TERMOSTATO Reemplaza: 27-83940M</p>	 <p>18-2710 JUNTA Reemplaza: 27-414172, 27-414171, 27-41417, 27-85978 Para: 15-25HP 2 cil</p>	 <p>18-2721 JUNTA TERMOSTATO Reemplaza: 27-827284 Para: 30-60HP 3 cil fuerabordas</p>	 <p>18-2729 JUNTA TERMOSTATO Reemplaza: 27-8128672 Para: 30-40HP 2 cil, 45 Jet, 50-60 3 cil</p>	 <p>18-2749 JUNTA TERMOSTATO Reemplaza: 27-8128671, 27-812867 Para: 45 Jet, 50-60 HP 3 cil</p>												



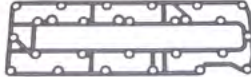

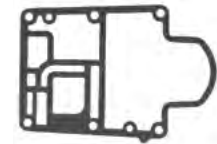





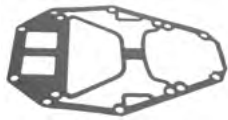

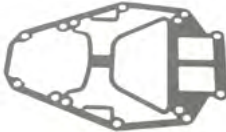

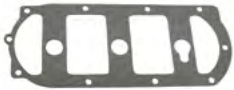
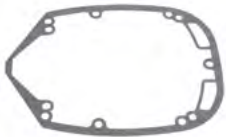







① Precio por envase

② Este producto tiene un precio por pieza . Para pedir el precio por paquete , por favor agregue -9 al número de pieza













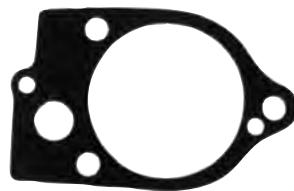

 <p>18-3675 JUNTA TERMOSTATO Reemplaza: 27-850318, 27-8503181 Para: 200-250HP 3.0L, (DFI y EFI)</p>	<p>Pack. de 2</p>  <p>18-0922 18-0922-9① JUNTA PLATINA Reemplaza: 27-703351, 27-70335 3 Cil.</p>	 <p>18-0940 JUNTA PLATINA Reemplaza: 27-854882, 27- 854881, 27-85488, 27-78027, 27-55308</p>	 <p>18-0942 JUNTA PLATINA Reemplaza: 27-85491-2, 27-854913, 27-854911, 27-85491, 27-72486, 27-46110 45/50 HP</p>	 <p>18-0944 JUNTA PLATINA Reemplaza: 27-854961, 27-85496, 27-64204, 27-72508</p>
 <p>18-0232 JUNTA TAPA Reemplaza: 27-81031M</p>	<p>Pack. de 2</p>  <p>18-2573 18-2573-9① JUNTA TAPA Reemplaza: 27-721421, 27-72142, 27-60475 6 Cil.</p>	<p>Pack. de 2</p>  <p>18-2574 18-2574-9① JUNTA TAPA ESCAPE Reemplaza: 27-854952, 27- 854951, 27-85495, 27-72507, 27-60476 6 Cil.</p>	<p>Pack. de 2</p>  <p>18-2836 18-2836-9① JUNTA TAPA ESCAPE Reemplaza: 27-78035, 27-72919, 27-46233, 27-31439 7.5-10 HP</p>	<p>Pack. de 2</p>  <p>18-2839 18-2839-9① JUNTA TAPA ESCAPE Reemplaza: 27-854972, 27-854971, 27-85497, 27-72509, 27-60477</p>
 <p>18-0151 JUNTA TAPA ESCAPE Reemplaza: 27-76636, 27-75952 V-6</p>	 <p>18-0642 JUNTA Reemplaza: 27-190503, 27-19050, 27-190502, 27-190505</p>	<p>Pack. de 2</p>  <p>18-2502 18-2502-9① JUNTA PLATINA Reemplaza: 27-904841, 27-90484, 27-87396 V-6</p>	 <p>18-0870 JUNTA TAPA Reemplaza: 27-279361, 27-27936</p>	 <p>18-0926 JUNTA TAPA Reemplaza: 27-73645</p>
 <p>18-0932 JUNTA TAPA Reemplaza: 27-768621, 27-76862 3 Cil.</p>	 <p>18-0946 JUNTA TAPA Reemplaza: 27-85653-1, 27-856730, 27-85653 6 Cil.</p>	<p>Pack. de 3</p>  <p>18-2838 18-2838-9① JUNTA TAPA Reemplaza: 27-552791, 27-55279</p>	 <p>18-0372 JUNTA TAPA Reemplaza: 27-78410, 27- 52579, 27-72916 20 HP</p>	 <p>18-2740 JUNTA TAPA Reemplaza: 27-430057, 27-430056, 27-430055, 27- 430053, 27-430052, 27-430051 Para: 65 Jet, 75HP 3 cil, 90HP 3 cil</p>
 <p>18-2943 JUNTA TAPA Reemplaza: 27-443281, 27-443282, 27-443283, 27-443284 Para: 81 Jet, 100HP, 115HP, y 125HP 4 cil fuerabordas</p>	<p>Pack de 2</p>  <p>18-2500 18-2500-9① JUNTA TAPA ESCAPE Reemplaza: 27-85493, 27-72505, 27-52893 80 HP</p>	<p>Pack de 2</p>  <p>18-2505 18-2505-9① JUNTA TAPA Reemplaza: 27-961711, 27-96171 75-80 HP</p>	<p>Pack de 2</p>  <p>18-2507 18-2507-9① JUNTA TAPA Reemplaza: 27-85487, 27- 78026, 27-72487, 27-37816 40-50 HP</p>	<p>Pack de 2</p>  <p>18-2805 18-2805-9① JUNTA TAPA Reemplaza: 27-85490-2 35-40 HP</p>
<p>Pack. de 2</p>  <p>18-2504 18-2504-9① JUNTA TAPA BLOQUE Reemplaza: 27-88449, 27-76401, 27-74511, 27-60310 3 Cil.</p>	<p>Pack. de 2</p>  <p>18-2806 18-2806-9① JUNTA TAPA Reemplaza: 27-65788 V-6</p>	<p>Pack. de 2</p>  <p>18-2807 18-2807-9① JUNTA TAPA Reemplaza: 27-981853, 27-9818512, 27-981851, 27-98185, 27-85494, 27-72506, 27-64940, 27-53863 90-115 HP</p>	<p>Pack. de 2</p>  <p>18-2808 18-2808-9① JUNTA TAPA Reemplaza: 27-96278 V-6</p>	 <p>18-60917 JUNTA TAPA CILINDRO Reemplaza: 27-803508017 Para: Mercury 8/9.9 (R042475 & Sup)</p>

① Precio por envase

<p>Pack. de 2</p>  <p>18-2810 18-2810-9① JUNTA TAPA Reemplaza: 27-437772, 27-437771, 27-43777, 27-96483 45-50 HP</p>	<p>Pack. de 2</p>  <p>18-2837 18-2837-9① JUNTA TAPA Reemplaza: 27-41382, 27- 78087, 27-72918, 27-66358, 27-31436</p>	 <p>18-0333 JUNTA BASE Reemplaza: 27-39401</p>	 <p>18-0334 JUNTA BASE Reemplaza: 27-39402</p>	 <p>18-0336 JUNTA BASE Reemplaza: 27-41670-3, 27-41670-5 18 HP</p>
<p>18-0649 JUNTA ALOJAMIENTO CAMBIO Reemplaza: 27-858935 Para: 200 HP T801000 & SUP, 200 HP OPTIMAX DFI G438000 & SUP, 225 HP EFI G438000 & SUP, 225 HP OPTIMAX DFI G590000-G960499, 250 HP EFI G438000 & SUP, (MODELOS CON "C-3": 200 HP OPTI- MAX DFI G386496-G437999, 225 HP D280813-G437999, 225 HP EFI G129222-G437999, 250 HP EFI G129222-G437999)</p>	 <p>18-0341 JUNTA BASE Reemplaza: 27-430086, 27-43008, 27-430082, 27- 430083, 27-430085 Para: 70-90, 100, 115 & 125 HP</p>	 <p>18-0791 JUNTA TAPA CAMBIO Reemplaza: 27-880729 Para: Todos los verado 135/150/175/200 225/250/275</p>	 <p>18-0369 JUNTA BASE Reemplaza: 27-75909 V-6</p>	
 <p>18-0378 JUNTA BASE Reemplaza: 27-823142, 27-823142 2</p>	 <p>18-0670 JUNTA BASE Reemplaza: 27-430075, 27-430073, 27-43007</p>	 <p>18-0385 JUNTA BASE Reemplaza: 27-89937, 27-31557, 27-30803, 27-45748 4.5-9.8 HP</p>	 <p>18-0643 JUNTA BASE Reemplaza: 27-18307-1, 27-183076</p>	 <p>18-0879 JUNTA BASE Reemplaza: 27-385011, 27-38501, 27-37724</p>
 <p>18-0904 JUNTA BASE Reemplaza: 27-60317 65 HP</p>	 <p>18-0135 JUNTA ADAPTADOR Reemplaza: 27-78246, 27-78246 1</p>	 <p>18-0103 JUNTA BASE Reemplaza: 27-796501, 27-79650, 27-37725, 27-72496</p>	 <p>18-0139 JUNTA BASE Reemplaza: 27-884511, 27-88451, 27-78623, 27-76589</p>	 <p>18-2735 JUNTA PLATINA Reemplaza: 27-190506 Para: 140 Jet, 115-200HP (2.5L), XR-6</p>
 <p>18-2713 JUNTA ALOJAMIENTO Reemplaza: 27-433374, 27-43337, 27-43337A1, 27-433371, 27-433372, 27-433373, 27-96286 Para: 15-25 2 cil</p>	 <p>18-2714 JUNTA TAPA ESCAPE Reemplaza: 27-414995, 27-414994, 27-414993, 27-414992, 27-892157 Para: 15-25 HP, 2 Cil.</p>	 <p>18-2716 JUNTA TAPA ESCAPE Reemplaza: 27-414991, 27-41499, 27-92332 Para: 18XD, 20XD (2 cil), 25XD</p>	 <p>18-2741 JUNTA TAPA ESCAPE Reemplaza: 27-430047, 27-430045, 27-430043, 27-430042, 27-430041, 27-43004009 Para: 65 Jet, 75HP 3 cil, 90HP 3 cil</p>	 <p>18-2717 JUNTA COLECTOR ESCAPE Reemplaza: 27-414758, 27-414757, 27-414756, 27-414755, 27-414754, 27-414753, 27-414752, 27- 414751, 27-41475, 27-92331, 27-892158 Para: 15-25HP 2 cil</p>
 <p>18-0319 JUNTA BASE Reemplaza: 27-828553 Para: 30-60HP 2 cil and 3 cil</p>	 <p>18-2610 JUNTA Reemplaza: 27-8127754, 27-812755 Para: 81 Jet, 100HP, 115HP, y 125HP 4 cil fuerabordas</p>	 <p>18-2739 JUNTA PLATINA Reemplaza: 27-8329335, 27-8329334, 27-8329333, 27-8329332, 27-8329331, 27-832933006 Para: 250XS (3.0L) DFI</p>	 <p>18-2611 JUNTA Reemplaza: 27-8127551, 27-8127755, 27-812755A01 Para: 80 Jet, 100HP, 115HP, y 125HP 4 cil fueraborda</p>	 <p>18-0912 JUNTA PLATINA ALOJAMIENTO EJE Reemplaza: 27-661021, 27-66102, 27-60945</p>

 <p>18-0934-1 JUNTA BASE BLOQUE Reemplaza: 27-78069</p>	 <p>18-0988 JUNTA BASE BLOQUE Reemplaza: 27-628601, 27-62860, 27-37976</p>	 <p>Pack. de 2 18-2503 18-2503-9① JUNTA PLATINA ESCAPE Reemplaza: 27-991771, 27-991772, 27-99177, 27- 78068 V-6</p>	 <p>Pack. de 2 18-2506-1 18-2506-1-9① JUNTA PLATINA ESCAPE Reemplaza: 27-991763, 27-991764, 27-991762, 27-99176 V-175/V-200</p>	 <p>Pack. de 2 18-2508-1 18-2508-1-9① JUNTA PLATINA ESCAPE Reemplaza: 27-997761, 27-99776, 27-96440 V-135/V-150</p>
 <p>Pack. de 2 18-2809 18-2809-9① JUNTA TAPA Reemplaza: 27-437792, 27-437791, 27-43779, 27-96485 50-60-HP</p>	 <p>Pack. de 2 18-2511 18-2511-9① JUNTA PLATINA ESCAPE A ALOJAMIENTO Reemplaza: 27-99173-2 V-6</p>	 <p>18-60919 JUNTA TAPA ESCAPE Reemplaza: 27-834952001 Para: Mercury 8/9.9 (R042475 & Sup)</p>	 <p>Pack. de 2 18-2835 18-2835-9① JUNTA BASE BLOQUE Reemplaza: 27-692381, 27-69238, 27-66101, 27-64173, 27-60479 52-90-115-140 HP</p>	 <p>18-0982-1 JUNTA PLATINA BLOQUE Reemplaza: 27-56304, 27-48713</p>
 <p>18-60918 JUNTA BASE MOTOR Reemplaza: 27-835427003 Para: Mercury 8/9.9 (R042475 & Sup)</p>	 <p>Pack. de 2 18-0182 18-0182-9① JUNTA TERMOSTATO Reemplaza: 27-62386</p>	 <p>18-0323 JUNTA TERMOSTATO Reemplaza: 27-14318-2, 27-14318 3</p>	 <p>18-0339 JUNTA TERMOSTATO Reemplaza: 27-43006-2, 27-430066 70-90 HP</p>	 <p>18-0835 JUNTA TERMOSTATO Reemplaza: 27-824853, 27-8248531 Para: Mercury 9.9-60 H.P., 4T</p>
 <p>Pack. de 2 18-0914 JUNTA TERMOSTATO Reemplaza: 27-66847</p>	 <p>18-60920 JUNTA TERMOSTATO Reemplaza: 27-853702005 Para: Mercury 8/9.9 (R042475 & Sup)</p>	 <p>Pack. de 2 18-0936 18-0936-9① JUNTA PLATINA VÁLVULA Reemplaza: 27-78690 V-6</p>	 <p>Pack. de 2 18-0952 18-0952-9① JUNTA PLATINA VÁLVULA Reemplaza: 27-88907 V-6</p>	 <p>Pack. de 2 18-2558 18-2558-9① JUNTA IMPULSOR Reemplaza: 27-19204-2 6/8/9.9/15</p>
 <p>18-0292 JUNTA PLATINA A ALOJAMIENTO BOMBA Reemplaza: 27-81417M</p>	 <p>Pack. de 2 18-0294 18-0294-9① JUNTA PLATINA DESGASTE Reemplaza: 27-81421M</p>	 <p>Pack. de 2 18-2559 18-2559-9① JUNTA IMPULSOR Reemplaza: 27-42206, 27-19202 6/8/9.9/15</p>	 <p>Pack. de 2 18-2561 18-2561-9① JUNTA IMPULSOR Reemplaza: 27-85087 18/25 S/N 6443972 & inferior</p>	

① Precio por envase

<p>Pack. de 2</p>  <p>18-2564 JUNTA IMPULSOR 70/75/80/90/100/115 Reemplaza: 27-430331, 27-43033</p>	<p>Pack. de 2</p>  <p>18-2565 18-2565-9 ① JUNTA IMPULSOR 70/75/80/90/100/115 Reemplaza: 27-430472, 27-430471, 27-43047</p>	<p>Pack. de 2</p>  <p>18-2566 18-2566-9 ① JUNTA IMPULSOR 75/90/100/115 Reemplaza: 27-817277, 27-8172771</p>	<p>Pack. de 2</p>  <p>18-2562 18-2562-9 ① JUNTA IMPULSOR 18/20/25 S/N 6443973 & superiores Reemplaza: 27-993261, 27-99326</p>
<p>Pack. de 2</p>  <p>18-2563 18-2563-9 ① JUNTA IMPULSOR 70/75/80/90/100/115 Reemplaza: 27-430341, 27-43034</p>	<p>Pack. de 2</p>  <p>18-2801 18-2801-9 ① JUNTA BOMBA DE AGUA Reemplaza: 27-32438 4-6 Cil.</p>	<p>Pack. de 2</p>  <p>18-2823 18-2823-9 ① JUNTA BOMBA DE AGUA INFERIOR Reemplaza: 27-32769, 27-19553 40-50-70 HP</p>	<p>Pack. de 2</p>  <p>18-2824 18-2824-9 ① JUNTA BOMBA DE AGUA SUPERIOR Reemplaza: 27-32770, 27-19551</p>
<p>Pack. de 2</p>  <p>18-2825 18-2825-9 ① JUNTA BASE BOMBA DE AGUA Reemplaza: 27-32771 40-50-70</p>	<p>Pack. de 2</p>  <p>18-2826 18-2826-9 ① JUNTA BASE BOMBA DE AGUA Reemplaza: 27-85610 1, 27-85670 4</p>	<p>Pack. de 2</p>  <p>18-2827 18-2827-9 ① JUNTA BOMBA DE AGUA SUPERIOR Reemplaza: 27-39623 20 HP</p>	<p>Pack. de 2</p>  <p>18-2828 18-2828-9 ① JUNTA BOMBA DE AGUA INFERIOR Reemplaza: 27-39625 20 HP</p>
 <p>18-0622 JUNTA PLATINA INFERIOR Reemplaza: 27-19701</p>	 <p>18-2593 JUNTA BOMBA DE AGUA Reemplaza: 27-194541 Para: 45 Jet, 50HP, 55HP, 60HP 3 cil fuerabordas</p>	 <p>18-0345 JUNTA BOMBA DE AGUA Reemplaza: 27-822189 Para: 25-60HP fuerabordas, 2, 3 cil. & 4 tiempos modelo</p>	<p>Pack. de 2</p>  <p>18-2841 18-2841-9 ① JUNTA BASE BOMBA DE AGUA Reemplaza: 27-77417, 27-19552</p>

<p>Pack. de 2</p>  <p>18-2914 18-2914-9① JUNTA BOMBA AGUA Reemplaza: 27-856081, 27-85608, 27-32433, 27-30603, 27-8M0090319</p>	<p>Pack. de 2</p>  <p>18-2915 18-2915-9① JUNTA BOMBA DE AGUA Reemplaza: 27-856091, 27-858524, 27-85609, 27-32434, 27-30604</p>	<p>Pack. de 2</p>  <p>18-2919 18-2919-9① JUNTA BOMBA DE AGUA Reemplaza: 27-426311, 27-42631</p>	
 <p>18-0514 RETÉN Reemplaza: 26-25329</p>	 <p>18-0521 RETÉN Reemplaza: 26-36557</p>	 <p>18-0539 RETÉN Reemplaza: 37721</p>	
 <p>18-0563 RETÉN Reemplaza: 26-36556</p>	<p>Pack. de 2</p>  <p>18-2560 18-2560-9① JUNTA IMPULSOR Reemplaza: 12-86645, 12-866451, 8M0027721 18/20/25</p>	<p>Pack. de 5</p>  <p>18-2430 18-2430-9① 18-24301-9① (PACK. DE 50) JUNTA Reemplaza: 26-830749 Para: Todos los Verado</p>	
 <p>18-2728 RETÉN TUBO DE AGUA Reemplaza: 26-42102, 26-421021</p>	<p>Pack. de 2</p>  <p>18-2945 18-2945-9① RETÉN DRENAJE Reemplaza: 12-20260, 12-19183, 12-191832, 191833, F50556, F8077, F8186 Usado en la mayoría de las unidades inferiores y bombas de agua marina</p>	<p>Pack. de 2</p>  <p>18-2948 18-2948-9① ARANDELA GOMA Reemplaza: 12-492211, 12-49221, 12-23245 Para ventilación tanque depósito y otros usos</p>	<p>Pack. de 2</p>  <p>18-4858-9① ARANDELA Reemplaza: 12-45176 Para: Mercury fueraborda 25 H.P. y Sup, Mercruiser #1, R, MR, Alpha I Gen II y Bravo</p>

 <p>18-4261 ARANDELA Reemplaza: 19643</p>	<p>Pack. de 4</p>  <p>18-0568-9^③ CASQUILLO Reemplaza: 23-43045</p>	 <p>18-8305 JUNTA RETÉN DIVISOR Reemplaza: 26-814754, 428381, 42838, 69668, 88726</p>
 <p>18-8309 JUNTA RETÉN REGULADOR DE AGUA Reemplaza: 18717</p>	 <p>18-4698 18-46981-9^③ (Pack. de 50) ARANDELA LLENADO/VACIADO Reemplaza: 27-81987, 27-81987M</p>	 <p>18-4275 ARANDELA Reemplaza: 12-29245, 12-824793, 12-38753, 12-32733, 12-25945, 12-22388</p>



18-4858-9
ARANDELA
Reemplaza: 1 2-45176. Para Mercury fueraborda 25HP y sup. Mercruiser #1,R,MR,Alpha I GenII y colas Bravo



18-2731
OJAL
Reemplaza: 26-81607M. Para 25HP.



18-4915
CUERDA DE ARRANQUE
Reemplaza: 50-12066A9, 50-12066Q9, 50-45093, 50-28985A2, 50-22791A1, 50-12066A1



18-6506
MUELLE DE ARRANQUE
Reemplaza: 24-29340A1, T1

APLICACIONES MUELLES ARRANQUE

Modelo/HP	Desde N° de serie	Hasta N° de serie	Muelle arranque	Modelo/HP	Desde N° de serie	Hasta N° de serie	Muelle arranque
Merc 4	2498136	4107219	18-6506	Merc 35	1217222	1271884	18-6506
Merc 4.5	4107220	& Sup	18-6506	Merc 35	1356948	1448139	18-6506
Merc 6	1408611	2387383	18-6506	Merc 35	1571114	1960826	18-6506
Merc 7.5	2529895	& Sup	18-6506	Merc 35	1960827	2097279	—
Mar 8	M-677-000101	& Sup	—	Merc 35	2097832	2258863	—
Merc 9.8	Todos		18-6506	Merc 35	2300962	2453068	—
Mar 9.9	M-682-000551	M-682-032885	—	Merc 35	2487558	2874703	—
Mark (10) 10	Todos		18-6506	Merc 35	6445653	& Sup	—
Merc 10	1290910	1455239	18-6506	Mark (55) 40	831021	& Sup	18-6506
Mark (15) 15	Todos		18-6506	Merc 40	1279685	1476509	18-6506
Merc 15	1288910	1349697	18-6506	Mar 40	Todos		—
Mar 15	M-684-000101	& Sup	—	Merc 40	2874704	3336257	—
Merc 20	3537531	6443972	18-6506	Merc 40	3326258	& Sup	—
Merc 20	1292910	3537530	18-6506	Merc 40	C159200	& Sup	—
Mar 20	M-653-07615	& Inferior	—	Mark (58) 45	1139538	& Sup	18-6506
Mar 20	M-653-07616	& Sup	—	Merc 45	1476510	1531568	18-6506
Mar 20	M-6A9-000101	& Sup	—	Merc 50	1421113	2116317	18-6506
Mark (28) 22	Todos		18-6506	Merc 50	5531630	& Sup	— ②
Merc 25	1467499	1499331	18-6506	Merc 50	1770179	& Sup	—
Mar 25	M-648-19025	& Inferior	& Inferior	Mark (75) 60	Todos		18-6506
Mar 25	M-695-000101	& Sup	& Sup	Merc 60	Todos		18-6506
Mar 28	Todos		—	Merc 65	1542745	1765043	18-6506
Merc 30	1271885	1356947	18-6506	Mark (78) 70	Todos		18-6506
Mar 30	Todos		18-6521	Merc 70	Todos		18-6506

① Por encima escape ② Sólo 4 cil

③ Precio por envase

Introducing

SONAR **PRO**

SIERRA ONLINE APPLICATION RESOURCE



Login to: <http://sonar.seastarsolutions.com>

SONAR PRO FEATURES INCLUDE

- Parts Interchange
- Parts Category Search
- Model Search
- New Products
- Diagrams & Exploded Views
- Search Parts By Keyword
- Send Us Your Feedback
- Warranty Tracker
- Free

www.seastarsolutions.com

Disponible en nuestra web: www.pronautic.net

35 & 40 2 Cilindros

Serie # 2736807-G053313

50, 60, 65 3 Cilindros

Serie # 3293184-D000749

70 3 Cilindros

Serie # 4571652-6428680

40, 45, 50 4 Cilindros

Serie # 4357640 y posteriores



Figura #	Descripción	Ref #	O.E.M. #	Cant.	Figura #	Descripción	Ref #	O.E.M. #	Cant.
1	Alojamiento	—	1643-9539A1	1	48	Arandela	18-2948	12-492211	1
2	Pasador	—	17-85500	2	49	Tuerca	18-2361	11-34933	1
3	Eje dirección	—	76163A1	1	50	Tuerca	—	1134863	1
4	Clip	18-4295	53-29641	1	51	Arandela	—	12-65791	1
5	Aro	18-7153	25-21836	1	52	Arandela	—	12-45175	1
6	Casquillo	18-2155	23-77631A2	1	53	Pasador cambio	—	76039	1
7	Retén	18-2054	26-816461	1	54	Set aros	—	15-38374A1	AR
8	Arandela	18-2316	12-77674	1	55	Cojinete	18-1162	31-38356A1	1
9	Base reserva	—	78036	1	56	Cojinete	18-1096	31-21739	1
10	Cierre reverso	—	433081	1	57	Engranaje de avance	—	43-55608A4	1
11	Pivote	—	16-33778	3	58	Pasador	—	38441	1
12	Pivote	—	16-57933	2	59	Deslizador	—	20843	1
13	Tuerca piñon	—	11-55910	1	60	Muelle	—	24-38114	1
14	Engranaje piñon	—	43-98097	1	61	Pasador	—	17-38113	1
15	Cojinete	—	31-62091	1	62	Alojamiento	—	52-92911	1
16	Tornillo	—	88181	1	63	Muelle	—	24-39845	1
17	Set aros	—	15-92881A1	AR	64	Eje dirección	—	44-75365	1
18	Cojinete	—	31-77420A1	1	65	Engranaje reverso	—	43-79158	1
19	Eje dirección	—	45-981801	1	66	Arandela empuje	—	12-32004	1
20	Muelle	—	24-20254	1	67	Set aros	—	15-20927A1	AR
21	Pasador	—	17-30545	1	68	Cojinete	18-1190	30-20839T	1
22	Junta	18-2841	27-19552	1	69	Aro	18-7160	2531986	1
23	Aro	18-7115	25-26722	1	70	Soporte cojinete	—	69386A1	1
24	Retén	18-2055	26-79831	1	71	Llave	—	28-30281	1
25	Retén	18-2011	26-90562	1	72	Cojinete	—	3121700	1
26	Base bomba de agua	18-3424	46-77177A1	1	73	Retenes	18-2051, 18-2052	26-69188, 26-619189	1
27&28	Pasador	—	17-35973	1	74	Arandela	—	14-53012	1
29	Junta	18-2823	27-19553	1	75	Tuerca tapa	—	11-87763	1
30	Platina	18-3107	54705	1	76	Núcleo de empuje	18-4233	73345A1	1
31	Llave	—	28-56662	1	77	Núcleo empuje	18-3204	14-76281	1
32	Junta	18-2824	27-19551	1	78	Núcleo empuje	18-3204	14-76281	1
33	Impulsor	18-3007	47-89983	1	79	Tuerca	18-3702	11-69578A	1
34	Aro pasante	18-3115	48753	1	80	Kit retén alojamiento	18-2654	26-79831A1	1
35	Cuerpo bomba de agua	18-3118	46-77822A1	1	81	Kit reparación bomba de agua	18-3324	46-77177A3	1
36	Arandela	—	12-38453	1					
37	Retén	—	26-38452	1					
38	Tuerca	—	25-20273	1					
39	Arandela	18-4275	12-29245	3					
40	Tuerca	—	11-13438	3					
41	Anodo zinc	009354	31640A1	1					
42	Tornillo	—	10-66024	1					
43	Soporte platina	—	92815	1					
44	Retén tubo de salida	18-0539	37721	1					
45	Tapón drenaje	18-2244	10-79953	2					
46	Arandela	18-2945	12-19183	2					
47	Tapón	—	19-48750	1					
AR Se requiere									

70, 75, 80, 90

Serie # A996142 y posterior

100, 115, 125 4 Cilindros

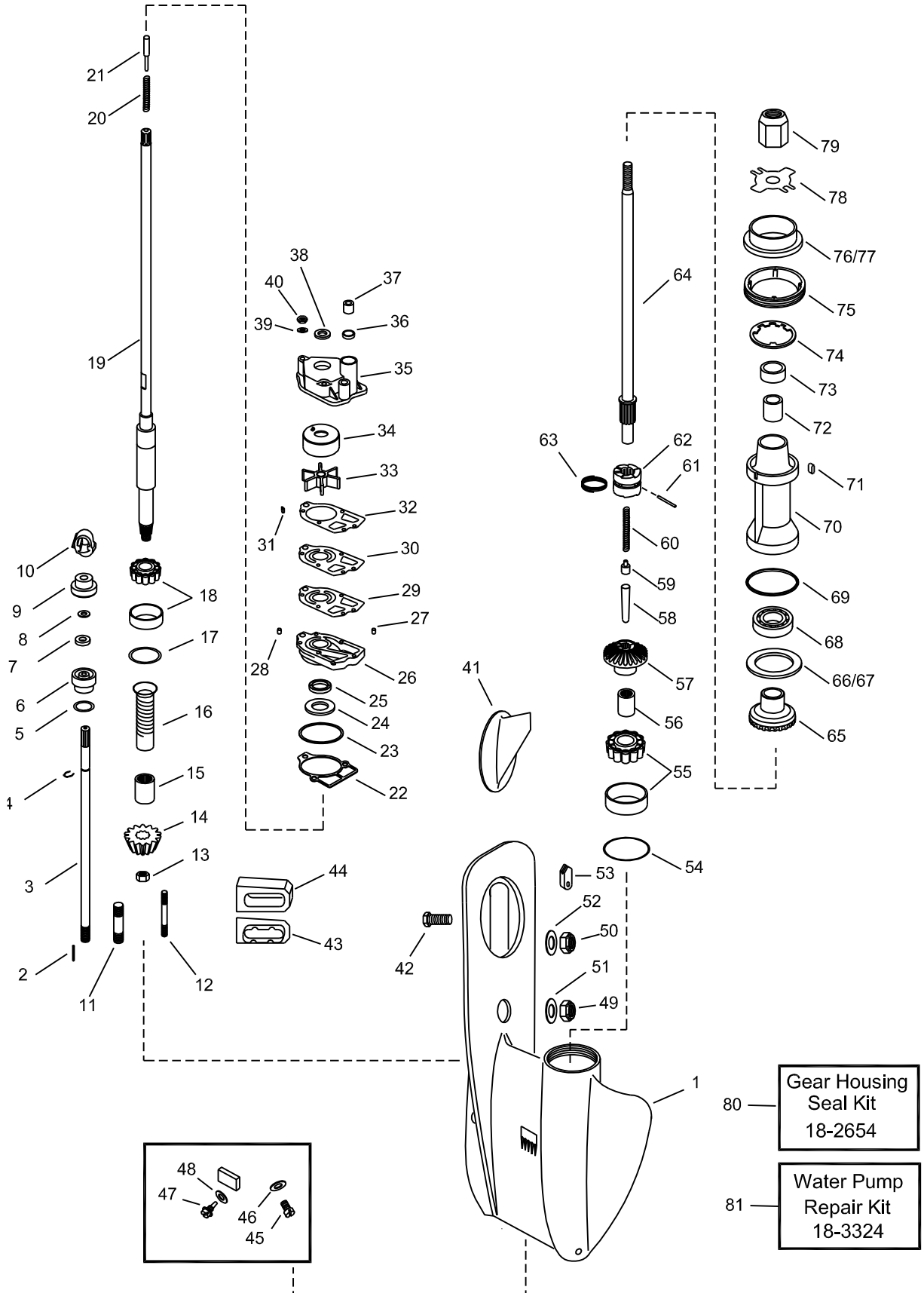
Serie # B209468 y posterior

- 68 — Gear Housing Seal Kit 18-2626
- 69 — Water Pump Repair Kit 18-3214



Figura #	Descripción	Ref #	O.E.M. #	Cant.	Figura #	Descripción	Ref #	O.E.M. #	Cant.
1	Alojamiento	—	1667-9011A73	1	49	Muelle	—	24-30622	1
2	Tornillo	—	10-8248327	4	50	Embrague	18-2236	52-822539	1
3	Arandela	18-4275	12-29245	4	51	Pasador	18-2357	17-30632	1
4	Aislador	18-0568	23-43045	4	52	Muelle	18-2348	24-30893	1
5	Aloj. bomba agua	18-3572	817275A2	1	53	Eje dirección	—	44-12238T	1
6	Impulsor 18-3056S	18-3056	47-430262	1	54	Engranaje reverso	—	43-12635	1
7	Impulsor llave	18-3293	28-43037	1	55	Aro	18-7961	25-97386	1
8	Junta	18-2566	27-817277	1	56	Cojinete	18-1112	31-12576	1
9	Platina	18-3122	817276	1	57	Arandela empuje	18-1191	12-12577	1
10	Junta	18-2564	27-430331	1	58	Cojinete	18-1113	31-12578	1
11	tornillo	—	10-824832-6	6	59	Soporte cojinete	—	12596A2	1
12	Arandela	18-4275	12-29245	6	60	Arandela	—	12-70132	2
13	base bomba	—	43055A4	1	61	Tuerca	—	11-401198	2
14	Retén	18-0583	26-43035	1	62	Cojinete	18-1158	31-30956	1
15	Retén	18-0522	26-43036	1	63	Retén	18-2002	26-76868	1
16	Junta	18-2565	27-430472	1	64	Retén	18-2053	26-70081	1
17	Eje	—	43040A1	1	65	Arandela empuje	18-4221	13191A1	1
18	Tornillo	—	43046	1	66	Arandela	18-3200	14-31210	1
19	Alojamiento	—	42461A1	1	67	Tuerca hélice	18-3700	11-52707	1
20	Alojamiento	—	42461A1	1					
21	Eje dirección	—	45-43031A1	1					
22	Aro	—	15-44492A1	AR					
23	Cojinete (Se vende con #24)	18-1118	31-42677A1	1					
24	Cojinete (Se vende con #23)	18-1118	31-42677A1	1					
25	Piñon engranaje	—	43-44484	1					
26	Tuerca piñon	18-3719	11-35921	1					
27	Retén	18-2054	26-8164641	1					
28	Alojamiento	—	23-43052A4	1					
29	Tornillo	—	10-824832-6	2					
30	Aro	18-7198	25-45710	1					
31	Aro	18-4295	53-29641	1					
32	Eje	—	43048A1	1					
33	Junta	18-2945	12-19183	3					
34	Tapón	—	10-28653	1					
35	Tapón	18-2244	10-79953	1					
36	Tapón	18-2375	22-67892A1	1					
37	Anodo zinc	009354	31640A1	1					
38	Tornillo montaje ánodo	18-6245	10-15942	1					
39	Arandela, montaje ánodo	18-4858-9	12-45176	1					
40	Leva	—	76039	1					
41	Arandela	—	15-44491A1	AR					
42 & 43	Cojinete	18-1156	13-30894A1	1					
44	Cojinete	18-1157	31-30895	1					
45	Engranaje avante	—	43-12634A2	1					
46 & 47	Pasador	—	12239A1	1					
48	Cojiente	—	30-44530	3					

AR Se requiere

V-150

Serie # A904645 y anteriores

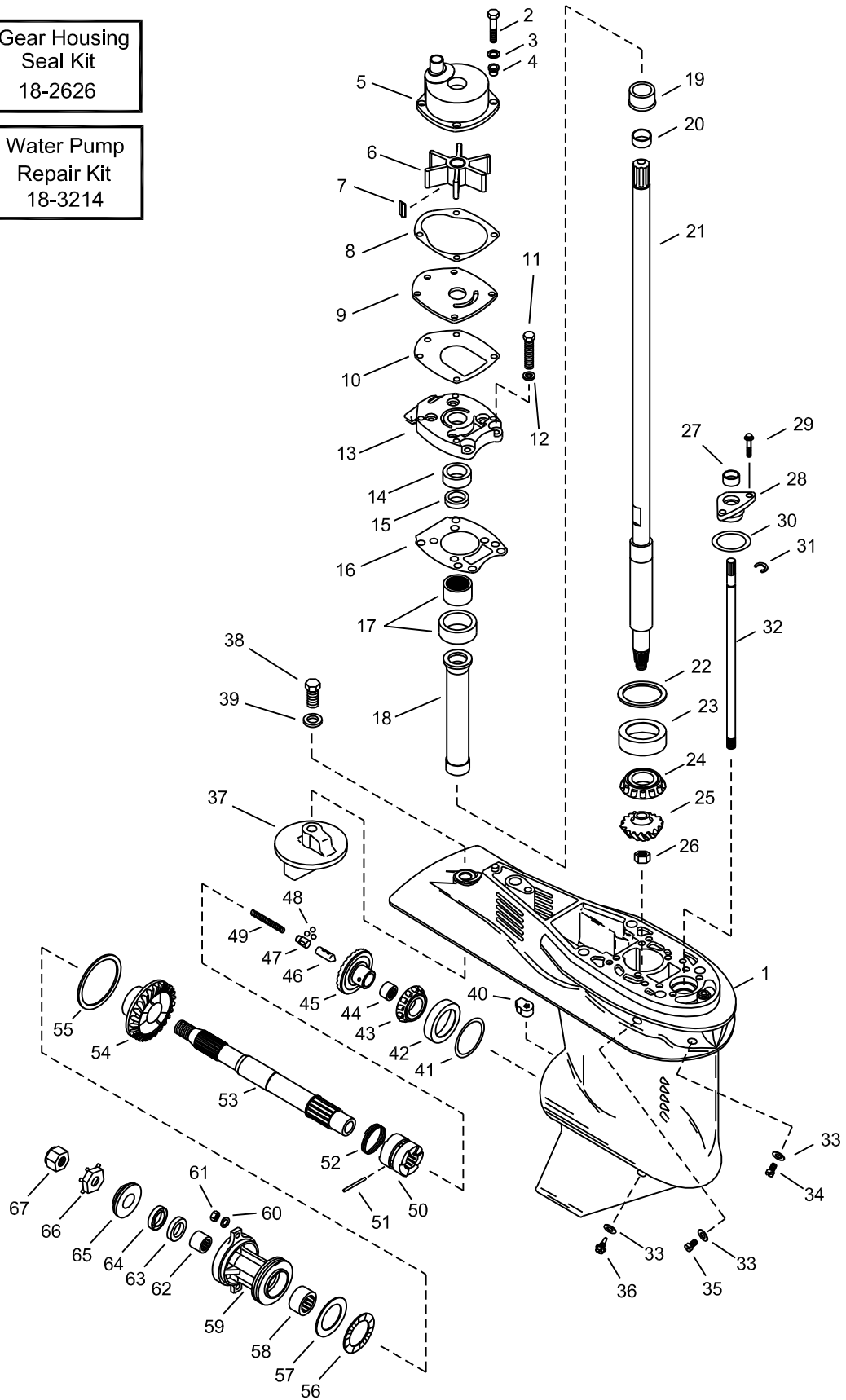
V-175

Serie # 6648750 y anteriores

V-200

Serie # 6625220 y anteriores

86— Gear Housing Seal Kit
18-2653

87— Water Pump Repair Kit
(with housing)
18-3217

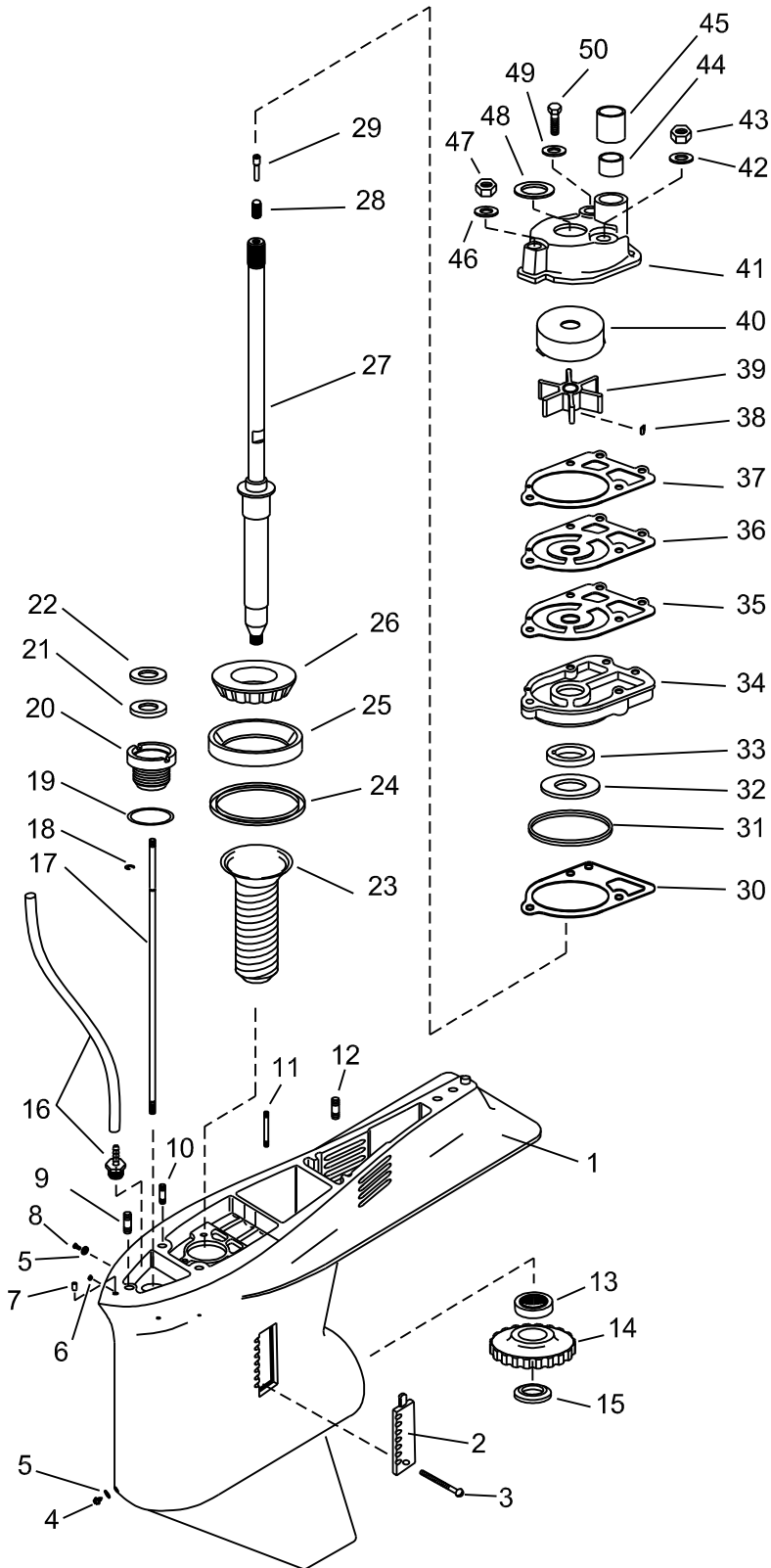

Listado completo de engranajes en la página 101



Figura #	Descripción	Ref #	O.E.M. #	Cant.
34	Base bomba de agua	18-3416	46-96146A6	1
35	Junta	18-2914	27-856081	1
36	Platina	18-3117	32435	1
37	Junta	18-2915	27-856091	1
38	Llave	~	28-56654	1
39	Impulsor 18-3017S	18-3017	47-899842	1
40	Aro pasante	18-3114	48752	1
41	Cuerpo bomba de agua	18-3116	43-96148A1	1
42	Arandela	18-4275	12-29245	3
43	Tuerca	18-3722	11-20361	2
44	Retén	18-3110	26-38970	1
45	Guía	18-3109	23-29804	1
46	Arandela	18-4270	12-36001	1
47	Aro	18-3722	11-45592	1
48	Aro	18-7426	25-30271	1
49	Arandela	18-4275	12-29245	3
50	Tornillo	~	10-96411	1
51	Ánodo Trim.	009354	3164A1	1
52	Tornillo	~	10-66024	1
53	Pasador cambio	~	78956	1
54	Tuerca	18-3721	11-34933	1
55	Arandela	~	12-45176	2
56	Tornillo	~	10-65210	1
57	Pasador	~	89594A1	1
58	Actuador	~	79911 1	1
59	Pasador	~	17-78906	1
60	Muelle	~	24-749910	2
61	Arandela	~	12-78910	1
62	Arandela	18-2285	15-47397A1	AR
63	Cojinete	18-1166	31-78172A1	1
64	Engranaje de avance	~	43-78082A3	1
65	Cojinete	18-1122	31-73363	2
66	Embrague	~	52-823174	1
67	Pasador	~	17-78909	2
68	Pasador	~	17-78905	1
69	Muelle	~	24-78962	2
70	Eje dirección	18-2239	44-94148	1
71	Engranaje reverso	~	43-85462	1
72	Aro	~	68100 1	1
73	Cojinete	18-1155	30-88957	1
74	Aro	18-7159	25-31534	1
75	Cojinete soporte	18-1567	43567T1	1
76	Llave	~	28-30281	1
77	Cojinete	18-1158	31-30956	1
78	Retén (Int)	18-2002	26-76868	1
79	Retén (Ext)	18-2053	26-70081	1
80	Arandela	18-2299	14-79447	1
81	Tuerca tapa	18-3751	79448	1
82	Núcleo empuje	18-4220	13171	1
83	Arandela	18-3714	12-31211A2	1
84	Arandela	18-3200	14-31210	1
85	Tuerca hélice	18-3700	11-52707	1

Figura #	Descripción	Ref #	O.E.M. #	Cant.
1	Alojamiento	~	1647-9148A65	1
2	Rejilla de agua (Estridor)	~	66885	1
	Rejilla de agua (Babor)	~	66884	1
3	Tornillo	18-3197	10-76156	1
4	Tornillo drenaje	18-2375	22-67892A1	1
5	Arandela	18-2945	12-19183	2
6	Tuerca	18-2344	11-45812	1
7	Pasador	~	17-43044	2
8	Tornillo ventilación	18-2244	10-79953	1
9	Pivote	~	16-78638	1
10	Pivote	~	16-56297	1
11	Pivote	~	16-30667	2
12	Pivote	~	16-579201	2
13	Cojinete	~	31-35934A1	1
14	Piñon engranaje	~	43-780811	1
15	Tuerca piñon	18-3719	11-35921	1
16	Tubo velocímetro	~	22-85822A10	1
17	Eje dirección	~	78902 2	1
18	Clip	18-4295	53-29641	1
19	Aro	18-7153	25-21836	1
20	Casquillo	18-2155	23-77631A2	1
21	Retén	18-2054	26-816461	1
22	Arandela goma	18-2316	12-77674	1
23	Tornillo	~	23-98621	1
24	Arandela	18-2295	15-57007A1	AR
25	Cojinete	18-1164	31-53079A1	1
26	Cojinete	18-1164	31-53079A1	1
27	Eje dirección	~	45-98682A1	1
28	Muelle	~	24-34576	1
29	Pasador	~	17-30545	1
30	Junta	18-2826	27-856101	1
31	Aro	18-7162	25-33145	1
32	Retén	18-2014	26-89238	1
33	Retén	18-2013	26-16977	1

AR Se requiere

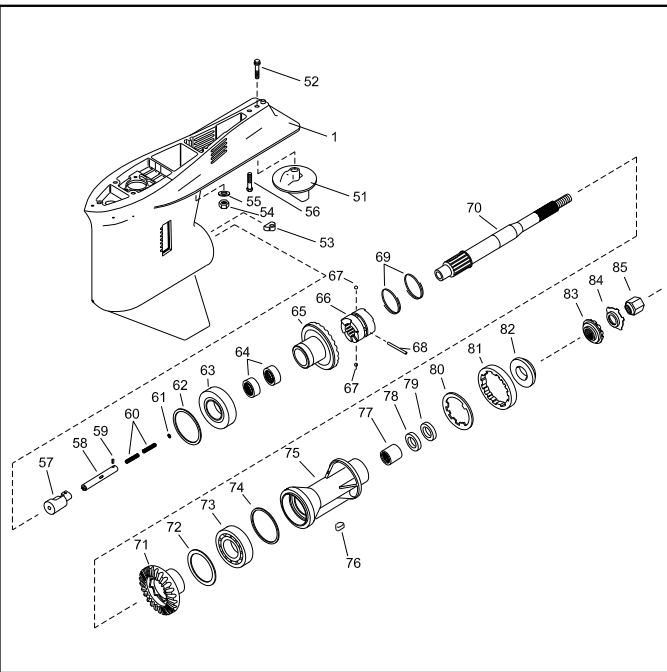

18-1190
COJINETE A BOLAS
Reemplaza: 30-20839T, 30-20839, 30-62699, FI000034
Para engranaje reverso Force, Mercury, Mariner de 25-60HP (2, 3 cilindros, & 4-tiempos) incluye 30Jet - 45Jet



18-1191
ARANDELA EMPUJE
Reemplaza: 12-12577
30-125HP



18-1111
COJINETE ENGRANAJE REVERSO
Reemplaza: 31-62799A1



18-1112
COJINETE DE EMPUJE ENGRANAJE REVERSO
Reemplaza: 31-12576



18-1113
COJINETE ENGRANAJE REVERSO
Reemplaza: 31-12578, 31-12578T



18-1115
COJINETE PIÑON AVANTE INT.
Reemplaza: 31-32898, 31-32898T, 31-29982



18-1117
COJINETE PIÑON
Reemplaza: 31-42647A1, 31-42647, 31-F694057



18-1118
COJINETE PIÑON
Reemplaza: 31-42677A1



18-1122
COJINETE INTERIOR ENGRANAJE AVANTE
Reemplaza: 31-73363, 31-73363T



18-1143
COJINETE CÓNICO
Reemplaza: 31-36387A1



18-1347
COJINETE PRINCIPAL
Reemplaza: 31-88269T. PARA: 250/275/3.4L



18-1153
COJINETE A BOLAS
Reemplaza: 30-63326, 30-63326T, 30-49313, 30-54215, 30-20464



18-1154
COJINETE A BOLAS
Reemplaza: 30-63742, 30-63742T



18-1155
COJINETE A BOLA
Reemplaza: 30-88957A1, 30-88957T, 30-35914, 30-17927, 30-89957



18-1197
COJINETE CÓNICO
Reemplaza: 31-828439A2
1.5625 D.I.
Para: Mercury/Mariner 200 (3.0L DFI), 225 (3.0L Carb), 225/250 (3.0L EFI) S/N G437999 & inferior



18-1156
COJINETE RODILLO
Reemplaza: 31-30894A1



18-1157
COJINETE AGUJAS
Reemplaza: 31-30895, 31-30895T



18-1158
COJINETE DE AGUJAS
Reemplaza: 31-30956, 31-30956T, 31-F523058



18-1159
COJINETE RODILLOS
Reemplaza: 31-35928A1, 31-35928T1



18-1162
COJINETE RODILLOS
Reemplaza: 31-38356A1, 31-F84901, FA84901, F84903



18-1164
COJINETE RODILLOS
Reemplaza: 31-53079A1, 31-53079

18-1166
COJINETE RODILLOS
Reemplaza: 31-78172A1

18-1163
COJINETE RODILLOS
Reemplaza: 31-48941A1

18-1170
COJINETE PIÑÓN INFERIOR
Reemplaza: 31-812767A1



18-0557
RETÉN INFERIOR
Reemplaza: 888909A1
Para: Todos Verado
135/150/175/200/225/250/275



18-1126
COJINETE RODILLOS
Reemplaza: 31-54036A1

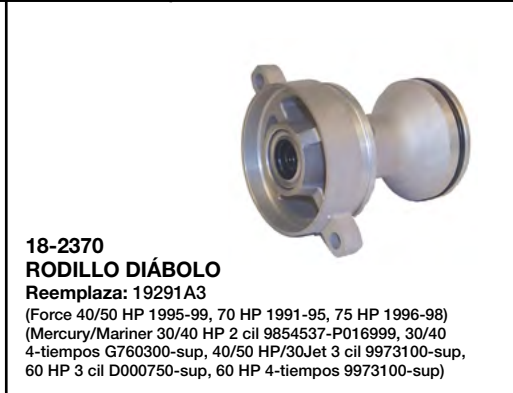

18-2370
RODILLO DIÁBOLO
Reemplaza: 19291A3
(Force 40/50 HP 1995-99, 70 HP 1991-95, 75 HP 1996-98)
(Mercury/Mariner 30/40 HP 2 cil 9854537-P016999, 30/40
4-tiempos G760300-sup, 40/50 HP/30Jet 3 cil 9973100-sup,
60 HP 3 cil D000750-sup, 60 HP 4-tiempos 9973100-sup)

Modelo	Número de serie	Cojinete (Eje transmisión)	Cojinete piñón	Cojinete interior marcha adelante	Cojinete externo Marcha adelante	Cojinete Marcha atrás	Cojinete empuje Marcha atrás	Cojinete Agujas
30 (4-tiempos, Bigfoot)	G760300 & Sup	18-1118	—	18-1157	18-1156	18-1113	18-1112	18-1158
30 (4-tiempos, no-Bigfoot)	G760300 & Sup	—	—	—	18-1107	—	—	—
30 EFI (4-tiempos, Bigfoot)	T409000 & Sup	18-1118	—	18-1157	18-1156	18-1113	18-1112	18-1158
30 EFI (4-tiempos, no-Bigfoot)	T409000 & Sup	—	—	—	18-1107	—	—	—
35 (2 cil.)	6445653 & Sup	—	—	—	18-1162	—	N/D	—
350	1960827 - 2874703	—	—	18-1162	—	N/D	—	—
400 (2 cil.)	2874704 - 3336257	—	—	—	18-1162	—	N/D	—
402	3336258 - 4117709	—	—	—	18-1162	—	N/D	—
402	4117710 - 4860102	—	—	—	18-1162	—	N/D	—
402/40 (2 cil.)	4860103 - 5556229	—	—	—	18-1162	—	N/D	—
40 (2 cil.)	5556230 - G053313	—	—	—	18-1162	—	N/D	—
40 (4 cil.)	C159200 & Sup	—	—	—	18-1162	—	N/D	—
40 (4-tiempos, Bigfoot)	G231123 & Sup	18-1118	—	18-1157	18-1156	18-1113	18-1112	18-1158
40 (4-tiempos, no-Bigfoot)	G231123 & Sup	—	—	—	18-1107	—	—	—
40 (4-tiempos, 4 cil. Bigfoot)	T228405 & Sup	18-1118	—	18-1157	18-1156	18-1113	18-1112	18-1158
40 (4-tiempos, 4 cil. no-Bigfoot)	T228405 & Sup	—	—	—	18-1170	—	—	—
40 EFI (4-tiempos, 3 cil. no-Bigfoot)	T409000 & Sup	—	—	—	18-1103	18-1190	—	—
40 EFI (4-tiempos, 3 cil. Bigfoot)	T409000 & Sup	18-1118	—	18-1157	18-1156	18-1113	18-1112	18-1158
40 EFI (4-tiempos, 4 cil. no-Bigfoot)	T409000 & Sup	—	—	—	18-1170	—	—	—
45 (4 cil.)	5531630 & Sup	—	—	—	18-1162	—	N/D	—
45 (Bodensee 4-tiempos, Bigfoot)	G231123 - T178499	18-1118	—	18-1157	18-1156	18-1113	18-1112	18-1158
45 (Bodensee 4-tiempos, no-Bigfoot)	G231123 - T178499	—	—	—	18-1103	—	—	—
500	2305101 - 2858813	—	—	—	18-1162	—	N/D	—
500	2858814 - 4140999	—	—	—	18-1162	—	N/D	—
500	4141000 - 4357639	—	—	—	18-1162	—	N/D	—
500 / 50	4357640 - 4962055	—	—	—	18-1162	—	N/D	—
500 / 50	4962056 - 5531629	—	—	—	18-1162	—	N/D	—
50 (4 cil.)	5531630 & Sup	—	—	—	18-1162	—	N/D	—
50 (3 cil.)	6428681 - D000749	—	—	—	18-1162	—	N/D	—
50 (3 cil.)	D000750 - G589999	—	—	—	18-1170	—	N/D	—
50 (4-tiempos, Bigfoot)	G231123 & Sup	18-1118	—	18-1157	18-1156	18-1113	18-1112	18-1158
50 (4-tiempos, no-Bigfoot)	G231123 & Sup	—	—	—	18-1107	—	—	—

- ① Sólo rotación standar.
- ② Para unidades con número 1655-9572C.
- ③ Para unidades con número 1674-814247C.
- ④
- ⑤ Necesita 2 cojinetes.
- ⑥ Para 5/8 Cojinete doble.
- ⑦ Use 18-1155 para aplicaciones contra-rotación.

Modelo	Número de serie	Cojinete (Eje transmisión)	Cojinete Piñón	Cojinete interior Marcha avante	Cojinete exterior Marcha avante	Cojinete marcha atrás	Cojinete empuje Marcha atrás	Cojinete Agujas
30 (4-tiempos, Bigfoot)	G760300 & Sup	18-1118	—	18-1157	18-1156	18-1113	18-1112	18-1158
30 (4-tiempos, no-Bigfoot)	G760300 & Sup	—	—	—	18-1107	—	—	—
30 EFI (4-tiempos, Bigfoot)	T409000 & Sup	18-1118	—	18-1157	18-1156	18-1113	18-1112	18-1158
30 EFI (4-tiempos, no-Bigfoot)	T409000 & Sup	—	—	—	18-1107	—	—	—
35 (2 cil.)	6445653 & Sup	—	—	—	18-1162	—	N/D	—
350	1960827 - 2874703	—	—	18-1162	—	N/D	—	—
400 (2 cil.)	2874704 - 3336257	—	—	—	18-1162	—	N/D	—
402	3336258 - 4117709	—	—	—	18-1162	—	N/D	—
402	4117710 - 4860102	—	—	—	18-1162	—	N/D	—
402/40 (2 cil.)	4860103 - 5556229	—	—	—	18-1162	—	N/D	—
40 (2 cil.)	5556230 - G053313	—	—	—	18-1162	—	N/D	—
40 (4 cil.)	C159200 & Sup	—	—	—	18-1162	—	N/D	—
40 (4-tiempos, Bigfoot)	G231123 & Sup	18-1118	—	18-1157	18-1156	18-1113	18-1112	18-1158
40 (4-tiempos, no-Bigfoot)	G231123 & Sup	—	—	—	18-1107	—	—	—
40 (4-tiempos, 4 cil. Bigfoot)	T228405 & Sup	18-1118	—	18-1157	18-1156	18-1113	18-1112	18-1158
40 (4-tiempos, 4 cil. no-Bigfoot)	T228405 & Sup	—	—	—	18-1170	—	—	—
40 EFI (4-tiempos, 3 cil. no-Bigfoot)	T409000 & Sup	—	—	—	18-1103	18-1190	—	—
40 EFI (4-tiempos, 3 cil. Bigfoot)	T409000 & Sup	18-1118	—	18-1157	18-1156	18-1113	18-1112	18-1158
40 EFI (4-tiempos, 4 cil. no-Bigfoot)	T409000 & Sup	—	—	—	18-1170	—	—	—
45 (4 cil.)	5531630 & Sup	—	—	—	18-1162	—	N/D	—
45 (Bodensee 4-tiempos, Bigfoot)	G231123 - T178499	18-1118	—	18-1157	18-1156	18-1113	18-1112	18-1158
45 (Bodensee 4-tiempos, no-Bigfoot)	G231123 - T178499	—	—	—	18-1103	—	—	—
500	2305101 - 2858813	—	—	—	18-1162	—	N/D	—
500	2858814 - 4140999	—	—	—	18-1162	—	N/D	—
500	4141000 - 4357639	—	—	—	18-1162	—	N/D	—
500 / 50	4357640 - 4962055	—	—	—	18-1162	—	N/D	—
500 / 50	4962056 - 5531629	—	—	—	18-1162	—	N/D	—
50 (4 cil.)	5531630 & Sup	—	—	—	18-1162	—	N/D	—
50 (3 cil.)	6428681 - D000749	—	—	—	18-1162	—	N/D	—
50 (3 cil.)	D000750 - G589999	—	—	—	18-1170	—	N/D	—
50 (4-tiempos, Bigfoot)	G231123 & Sup	18-1118	—	18-1157	18-1156	18-1113	18-1112	18-1158
50 (4-tiempos, no-Bigfoot)	G231123 & Sup	—	—	—	18-1107	—	—	—
50 EFI (4-tiempos, no-Bigfoot)	T409000 & Sup	—	—	—	18-1107	—	—	—
50 EFI (4-tiempos, Bigfoot)	T409000 & Sup	18-1118	—	18-1157	18-1156	18-1113	18-1112	18-1158
55 (3 cil.)	D000750 - G589999	—	—	—	18-1170	—	N/D	—
55 Seapro, Marathon, Pontoon	D000750 & Sup	18-1118	—	18-1157	18-1156	18-1113	18-1112	18-1158
60 (3 cil.)	6428681 - D000749	—	—	—	18-1162	—	N/D	—
60 (3 cil.)	D000750 - G589999	—	—	—	18-1170	—	N/D	—
60 EFI (4-tiempos, no-Bigfoot)	T409000 & Sup	—	—	—	18-1103	—	—	—
60 EFI (4-tiempos, Bigfoot)	T409000 & Sup	18-1118	—	18-1157	18-1156	18-1113	18-1112	18-1158
650 (4 cil.)	1542745 - 1765403	18-1153	—	18-1157	18-1156	—	N/D	18-1158
650 (4 cil.)	2119749 - 2309310	18-1153	—	18-1157	18-1156	—	N/D	18-1158
650 (4 cil.)	2309311 - 2452709	18-1153	—	18-1157	18-1156	—	N/D	18-1158
650 (4 cil.)	2503991 - 2803561	18-1153	—	18-1157	18-1156	—	N/D	18-1158
650 (4 cil.)	2803562 - 2874263	—	—	18-1157	18-1156	—	N/D	18-1158
650 (4 cil.)	2997339 & Sup	—	—	18-1157	18-1156	—	N/D	18-1158
650 (3 cil.)	3293184 - 3525440	—	—	—	18-1162	—	N/D	—
650 (3 cil.)	3547987 - 4571651	—	—	—	18-1162	—	N/D	—
70 (3 cil.)	4571652 - 4977156	—	—	—	18-1162	—	N/D	—
70 (3 cil.)	4977157 - 5579016	—	—	—	18-1162	—	N/D	—
70 (3 cil.)	5579017 - 6428680	—	—	—	18-1162	—	N/D	—
70 (3 cil.)	A996142 - & Sup	18-1118	N/D	18-1157	18-1156	18-1113	18-1112	18-1158
75 (4 cil.)	6432901 & Sup	—	—	18-1157	18-1156	N/D	N/D	18-1158
75 (3 cil.)	A996142 - & Sup	18-1118	N/D	18-1157	18-1156	18-1113	18-1112	18-1158
800 (4 cil.)	2559001 - 3144218	18-1153	—	18-1157	18-1156	—	N/D	18-1158
800 (4 cil.)	3144219 - 3493912	—	—	18-1157	18-1156	—	N/D	18-1158
80 (4 cil.)	4831999 - 6432900	—	—	18-1157	18-1156	N/D	N/D	18-1158
80 (3 cil.)	A996142 & Sup	18-1118	N/D	18-1157	18-1156	18-1113	18-1112	18-1158
850 (4 cil.)	3493913 - 4831998	—	—	18-1157	18-1156	—	N/D	18-1158
900 (6 cil.)	1766824 - 1869775	18-1153	—	18-1157	18-1156	—	N/D	18-1158
900/90 (6 cil.)	4845301 - & Sup	—	—	18-1157	18-1156	N/D	N/D	18-1158
90 (3 cil.)	A996142 & Sup	18-1118	N/D	18-1157	18-1156	18-1113	18-1112	18-1158

① Sólo rotación standar.

③ Para unidades con número 1655-9572C.

④ Para unidades con número 1674-814247C.

⑤ Necesita dos cojinetes.

⑥ Para 5/8 cojinete doble.

⑦ Use 18-1155 para aplicaciones contra-rotación.

⑧ Usar piñón 43-19672.

Modelo	Número de serie	Cojinete (eje transmisión)	Cojinete piñón	Cojinete inferior Marcha adelante	Cojinete externo Marcha adelante	Cojinete marcha atrás	Cojinete empuje marcha atrás	Cojinete Agujas
100 (4 cil.)	B209468 - & Sup	18-1118	N/D	18-1157	18-1156	18-1113	18-1112	18-1158
1150	2836019 - 2933900	18-1153	—	18-1157	18-1156	—	N/D	18-1158
1150	2933901 - 3525440	18-1153	—	18-1157	18-1156	—	N/D	18-1158
1150	3525441 - 4112634	18-1153	—	18-1157	18-1156	—	N/D	18-1158
1150	4112635 - 4855152	—	—	18-1157	18-1156	—	N/D	18-1158
1150 / 115	4855153 - 5314655	—	—	18-1157	18-1156	N/D	N/D	18-1158
115 (6 cil.)	5314656 - 5600966	—	—	18-1157	18-1156	N/D	N/D	18-1158
115 (6 cil.)	5600967 - 6436122	—	—	18-1157	18-1156	N/D	N/D	18-1158
115 (6 cil.)	6436123 & Sup	—	—	18-1157	18-1156	N/D	N/D	18-1158
115 (4 cil.)	C100000 & Sup	18-1118	N/D	18-1157	18-1156	18-1113	18-1112	18-1158
125 (4 cil.)	0T627234 & inferior ⑥	18-1118	N/D	18-1157	18-1156	18-1113	18-1112	18-1158
1250	2314956 - 2839368	18-1153	—	18-1157	18-1156	—	N/D	18-1158
1350	2839369 - 2940020	18-1153	—	18-1157	18-1156	—	N/D	18-1158
1350	2940021 - 3293233	18-1153	—	18-1157	18-1156	—	N/D	18-1158
1400	3293234 - 3502805	18-1153	—	18-1157	18-1156	—	N/D	18-1158
140	4865687 & Sup	—	—	18-1157	18-1156	N/D	N/D	18-1158
1500	3502806 - 4121434	18-1153	—	18-1157	18-1156	—	N/D	18-1158
1500	4121435 - 4865677	—	—	18-1157	18-1156	—	N/D	18-1158
V-135	A904646 & Sup	18-1143	18-1117	18-1122 ⑤	18-1166	18-1155	N/D	18-1158
V-135	C100861 & Sup	18-1143	18-1117	18-1122 ⑤ ①	18-1166 ① ⑦	18-1155 ①	N/D	18-1158
V-135	C239553 & Sup	18-1143	18-1117	18-1122 ⑤ ①	18-1166 ① ⑦	18-1155 ①	N/D	18-1158
V-135	D082000 & Sup	18-1143	18-1117	18-1115 ①	18-1166 ① ⑦	18-1155 ①	N/D	18-1158
V-150	4868998 - 5432021	18-1164	—	18-1122 ⑤	18-1166	18-1155	N/D	18-1158
V-150	5432022 - 6042945	18-1164	—	18-1122 ⑤	18-1166	18-1155	N/D	18-1158
V-150	6042946 - 6443212	18-1164	—	18-1122 ⑤	18-1166	18-1155	N/D	18-1158
V-150	6443213 - 6616990	18-1164	—	18-1122 ⑤	18-1166	18-1155	N/D	18-1158
V-150	6616991 - A904645	18-1164	—	18-1122 ⑤	18-1166	18-1155	N/D	18-1158
V-150	A904646 & Sup	18-1143	18-1117	18-1122 ⑤	18-1166	18-1155	N/D	18-1158
V-150	C100861 & Sup	18-1143	18-1117	18-1122 ⑤ ①	18-1166 ①	18-1155	N/D	18-1158
V-150	C239553 & Sup	18-1143	18-1117	18-1122 ⑤ ①	18-1166 ① ⑦	18-1155 ①	N/D	18-1158
V-150	D082000 & Sup	18-1143	18-1117	18-1115 ①	18-1166 ① ⑦	18-1155 ①	N/D	18-1158
V-150XRI (EFI)	D082000 & Sup	18-1143	—	18-1157	18-1156 ①	N/D	N/D	18-1158
V-150XRI (EFI)	D082000 & Sup	18-1143	18-1117	18-1115 ⑤ ①	18-1166 ① ⑦	18-1155 ①	N/D	18-1158
V-150XRI (EFI)	D082000 & Sup	18-1143	18-1117	18-1115 ⑤ ①	18-1166 ① ⑦	18-1155 ①	N/D	18-1158
V-175	4301235 - 5393736	18-1164	—	18-1122 ⑤	18-1166	18-1155	N/D	18-1158
V-175	5393737 - 6618750	18-1164	—	18-1122 ⑤	18-1166	18-1155	N/D	18-1158
V-175	6618751 & Sup	18-1143	18-1117	18-1122 ⑤	18-1166	18-1155	N/D	18-1158
V-175	C100861 & Sup	18-1143	18-1117	18-1122 ⑤ ①	18-1166 ① ⑦	18-1155 ①	N/D	18-1158
V-175	C239553 & Sup	18-1143	18-1117	18-1122 ⑥ ①	18-1166 ① ⑦	18-1155 ①	N/D	18-1158
V-175	D082000 & Sup	18-1143	18-1117	18-1115 ①	18-1166 ① ⑦	18-1155 ①	N/D	18-1158
V-175XRI (EFI)	D000750 & Sup	18-1143	18-1117	18-1122 ⑤ ⑥	18-1166	18-1155	N/D	18-1158
V-175XRI (EFI)	D000750 & Sup	18-1143	18-1117	18-1122 ⑤ ⑥	18-1166	18-1155	N/D	18-1158
V-175XRI (EFI)	D082000 & Sup	18-1143	—	18-1157	18-1156 ①	N/D	N/D	18-1158
V-175XRI (EFI)	D082000 & Sup	18-1143	18-1117	18-1115 ⑤ ①	18-1166 ① ⑦	18-1155 ①	N/D	18-1158
V-175XRI (EFI)	D082000 & Sup	18-1143	18-1117	18-1115 ⑤ ①	18-1166 ① ⑦	18-1155 ①	N/D	18-1158
V-200	4839034 - 5363917	18-1164	—	18-1122 ⑤	18-1166	18-1155	N/D	18-1158
V-200	5363918 - 6073191	18-1164	—	18-1122 ⑤	18-1166	18-1155	N/D	18-1158
V-200	6073192 - 6203990	18-1164	—	18-1122 ⑤	18-1166	18-1155	N/D	18-1158
V-200	6203991 - 6435502	18-1164	—	18-1122 ⑤	18-1166	18-1155	N/D	18-1158
V-200	6435503 - 6625220	18-1164	—	18-1122 ⑤	18-1166	18-1155	N/D	18-1158
V-200	6625221 - C100860	18-1143	18-1117	18-1122 ⑤	18-1166	18-1155	N/D	18-1158
V-200								
V-200 (EFI)	C100861 - C291519	18-1143	18-1117	18-1122 ⑤	18-1166	18-1155	N/D	18-1158
V-200 (2.5L)	C291520 - D081999	18-1143	18-1117	18-1122 ⑥ ①	18-1166 ① ⑦	18-1155 ①	N/D	18-1158
V-200	D082000 & Sup	18-1143	18-1117	18-1115 ①	18-1166 ① ⑦	18-1155 ①	N/D	18-1158
V-200XRI (EFI)	C291520 & Sup	18-1143	18-1117	18-1122 ⑤	18-1166	18-1155	N/D	18-1158
V-200XRI (EFI)	D082000 & Sup	18-1143	—	18-1157	18-1156 ①	N/D	N/D	18-1158
V-200XRI (EFI)	D082000 & Sup	18-1143	18-1117	18-1115 ⑤ ①	18-1166 ① ⑦	18-1155 ①	N/D	18-1158
V-200XRI (EFI)	D082000 & Sup	18-1143	18-1117	18-1115 ⑤ ①	18-1166 ① ⑦	18-1155 ①	N/D	18-1158
V-220	B117316 & Sup	18-1143	18-1117	18-1122 ⑤	18-1166	18-1155	N/D	18-1158
V-225	5628028 & Sup	18-1164	—	18-1122 ⑤	18-1166	18-1155	N/D	18-1158
225	D280813 & Sup	18-1143	18-1117	18-1157 ①	18-1159 ①	18-1155 ①	N/D	18-1158
XR-4 ③	B242885 & Sup	18-1143	—	18-1157	18-1156	N/D	N/D	18-1158
XR-4	B242885 & Sup	18-1143	—	18-1157	18-1156	N/D	N/D	18-1158
XR-4 ③	C100861 & Sup	18-1143	—	18-1157	18-1156	N/D	N/D	18-1158
XR-4 ④	C100861 & Sup	18-1143	—	18-1157	18-1156	N/D	N/D	18-1158
XR-4	C239553 & Sup	18-1143	—	18-1157	18-1156	N/D	N/D	18-1158
XR-6	D082000 & Sup	18-1143	—	18-1157	18-1156	N/D	N/D	18-1158

① Sólo rotación standar.

③ Para unidades con número 1655-9572C.

④ Para unidades con número 1674-814247C.

⑤ Necesita dos cojinetes.

⑥ Para 5/8 cojinete doble.

⑦ Use 18-1155 para aplicaciones contra-rotación.

⑧ Usar piñón 43-19672.



18-2244

18-22441-9①

(Env. de 50 Sin junta)

TAPÓN DRENAJE

• 3/8" -16 hilo

Reemplaza: 10-20259, 10-28634, 10-28634A1, 10-79953A2, 10-79953Q2, 10-79953, 10-79953Q04, 816610A1, 816610A2, F40109, 10-F50109
Incluye juntas 18-2945

② **18-2375D**



18-2375

18-23751-9①

(Env. de 50 sin junta)

TAPÓN DRENAJE

• 3/8" -16 hilo

Reemplaza: 10-14834, 10-14834A1, 22-67892, 22-67892A1, 22-67892A05, 22-67892A06, 28-8M0058389
Incluye junta 18-2945



18-2155

CASQUILLO CAMBIO

Reemplaza: 23-37428A1, 23-55419A1, 23-77631A2
35-200 HP

① Precio por envase

② Referencias acabadas en D envasadas



18-3719
TUERCA PIÑÓN
 Reemplaza: 11-35921, 11-47411,
 11-826375, 11-F694188
 hilo 5/8" - 18 • Llave 1 1/16"

18-2359
JUEGO TUERCAS
EJE TRANSMISIÓN

— INCLUYE —

Sierra #	Descripción	Reemplaza:
18-3719	Tuerca piñón	11-35921
18-2343	Tuerca piñón arand.	12-92721
18-2343-9	Tuerca piñón arandela	12-92721

② Precio por envase

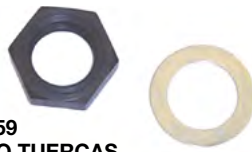

18-1736
EJE
 Reemplaza: 45-43031A1
 Para: 100 4 cil (1988 & Sup), 115 4 cil (1989 & Sup),
 125 4 cil (1994 & Sup)



18-1737
EJE (32 1/4" largo)
 Reemplaza: 45-440001
 Para: V-115 DFI 2.5L (2000), V-135 (1986 & Sup), V-135 DFI 2.5L (1998 & Sup), V-150 (1978 & Sup), V-150 EFI (1996-01), V-150 Mag/EFI (1993-95), V-150 DFI 2.5L (1998 & Sup), V-150 Mag (1980-85), V-175 (1976-99), V-175 EFI (1996 & Sup), V-175 Mag/EFI (1991-95), V-175 DFI 2.5L (2001 & Sup), V-175 XRI EFI (1991-95), V-200 (1978 & Sup), V-200 EFI (1989-01), V-200 Mag/EFI (1992-95), V-200 EFI 2.5L (2002 & Sup), V-200 XRI/EFI (1991-95), XR-4 (1988-91), XR-6 (1992 & Sup)



18-2254
EJE TRANSMISIÓN
 Reemplaza: 44-850308



18-2239
EJE TRANSMISIÓN
 Reemplaza: 44-94148



18-2260
EJE TRANSMISIÓN
 Reemplaza: 44-17915, 44-98418



18-2236
SELECTOR CAMBIO
 Reemplaza: 52-12777, 52-34239, 52-814756,
 52-822539, 52-822539T



18-1550
KIT COMPLETO ENGRANAJES
 Reemplaza: 43-850036T,
 43-881260A3, 52-850048T
 Avante, Piñón, Reverso y selector para 4 cil.: Para: 100 4 cil con 6 dientes desplazable
 reverso(1988-98), 115 4 cil con 6 dientes desplazable reverso (1989-98), 125 4 cil con 6
 dientes desplazable reverso(1994-98) (2.07:1 Ratio)



18-1551
KIT COMPLETO DE ENGRANAJES
 Reemplaza: 43-803615T2,
 52-859340T, 43-828175A1
 Avante, Piñón, Reverso y selector de V-6:
 Para: V-150 (XR6, Mag III)(1997 & Sup), V-150 EFI (1997 & Sup), V150 DFI
 (1998 & Sup), V-175 (1997 & Sup), V-175 EFI (1997 & Sup), V-175 DFI
 (2001 & Sup), V-200 (1997 & Sup), V-200EFI 2.5L (1997 & Sup) (1.87:1 Ratio)



18-1560
REVERSO ENGRANAJE
 Reemplaza: 43-850036T, 43-850036
 Para: 75 4-tiempos (2000-02), 90 4-tiempos (2000-02), 100 4 cil con 6 JAW Rev
 depl. (1988 & Sup), 115 4 cil con 6 dientes Rev depl. (1989 & Sup), 115 4-tiempos
 EFI (2001 & Sup), 125 4 cil con 6 dientes Rev despl. (1994 & Sup) (2.07:1 Ratio)



18-1564
KIT ENGRANAJE
 Reemplaza: 43-803615T2, 43-803615T1
 Para: V-150 (1978 & Sup), V-150 EFI (1996-01), V-150 DFI 2.5L (1998 & Sup),
 V-150 EFI 2.5L (2002 & Sup), V-175 EFI (1996-01), V-175 DFI 2.5L (2001 &
 Sup), V-175 EFI 2.5L (2002-03), V-200 (1978 & Sup), V-200 EFI (1989-01),
 V-200 EFI 2.5L (2002 & Sup) (1.87:1 Ratio)

**18-1565
SELECTOR**

Reemplaza: 52-859340T

Para: V-115 DFI 2.5L (2000), V-135 (1986 & Sup), V-135 DFI 2.5L (1998 & Sup), V-150 (1978 & Sup), V-150 EFI (1996-01), V-150 Mag/EFI (1993-95), V-150 DFI 2.5L (1998 & Sup), V-150 Mag (1980-85), V-175 (1976-99), V-175 EFI (1996 & Sup), V-175 Mag/EFI (1991-95), V-175



**18-1566
ENGRANAJE REVERSO**

Reemplaza: 43-828175A1

Para: V-150 (1978 & Sup), V-150 EFI (1996-01), V-150 DFI 2.5L (1998 & Sup), V-175 (1976-99), V-175 EFI (1996-01), V-175 DFI 2.5L (2001 & Sup), V-200 (1978 & Sup), V-200 EFI (1989-01), V-200 EFI 2.5L (2002 & Sup), XR-6 (1992-99) (1.87:1 Ratio)



**18-4830
CARCASA COLA**

Reemplaza: 1667-9011G59

Para: 100 4cil (1988-99), 115 4cil (1989 & Sup), 115 3cil DFI (2004 & Sup), 115 EFI 4-Tiempos(2001 & Sup), 125 4cil (1994 & Sup), 30 4-tiempos (1999-01), 30 Carb 3cil 4-tiempos (2002 & Sup), 40 4-tiempos (1998-01), 40 4-tiempos 4cil (2001-02), 40 Carb 3cil 4-tiempo (2002 & Sup), 40 EFI 4cil 4-tiempos (2002 & Sup), 40 Jet (2001 & Sup), 45 Jet (1994-98), 50 4-tiempos (1995-00), 50 4cil 4-tiempos (2001-02), 50 Bigfoot 4-tiempos(1995-00), 50 EFI 4cil 4-tiempos (2002 & Sup), 55 3cil (1996 & Sup), 60 3cil (1984 & Sup), 60 3cil Bigfoot (1998), 60 4cil 4-tiempos (2001-02), 60 EFI 4cil 4-tiempos (2002 & Sup), 65 Jet (1994 & Sup), 75 3cil (1987 & Sup), 75 4-tiempos (2000 & Sup), 75 3cil 1.5L DFI (1995 & Sup), 80 Jet (1994 & Sup), 90 3cil (1987 & Sup), 90 4-tiempos (2000 & Sup), 90 3cil 1.5L DFI (2004 & Sup) con 6 dientes (Design II)



**18-4832
CARCASA COLA**

Reemplaza: 1647-9148T93. PARA:140 JET(TODOS), MAGNUM III (1992-99), V-115 DFI 2.5L (2000) V-135 (1986-SUP), V-135 DFI 2.5L (1998-SUP), V-150 (1978-SUP),V-150 EFI (1996-01),V-150 DFI 2.5L (1998-SUP), V-175 (1976-99), V-175 DFI 2.5L (2001-SUP), V-200(1978-SUP), V-200 EFI 2.5L (2002-SUP), XR6 (1992-SUP)



**18-4850
COLA COMPLETA**

Reemplaza: 1667-9011G77, 1667-9011G78, 1667-9011G10, 1667-9011G11, 1667-9011G51, 1667-9011J6, 1667-9011R6
Para: 100/115/125 4-cil con 6 dientes (Design II) (2.07:1 Ratio)



**18-4851
COLA COMPLETA**

Reemplaza: 1647-6693A3, 1647-7350A5, 1647-7350A26, 1647-8688A1, 1647-9148A69, 1647-9148A8, 1647-9148A84, 1647-9148T84, 1647-9148R84
Para: 135/150/200/225 V6 (1.87:1 Ratio)



APLICACIONES FUERABORDA MERCURY UNIDAD INFERIOR

Modelo	Número de serie	Eje transmisión	Tuerca piñón	Eje hélice	Selector
40 4 tiempos - BigFoot	0T178500 - 1B226999		18-3719	18-2254	18-1562
50 4 tiempos - BigFoot	0G231123 - 1B226999		18-3719	18-2254	18-1562
60 Sea Pro/Marathon/BigFoot	0G590000 & Sup		18-3719	18-2254	18-1562 ④
60 Four Stroke - BigFoot	0T178500 - 1B226999		18-3719	18-2254	18-1562
650 (4 cil.)	1542745 - 1765403	N.L.A.	—	—	18-2236
650 (4 cil.)	2119749 - 2309310	—	—	—	18-2236
650 (4 cil.)	2309311 - 2452709	—	18-3719	—	18-2236
650 (4 cil.)	2503991 - 2803561	—	18-3719	—	18-2236
650 (4 cil.)	2803562 - 2874263	—	18-3719	—	18-2236
650 (4 cil.)	2997339 & Sup	—	18-3719	—	18-2236
70 (3 cil.)	A996142 - & Sup	—	18-3719	—	18-2236 ⑤
70 (3 cil.)	A996142 - & Sup	—	18-3719	18-2254	18-1562
75 (4 cil.)	6432901 & Sup	—	18-3719	—	18-2236
75 (3 cil.)	A996142 - & Sup	—	18-3719	—	18-2236 ⑤
75 (3 cil.)	A996142 - 0G760299	—	18-3719	18-2254	18-1562
75 (3 cil.)	0G760300 & Sup	—	18-3719	18-2254	18-1562
75 DFI	0T980000 & Sup	—	18-3719	18-2254	18-1562
75 4 tiempos	0G960500 - 0T800999	—	18-3719	18-2254	18-1562
800 (4 cil.)	2559001 - 3144218	—	18-3719	—	18-2236
800 (4 cil.)	3144219 - 3493912	—	18-3719	—	18-2236
80 (4 cil.)	4831999 - 6432900	—	18-3719	—	18-2236
80 (3 cil.)	A996142 & Sup	—	18-3719	—	18-2236 ⑤
80 (3 cil.)	A996142 & Sup	—	18-3719	18-2254	18-1562 ④
850 (4 cil.)	3493913 - 4831998	—	18-3719	—	18-2236
900 (6 cil.)	1766824 - 1869775	N.L.A.	—	—	18-2236
900/90 (6 cil.)	4845301 - & Sup	—	18-3719	—	18-2236
90 (3 cil.)	A996142 - 0G760299	—	18-3719	—	18-2236 ⑤
90 (3 cil.)	A996142 - 0G760299	—	18-3719	18-2254	18-1562 ④
90 (3 cil.)	0G760300 & Sup	—	18-3719	18-2254	18-1562
90 DFI	0T801000 & Sup	—	18-3719	18-2254	18-1562
90 4 tiempos	0G960500 - 0T800999	—	18-3719	18-2254	18-1562

① Solo eje largo

② Solo rotación standard

③ Solo offshore

④ 6d. selector reverso

⑤ 3 d. Selector rev

⑥ Pasador, sin tuerca eje

transm.

N.D No disponible

APLICACIONES CONTINUAN EN LA SIGUIENTE PÁGINA

APLICACIONES FUERABORDA MERCURY UNIDAD INFERIOR

Modelo	Número de serie	Eje transmisión	Tuerca piñon	Eje hélice	Acople
100 (4 cil.)	B209468 - 0G760299	—	18-3719	—	18-2236 ⑤
100 (4 cil.)	B209468 - 0G760299	—	18-3719	18-2254	18-1562 ④
100 (4 cil.)	0G760300 & Sup	—	18-3719	18-2254	18-1562
1150	2836019 - 2933900	—	18-3719	—	18-2236
1150	2933901 - 3525440	—	18-3719	—	18-2236
1150	3525441 - 4112634	—	18-3719	—	18-2236
1150	4112635 - 4855152	—	18-3719	—	18-2236
1150 / 115	4855153 - 5314655	—	18-3719	—	18-2236
115 (6 cil.)	5314656 - 5600966	—	18-3719	—	18-2236
115 (6 cil.)	5600967 - 6436122	—	18-3719	—	18-2236
115 (6 cil.)	6436123 & Sup	—	18-3719	—	18-2236
115 (4 cil.)	C100000 - 0G760299	—	18-3719	—	18-2236 ⑤
115 (4 cil.)	C100000 - 0G760299	—	18-3719	18-2254	18-1562 ④
115 (4 cil.)	0G760300 & Sup	—	18-3719	18-2254	18-1562
115 DFI	0T801000 & Sup	—	18-3719	18-2254	18-1562
115 4 tiempos	0T178500 - 0T800999	—	18-3719	18-2254	18-1562
1250	2314956 - 2839368	—	18-3719	—	18-2236
125 (4 cil.)	0D283222 - 0G760299	—	18-3719	—	18-2236 ⑤
125 (4 cil.)	0D283222 - 0G760299	—	18-3719	18-2254	18-1562 ④
125 (4 cil.)	0G760300 & Sup	—	18-3719	18-2254	18-1562
1350	2839369 - 2940020	—	18-3719	—	18-2236
1350	2940021 - 3293233	—	18-3719	—	18-2236
1400	3293234 - 3502805	—	18-3719	—	18-2236
140	4865687 & Sup	—	18-3719	—	18-2236
1500	3502806 - 4121434	—	18-3719	—	18-2236
1500	4121435 - 4865677	—	18-3719	—	18-2236
V-135	0A904646 - 0G437999	18-1737	18-3719	18-2239	—
V-135	0G438000 - 0T178499	18-1737	18-3719	18-2239 ②	—
V135 DFI	G590000 - 1B417701	18-1737	18-3719	18-2239	18-1565
V140	T178500 & Sup	—	18-3719	18-2239	—
V-150 (Casting # 1647-6670C)	4868998 - 0A904645	—	18-3719	—	—
V-150 (Casting #1647-8675C)	4868998 - 0A904645	—	18-3719	18-2239	—
V-150	4868998 - 0A904645	18-1737	18-3719	18-2239	—
V-150	0A904646 - 0G437999	18-1737	18-3719	18-2239	—
V-150	0G438000 & Sup	18-1737	18-3719	18-2239	18-1565
V-150 XR-4 (Casting #1655-9572C)	B242885 - 0D081999	—	18-3719	—	18-2236
V-150 XR-4 (Casting #1674-814247C)	B242885 - 0D081999	—	18-3719	—	18-2236
V-150 XR-6	D082000 - 0G303045	18-1737	18-3719	18-2239	18-2236
V-150 XR-6	0G438000 & Sup	18-1737	18-3719	18-2239	18-1565
V-150XRI (EFI)	D082000-0G437999	18-1737	18-3719	— ②	18-2236 ②
V-150XRI (EFI)	0G438000 & Sup	18-1737	18-3719	18-2239 ②	18-1565
V150 DFI	G590000 & Sup	18-1737	18-3719	18-2239	—
V-175	4301235 - 5393736	— ⑥	18-3719	—	—
V-175	5393737 - 6618750	— ⑥	18-3719	18-2239	—
V-175	6618751 - 0G437999	18-1737	18-3719	18-2239	—
V-175	0G438000 & Sup	18-1737	18-3719	18-2239	18-1565
V-175XRI (EFI)	D000750 - 0G437999	18-1737	18-3719	18-2239	—
V-175XRI (EFI)	0G438000 & Sup	18-1737	18-3719	18-2239	18-1565
V-200	4839034 - 6625220	— ⑥	18-3719	18-2239	—
V-200	6625221 - 0G437999	18-1737	18-3719	18-2239	—
V-200	0G438000 & Sup	18-1737	18-3719	18-2239	18-1565
V-200 (EFI)	C100861 - 0G437999	18-1737	18-3719	18-2239	—
V-200 (EFI)	0G438000 & Sup	18-1737	18-3719	18-2239	18-1565
V-200 (2.5L)	C291520 - D081999	—	18-3719	18-2239 ②	—
V-200 DFI	0G438000 & Sup	—	18-3719	—	18-1565
V-220	B117316 & Sup	—	18-3719	18-2239	—
V-225	5628028 & Sup	— ①	18-3719	18-2239	—
225	D280813 & Sup	—	18-3719	—	—
MODELOS ALTAS PRESTACIONES					
2.4 EFI	B290010 & Sup	—	18-3719	18-2260 ② ③	—
XR-2	B290314 - C276429	—	18-3719	18-2260 ②	—
MOD-VP	B290066 - C276379	—	18-3719	18-2260	—

- ① Solo eje largo ③ Solo offshore ⑤ Acople 3 d reverso transm.
 ② Solo rotación standard ④ Acople 6d. reverso ⑥ Pasador, sin tuerca eje N.D No disponible

<p>Env. de 10</p>  <p>18-0202-9③ MUELLE Reemplaza: 8227731 Para: Mercury/Mariner 25-125hp Fueraborda</p>	 <p>18-3751 TUERCA CIERRE Reemplaza: 79448 Para: V-6</p>	 <p>18-2298 ARANDELA CIERRE Reemplaza: 14-18323, 14-17460</p>																				
 <p>18-2299 ARANDELA CIERRE Reemplaza: 14-79447, 14-52833</p>	 <p>TUERCAS DE ACERO INOX</p>	<table border="1"> <thead> <tr> <th>Ref #</th> <th>O.E. #</th> <th>Medida rosca</th> <th>Cant. env.</th> </tr> </thead> <tbody> <tr> <td>18-3720 ⑦</td> <td>11-34932</td> <td>3/8" - 24</td> <td>1</td> </tr> <tr> <td>18-3721 ⑦</td> <td>11-34933, 11-95702 11-82671015, 11-46355 11-33962, 11-29241, 11-24648, 11-22178, 11-21298</td> <td>7/16" - 20</td> <td>6</td> </tr> <tr> <td>18-3722 ⑦</td> <td>11-35888, 11-20361, 11-8267089</td> <td>1/4" - 28</td> <td>5</td> </tr> <tr> <td>18-3723 ⑦</td> <td>11-45592</td> <td>5/16" - 24</td> <td>1</td> </tr> </tbody> </table>	Ref #	O.E. #	Medida rosca	Cant. env.	18-3720 ⑦	11-34932	3/8" - 24	1	18-3721 ⑦	11-34933, 11-95702 11-82671015, 11-46355 11-33962, 11-29241, 11-24648, 11-22178, 11-21298	7/16" - 20	6	18-3722 ⑦	11-35888, 11-20361, 11-8267089	1/4" - 28	5	18-3723 ⑦	11-45592	5/16" - 24	1
Ref #	O.E. #	Medida rosca	Cant. env.																			
18-3720 ⑦	11-34932	3/8" - 24	1																			
18-3721 ⑦	11-34933, 11-95702 11-82671015, 11-46355 11-33962, 11-29241, 11-24648, 11-22178, 11-21298	7/16" - 20	6																			
18-3722 ⑦	11-35888, 11-20361, 11-8267089	1/4" - 28	5																			
18-3723 ⑦	11-45592	5/16" - 24	1																			

⑦ Precio por pieza. Para pedir envasado añade -9 a la referencia.

③ Precio por envasado

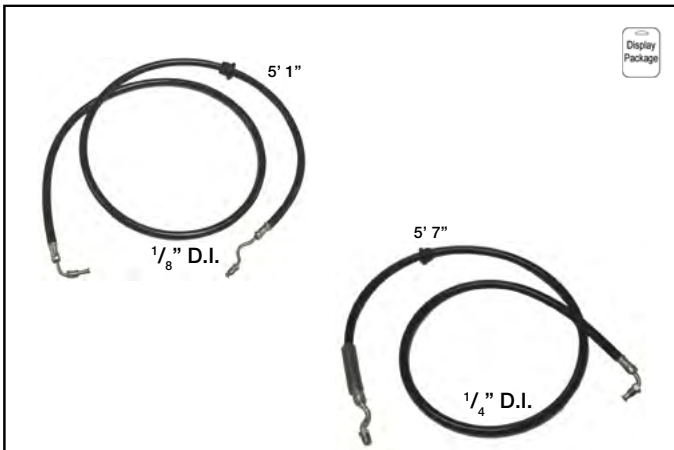

MANGUERA POWER TRIM

Para los equipados con power trim, motores en línea excepto aquellos con bomba power trim montada entre soportes de abrazaderas del motor.

Ref #	Reemplaza:	Descripción
18-2110	32-45327, 32-88005, 32-97153A1	Diámetro pequeño 2 por motor
18-2111	32-88006, 32-45959, 32-97154A1	Diámetro grande 2 por motor

18-3701D Display Package

**18-3701
KIT TUERCA HÉLICE**
Reemplaza: 11-52707A1, 11-52707A2, 11-52707Q1

— CONTIENE —

Ref #	O.E. #	Descripción
18-3200 (2)	14-31210, 14-816629	Aran.bloqueo
18-3700	11-52707	Tuerca hélice

18-3702D Display Package

**18-3702
KIT TUERCA HÉLICE**
Reemplaza: 11-69578A1, T1, Q1

— CONTIENE —

Ref #	O.E. #	Description
18-3204 (2)	14-76281	Aran.bloqueo
18-3704	11-69578	Tuerca hélice

PACK. DE 10

**18-3200
18-3200-9^②
ARANDELA BLOQUEO**
Reemplaza: 14-31210, 14-816629, 14-816629Q, 14-F697140

PACK. DE 10

**18-3204
18-3204-9^②
ARANDELA BLOQUEO**
Reemplaza: 14-76281

**18-3700
TUERCA HÉLICE**
Reemplaza: 11-52707, 11-52707A1, 11-52707Q1, 11-52707A2, 11-827614 F7040

**18-3704
TUERCA HÉLICE**
Reemplaza: 11-69578

**18-3703
TUERCA HÉLICE**
Reemplaza: 11-88228
Para: 9.9-25 HP 1986-Sup

**18-3714
ARANDELA DE BRONCE**
Reemplaza: 12-31211A2, 12-31211, 12-31211A3, 12-31211 Q03
Para: 135-275 HP (V6 2 ciclos)

APLICACIÓN ARANDELA BLOQUEO/TUERCA HÉLICE / KIT TUERCA

HP	Desde	Hasta	Arandela Bloqueo	Tuerca Hélice	Kit tuerca Hélice	HP	Desde	Hasta	Arandela bloqueo	tuerca Hélice	Kit tuerca Hélice
9.9	G760300	& SUP	—	18-3703	—	80	2559001	& SUP	18-3200	18-3700	18-3701
15	G590000	& SUP	—	18-3703	—	85	1460999	3493912	18-3200	—	—
18	5837437	& SUP	—	18-3703	—	85	3493913	4831998	18-3200	18-3700	18-3701
20	6443973	& SUP	—	18-3703	—	90	1766824	4845300	18-3200	—	—
25	6416713	& SUP	—	18-3703	—	90	4845301	& SUP	18-3200	18-3700	18-3701
35	—	③	18-3204	18-3704	18-3702	95	1869776	2318585	18-3200	—	—
40	—	③	18-3204	18-3704	18-3702	100	1464949	2484632	18-3200	—	—
50	—	③	18-3204	18-3704	18-3702	100	2484633	2836018	18-3200	18-3700	18-3701
60	—	③	18-3204	18-3704	18-3702	100	B209468	& SUP	18-3200	18-3700	18-3701
65	1542745	2503990	18-3200	—	—	110	1870204	2314955	18-3200	—	—
65	2503991	3293183	18-3200	18-3700	18-3701	115	2836019	& SUP	18-3200	18-3700	18-3701
70	1482212	1566239	18-3200	—	—	125	2314956	2536209	18-3200	—	—
70	—	③	A996141	18-3204	18-3704	125	2536210	2839368	18-3200	18-3700	18-3701
70	A996142	& SUP	18-3200	18-3700	18-3701	135	2839369	3293233	18-3200	18-3700	18-3701
75	6432901	& SUP	18-3200	18-3700	18-3701	140	3293234	& SUP	18-3200	18-3700	18-3701
80	1405637	1566239	18-3200	—	—	150(En línea)	3502806	& SUP	18-3200	18-3700	18-3701
③ Para mayoría de aplicaciones ④ 4-Tiempos Bigfoot						V-6	TODOS	—	18-3200	18-3700	18-3701

**18-4444
LLAVE HÉLICE**
Reemplaza: 91-95830A1, 91-95830, 91-38277A1

**18-4446
LLAVE HÉLICE Y KIT TUERCAS**
— CONTIENE —

Ref #	Descripción	O.E. #	Cant.
18-3200	Arandela	14-31210, 14-816629	2
18-3700	Tuerca hélice	11-52707	1
18-4444	Llave hélice	91-95830A1	1

**18-4459
LLAVE HÉLICE**
Reemplaza: 91-821887A1, 91-859046Q4, 91-859046T4

① Referencias acabadas en "D" envasadas
② Precio por Pack

18-9075
ESPACIADOR
Reemplaza: 23-888690
Para: 2-tiempos: 115hp. - 300hp. (1993-Actual)
4-tiempos: 115hp. - 225hp. (2002-Actual)



18-9076
COLLAR
Reemplaza: 23-888690-1
Para: 2-tiempos: 115hp. - 300hp. (1993-actual)
4-tiempos: 115hp. - 225hp. (2002-actual)



18-9077
ARANDELA
Reemplaza: 13-888363-2
Para: 2-tiempos: 115hp. - 300hp. (1993-actual) 4-tiempos: 115hp. - 225hp. (2002-actual)



18-9078
ARANDELA ACERO INOXIDABLE
Reemplaza: 12-855682-2
Para: 2-tiempos: 115hp. - 300hp. (1993-Actual)
4-tiempos: 115hp. - 225hp. (2002-Actual)



18-9079
KIT ARANDELAS
Reemplaza:
Para: Yamaha 2-tiempos 115-300hp (1993 & Sup); Yamaha 4-tiempos 115-225hp (2002 & Sup); Mercury 4-tiempos 225 EFI S/N OT653945 & Sup



① **18-4220D**



Display Package

ARANDELA

Ref #	Reemplaza
18-4220	12-13171, 12-77987, 12-8354671, 12-77987A1, 12-835467, 12-835467Q01
	V-6 fueraborda & Colas Mercurier
18-4221	13191A1, 75282A1
	4 & 6 En línea - 75-150 HP

18-4233
ARANDELA
Reemplaza: 73345, 73345A1, 12-92647M
35-70 HP



18-9010
TOMA DE AGUA
Reforzada



Display Package

18-3607
SOPORTE
Reemplaza: 893409
Para: 200/225 4_tiempos Verado (S/N OT980000 & Sup), 250/275 4-tiempos Verado (S/N OT801000 & Sup)



18-79989
ARRASTRE STICKS
Para: Para mayoría de fuerabordas hasta 150 hp con tilt/trim integral.

ZINC es para aplicaciones en agua salada.
MAGNESIO es para aplicaciones en agua dulce.
ALUMINIO es para aplicaciones en agua dulce y salada.

603158 Al.
18-6156M Mag.
KIT ANODOS
Verados 4 cil. Todos los modelos



603159 Al.
18-6157M Mag.
KIT ANODOS
Reemplaza: 8M0058677
Verado 6 cil. Todos los modelos



① **18-6011 Alu.**
② **18-6241M Mag.**
③ **009354 Zinc**
ANODOS
Reemplaza:
31640, 31640A1, 97-31640Q4, 97-31640B4, 31640A4, 31640A2, 316404, 316403, 72436A1
Use en línea 3, 4 & 6 Cil, V6



① **18-6014A Alu.**
③ **025849**
ANODOS
Reemplaza:
46399A1, 822777A1, 822777Q1, 822777A4, 822777A3, 8227772, 822777, 463999A2
Para uso con 225 (3.0L Carb.) modelos



① **603046 Alu.**
② **18-6244 Mag.**
③ **009371 Zinc**
ANODOS
Reemplaza:
76214, 97-76214Q5, 97-762145, 76214A5, 786214A2, 762142, 762142A1
200, 225, 250HP, V-155-V-200, & Todos Bravos



① **603048 Alu.**
③ **009464 Zinc**
ANODOS
Reemplaza: 826134, 826134A1, 97-826134Q

① Aluminio ② Magnesio ③ Zinc
④ Envase de 10 unidades ⑤ Envase de 10 unidades



③ 025848 Zinc
① 603049 Al.
ANODO PLACA MONTAJE
Reemplaza: 43396A2, 818298A1, Q1
Para uso en soporte de transm: 175HP/150EFI/200EFI (S/N OG303046 & Sup)

① 18-6245D Display Package



18-6245 TORNILLO MONTAJE ÁNODO
Reemplaza: 10-32470
Para uso con: 18-6011, 18-6014, 18-6016
 $\frac{7}{16}$ " X $1\frac{3}{4}$ " Allen H



18-2599 RETEN/HERRAMIENTA
Reemplaza: 26-816575A2



18-2742 MANGUITO FUELLE
Reemplaza: 85552



009353 ANODO ZINC
Para motores **Mercuriser 80/140hp.** Aleta larga. Rosca 7/16".
Reemplaza: 34127A1.



009370 ANODO ZINC
Para motores fueraborda **Mercury 25/75hp.** y **Mercuriser 90/190/80/115hp.** Reemplaza: 43396.

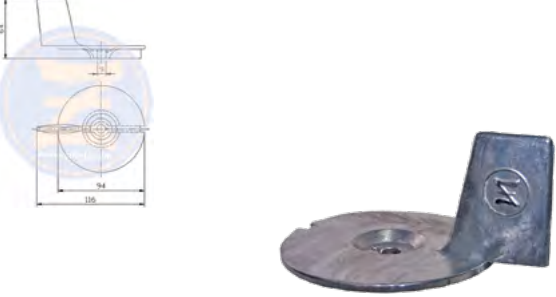

025299 ANODO ZINC
Para motores **Mercury de 20/25hp.**
Reemplaza: 94286.



025850 ANODO ZINC
Para motores de 25hp. Posterior 1990.
Reemplaza: 98432.



025849 ANODO ZINC
Para motores **Mercury Alpha One 120/140/470/485R/MR.** Hélice inoxidable. Rosca 7/16".
Reemplaza: 46399A1.



025301 ANODO ZINC
Para motores fueraborda **Mercury 20hp.** Rosca 5/16".
Reemplaza: 47820A1.



025839
ANODO ZINC
 Para motores Mercury BF75/90/115/130/135/150/200/225hp.
 Reemplaza: 41109-ZW1-003

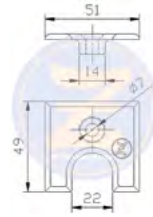

025846
ANODO ZINC
 Para motores Mercury-Mercruiser de 4,5/7hp.
 Reemplaza: 9411

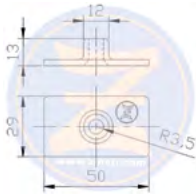

025390
ANODO ZINC
 Placa para fueraborda Mercury/Mercruiser 4,5-7,5-9,8 hp.
 hasta 1.987. Reemplaza: 85824



603200
ANODO ALUMINIO
 Para 25Hp hasta 50Hp. Incluye tornillo
 Reemplaza: 822157TZ

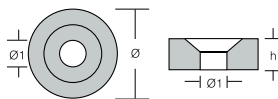

ANODO tipo arandela.
 009462 Zinc (603203 Alu.) Ø:20 - Ø1:7,0 - h:7
 009358 Ø:24 - Ø1:6,5 - h:6,5

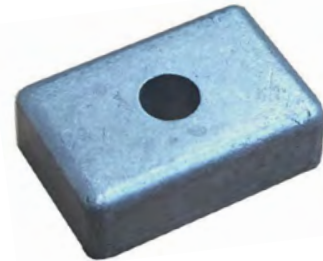

603201
ANODO ALUMINIO
 Para 4Hp hasta 20Hp.
 Reemplaza: 875208

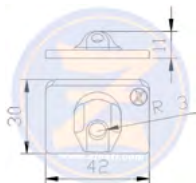

025847
ANODO ZINC
 Para motores Mercury-Mercruiser de 6/8/9,9hp. y Mariner 9,9hp.
 Reemplaza: 42121.

603202
ANODO ALUMINIO
 Para 25Hp hasta 50Hp.
 Reemplaza: 8252711

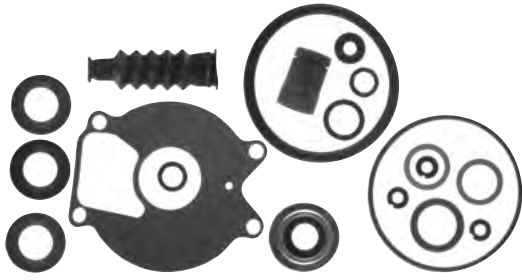

18-2624
KIT RETENES PARTE INFERIOR
Reemplaza: 26-85090A2

— CONTIENE —

Ref #	Descripción	O.E.#	Cant.
18-0579	Retén	26-41131	1
18-0580	Retén	26-41132	1
18-0586	Retén	26-99325	2
18-7419	Aro	25-69202	1
18-2562	Junta	27-99326-1	1
18-2945	Arandela	12-20260	2
18-2742	Manguito fuelle	85552	1
18-2560	Arandela	12-86645	2
18-7135	Aro	25-35276	1
18-7188	Aro	25-805726	2
18-7956	Aro	25-85549	1
18-7100	Aro	25-85594	1

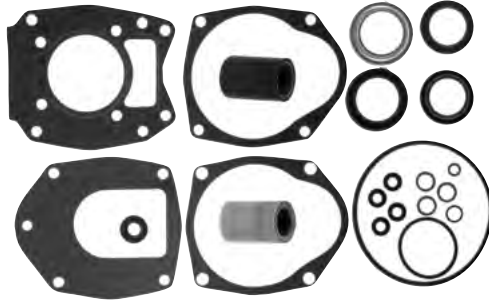

18-2626
KIT RETENES PARTE INFERIOR
Reemplaza: 26-43035A4, 26-43034A1, 26-43034A2, 26-43034A3

— CONTIENE —

Ref #	Descripción	O.E.#	Cant.
18-0522	Retén	26-43036	1
18-0583	Retén	26-43035	1
18-2002	Retén	26-30550, 26-76868	1
18-2053	Retén	26-70081	1
18-2054	Retén	26-8164641	1
18-2563	Junta platina a tapa Bomba de agua	27-43034-1	1
18-2564	Junta base bomba agua a platina	27-43033-1	1
18-2565	Junta aloj. engranaje a base bomba de agua	27-43047-2	1
18-2566	Junta platina a tapa bomba de agua	27-817277	1
18-2945	Arandela	12-19183	3
18-4261	Arandela	19643	1
18-7188	Aro	25-805726	1
18-7198	Aro	25-45710	1

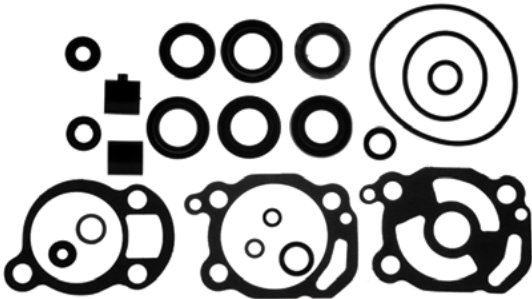

18-2627
KIT RETENES PARTE INFERIOR
Reemplaza: 26-66303A1

— CONTIENE —

Ref #	Descripción	O.E.#	Cant.
18-0595	Retén	26-66303	2
18-2004	Retén, Base bomba de agua	26-20070	2
18-2006	Retén, Base bomba de agua	26-897154	1
18-2019	Retén	26-26805	1
18-2827	Junta platina superior a bomba de agua	27-39623	1
18-2828	Junta base bomba inferior	27-39625	1
18-2945	Arandela	12-20260	1
18-4261	Arandela	12-20262	1
18-7120	Aro	25-38933	1
18-7163	Aro	25-33465	1
18-7164	Aro	25-33466	1
18-7180	Aro	25-26802	2

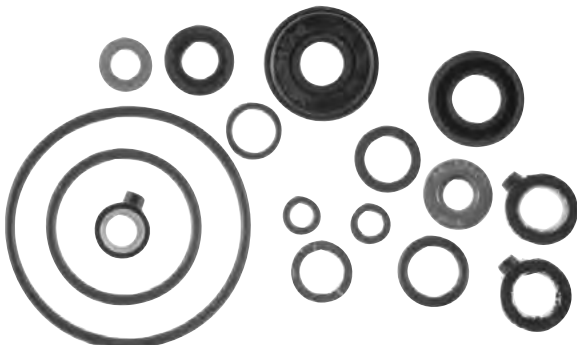

18-2628
KIT RETENES PARTE INFERIOR
Reemplaza: 26-77066A1

— CONTIENE —

Ref #	Descripción	O.E.#	Cant.
18-0584	Retén aceite, eje hélice	26-66022	1
18-2010	Retén, base bomba de agua	26-897153	1
18-2945	Arandela	12-20260	1
18-4261	Arandela	12-20262	1
18-7116	Aro	25-62704	1
18-7120	Aro	25-38933	1
18-7156	Aro	25-29439	1
18-7168	Aro	25-48171	1
18-7171	Aro	25-30529	1
18-7180	Aro	25-26802	1
18-8308	Retén, eje cambio	26-30696	1
18-8310	Retén, base bomba de agua	26-30900T	1

— CONTIENE —

Ref #	Descripción	O.E.#	Cant.
18-2006	Retén	26-897154	2
18-2560	Arandela	12-86645	2
18-2562	Junta alojamiento engr. a platina	27-99326-1	1
18-2742	Junta	85552	1
18-2945	Arandela	12-20260	2
18-7135	Aro	25-35276	1
18-7419	Aro	25-69202	1
18-7956	Aro	25-85549	1
18-7100	Aro	25-85594	1
18-8348	Aro	25-86203	1



18-2629
KITS RETENES PARTE INFERIOR
Reemplaza: 26-85090A1

— CONTIENE —

Ref #	Descripción	O.E.#	Cant.
18-0500	Retén	26-817472	1
18-0622	Junta, platina inferior	27-19701	1
18-2051	Retén	26-69188	1
18-2052	Retén	26-69189	1
18-2945	Arandela	12-19183	3
18-7168	Aro	25-48171	2
18-7173	Aro	25-30224	1
18-7950	Aro	25-45258	1



18-2635
KIT RETENES PARTE INFERIOR
Reemplaza: 26-814669A2

— CONTIENE —

Ref #	Descripción	O.E.#	Cant.
18-2563	Junta platina a bomba de agua	27-43034-1	1
18-2564	Junta base bomba de agua a platina	22-43033-1	1
18-2945	Junta tornillo a drenaje	12-19183,12-20260	2
18-2599	Retén y herramienta	26-816575A2	1
18-2014	Retén	26-89238	1
18-2013	Retén	26-16977	1
18-2054	Retén	26-8164641	1
18-7159	Retén	25-31534	1
18-7176	Retén	25-90011	1
18-7420	Retén	25-21836	2
18-7440-1	Retén	25-36318	2



18-2642
KIT RETENES PARTE INFERIOR
Reemplaza: 26-816575A5

— CONTIENE —

Ref #	Descripción	O.E.#	Cant.
18-2599	Retén y herramienta	26-818575A2	1
18-2564	Junta base bomba de agua a platina	27-43033-1	1
18-2566	Junta platina a tapa bomba de agua	27-817277	1
18-2945	Arandela	12-19183	1
18-2944	Retén	26-45577	1
18-2002	Retén	26-30550, 26-76868	1
18-2009	Retén	26-892361	1
18-2013	Retén	26-16977	1
18-2014	Retén	26-89238	1
18-2056	Retén	26-965031	2
18-2076	Retén	26-12224	1
18-2077	Retén	26-14077	1
18-7159	Aro	25-31534	1
18-7168	Aro	25-48171	2
18-7176	Aro	25-90011	1
18-7420	Aro	25-21836	2
18-7440-1	Aro	25-36318	2
18-2056	Aro	26-66302	2
18-7413	Aro	25-62702	2
18-2009	Retén	26-892361	1
18-2430	Junta tornillo drenaje	26-830749	1



18-2646-1
KIT RETENES CAJA DE ENGRANAJES
Reemplaza: 26-816575A3, 26-816575A1



18-2653
KIT RETENES CAJA ENGRANAJES
Reemplaza: 26-55682A1

-- CONTIENE --			
Ref #	Descripción	O.E.#	Cant.
18-3110	Retén	26-38970	1
18-2002	Retén	26-30550, 26-76868	2
18-2007	Retén	26-94038	1
18-2009	Retén	26-892361	1
18-2013	Retén	26-16977	1
18-2014	Retén	26-89238	1
18-2048	Retén	26-24590	1
18-2050	Retén	26-55682	1
18-2053	Retén	26-70081	1
18-2826	Junta base bomba agua a alojamiento engranaje	27-85610-1	1
18-2914	Junta bomba agua	27-85608-1	1
18-2915	Junta bomba de agua	27-85609-1	1
18-2948	Arandela	12-49221-1	1
18-7153	Aro	25-25439	1
18-7157	Aro	25-29976	1
18-7158	Aro	25-30613	1
18-7159	Aro	25-31534	1
18-7161	Aro	25-32546	1
18-7162	Aro	25-33145	1
18-7173	Aro	25-30224	1
18-2801	Junta bomba de agua	27-32438	1
18-7426	Aro	25-30271	1
18-2945	Junta tornillo drenaje	12-20260, 12-19183	2

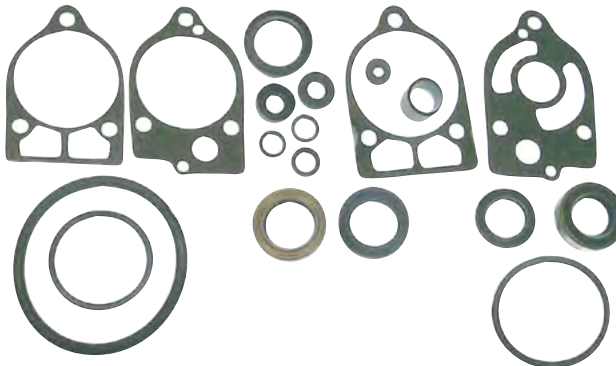

18-2654
KIT RETENES CAJA ENGRANAJE
Reemplaza: 26-79831A1

-- CONTIENE --			
Ref #	Descripción	O.E.#	Cant.
18-2008	Retén	26-56788	1
18-2011	Retén	26-90562	1
18-2048	Retén	26-24590	1
18-2051	Retén	26-69188	1
18-2052	Retén	26-69189	1
18-2054	Retén	26-816464	1
18-2055	Retén	26-79831	1
18-2823	Junta base bomba agua inferior	27-32769	1
18-2824	Junta platina superior a cuerpo de bomba	27-19551	1
18-2825	Junta base bomba de agua	27-32770	1
18-2841	Junta base bomba de agua	27-19552, 27-77417	1
18-2948	Arandela de goma	12-49221-1	1
18-7153	Aro	25-25439	1
18-7155	Aro	25-26855	1
18-7160	Aro	25-31986	1
18-7115	Aro	25-26722	1
18-2945	Junta tornillo drenaje	12-20260, 12-19183	2

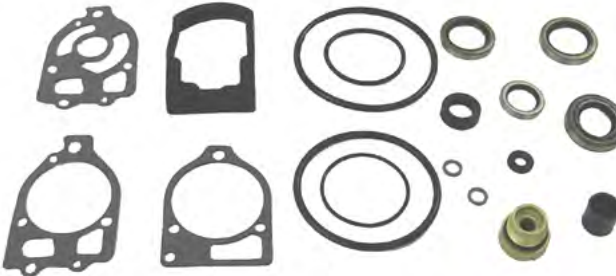

18-2655
KIT RETENES CAJA ENGRANAJE
Reemplaza: 26-89238A2

-- CONTIENE --			
Ref #	Descripción	O.E.#	Cant.
18-2155	Junta	23-77631A2	1
18-2919	Junta	27-42631-1	1
18-2002	Retén	26-30550, 26-76868	2
18-2013	Retén	26-16977	1
18-2014	Retén	26-89238	1
18-2914	Junta bomba de agua	27-85608-1	1
18-2915	Junta bomba de agua	27-85609-1	1
18-3110	Aro	26-38970	1
18-7159	Aro	25-31534	1
18-7176	Aro	25-90011	1
18-7157	Aro	25-29976	1
18-7153	Aro	25-25439	1
18-2009	Retén	26-89236	1
18-7426	Aro	25-30271	1
18-2945	Junta tornillo drenaje	12-20260, 12-19183	2



18-2697-1
KIT RETENES PARTE INFERIOR
Reemplaza: 26-41365A3

-- CONTIENE --			
Ref #	Descripción	O.E.#	Cant.
18-0581	Retén	26-413651	2
18-0584	Retén	26-66022	1
18-0585	Retén	26-821928	1
18-0586	Retén	26-99325	1
18-2728	Retén tubo agua	26-42102-1	1
18-2945	Arandela	12-19183	2
18-3149-1	Base bomba de agua	46-42040A5	1
18-4261	Arandela	19643	1
18-7162	Aro	25-33145	1



18-74501
KIT RETÉN
ALOJAMIENTO
ENGRANAJE
 Reemplaza: 27-99049M
 Para: Mariner 9.9C & 15C modelos

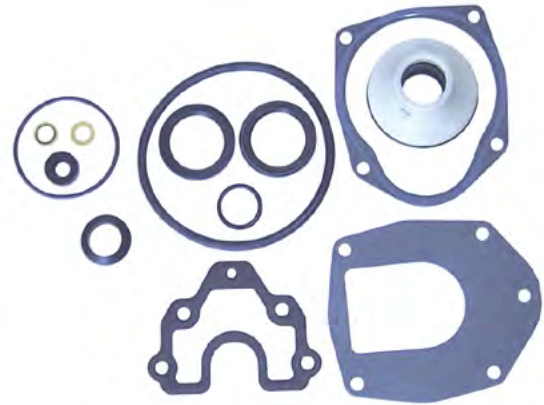

18-2725
KIT RETENES UNIDAD INFERIOR
 Reemplaza: 26-830749A01
 Para: 135/150/175 4-tiempos Verado (S/N 1B227000 & Sup), 200/225 4-tiempos Verado (S/N OT980000 & Sup), 250/275 4-tiempos Verado (S/N OT801000 & Sup)

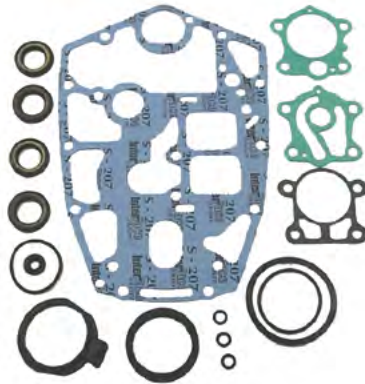

18-2787
KIT RETENES PARTE INFERIOR
 Reemplaza: 27-92648M

— CONTIENE —

Ref #	Descripción	O.E.#	Cant.
18-4698	Junta llenado/drenaje	27-81987M	3
18-0296	Retén	26-854017M	2
18-0297	Retén	26-82234M	2
18-0298	Aro	25-82275M	1
18-0299	Aro	25-82289M	1
18-0292	Junta platina a alojamiento bomba	27-81417M	1
18-0267	Retén	26-82257M	1
18-0294	Junta platina a base bomba	27-81421M	1

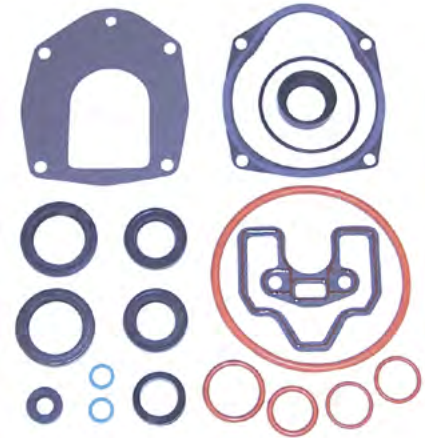

18-8382
KIT RETENES UNIDAD INFERIOR
 Reemplaza: 26-816575A4
 Para: 200 HP (T801000 & Sup), 200 HP OPTIMAX DFI (G438000 & Sup), 225 HP EFI (G438000 & Sup), 225 HP OPTIMAX DFI (G590000-G960499), 250 HP EFI (G438000 & Sup), MODELS WITH "C-3 CASTING": 200 HP OPTIMAX DFI (G386496-G437999), 225 HP (D280813-G437999), 225 HP EFI (G129222-G437999), 250 HP EFI (G129222-G437999)

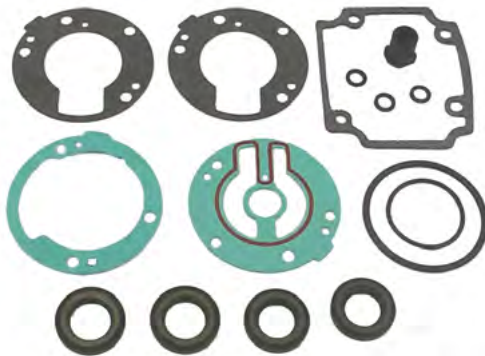

18-2785
KIT RETENES PARTE INFERIOR
 Reemplaza: 27-41899M

— CONTIENE —

Ref #	Descripción	O.E.#	Cant.
18-4698	Junta llenado/drenaje	27-81987M	3
18-0554	Retén aceite	26-84813M	1
18-0296	Retén aceite	26-854017M	2

APLICACIONES KITS RETENES ALOJAMIENTO ENGRANAJE

HP	Desde n° serie #	Hasta n° serie #	Ref #	HP	Desde n° serie #	Hasta. n° serie #	Ref #
4 (1cil)	5595532	A809600	18-2628	60 (3 cil)	6428681	D000749	18-2654
4.5 (1 cil)	4107220	& SUP	18-2628	60 (3 cil)			
6	A197112	& SUP	18-2697-1	non-Bigfoot	D000750	& SUP	18-2635
7.5	4851693	& SUP	18-2628	60 (3 cil)			
8	A197112	& SUP	18-2697-1	Bigfoot	D000750	& SUP	18-2626
8 Bodensee (4-tiempos)	G760300	T178499	18-2697-1	60 (4-tiempos) Bigfoot	T178500	& SUP	18-2626
9.8	4839254	& SUP	18-2628	60 (4-tiempos) no-Bigfoot	T178500	& SUP	18-2635
9.9	A197112	& SUP	18-2697-1	60 Seapro/ Marathon/ Big Foot (3 cil)	D000750	& SUP	18-2626
9.9 (4-tiempos) no-Bigfoot	G760300	& SUP	18-2697-1	70	4571652	A996141	18-2654
9.9 (4-tiempos) Bigfoot	G760300	& SUP	18-2624	70	A996142	& SUP	18-2626
Seapro/XR10	D038000	& SUP	18-2697-1	75 (4 cil)	6432901	& SUP	18-2653
15	A197112	& SUP	18-2697-1	75 (3 cil)	A996142	& SUP	18-2626
15 (4-tiempos) no-Bigfoot	G760300	& SUP	18-2697-1	75 (4-tiempos)	G960500	& SUP	18-2626
15 (4-tiempos) Bigfoot	G760300	& SUP	18-2624	80 (4 cil)	4831999	6432900	18-2653
Magnum/ Marathon 15XD/ Super 15	TODOS		18-2624	80 (3 cil)	A966142	& SUP	18-2626
18	5837437	6443972	18-2629	90 (6 cil)	4845301	& SUP	18-2653
18	6443973	& SUP	18-2624	90 (3 cil)	A996142	& SUP	18-2626
20	4709593	6443972	18-2627	90 (4-tiempos)	G960500	& SUP	18-2626
20	6443973	& SUP	18-2624	100 (4 cil)	B209468	& SUP	18-2626
25	5705532	6443972	18-2629	115 (6 cil)	4855153	B209467	18-2653
25	6443973	& SUP	18-2624	115 (4 cil)	C100000	& SUP	18-2626
25 Lightning (3 cil)	E268781	& SUP	18-2624	115EFI (4-tiempos)	T178500	& SUP	18-2626
30 (4-tiempos) (3 cil) Bigfoot	G760300	& SUP	18-2626	125 (4 cil)	D283222	& SUP	18-2626
35	6445653	& SUP	18-2654	V-135	A904646	& SUP	18-2655
40 (2 cil)	4860103	G053313	18-2654	V-135 DFI	G590000	& SUP	18-2655
40 (4 cil)	C159200	& SUP	18-2654	140 (6 cil)	4865678	& SUP	18-2653
40 (4-tiempos) (3 cil) Bigfoot	G760300	& SUP	18-2626	V-150	4868648	A904645	18-2653
45	5531630	& SUP	18-2654	V-150 (carb)	A904646	& SUP	18-2655
50 (4 cil)	4357640	& SUP	18-2654	V-150 XR4, XR6, MAGII, III	B242885	& SUP	18-2655
50 (3 cil)	6428681	D000749	18-2654	V-150 EFI	D820000	& SUP	18-2655
50 (3 cil)	D000750	G589999	18-2635	V-150 DFI	G590000	& SUP	18-2655
50 (4-tiempos) (4 cil) Bigfoot	G760300	& SUP	18-2626	V-175	4301235	6618750	18-2653
50 (4-tiempos) Bigfoot	G231123	& SUP	18-2626	V-175 (carb)	6618751	& SUP	18-2655
50 (4-tiempos) no-Bigfoot	T178500	& SUP	18-2635	V-175 XRI(EFI)	D000750	& SUP	18-2655
55 (3 cil)	D000750	& SUP	18-2635	V-200	4839034	6625220	18-2653
				V-200 (carb)	6625221	& SUP	18-2655
				V-200 XRI(EFI)	C100861	& SUP	18-2655
				V-200 DFI (3.0L)	G386496	G960499	18-2642
				V-220	B117316	& SUP	18-2655
				V-225	5628028	& SUP	18-2653
				V-225	D280813	& SUP	18-2646-1
				V-225/225 DFI	G386496	& SUP	18-2642
				V-250	G386496	& SUP	18-2642

KIT RETENES UNIDAD INFERIOR MARINER (Modelos japoneses)

Modelo	Serie #	O.E. Kit #	Ref #
20C	(6A9-) TODOS	27-41899M/27-95660M	18-2785
25C	(695-) TODOS	27-41899M/27-95660M	18-2785
30A	(689-) TODOS	27-41899M/27-95660M	18-2785
W48	(670-) TODOS	27-92648M	18-2787
55/W55	(663-) TODOS	27-92648M	18-2787
60	(675-) TODOS (6F0-) TODOS	27-92648M	18-2787

Retenes Aceite



Ref #	O.E. #	Tamaño Eje (pulgadas.)	Dimensiones	
			d. ext	ancho (pulgadas)
18-0531	26-72785	0.790	1.880	0.248
18-0537	26-85107	1.020	1.507	0.251
18-0554	26-84813M	0.787	1.339	0.260
18-0560 ③	26-888483	1.250	1.690	0.256
18-0564 ④	26-888483	1.250	1.690	0.256
18-0579	26-41131	1.141	1.313	0.344
18-0580	26-41132	0.750	1.250	0.312
18-0581	26-413651	0.500	0.984	0.200
18-0583	26-43035	1.063	1.496	0.197
18-0584	26-66022	0.056	1.000	0.312
18-0585	26-821928	0.687	1.125	0.312
18-0586	26-99325	0.675	1.125	0.250
18-0595	26-66303	0.688	1.125	0.250
18-2002	26-76868	1.188	1.692	0.250
18-2004	26-20070	0.625	1.000	0.250
18-2006	26-897154	0.625	1.125	0.312
18-2008	26-56788	0.875	1.250	0.375
18-2010	26-897153	0.437	0.875	0.250
18-2017	26-32121	0.750	1.000	0.125
18-2053	26-70081	1.185	1.754	0.360
18-8308	26-30696	0.297	0.625	0.156
18-8310	26-30900T	0.453	0.828	0.172
18-8347	26-8164641	0.750	0.375	0.243

① Retén ② Env. de 4 ③ Metal ④ Goma

APLICACIONES RETENES

HP	Cil.	Desde N° serie.	Hasta N° serie.	Cigüeñal superior	Cant.	Cigüeñal inferior	Cant.
3.5	1	6202173	SUP	-	-	18-0527	1
3.6	1	5404657	SUP	-	-	18-0527	1
4	1	2771622	4107219	-	-	18-0527	1
4	1	5589202	SUP	18-0515	1	-	-
4.5	1	4107220	SUP	-	-	18-0527	1
7.5/9.8/110	2	2810637	3274633	-	-	18-0527	1
10/15/20/25	2	1290910	1499331	-	-	18-2013	1
20	2	1558310	2031773	-	-	18-2013	2
20	2	2031774	2827677	-	-	18-2013	2
18,20,25XD	2	6443973	SUP	-	1	18-0537	1
20 JET	2	G053314	SUP	-	1	18-0537	1
30	2	1271885	1356947	18-2016	1	18-2016	1
30JET	2	C159200	SUP	18-2016	1	18-2016 ①	2
MK 35 A	2	1217222	1271884	18-2016	1	18-2016	1
35	2	1356948	1571113	18-2016	1	18-2016	1
35	2	1571114	2874703	-	-	18-2016 (Inferior)	1
35	2	6445653	SUP	18-2016	1	18-2016	2
40	4	1279685	2874703	18-2016	1	18-2016	1
40	2	2874704	3336257	18-2016	1	18-2016	2
40	2	3336258	4117709	18-2016	1	18-2016	1
40	2	4117710	5556229	18-2016	1	18-2016	1
40	2	5556230	6445653	18-2016	1	18-2016	2
40	4	C159200	SUP	18-2016	1	18-2016 ①	2
45	4	1476510	1531568	18-2016	1	18-2016	1
45	4	5531630	SUP	18-2016	1	18-2016	2
45 JET	3	Todos	-	-	-	18-2016 (inf.)	1
50	4	1421113	2858813	18-2016	1	18-2016 (inf.)	1
50	4	2855514	SUP	18-2016	1	18-2016	2
50/60	3	6428681	D000750	18-2016	1	18-2016	2
50/55/60	3	D000750	SUP	-	-	18-2016 (inf.)	1
60	6	1303411	1542744	18-2016	1	18-2016	1
65	4	1542745	2803561	18-2016	1	18-2016 (inf.)	1
65	4	2803562	3293183	18-2016	1	18-2016	2
65	3	3293184	3547986	18-2016	1	18-2016	2
65	3	3547987	4571651	18-2016	1	18-2016	2
65 JET	3	D283222	SUP	18-0523	1	18-2016	1

① Para mayoría modelos

APLICACIONES RETENES (Cont.)

HP	Cil.	Desde n° Serie.	Hasta n° serie.	Cigüeñal Superior	Cant.	Cigüeñal Inferior	Cant.
70	6	1296411	1566239	18-2016	1	18-2016 (Int.)	1
70	3	4571652	6428680	18-2016	1	18-2016	2
70	3	A996142	SUP	18-0523	1	18-2016	1
75	4	6432901	A996141	18-2016	1	18-2016	2
75	3	A996142	D283221	18-0523	1	18-2016	1
75	3	D283222	SUP	18-0523	1	18-2016	1
80	6	1335465	1566239	18-2016	1	18-2016	1
80	4	2559001	4831998	18-2016	1	18-2016	2
80	4	4831999	SUP	18-2016	1	18-2016	2
80	3	A996142	SUP	18-0523	1	18-2016	1
80 JET	4	D283222	SUP	18-0523	1	18-2016	1
85	6	1460999	1766823	18-2016	1	18-2016	1
85	4	3493913	4831998	18-2016	1	18-2016	2
90	6	1766824	1869775	18-2016	1	18-2016 (ext.)	1
90	6	4845301	A996141	18-2016	1	18-2016	2
90	3	A996142	D283221	18-0523	1	18-2016	1
90	3	D283221	SUP	18-0523	1	18-2016	1
95	6	1869776	2318585	18-2016	1	18-2016 (int.)	1
100	6	1464949	2836018	18-2016	1	18-2016	1
100BP	6	2641855	3253111	18-2016	1	18-2016	2
100	4	B209468	D283221	18-0523	1	18-2016	1
100	4	D283222	SUP	18-0523	1	18-2016	1
105JET	V-6	D082000	SUP	18-2016	1	18-2016	2
110	6	1870204	2314955	18-2016	1	18-2016	1
115	6	2836019	3525440	18-2016	1	18-2016	2
115	6	3525441	C100000	18-2016	1	18-2016	2
125	6	2314956	3253111	18-2016	1	18-2016 (int.)	1
135	6	2839369	3293233	18-2016	1	18-2016	2
135	V-6	A904646	SUP	18-2016	1	18-2016	2
140	6	3293234	SUP	18-2016	1	18-2016	2
140JET	V-6	D082000	SUP	18-2016	1	18-2016	2
150	6	3502806	5327662	18-2016	1	18-2016	2
150	V-6	4868998	6042945	18-2016	1	18-2016	2
150	V-6	6042946	SUP	18-2016	1	18-2016	2
175	V-6	4301235	5875203	18-2016	1	18-2016	2
175	V-6	5875204	6618751	18-2016	1	18-2016	2
175	V-6	6618751	SUP	18-2016	1	18-2016	2
200	V-6	4839034	5875303	18-2016	1	18-2016	2
200	V-6	5875303	6073191	18-2016	1	18-2016	2
200	V-6	6073192	SUP	18-2016	1	18-2016	2
220	V-6	B117316	SUP	18-2016	1	18-2016	2
225	V-6	5628028	SUP	18-2016	1	18-2016	2

① Adapta a mayoría mod.

APLICACIONES RETENES UNIDAD INFERIOR

HP	Desde N° Serie.	Hasta N° Serie.	Eje hélice Interno/Externo	Base bomba de agua Superior/ Inferior	Alojamiento Bomba agua	Eje Cambio
3.5/3.6	5404657	SUP	-	18-2010	18-0516	-
3.9	1655013	2498135	18-0515	-	18-0516	-
4	2498136	5589201	18-0515	-	18-0516	-
4	5589202	5595531	-	18-2010	18-0516	-
4/4.5	5589203	A809601	-	18-2010	② 18-0516	-
6	1408611	2529894	18-0515	-	18-0516	-
7.5	2529895	3801457	18-0515	-	18-0516	-
7.5	3801458	5206549	-	-	18-0516	-
7.5	5206550	SUP	-	18-2010	② 18-0516	-
9.8	1470349	3795657	18-0515	-	18-0516	-
9.8	3795658	5206549	-	-	18-0516	-
9.8	5206550	SUP	-	18-2010	② 18-0516	-
18	5837437	6443972	-	18-2006/18-2006	-	-
20	1558310	1866494	18-2019/18-2019	18-2006	18-2004	-
20	1866495	6443972	18-2019/18-2019	18-2004/18-2006	18-2004	-
25	5705532	6443972	-	18-2006/18-2006	-	-
30	1271885	1356947	18-2011	18-2011	18-2015	18-2009
30	G055314	SUP	18-2051/18-2052	-	-	-
MK 35A	1217222	1271884	18-2011	18-2011	18-2015	18-2009
35	1356948	1448139	18-2011	18-2011	18-2015	18-2009
35	1571114	1960826	18-2011	18-2011	18-2017	18-2009
35	1960827	2874703	18-2011/18-2015	18-2011/18-2055	18-2017	18-2009
35	6445653	SUP	18-2051/18-2052	18-2011/18-2055	-	18-2054
40	1279685	2874703	18-2011	18-2011	18-2015	18-2009
40	2874704	3336257	18-2008	18-2011/18-2055	18-2017	18-2009
40	3336258	4117709	18-2008	18-2011/18-2055	18-2017	18-2048
40	4117710	4860102	18-2051/18-2052	18-2011/18-2055	-	18-2009/18-2048

② .438 DI solo

APLICACIONES RETENES UNIDAD INFERIOR (Cant.)

HP	Desde n° serie.	Hasta n° serie.	Eje hélice Int/Ext	Base bomba agua Superior/Inferior	Alojamiento Bomba agua	Eje cambio
40	4860103	6445652	18-2051/18-2052	18-2011/18-2055	-	18-2054
40 4cil	C159200	G053313	18-2051/18-2052	18-2011/18-2055	-	18-2054
40 2cil	G055314	SUP	18-2051/18-2052	-	-	-
45	1476510	1531568	18-2011	18-2011	18-2017	18-2009
45 4cil	5531630	SUP	18-2051/18-2052	18-2011/18-2055	-	18-2054
50	1421113	1639472	18-2011	18-2011	18-2017	18-2009
50	1639473	1770178	18-2011	18-2011	18-2017	18-2009
50	1770179	2305100	18-2011/18-2015	18-2011/18-2055	18-2017	18-2009
50	2305101	2858813	18-2011/18-2015	18-2011/18-2055	18-2017	18-2048
50	2858814	4140999	18-2008	18-2011/18-2055	18-2017	18-2009/18-2048
50	4141000	4962055	18-2051/18-2052	18-2011/18-2055	-	18-2009/18-2048
50	4962056	5531630	18-2051/18-2052	18-2011/18-2055	-	18-2054
50 3cil	6428681	D000750	18-2051/18-2052	18-2011/18-2055	-	18-2054
50/55/60 3 cil	D000751	SUP	18-2051/18-2052	-	-	18-2054
60	1303411	1542744	-	18-2011	18-2015	-
60	6428681	D000750	18-2051/18-2052	18-2011/18-2055	-	18-2054
65	1542745	2874263	18-2002/18-2002	18-2007	18-2013	18-2009
65	2874263	3293183	18-2002/18-2002	18-2007/18-2050	18-2013	18-2009/18-2048
65 3cil	3293184	4136684	18-2008	18-2011/18-2055	18-2017	18-2009/18-2048
65 3cil	4136685	4571651	18-2051/18-2052	18-2011/18-2055	18-2017	18-2009/18-2048
70	1296411	1413610	18-2011	-	18-2015	-
70	1413611	1566239	18-2002/18-2002	18-2007	18-2013	18-2009
70 3cil	4571652	4977156	18-2051/18-2052	18-2011/18-2055	-	18-2009/18-2048
70 3cil	4977157	5579016	18-2051/18-2052	18-2011/18-2055	-	18-2054
70 3cil	5579017	A996142	18-2051/18-2052	18-2011/18-2055	-	18-2009
70/75 3cil	A996142	SUP	18-2002/18-2053	18-0522 (inferiores)	-	--
75 4cil	6432901	A996142	18-2002/18-2053	18-2013/18-2007	-	18-2054
80	1335465	1398629	18-2002/18-2002	18-2007	18-2013	18-2009
80	1398630	1566239	18-2002/18-2002	18-2007	18-2013	18-2009
80 4cil	2559001	3144218	18-2002/18-2002	18-2013/18-2007	18-2013	18-2009/18-2048
80 4cil	3144219	4831998	18-2002/18-2002	18-2050/18-2007	18-2013	18-2009/18-2048
80 4cil	4831999	5582561	18-2002/18-2002	18-2013/18-2007	-	18-2054
80 4cil	5582562	A996142	18-2002/18-2053	18-2013/18-2007	-	18-2054
80 3cil	A996142	SUP	18-2002/18-2053	18-0522 (inferiores)	-	--
85	1460999	1766823	18-2002/18-2002	18-2007	18-2013	18-2009
85 4cil	3493913	4590511	18-2002/18-2002	18-2050/18-2007	-	18-2009/18-2048
85 4cil	4590512	4831998	18-2002/18-2002	18-2013/18-2007	-	18-2009/18-2048
90	1766824	1869775	18-2002/18-2002	18-2013/18-2007	18-2013	18-2009
90	4845301	5594656	18-2002/18-2002	18-2013/18-2007	-	18-2054
90	5594657	A996142	18-2002/18-2053	18-2013/18-2007	-	18-2054
90 3cil	A996142	SUP	18-2002/18-2053	18-0522 (inferiores)	-	--
95	1869776	2318585	18-2002/18-2002	18-2013/18-2007	18-2013	18-2009/18-2048
100,100SS	1464949	2836018	18-2002/18-2002	18-2013/18-2007	18-2013	18-2009
100BP	2399698	2641854	18-2002/18-2002	18-2013/18-2007	18-2013	18-2009/18-2048
100 4cil	B209468	SUP	18-2002/18-2053	18-0522 (inferiores)	-	--
110	1870204	2314955	18-2002/18-2002	18-2013/18-2007	18-2013	18-2009/18-2048
115	2836019	3525440	18-2002/18-2002	18-2013/18-2007	18-2013	18-2009/18-2048
115	3525440	4112634	18-2002/18-2002	18-2013/18-2007	-	18-2009/18-2048
115	4112635	4855152	18-2002/18-2002	18-2013/18-2007	-	18-2009/18-2048
115	4855153	5600966	18-2002/18-2002	18-2013/18-2007	-	18-2054
115	5600967	C100000	18-2002/18-2053	18-2013/18-2007	-	18-2054
115 4cil	C100000	SUP	18-2002/18-2053	18-0522 (inferiores)	-	--
125	2314956	2839368	18-2002/18-2002	18-2013/18-2007	18-2013	18-2009
135	2839369	3293233	18-2002/18-2002	18-2013/18-2007	18-2013	18-2009
140	3293234	3502805	18-2002/18-2002	18-2013/18-2007	18-2013	18-2009/18-2048
140	4865678	SUP	18-2002/18-2002	18-2013/18-2007	-	18-2054
150	3502806	4121434	18-2002/18-2002	18-2013/18-2007	-	18-2009/18-2048
150	4121434	5327662	18-2002/18-2002	18-2013/18-2007	-	18-2009/18-2048

V-6'S

150/150XR2	4868998	5432021	18-2002/18-2002	18-2013/18-2014	-	18-2054
150/150XRS	5432021	A904646	18-2002/18-2002	18-2013/18-2014	-	18-2054
135/150/XR2	A904646	SUP	18-2002/18-2002	18-2013/18-2014	-	18-2054
175	4301235	6618750	18-2002/18-2002	18-2013/18-2014	-	18-2054
175	6618751	SUP	18-2002/18-2002	18-2013/18-2014	-	18-2054
200	4839034	6073191	18-2002/18-2002	18-2013/18-2014	-	18-2054
200	6073192	SUP	18-2002/18-2002	18-2013/18-2014	-	18-2054
220	B117316	SUP	18-2002/18-2002	18-2013/18-2014	-	18-2054
225	5628028	D280813	18-2002/18-2002	18-2013/18-2014	-	18-2054
250/275	C101891	SUP	18-2002/18-2002	-	-	18-2054
3.4	5611648	SUP	18-2002/18-2002	-	-	18-2054

RETÉN ACEITE POWER TRIM

H.P.	Desde S/N	Hasta S/N	Retenes Aceite	Cant.	Descripción
115	2836019	3525440	18-2048	1	Soporte montaje estribor
140	3293234	SUP	18-2048	1	Soporte montaje estribor
150	3502806	4865677	18-2048	1	Soporte montaje estribor
150 XS	4868648	5327662	18-2048	1	Soporte montaje estribor

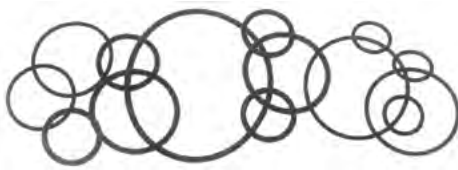

AROS

Ref #	O.E. #	Dimensiones	
		D.I.	Ancho (pulgadas)
18-0858	25-54029	2.425	.103
18-0860	25-62700	3.237	.103
18-7102	25-62706	.426	.070
18-7103	25-29845	.924	.103
18-7105	25-62705	.750	.065
18-7107	25-67202	4.750	.135
18-7114	25-23145	1.000	.135
18-7115	25-26722	1.735	.135
18-7116	25-62704	.360	.100
18-7117	25-35027	1.046	.139
18-7120	25-38933	.215	.065
18-7121	25-35029	3.100	.135
18-7124		2.500	.103
18-7125		2.300	.103
18-7135	25-35276	.750	.135
18-7143	25-65936	1.310	.100
18-7145	25-64068	.250	.100
18-7146	25-47632	1.120	.100
18-7151	25-20081	3.000	.135
18-7152	25-20863	2.625	.135
18-7153	25-21836	.862	.103
18-7155	25-26855	1.620	.135
18-7156	25-29439	1.185	.100
18-7157	25-29976	3.500	.210
18-7158	25-30613	.740	.100
18-7159	25-31534	3.855	.210
18-7160	25-31986	2.635	.210
18-7161	25-32546	3.250	.070
18-7162	25-33145	2.025	.135

Ref #	O.E. #	Dimensiones	
		D.I.	Ancho (pulgadas)
18-7163	25-33465	2.415	.100
18-7164	25-33466	1.375	.100
18-7165	25-45253	.500	.065
18-7165	25-32509	.500	.065
18-7166	25-45254	.615	.065
18-7167	25-861844	3.609	.139
18-7168	25-48171	.370	.065
18-7169	25-70937	3.500	.135
18-7170	25-33504	1.365	.135
18-7171	25-30529	1.920	.100
18-7172	25-31305	3.250	.135
18-7173	25-30224Q	1.875	.135
18-7174	25-45711	.620	.100
18-7175	25-62817	3.750	.270
18-7176	25-896523	2.160	.100
18-7177	25-53421	2.625	.065
18-7180	25-26802	.445	.090
18-7188	25-805726	.361	.0635
18-7195	25-8010027717	2.75	0.07
18-7198	25-45710	1.430	.100
18-7410	25-36390-0	676	0.07
18-7411	25-35480	1.250	.100
18-7413	25-62702	.301	.070
18-7414	25-823683	1.989	.070
18-7419	25-69202	2.675	.103
18-7420	25-25439	.862	.139
18-7421	25-16524	.150	.065
18-7426	25-30271	.740	.310
18-7440-1	25-36318	.799	.103
18-7449	25-97387	4.487	.103
18-7459	25-20826	2.234	.139
18-7464	25-39695	4.234	.139
18-7467	25-54030	2.987	.103
18-7474	25-94288	1.239	.070
18-7956	25-85549	2.480	.1969
18-7100	25-85594	.2362	.1575
18-7961	25-47254	3.650	.135
18-76695	25-803513007		

① Env. de 1 ② Env. de 5 ③ Env. de 2

AROS MARINER (Modelos Japoneses)

Ref.	O.E. No.	Dimensiones		Ref.	O.E. No.	Dimensiones	
		D. I.	Ancho (mm)			D. I.	Ancho (mm)
18-0298	25-82275M	41.50	3.0	18-0299	25-82289M	66.04	5.33

APLICACIONES AROS Y RETENES

Modelo	Desde n° Serie #	Hasta n° Serie #	Aro tórico inf.	Retén aceite inf.	Aro tórico sup.	Retén aceite sup.
3.5 (1cil)	6202173	& SUP	N/D	N.L.A.	18-7152	N/D
3.9 (39) (1cil)	1655013	2498135	N/D	N.L.A.	18-7152	N.L.A.
4 (1cil)	1655013	2498135	N/D	N/D	18-7152	N/D
4 (40) (1cil)	2498136	2693114	N/D	N.L.A.	18-7152	N.L.A.
4 (1cil)	2771622	4107219	N.L.A.	N/D	18-7152	N.L.A.
4 (40) (2cil)	5589202	& SUP	18-7102	N/D	N/D	18-0515
4.5 (4.5, 45) (1cil)	4107220	4597261	N/D	N/D	18-7152	N.L.A.
4.5 (4.5, 45) (1cil)	4597262	5595531	N/D	N.L.A.	18-7152	N/D
4.5 (4.5, 45) (1cil)	5595532	& SUP	N/D	N.L.A.	18-7152	N/D
6 (60)	1916139	2529894	N/D	N.L.A.	18-7459	N.L.A.
6 (2cil)	1408611	2529894	N/D	N/D	18-7152	N/D
7.5 (75)	2529895	2721150	N/D	N.L.A.	18-7152	N.L.A.
7.5 (2cil)	2810637	3801457	N/D	N.L.A.	18-7152	N/D
7.5 (75) (2cil)	3274633	& SUP	N/D	N/D	18-7152	N/D
7.5 (7.5, 75)	3801458	& SUP	N/D	N/D	18-7152	N/D
9.8 (110)	1865779	2798056	N/D	N.L.A.	18-7152	N.L.A.
9.8 (110)	2798057	3795657	N/D	N.L.A.	18-7152	N/D
9.8 (2cil)	2810637	3274633	N/D	N/D	18-7152	N/D
9.8 (9.8, 110)	3795658	& SUP	N/D	N/D	18-7152	N/D
9.8 (2cil)	3274633	& SUP	N/D	N/D	18-7152	N/D
10 (100)	1290910	1499331	N/D	18-2026	N.L.A.	N.L.A.
110 (2cil)	2810637	3274633	N/D	N/D	18-7152	N/D
110 (2cil)	3274633	& SUP	N/D	N/D	18-7152	N/D
15 (150)	1290910	1499331	N/D	18-2026	N.L.A.	N.L.A.
15 (SEA PRO)	G044365	G437999	N/D	18-0537	N/D	N/D
15 (SEA PRO)	G438000	& SUP	N/D	26-12566 1	N/D	N/D
15 (SUPER)	B238464	& SUP	N/D	18-0537	N/D	N/D
15 (18, 18XD)	5837437	& SUP	N/D	18-0537	N/D	N/D
20 (200)	1290910	1499331	N/D	18-2026	N.L.A.	N.L.A.
20 (200)	1558310	2031773	N/D	18-2026	N.L.A.	N/D

④ Precio por pieza. Para pedir envasado añada 9 al final de la referencia.

APLICACIONES AROS Y RETENES (Cont.)

Modelo	Desde n° Serie #	Hasta n° Serie #	Aro tórico inf.	Retén aceite inf.	Aro tórico sup.	Retén aceite sup.
20 (2cil)	2031774	2827677	N/D	N/D	18-7151	N/D
20 (20, 200)	2827677	6443972	N/D	18-2056	18-7151	N/D
20 (20, 20XD)	6443973	T800749	N/D	18-0537	N/D	N/D
20 JET	G044027	& SUP	N/D	18-0537	N/D	N/D
25 (250)	1290910	1499331	N/D	18-2026	N.L.A.	N.L.A.
25 (25, 25XD) (2cil)	5705532	& SUP	N/D	18-0537	N/D	N/D
30 (2cil)	1271885	1448139	18-7151	N.L.A.	18-7151	18-2016
30 (2cil) 644cc	G053314	& SUP	18-7176	18-2016	N/D	N/D
30 (2cil) 430cc	G575500	& SUP	N/D	18-2016	N/D	N/D
30 JET (4cil)	C159200	D279349	18-7161	18-2016	18-7151	18-2016
30 JET (4cil)	D279350	& SUP	18-7161	18-2016	18-7151	18-2016
30 JET (3cil)	G531301	& SUP	18-7176	18-2016	N/D	N/D
MK 35A (2cil)	1217222	1271884	18-7151	N/D	18-7151	N/D
35 (350)	1271884	1448139	18-7151	N.L.A.	18-7151	18-2016
35 (2cil)	1356948	1571113	18-7151	N/D	18-7151	N/D
35 (2cil)	1571114	2874703	18-7151	N/D	18-7172	N.L.A.
35 (2cil)	6445653	& SUP	18-7414	18-2016	18-7167	18-2016
40 (402) (2cil)	1279685	1476509	18-7151	N/D	18-7151	18-2016
40 (4cil)	1279685	2874703	18-7151	N/D	18-7151	N/D
40 (2cil)	2874704	3336257	N/D	18-2016	18-7167	18-2016
40 (2cil)	3336258	3346479	N/D	18-2016	18-7961	18-2016
40 (2cil)	3336258	4117709	N/D	N/D	18-7167	N/D
40 (2cil)	4117710	& SUP	18-7414	18-2016	18-7167	18-2016
40 (2cil)	5556230	6445653	18-7414	N/D	18-7167	N/D
40 (4cil)	C159200	D279349	18-7161	18-2016	18-7151	18-2016
40 (402) (2cil)	3477010	4117709	N/D	18-2016	N/D	18-2016
40 (2cil) 644cc	G053314	& SUP	18-7176	18-2016	N/D	N/D
40 (4cil)	D279350	& SUP	18-7161	18-2016	18-7151	18-2016
40 (3cil)	G531301	& SUP	18-7176	18-2016	N/D	N/D
45 (450) (4cil)	1476510	1531568	18-7151	N.L.A.	18-7151	18-2016
45 (4cil)	5531630	& SUP	18-7151	18-7151	18-7151	18-2016
45 JET	D000750	G589999	18-7176	18-2016	18-7176	N/D
45 JET	G590000	& SUP	18-7176	18-2016	N/D	N/D
50 (500) (4cil)	1421113	1639472	18-7151	18-7151	18-7151	18-2016
50 (500) (4cil)	1639473	2858813	18-7151	N/D	18-7151	18-2016
50 (50, 500) (4cil)	2855514	& SUP	18-7151	18-2016	18-7151	18-2016
50 (3cil)	D000750	G589999	18-7176	18-2016	N/D	N/D
50 (3cil)	6428681	D000750	18-7161	18-2016	18-7415	18-2016
50 (3cil)	D000750	& SUP	18-7176	N/D	N/D	N/D
50 (3cil)	G590000	& SUP	18-7176	18-2016	N/D	N/D
55 (3cil)	D000750	G589999	18-7176	18-2016	N/D	N/D
55 (3cil)	G590000	& SUP	18-7176	18-2016	N/D	N/D
60 (3cil)	6428681	D000749	18-7161	18-2016	18-7415	18-2016
60 (3cil)	D000750	& SUP	18-7176	N/D	N/D	N/D
60 (600) (4cil)	1303411	1542744	18-7151	N/D	18-7151	18-2016
60 (3cil)	D000750	G589999	18-7176	18-2016	N/D	N/D
65 (650) (4cil)	1542745	2803561	18-7151	N/D	18-7172	18-2016
65 (650) (4cil)	2803562	3203183	18-7151	18-2016	18-7172	18-2016
65 (650) (3cil)	3293184	4571651	18-7161	18-2016	18-7167	18-2016
65 (3cil)	3547987	4571651	18-7161	N/D	18-7415	N/D
65 JET	D283222	& SUP	N/D	18-2016	18-7414	18-0523
70 (700) (6cil)	1296411	1566239	18-7151	N/D	18-7151	18-2016
70 (3cil)	4571652	6428680	18-7161	18-2016	18-7415	18-2016
70 (3cil)	A996142	B240450	N/D	18-2016	18-7414	18-0523
70 (3cil)	B240451	& SUP	18-0858	18-2016	18-7414	18-0523
75 (4cil)	6432901	& SUP	18-7161	18-2016	18-7961	18-2016
75 (3cil)	C222000	& SUP	N/D	18-2016	18-7414	18-0523
80 (800) (6cil)	1335465	1566239	18-7151	N/D	18-7151	18-2016
80 (800) (4cil)	2559001	3493912	18-7151	18-2016	18-7961	18-2016
80 (80, 800) (4cil)	4831999	6432900	18-7161	18-2016	18-7961	18-2016
80 (3cil)	A996142	B240450	N/D	18-2016	18-7414	18-0523
80 (3cil)	B240451	& SUP	18-0858	18-2016	18-7414	18-0523
80 JET	D283222	G760299	N/D	18-2016	18-7414	18-0523
80 JET Aro superior redondo	G760300	& SUP	N/D	18-2016	18-7414	18-0523
80 JET Aro superior cuadrado	G760300	& SUP	N/D	18-2016	N/D	18-0523
85 (850) (6cil)	1460999	1464848	18-7151	N/D	18-7151	18-2016
85 (850) (6cil)	1566240	1766823	18-7151	N/D	N.L.A.	18-2016
85 (850) (4cil)	3493913	4831998	18-7161	18-2016	18-7961	18-2016
90 (900) (6cil)	1766824	1869775	18-7151	N/D	N.L.A.	18-2016
90 (90, 900) (6cil)	4845301	& SUP	18-7161	18-2016	18-7961	18-2016
90 (3cil)	A996142	B240450	N/D	18-2016	18-7414	18-0523
90 (3cil)	B240451	C221999	18-0858	18-2016	18-7414	18-0523
90 (3cil)	C222000	& SUP	N/D	18-2016	18-7414	18-0523
95 (950) (6cil)	1869776	2318585	18-7151	N/D	N.L.A.	18-2016

APLICACIONES AROS Y RETENES (Cont.)

Modelo	Desde n° Serie #	Hasta n° Serie #	Aro tórico inf.	Retén aceite inf.	Aro tórico sup.	Retén aceite sup.
100 (1000) (6cil)	1464949	2318585	18-7151	N/D	N.L.A.	18-2016
100 (1000SS) (6cil)	2318586	2413847	18-7151	N/D	N.L.A.	18-2016
100 (1000SS) (6cil)	2484633	2836018	18-7151	18-2016	N.L.A.	18-2016
100 (1000BP) (6cil)	2399698	2641854	18-7151	18-2016	N.L.A.	18-2016
100 (1000BP) (6cil)	2641855	3253111	18-7151	18-2016	18-7961	18-2016
100 (4cil)	B209468	G760299	N/D	18-2016	18-7414	18-0523
100 w/Aro superior redondo	G760300	& SUP	N/D	18-2016	18-7414	18-0523
100 w/Aro superior cuadrado	G760300	& SUP	N/D	18-2016	25-858225	18-0523
110 (1100)	1870201	2314955	18-7151	N/D	N.L.A.	18-2016
115 (1150) (6cil)	2836019	3525440	18-7151	18-2016	18-7961	18-2016
115 (115, 1150) (6cil)	3525441	& SUP	18-7161	18-2016	18-7961	18-2016
115 (4cil)	C100000	G760299	N/D	18-2016	18-7414	18-0523
115 w/Aro superior redondo	G760300	& SUP	N/D	18-2016	18-7414	18-0523
115 w/Aro superior cuadrado	G760300	& SUP	N/D	18-2016	N/D	18-0523
115 DFI (1.5L)	T801000	& SUP	N/D	18-2016	N/D	N/D
115 PRO XS	B751825	& SUP	N/D	18-2016	N/D	N/D
125 (1250) (6cil)	2314956	2839368	18-7151	N/D	18-7961	18-2016
125 (4cil)	D283222	G760299	N/D	18-2016	18-7414	18-0523
125 w/ROUND UPPER O-RING (4cil)	G760300	& SUP	N/D	18-2016	18-7414	18-0523
125 w/SQUARE UPPER O-RING (4cil)	G760300	& SUP	N/D	18-2016	N/D	18-0523
135 (1350) (6cil)	2839369	3293233	18-7151	18-2016	18-7961	18-2016
140 (140, 1400) (6cil)	3293234	& SUP	18-7161	18-2016	18-7961	18-2016
150 (1500) (6cil)	3502806	4865677	18-7161	18-2016	18-7961	18-2016
150 (1500XS) (6cil)	4868648	5327662	18-7161	18-2016	18-7961	18-2016
V-105 JET	D082000	& SUP	18-0860	18-2016	18-0858	18-2016
V-135 CARB w1.50 ID Cojinete sup.	A904646	C100860	18-0860	18-2016	18-0858	18-2016
V-135 CARB w1.37 ID Cojinete sup.	A904646	C100860	18-0860	18-2016	18-0858	18-2016
V-135 CARB	C100861	& SUP	18-0860	18-2016	18-0858	18-2016
V-135 CARB	C239553	& SUP	18-0860	18-2016	18-0858	18-2016
V-135 DFI	G590000	& SUP	18-0860	18-2016	18-0858	18-2016
V-140 JET	D082000	& SUP	18-0860	18-2016	18-0858	18-2016
V-150 (V-1500) CARB	4868998	A904645	N/D	18-2016	N/D	18-2016
V-150 w/1.50 ID Cojinete sup.	A904646	C100860	18-0860	18-2016	18-0858	18-2016
V-150 w/1.37 ID Cojinete sup.	A904646	C100860	18-0860	18-2016	18-0858	18-2016
V-150 CARB	C100861	C239552	18-0860	18-2016	18-0858	18-2016
V-150 XR4 / MAGNUM II	B242885	C239552	18-0860	18-2016	18-0858	18-2016
V-150 CARB	C239553	& SUP	18-0860	18-2016	18-0858	18-2016
V-150 XR4 / 6 MAG II, III	C239553	& SUP	18-0860	18-2016	18-0858	18-2016
V-150 EFI	D082000	& SUP	18-0860	18-2016	18-0858	18-2016
V-150 DFI	G590000	& SUP	18-0860	18-2016	18-0858	18-2016
V-175 (V-175, 1750) CARB	4301235	5393736	N/D	18-2016	N/D	18-2016
V-175 CARB	5393737	6618750	N/D	18-2016	N/D	18-2016
V-175 CARB	6618751	C239552	18-0860	18-2016	18-0858	18-2016
V-175 CARB	C239553	& SUP	18-0860	18-2016	18-0858	18-2016
V-175 EFI	D000750	& SUP	18-0860	18-2016	18-0858	18-2016
V-175 DFI	T178500	& SUP	18-0860	18-2016	18-0858	18-2016
V-175 PRO XS	B516339	& SUP	18-0860	18-2016	18-0858	18-2016
V-200 (V-200, 2000) CARB	4839034	5363917	25-67207	18-2016	N/D	18-2016
V-200 CARB	5363918	6073191	N/D	18-2016	N/D	18-2016
V-200 CARB	6073192	C291519	18-0860	18-2016	18-0858	18-2016
V-200 CARB	C291520	& SUP	18-0860	18-2016	18-0858	18-2016
V-200 EFI	C100861	C291519	18-0860	18-2016	18-0858	18-2016
V-200 EFI (2.5L)	C291520	& SUP	18-0860	18-2016	18-0858	18-2016
V-200 DFI	G386496	& SUP	18-0860	N/D	18-7414	N/D
V-200 PRO XS	B504989	& SUP	18-0860	N/D	18-7414	N/D
V-200 LASER	B117316	& SUP	18-0860	18-2016	18-0858	18-2016
V-225 (2.4L)	5628028	& SUP	18-0860	18-2016	N/D	18-2016
V-225 (3.0L) SEA PRO / MARATHON CARB	G245605	G303045	18-0860	N/D	18-7414	N/D
V-225 (3.0L) SEA PRO / MARATHON CARB	G303046	& SUP	18-0860	N/D	18-7414	N/D
V-225 DFI	G590000	& SUP	18-0860	N/D	18-7414	N/D
V-225 PRO XS	B104549	& SUP	18-0860	N/D	18-7414	N/D
V-225 EFI	G129222	G303045	18-0860	N/D	18-7414	N/D
V-225 EFI	G303046	& SUP	18-0860	N/D	18-7414	N/D
V-250 w/o Cojinete sup.	C101891	& SUP	N/D	N.L.A.	18-7414	18-2016
V-250 w/Cojinete sup.	C101891	& SUP	N/D	N.L.A.	18-7414	18-2016
V-250 EFI	G129222	G303045	18-0860	N/D	18-7414	N/D
V-250 EFI	G303046	& SUP	18-0860	N/D	18-7414	N/D
V-250 DFI	B528615	& SUP	18-0860	N/D	18-7414	N/D
V-250 PRO XS	B426561	& SUP	18-0860	N/D	18-7414	N/D
V-275 CARB w/o Cojinete sup.	C101891	& UP	N/D	N.L.A.	18-7414	N/D
V-275 CARB w/Cojinete sup.	C101891	& UP	N/D	N.L.A.	18-7414	N/D
V-300 (3.4L)	5611648	& UP	N/D	N.L.A.	18-7414	N/D

APLICACIÓN DE AROS DE UNIDAD INFERIOR

HP	Desde N° Serie.	Hasta N° Serie.	Aro tórico Cojinete	Base bomba de agua	Cambio Eje	Eje Dirección
3.9	1655013	2498135	18-7121	18-7156	18-7180	18-7168
4	2498136	5589201	18-7121	18-7156	18-7180	18-7168
4/4.5	5589203	A809601	18-7171	18-7156	18-7180	-
6	1408611	2529894	18-7171	18-7156	18-7180	18-7168
6	A197112	SUP	18-7162	-	-	-
7.5	2529895	3801457	18-7171	18-7156	18-7180	18-7168
7.5	3801458	5206549	18-7171	18-7156	18-7180	-
7.5	5206550	SUP	18-7171	18-7156	18-7180	18-7116
8	A197112	SUP	18-7162	-	-	-
9.8	1470349	3795657	18-7171	18-7156	18-7180	18-7168
9.8	3795658	5206549	18-7171	18-7156	18-7180	-
9.8	5206550	SUP	18-7171	18-7156	18-7180	18-7116
9.9/15	A197112	SUP	18-7162	-	-	-
18	5837437	6443972	-	18-7419	-	-
20	1558310	1866494	18-7163	18-7164	18-7180	18-7180
20	1866495	6443972	18-7163	18-7164	18-7180	18-7180
25	5705532	6443972	-	18-7419	-	-
18/20/25XD	6443973	SUP	-	18-7419	18-7135 ②	-
30	1271885	1356947	18-7152	18-7115	18-7153	-
30	G055314	SUP	-	-	18-7155 ②	-
MK 35A	1217222	1271884	18-7152	18-7115	18-7153	-
35	1356948	1448139	18-7152	18-7115	18-7153	-
35	1571114	1960826	18-7160	18-7155	18-7153	-
35	1960827	2874703	18-7160	18-7155	18-7153	-
35	6445653	SUP	18-7160	18-7115	18-7153	-
40	1279685	2874703	18-7152	18-7115	18-7153	-
40	2874704	3336257	18-7160	18-7155	18-7153	-
40	3336258	4117709	18-7160	18-7155	18-7153	-
40	4117710	4860102	18-7160	18-7155	18-7153	-
40	4860103	6445652	18-7160	18-7115	18-7153	-
40 4cil	C159200	G053313	18-7160	18-7115	18-7153	-
40 2cil	G055314	SUP	-	-	18-7155 ②	-
45	1476510	1531568	18-7160	18-7155	18-7153	-
45 4cil	5531630	SUP	18-7160	18-7115	18-7153	-
50	1421113	1639472	18-7152	18-7155	18-7153	-
50	1639473	1770178	18-7160	18-7155	18-7153	-
50	1770179	2305100	18-7160	18-7155	18-7153	-
50	2305101	2858813	18-7160	18-7155	18-7153	-
50	2858814	4140999	18-7160	18-7155	18-7153	-
50	4141000	4962055	18-7160	18-7155	18-7153	-
50	4962056	5531630	18-7160	18-7155	18-7153	-
50 3cil	6428681	D000750	18-7160	18-7155	18-7153	-
50/55/60 3 cil	D000751	SUP	-	18-7173	-	-
60	1303411	1542744	-	18-7115	-	-
60	6428681	D000750	18-7160	18-7155	18-7153	-
65	1542745	2874263	18-7157	18-7173	18-7153	18-7158
65	2874263	3293183	18-7157	18-7162	18-7153	18-7158
65 3cil	3293184	4136684	18-7160	18-7155	18-7153	-
65 3cil	4136685	4571651	18-7160	18-7155	18-7153	-
70	1296411	1413610	18-7114	18-7155 ①	-	-
70	1413611	1566239	18-7157	18-7173	18-7153	18-7158
70 3cil	4571652	4977156	18-7160	18-7155	18-7153	-
70 3cil	4977157	5579016	18-7160	18-7115	18-7153	-
70 3cil	5579017	A996142	18-7160	18-7115	18-7153	-
70/75 3cil	A996142	SUP	-	-	18-7198	-
75 4cil	6432901	A996142	18-7157	18-7162	18-7153	-
80	1335465	1398629	18-7157	18-7155	18-7153	18-7158
80	1398630	1566239	18-7157	18-7173	18-7153	18-7158
80 4cil	2559001	3144218	18-7157	18-7173	18-7153	18-7158
80 4cil	3144219	4831998	18-7157	18-7162	18-7153	-
80 4cil	4831999	5582561	18-7157	18-7162	18-7153	-
80 4cil	5582562	A996142	18-7157	18-7162	18-7153	-
80 3cil	A996142	SUP	-	-	18-7198	-
85	1460999	1766823	18-7157	18-7173	18-7153	18-7158
85 4cil	3493913	4590511	18-7157	18-7162	18-7153	-

① Requiere 2

② Retenedor Eje cambio

④ Se adapta a la mayoría de aplicaciones

APLICACIÓN AROS UNIDAD INFERIOR (Cont.)

HP	Desde N° Serie.	Hasta N° Serie.	Aro tórico Cojinete	Base bomba de agua	Cambio Eje	Eje Dirección
85 4cil	4590512	4831998	18-7157	18-7162	18-7153	-
90	1766824	1869775	18-7157	18-7162	18-7153	18-7158
90	4845301	5594656	18-7157	18-7162	18-7153	-
90	5594657	A996142	18-7157	18-7162	18-7153	-
90 3cil	A996142	SUP	-	-	18-7198	-
95	1869776	2318585	18-7157	18-7173	18-7153	18-7158
100,100SS	1464949	2836018	18-7157	18-7173	18-7153	18-7158
100BP	2399698	2641854	18-7157	18-7173	18-7153	18-7158
100 4cil	B209468		-	-	18-7198	-
110	1870204	2314955	18-7157	18-7173	18-7153	18-7158
115	2836019	3525440	18-7157	18-7173	18-7153	18-7158
115	3525440	41122634	18-7157	18-7173	18-7153	-
115	41122635	4855152	18-7157	18-7162	18-7153	-
115	4855153	5600966	18-7157	18-7162	18-7153	-
115	5600967	C100000	18-7157	18-7162	18-7153	-
115 4cil	C100000	SUP	-	-	18-7198	-
125	2314956	2839368	18-7157	18-7173	18-7153	18-7158
135	2839369	3293233	18-7157	18-7173	18-7153	18-7158
140	3293234	3502805	18-7157	18-7173	18-7153	-
140	4865678	SUP	18-7157	18-7162	18-7153	-
150	3502806	4121434	18-7157	18-7173	18-7153	-
150	4121434	5327662	18-7157 ④	18-7162	18-7153	-



V-6

150/150XR2	4868998	5432021	18-7159	18-7162	18-7153	-
150/150XRS	5432021	A904646	18-7159	18-7176	18-7153	-
135/150/XR2	A904646	SUP	18-7159	18-7176	18-7153	-
175	4301235	6618750	18-7159	18-7162	18-7153	-
175	6618751	SUP	18-7159	18-7176	18-7153	-
200	4839034	6073191	18-7159	18-7162	18-7153	-
200	6073192	SUP	18-7159	18-7176	18-7153	-
220	B117316	SUP	18-7159	18-7176	18-7153	-
225	5628028	D280813	18-7159	18-7162	18-7153	-
250/275	C101891	SUP	18-7159	-	18-7153	-
3.4	5611648	SUP	18-7159	-	18-7153	-

APLICACIÓN AROS CON ABRAZADERA GIRATORIA

HP	Desde N° Serie.	Hasta N° Serie.	Aros	Cant.	Desc.	HP	Desde N° Serie.	Hasta N° Serie.	Aros	Cant.	Desc.
3.9	1655013	2498135	18-7153	2	SB	V 135	A904646	SUP	18-7164	1	SB
4	2498136	3529445	18-7153	1	SB	V 135	A904646	SUP	18-7174	1	TT
6	1436115	2529894	18-7153	2	SB	V 150	4868998	SUP	18-7164	1	SB
7.5	2529895	3488152	18-7153	2	SB	V 150	5432022	6606990	18-7168	2	TLL
9.9	1470349	3482752	18-7153	2	SB	V 150	6443213	SUP	18-7174	1	TT
35 ①	B110789	C159199	18-7164	1	SB,U	V 175	4301235	SUP	18-7164	1	SB
35 ①	B110789	C159199	18-7174	1	TT	V 175	5488752	6618750	18-7168	2	TLL
45 4 Cil ①	B110789	SUP	18-7174	1	TT	V 175	6618751	SUP	18-7174	1	TT
45 4 Cil ①	B110789	SUP	18-7164	1	SB,U	V 200	4839034	SUP	18-7164	1	SB
50 3 Cil ①	B122930	C160935	18-7164	1	SB,U	V 200	5464486	6625220	18-7168	2	TLL
50 3 Cil ①	B122930	C160935	18-7174	1	TT	V 200	6625221	SUP	18-7174	1	TT
60 3 Cil ①	B122930	C160935	18-7174	1	TT	V 200 EFI	C100861	SUP	18-7174	1	TT
60 3 Cil ①	B122930	C160935	18-7164	1	SB,U	V 200 EFI	C100861	SUP	18-7164	1	SB
70	A996142	SUP	18-7174	2	TT	V 220	B117316	SUP	18-7174	1	TT
70	A996142	SUP	18-7164	1	SB	V 220	B117316	SUP	18-7164	1	SB
75	6432901	SUP	18-7174	2	TT	V 225	5628028	SUP	18-7164	1	SB
75	6432901	SUP	18-7164	1	SB	V 225	5628028	SUP	18-7168	2	TLL
80	A996142	SUP	18-7164	1	SB	V 250	C101891	SUP	18-7168	2	TLL
80	A996142	SUP	18-7174	2	TT	V 250	C101891	SUP	18-7174	1	TT
90	6436123	SUP	18-7164	1	SB	V 275	C101891	SUP	18-7174	1	TT
90	6436123	SUP	18-7174	2	TT	V 275	C101891	SUP	18-7168	2	TLL
100	B209468	SUP	18-7164	1	SB	3.4 LT	5611648	SUP	18-7168	2	TLL
100	B209468	SUP	18-7174	1	TT	3.4 LT	5611648	SUP	18-7174	1	TT
100	B209468	SUP	18-7174	1	TT	3.4 LT	5611648	SUP	18-7164	1	SB
115	6436123	SUP	18-7164	1	SB	XR-4/Magnum II	B242885	SUP	18-7174	1	TT
115	6436123	SUP	18-7174	2	TT	XR-4/Magnum II	B242885	SUP	18-7164	1	SB

① Modelos solo con power trim SB Abraz giratoria SB,U Abraz. giratoria sup. TLL Palanca Tilt TT Tubo Tilt

2 TIEMPOS MARINER 				2 TIEMPOS MARINER 			
MARINER	AÑO	Ref. CHAMPION	Ref. PRONAUTIC	MARINER	AÑO	Ref. CHAMPION	Ref. PRONAUTIC
2 TIEMPOS				15HP651		RL82C/L82C	050924/050937
2HP	1993-94	L86CC/L86C	050953/050910	15HP684-669		RL82C/L82C	050924/050937
2.5HP 1 CIL.	1989-97	L86CC/L86C	050953/050910	15HP Marathon	1992+	L92LCC	051020
2.5HP	1998+	QL87YC/L87C	050920/	20HP	1985+	QL78YC/L78YC	050917/050933
3HP	1990-92	L86CC/L86C	050953/050910	20HP 653,6A9		RL86C/L86C	050925/050910
3.3HP	1993-97	L86CC/L86C	050953/050910	20HP Hign-Ing		RA8HC	050957
3.5HP	1993-94	L86CC/L86C	050953/050910	25HP		QL78YC/L78YC	050917/050933
4HP	1990-97	RL82C/L82C	050924/050937	25HP 648,690,695		QL77JC4/L77JC4	050914/050906
5HP 1 CIL.	1990+	RL82C/L82C	050924/050937	25HPMar.25 648	1993-96	QL77JC4/L77JC4	050914/050906
5HP 5B-5C	1990-97	RL82C/L82C	050924/050937	25HP 2C. Mar.25	1993+	QL78YC/L78YC	050917/050933
6HP 6C-6HB	1993-96	RL82C/L82C	050924/050937	28HP 664		RL82C/L82C	050924/050937
6HP 2 CIL.	1992-97	QL78YC/L78YC	050917/050933	30HP 30A 689,A	1992-97	RL82C/L82C	050924/050937
6HP 6B(678)	1993-96	RL82C/L82C	050924/050937	30HP Marathon		QL78YC/L78YC	050917/050933
6HP 6C(6H8)	1993-96	RL82C/L82C	050924/050937	40HP	1989-98	QL78YC/L78YC	050917/050933
6HP	2000+	L92LCC	051020	40HP 4 CIL.	1989-97	QL78V/L78V	050916/050908
8HP K8-8A	1991-95	RL82C/L82C	050924/050937	40HP 6F5-6F6	1992-96	QL78C/L78C	050915/050907
8HP 6 CIL.	1991-95	RL82C/L82C	050924/050937	40HP A-B		QL78C/L78C	050915/050907
8HP B-W8	1991-95	RL82C/L82C	050924/050937	40HP 6E9	1992-96	QL78C/L78C	050915/050907
8HP 2 CIL.	1987-97	QL78YC/L78YC	050917/050933	40HP 676B	1992-96	QL78C/L78C	050915/050907
8HP 2 CIL.	1998+	L92LCC	051020	45HP	1986-89	QL78V/L78V	050916/050908
8HP Marathon	1991-95	RL82C/L82C	050924/050937	48HP		L82CC	051021
9.9HP(682)		RL82C/L82C	050924/050937	50HP	1980-98	QL78V/L78V	050916/050908
9.9HP 2 CIL.	1995-97	QL78YC6/ L78YC6	050962/050923	55HP		QL78C/L78C	050915/050907
9.9HP 2 CIL.	1998+	L92LCC	051020	55HPMar.	1991+	QL78YC/L78YC	050917/050933
9.9HP	1987-94	QL78YC/L78YC	050917/050933	60HP 3 CIL.	1991-98	QL78YC/L78YC	050917/050933
10HP Marathon	1991+	QL78YC6/ L78YC6	050962/050923	60HP 3 CIL.	1984-90	QL76V/L76V	050913/050905
15HP 2 CIL.		L92LCC	051020	60HP 2 CIL.		QL78C/L78C	050915/050907
15HP 2 CIL.	1989-97	QL78YC6/ L78YC6	050962/050923	70HP		QL78V/L78V	050916/050908



2 TIEMPOS MARINER







4 TIEMPOS MARINER







MARINER	AÑO	Ref. CHAMPION	Ref. PRONAUTIC	MARINER	AÑO	Ref. CHAMPION	Ref. PRONAUTIC
75HP		QL78V/L78V	050916/050908	4 TIEMPOS			
85HP		QL78V/L78V	050916/050908	F4	2000-2004	RA8HC	050957
90HP 6 CIL		QL76V/L76V	050913/050905	F5	2000-2004	RA8HC	050957
90HP 4 CIL		QL78V/L78V	050916/050908	F6	2000-2004	RA8HC	050957
90HP3 CIL		QL78V/L78V	050916/050908	F9.9	2000-2004	RA8HC	050957
100HP		QL78YC/L78YC	050917/050933	F9.9 Sail power	1995-2004	Z9Y	051014
105HP	1995-97	QL6VC/L6VC	050912/050934	F15 Big foot	1998-2004	RA8HC	050957
115HP 4 CIL		QL78YC/L78YC	050917/050933	F25 Big foot	1997-2004	RA8HC	050957
115HP 6CIL		QL76V/L76V	050913/050905	F30	1999-2004	RA8HC	050957
125HP	1994+	QL78YC/L78YC	050917/050933	F40 Big foot	1998-2004	RA8HC	050957
135HPV6 Ma.		QL6VC/L6VC	050912/050934	F50 Big foot	1995-2004	RA8HC	050957
135HP V6		QL78YC/L78YC	050917/050933	F60	2001-2004	RA8HC	050957
140HP 6 CIL		QL76V/L76V	050913/050905	F75DOHL	2000-2004	10YC4	050984
150HP V6EFI	1991-97	QL76VC/L76VC	050913/050905	75EFI		14PYC	050984
150HP DFI		R10ECC	051022	80EFI		14PYC	050984
175HP		QL6VC/L6VC	050912/050934	90DOHL	2000-2004	10YC4	050984
200HP		QL6VC/L6VC	050912/050934	90EFI		14PYC	051024
200HP EFI		QL78YC/L78YC	050917/050933	100EFI		14PYC	051024
220HP V6 3.0DFI		R10ECC	051022	115DOHL	2000-2004	10YC4	050984
220HPMagV220		RQL6VC/L6VC	050913	115EFI		14PYC	051024
225HP		QL77CC	050989	OPTIMAX Todos		QC12GMC	051025
250HP 6CIL 3.4L		RQL6VC/L6VC	050913/050934				
250HP V6		QL77CC	050989				
260HP		QL6VC/L6VC	050912/050934				
265HP		QL6VC/L6VC	050912/050934				
275HP		QL6VC/L6VC	050912/050934				

2 TIEMPOS MERCURY 				2 TIEMPOS MERCURY 			
MERCURY	AÑO	Ref. CHAMPION	Ref. PRONAUTIC	MERCURY	AÑO	Ref. CHAMPION	Ref. PRONAUTIC
2 TIEMPOS				15 HP Sea Pro	1995-97	QL78YC6/ L78YC6	050962/050923
2'5HP	1993-04	QL87YC/L87YC	050920/050938	15 HP 2 CIL.	1989-97	QL78YC6/ L78YC6	050962/050923
3 HP	1990-92	RL82YC/L82YC	050952/050909	15 HP 2 CIL.Sea	1998 +	L92LCC	O51020
3'3 HP	1993-97	RL82YC/L82YC	050952/050909	18 HP	1980-85	QL77JC4/L77JC4	050914/050906
3'3 HP	1998 +	RL87YC/L87YC	050963/050938	20 HP 2 CIL.	1998 +	QL78V/L78V	050916/O50908
3'5 HP	1983-85	RL82YC/L82YC	050952/050909	20 HP 2 CIL.	1986-97	QL78YC/L78YC	050917/050933
4 HP	1986-87	RL78V/L78V	000000/050908	25 HP 2 CIL.Sea	1993-97	QL78YC/L78YC	050917/050933
4 HP	1980-82	RL82YC/L82YC	050952/050909	25 HP 2 CIL.	1980-98	QL78YC/L78YC	050917/050933
4 HP	1988-97	RL82YC/L82YC	050952/050909	30 HP 2 CIL.Sea	1995-98	QL78YC/L78YC	050917/050933
4 HP 1 CIL.	1988	QL82YC/L82YC	050918/050909	30 HP 2 CIL.	1995 +	QL78YC/L78YC	050917/050933
4'5 HP	1977-85	QL78V/L78V	050916/050908	35 HP	1984-91	QL76V/L76V	050913/050905
5 HP	1988-97	RL82YC/L82YC	050952/050909	40 HP	1970-83	QL76V/L76V	050913/050905
5 HP 1 CIL.	98 +	RL82YC/L82YC	050952/050909	40 HP	1988-98	QL78YC/L78YC	050917/050933
6 HP 2 CIL.	98 +	L92LCC	O51020	45 HP	1986-89	QL78YC/L78YC	050917/050933
6 HP	1986-97	QL78YC/L78YC	050917/050933	50 HP	1970-90	QL76V/L76V	050913/050905
7'5 HP	1970-78	QL78V/L78V	050916/050908	50 HP 3 CIL.	1991-98	QL78YC/L78YC	050917/050933
7'5 HP	1979-85	QL77JC4/L77JC4	050914/050906	55 HP Sea Pro	1992-98	QL78YC/L78YC	050917/050933
8 HP	1986-97	QL78YC/L78YC	050917/050933	60 HP	1980-84	QL76V/L76V	050913/050905
8 HP	1998 +	L92LCC	O51020	60 HP 3 CIL.	1991-98	QL78YC/L78YC	050917/050933
9'8 HP	1970-78	QL78V/L78V	050916/050908	65 HP	1970-76	QL76V/L76V	050913/050905
9'8 HP	1979-85	QL77JC4/L77JC4	050914/050906	70 HP	1977-83	QL76V/L76V	050913/050905
9'9 HP 2 CIL.	1995-97	L78YC6	O50923	70 HP	1987-89	QL78V/L78V	050916/050908
9'9 HP 2 CIL.	1998	L92LCC	O51020	75 HP	1984-98	QL78V/L78V	050916/050908
9'9 HP	1986-94	QL78YC/L78YC	050917/050933	80 HP	1978-89	QL78V/L78V	050916/050908
10 HP sea Pro	1991-97	QL78YC6/ L78YC6	050962/050923	90 HP 6 CIL.	1978-86	QL76V/L76V	050913/050905
10 HP	1991-96	QL78YC6/ L78YC6	050962/050923	90 HP 3CIL.	1987-98	QL78V/L78V	050916/050908
15 HP 2 CIL.	1998 +	L92LCC	O51020	100 HP	1988-96	QL78YC/L78YC	050917/050933

2 TIEMPOS MERCURY 							
MERCURY	AÑO	Ref. CHAMPION	Ref. PRONAUTIC				
				280 HP	1997+	QL6VC/L6VC	050912/050934
				300 HP 2.5L EFI	1997+	QL6VC/L6VC	050912/050934
115 HP 6 CIL.	1970-88	QL76V/L76V	050913/050905	300 HP	1980-83	QL76VC/L76VC	051017/051018
				4 TIEMPOS MERCURY 			
MERCURY	AÑO	Ref. CHAMPION	Ref. PRONAUTIC				
				4 TIEMPOS			
				F4	2000-2004	RA8HC	O50957
				F5	2000-2004	RA8HC	O50957
				F6	2000-2004	RA8HC	O50957
				F9.9	2000-2004	RA8HC	O50957
				F9.9 Sail Power	1995-2004	Z9Y	O51014
				F15 Big Foot	1998-2004	RA8HC	O50957
				F25 Big Foot	1997-2004	RA8HC	O50957
				F30	1999-2004	RA8HC	O50957
				F40 Big Foot	1998-2004	RA8HC	O50957
				F50 Big Foot	1995-2004	RA8HC	O50957
				F60	2001-2004	RA8HC	O50957
				F75DOHL	2000-2004	REC10YC4	O51016
				75 EFI		REC14PYC	O51024
				80 EFI		REC14PYC	O51024
				90 DOHL	2000-2004	REC10YC4	O51016
				90 EFI		REC14PYC	O51024
				100 EFI		REC14PYC	O51024
				115 DOHL	2000-2004	REC10YC4	O51016
				115 EFI		REC14PYC	O51024
				OPTIMAX todos		QC12GMC	O51025
115 HP 6 CIL.	1970-88	QL76V/L76V	050913/050905				
115 HP 4 CIL.	1989-98	QL78YC/L78YC	050917/050933				
125 HP	1994-98	QL78YC/L78YC	050917/050933				
135 HP 6 CIL.	1986-97	QL6VC/L6VC	050912/050934				
135 HP V6	2000 +	QL82YC/L82YC	050918/050909				
140 HP	1970-80	QL6VC/L6VC	050912/050934				
150 HP V6	1978-97	QL6VC/L6VC	050912/050934				
150 HP V6 EFI	2000 +	QL82YC/L82YC	050918/050909				
150 V6 XR2-4-6	1985-97	QL6VC/L6VC	050912/050934				
150 HP V6 XR1	1993-97	QL6VC/L6VC	050912/050934				
175 HP V6 Xri	1997-97	QL6VC/L6VC	050912/050934				
175 HP V6 XriEFI	2000+	QL82YC/L82YC	050918/050909				
200 HP V6	1978-97	QL6VC/L6VC	050912/050934				
200 HP V6	2000+	QL82YC/L82YC	050918/050909				
200 HP V6 Xri	1989-97	QL6VC/L6VC	050912/050934				
200 HP V6 XriEFI	2000+	QL82YC/L82YC	050918/050909				
200 HP 2.0LXR 2EFI	1997+	QL76V/L76V	050913/050905				
225 HP V6 XriEFI	1995-97	QL77CC	O50989				
225 HP V6 3.0L	1995-97	QL78YC/L78YC	O50917/050933				
225 HP V6 3.0L	1998+	QL77CC	O50989				
225 HP V6	1994-97	QL78YC/L78YC	O50917/050933				
225 HP V6	1998+	QL77CC	O50989				
245 HP 2.5L	1995-96	QL6VC/L6VC	050912/050934				
250 HP 3.4L	1989-90	QL6VC/L6VC	050912/050934				
250 HP V6 XriEFI	1995-98	QL77CC	O50989				
265 HP	1997+	QL6VC/L6VC	050912/050934				
275 HP	1984-94	QL6VC/L6VC	050912/050934				

MERCURY / MARINER 				MERCURY / MARINER 			
POTENCIA HP	AÑO	Ref. NGK	Ref. PRONAUTIC	POTENCIA HP	AÑO	Ref. NGK	Ref. PRONAUTIC
2,2	1989-1984	BPR6HS-10	050741	10, 2T Sea Pro	2001	BPZ8HS-15	050863
2,5	2001-1993	BPR6HS	050827	10, 2T Sea Pro	2000-1991	BP8HS-15	050869
3	1992-1990	B6HS	050804	10 XR10	1998-1992	BP8HS-15	050869
3,3	2001-1993	BPR6HS	050827	15, 2T	2000-1989	BP8HS-15	050869
3,5	1985-1983	BP6HS-10	050820	15, 2T	2001	BPZ8HS-15	050863
3,6	1982-1980	BP7HS-W	050822	15, 4T	2003-1998	DPR6EA-9	050865
4.0, 2T	2001-1988	BPR7HS	050829	15, 2T 15 Sea Pro	2001	BPZ8HS-15	050863
4.0, 4T	2003-2000	DCPR7E	050894	15, 2T 15 Sea Pro	2000-1997	BP8HS-15	050869
4.0.	1982-1980	BP7HS	050822	15, 15 Sea Pro	1996-1995	BP8HS-10	050729
4.0, 40 Gnat	1979-1976	BR6HS	050714	18	1983-1981	BP8H-N-10	050871
4,5	1985-1975	BUHW-2	050840	18 XD	1985-1984	BP8H-N-10	050871
5.0, 2T	2001-1988	BPR7HS	050829	20, 2T 20	2000-1986	BP8H-N-10	050871
5.0, 4T	2003-2001	DCPR7E	050894	20, 2T 20	2001	BPZ8H-N-10	050870
6.0, 2T	2001	BPZ8H-N-10	050870	20	1980-1979	BUHW-2	050840
6.0, 2T	2000-1986	BP8HN-10	050871	20, 2T 25	2001	BPZ8H-N-10	050870
6.0, 4T	2003-2000	DCPR7E	050894	20, 200	1978-1970	BUHW-2	050840
7,5	1985-1979	B9HS-10	050813	20, 2T 20 Jet	2000-1995	BP8H-N-10	050871
7,5	1978-1975	BUHW-2	050840	20, 2T 20 Jet	2001	BPZ8H-N-10	050870
8.0, 2T	2001	BPZ8H-N-10	050870	20, 2T 25 Sea Pro	2001	BPZ8H-N-10	050870
8.0, 2T	2000-1986	BP8HN-10	050871	25, 2T	2000-1993	BP8H-N-10	050871
8.0 Bondensee	1999-1995	CR6HS	050845	25, 4T	2003-1998	DPR6EA-9	050865
9,8	1985-1979	B9HS-10	050813	25	1992-1986	BP8H-N-10	050871
9,8, 110	1978-1975	BUHW-2	050840	25	1983-1990	BP8H-N-10	050871
9.9, 2T	2001	BPZ8HS-15	050863	25, 2T 25 Sea Pro	2000-1993	BP8H-N-10	050871
9.9, 2T	2000-1995	BP8HS-15	050869	25 XD	1986-1984	BP8H-N-10	050871
9.9, 4T	1998-1995	CR6HS	050845	30, 2 CIL, 2T	2001	BPZ8H-N-10	050870
9.9, 4T	1994-1986	BP8H-N-10	050871	30, 2 CIL, 2T	2000-1995	BP8H-N-10	050871
9.9, 4T	2003-1999	DPR6EA-9	050865	30, 2 CIL, 4T	2003-1999	DPR6EA-9	050865
10	1991	BP8HS-15	050869				

MERCURY / MARINER 				MERCURY / MARINER 			
POTENCIA HP	AÑO	Ref. NGK	Ref. PRONAUTIC	POTENCIA HP	AÑO	Ref. NGK	Ref. PRONAUTIC
30, 3 CIL	1997-1995	BUHW-2	050840	55, 3 CIL., 2T 55 Sea Pro	2001	BPZ8H-N-10	050870
30, 3 CIL, 2T	2001	BPZ8H-N-10	050870	55, 3 CIL., 2T 55 Sea Pro	2000-1992	BP8H-N-10	050871
30, 2CIL, 2T, 30 Jet	2001	BPZ8H-N-10	050870	60, 3 CIL., 2T	2001	BPZ8H-N-10	050870
30, 3CIL, 2T, 30 Jet	2000-1998	BP8H-N-10	050871	60, 3 CIL., 2T	2000-1991	BP8H-N-10	050871
30, 2CIL, 2T, 30 Sea Pro	2001	BPZ8H-N-10	050870	60, 4 CIL., 4T	2003-2001	DPR6EA-9	050865
30, 2CIL, 2T, 30 Sea Pro	2000-1995	BP8H-N-10	050871	60	1990-1984	BUHW	050839
35	1991-1984	BUHW-2	050840	60 Big Foot	1997-1995	BP8H-N-10	050871
40, 2 CIL., 2T	2001	BPZ8H-N-10	050870	60, 3 CIL., 2T Sea Pro	2001	BPZ8H-N-10	050870
40, 2 CIL., 2T	2000-1995	BP8H-N-10	050871	60, 3 CIL., 2T Sea Pro	2000-1995	BP8H-N-10	050871
40, 3 CIL., 2T	2001	BPZ8H-N-10	050870	65, 3 CIL., 2T Jet	2001	BUZHW-2	050703
40, 3 CIL., 2T	2000-1998	BP8H-N-10	050871	65, 3 CIL., 2T Jet	2000-1995	BUZHW-2	050703
40, 3 CIL., 4T	2003-1998	DCPR7E	050894	65, 650	1976-1972	BUHW	050839
40, 4 CIL.	1997-1988	BUHW-2	050840	70	1989-1987	BUHW-2	050840
40, 400	1971-1970	BUHW	050839	70	1983-1979	BUHW	050839
40, 402	1978-1972	BUHW	050839	70, 700	1978-1977	BUHW	050839
40, 4 CIL., 4T, Big Foot	2003-2001	DPR6EA-9	050865	75, 3 CIL., 2T	2001	BUZHW-2	050703
40, 4 CIL., 2T, Sea Pro	2001	BPZ8H-N-10	050870	75, 3 CIL., 2T	2000-1987	BUHW-2	050840
40, 4 CIL., 2T, Sea Pro	2000-1995	BP8H-N-10	050871	75, 4 CIL., 4T DOHC 75	2003-2000	LF5A-11	050862
45	1989-1986	BUHW-2	050840	75, 3 CIL., 2T Jet	2001	BUZHW-2	050703
45, 4 CIL., 4T, Bordensee	2001-1995	DPR6EA-9	050865	75, 3 CIL., 2T Sea Pro	2000-1991	BUHW-2	050840
45, 3 CIL., 2T Jet	2001	BPZ8H-N-10	050870	75, 4 CIL., 75XD	1986-1984	BUHW-2	050840
45, 3 CIL., 2T Jet	2000-1995	BP8H-N-10	050871	80, 3 CIL.	1989-1987	BUHW-2	050840
50, 3 CIL.	1990-1986	BUHW	050839	80, 4 CIL.	1983-1979	BUHW-2	050840
50, 3 CIL. 2T	2001	BPZ8H-N-10	050870	80, 800	1978	BUHW-2	050840
50, 3 CIL. 2T	2000-1991	BP8H-N-10	050871	80, 4 CIL., 2T 80 Jet	2001	BPZ8H-N-10	050870
50, 4 CIL.	1985-1979	BUHW-2	050840	80, 4 CIL., 2T 80 Jet	2000-1995	BP8H-N-10	050871
50, 4 CIL. 4T	2003-1995	DPR6EA-9	050865	85	1977-1973	BUHW	050839
50, 500	1977-1968	BUHW	050839	90, 3 CIL., 2T	2001	BUZHW-2	050703
50, 500	1978	BUHW-2	050840	90, 4 CIL., 4 T DOHC	2003-2000	LF5A-11	050862

MERCURY / MARINER 				MERCURY / MARINER 			
POTENCIA HP	AÑO	Ref. NGK	Ref. PRONAUTIC	POTENCIA HP	AÑO	Ref. NGK	Ref. PRONAUTIC
90, 6 CIL.	1986-1979	BUHW	050839	150, 6 CIL., 2T Optimax DFI	2002-1998	PZFR5F-11	050846
90	2000-1987	BUHW-2	050840	150XR-2	1987-1985	BU8H	050838
90, 900	1978	BUHW	050839	150XR-4	1991-1988	BU8H	050838
100	1999-1988	BP8H-N-10	050871	150XR-6	1997-1992	BU8H	050838
105 Jet	1998-1995	BU8H	050838	150XRi	1997-1993	BU8H	050838
115, 4 CIL., 2T	2001	BPZ8H-N-10	050870	150, 1500	1977-1973	BUHW	050839
115, 4 CIL., 2T	2000-1989	BP8H-N-10	050871	150, 6 CIL. 4T EFI	2006	ILFR6G	050722
115, 6 CIL.	1988-1979	BUHW	050839	175	1998-1979	BU8H	050838
115, 4 CIL., 4T, EFI MFI	2003-2001	LFR5A-11	050862	175, 1750	1978-1976	BUHW	050839
115, 6 CIL., 2T Optimax	2000	PZFR5F-11	050846	175 EFI	1999-1998	BU8H	050838
115	1978-1970	BUHW	050839	175, 6 CIL. 2T EFI MFI	2001-2000	BPZ8HS-10	050842
125, 4 CIL. 2T	2001	BPZ8H-N-10	050870	175, 6 CIL. 2T Optimax DFI	2002-2001	PZFR5F-11	050846
125, 4 CIL. 2T	2000-1994	BP8H-N-10	050871	175 XRI	1997-1991	BU8H	050838
135, 6 CIL, 2T	2000	BPZ8HS-N-10	050870	175, 6 CIL. 4T EFI	2006	ILFR6G	050722
135	1999-1986	BU8H	050838	200, 6 CIL., 2T	2001-2000	BPZ8HS-10	050842
135, 6 CIL, 4T EFI	2006	ILFR6G	050722	200	1999-1979	BU8H	050838
135, 6 CIL, 2T Optimax DFI	2003	IZFR5G	050876	200, 6 CIL., 4T EFI	2006	ILFR6G	050722
135, 6 CIL, 2T Optimax DFI	2002-1998	PZFR5F-11	050846	200, 2.0L Duece High EFI	1997	BUZ8H	050735
140, 140	1980-1979	BUHW	050839	200, VERADO, 4T EFI	2004	ILFR6G	050722
140, 1400	1978-1972	BUHW	050839	200, 2.0L F1 EFI	1997	BUZHW	050736
140 Jet	1999-1995	BU8H	050838	200, 2.0L SST 120 EFI	1997	BUHW	050839
150	2000	BPZ8HS-N-10	050870	200, 2.0L XR2SS EFI	1997	BUHW	050839
150	1999-1991	BU8H	050838	200 DFI	1997	PZFR6H	050886
150, 150	1994-1979	BU8H	050838	200 EFI	1999-1998	BU8H	050838
150, 1500	1978	BU8H	050838	200, 6 CIL., 2T 200 EFI MFI	2001-2000	BPZ8HS-10	050842
150, 6 CIL., 2T EFI	2001-2000	BPZ8HS-N-10	050870	200, 6 CIL., 2T 200 Optimax	2003	IZFR5G	050876
150 EFI	1999-1998	BU8H	050838	200, 6 CIL., 2T 200 Optimax	2002-1998	ZFR5F-11	050846
150 Marathon	1988-1985	BU8H	050838	1200 Xri	1997-1989	BUZ8H	050735
150, 6 CIL., 2T Optimax DFI	2003	IZFR5G	050876	200, 2000	1978	BUHW	050839

MERCURY / MARINER

POTENCIA HP	AÑO	Ref. NGK	Ref. PRONAUTIC
220, V-220 Laser	1988-1987	BUZ8H	050735
225, 6 CIL., 2T	2001-1998	BR8HS	050854
225, VERADO, 4T EFI	2004	ILFR6G	050722
225	1997-1994	BPZ8H-N-10	050870
225, 4T EFI	2006	ILFR6G	050722
225	1981-1980	BU8H	050838
225, 6 CIL., 2T EFI DFI	2001-1995	BR8HS	050854
225 Xri EFI	1999-1995	BR8HS	050854
225, 6 CIL., 2T 3.0L Sea Pro	2001-1997	BR8HS	050854
225, 3.0L Work	1997-1994	BPZ8H-N-10	050870
225, 3.0L Work	1998	BR8HS	050854
245, 2.5L	1996-1995	BU8H	050838
250, 4T EFI	2006	ILFR6G	050722
250, 3.4L	1990-1989	BU8H	050838
225, VERADO, 4T EFI	2004	ILFR6G	050722
250, 6 CIL., 2T XRI EFI	2001-1995	BR8HS	050854
260, 2.5L Off-shore	1997-1995	BU8H	050838
265, 2.5L SS Drag EFI	1997	BU8H	050838
275, 4T EFI	2006	ILFR6G	050722
275	1994-1989	BU8H	050838
275, VERADO, 4 T EFI	2004	ILFR6G	050722
300	1983-1981	BU8H	050838
300, 2.5L, S3000 EFI	1997	BU8H	050838
300, 3.0L	2001	BU8H	050838
300, 3.4L	1998-1984	BU8H	050838

MERCURY / MARINER

Tipo	Modelo Fueraborda	Referencia-Diam./Paso	Ref. Original	Palas	Núcleo
M5	 <p>4 - 6 hp • 4hp (4 tiempos) 1999 y posteriores • 4hp (2 tiempos) 1987 y posteriores • 5hp (2 tiempos) 1987 y posteriores • 6hp (4 tiempos) 1999 y posteriores</p> <p>Escape a través del núcleo, 12 estrias</p>	62M57788 7 7/8x8	48-812950A02	3	Fijo
		62M159147 9 1/4x7	48-828152A12	3	Fijo
A	 <p>6 - 15 hp 2-1/2" Caja de engranajes • 6,8,9,9hp (2 tiempos) 1986-2005 • 8, 9,9hp (4 tiempos) 1995-2005 • 10hp 1995 y posteriores • 10,15hp (Sea Pro, Marathon) 1995-2001 • 15hp (2 tiempos) 1989-2005 • 15hp (4 tiempos) 1999-2006 • No para motores Bigfoot</p> <p>Escape a través del núcleo, 8 estrias</p>	62M1598 9x8	48-828154A12	3	
		62M1599 9x9	48-828156A12	3	
		9.9 - 20 hp 2-1/2" Caja de engranajes, 14 estrias • 9,9hp (Bigfoot) 2005-2013 • 9,9hp Command hasta 2016 y posteriores • 15, 20hp (4 tiempos) 2007 y posteriores	Utilice hélices de clase Tohatsu A		
B	 <p>9.9 - 25 hp 3" Caja de engranajes • 9,9hp (Bigfoot, 4 tiempos) 1999-2005 • 15hp (Bigfoot, 4 tiempos) 1999-2005 • 18hp Mercury 1980 - 1985 • 20hp (2 tiempos) Mercury 1986-2002 • 25hp (2 tiempos) Mercury 1980-2005 • 25hp (2 tiempos) Mariner 1985 y posteriores • 25hp (Sea Pro, Marathon) Todos los años</p> <p>Escape a través del núcleo, 10 estrias</p>	62M25103811 10 3/8x11	48-19638A40	3	Fijo
		62M25103813 10 3/8x13	48-19640A40	3	
	25 - 30 hp 3" Caja de engranajes, 10 estrias • 25, 30hp (4 tiempos, no Bigfoot) 2006 y posteriores	Utilice hélices de clase Tohatsu B.			
C	   <p>25 - 70 hp 3-1/4" Caja de engranajes • Modelo 402, 500, y 700 1977-1984 • 25hp (4 tiempos, Bigfoot) 1999-2005 • 30hp (2 tiempos) 1994-2002 • 30hp (4 tiempos) 1999-2005 • 30hp (Sea Pro, Marathon) 1994 y posteriores • 35hp 1984-1989 • 40hp (2 tiempos) 1977 y posteriores • 40hp (4 tiempos, No Bigfoot) 1997 y post. • 40hp (Sea Pro, Marathon) 1977 y posteriores • 45hp 1986-1989 • 48hp (Mariner) Todos los años • 50hp (2 tiempos) 1977 y posteriores • 50hp (4 tiempos, Not Bigfoot) 1995 y posteriores • 55hp 1995 y posteriores • 60hp (2 tiempos) 1978 y posteriores • 60hp (4 tiempos, Not Bigfoot) 2001 y post. • 70hp hasta 1983</p> <p>Escape a través del núcleo, 13 estrias</p>	62M5512149 12 1/4x9	48-87818A10	3	Fijo
		62M55121012 12x10 1/2	48-42740A10	3	
		62M55111410 11 1/4x10	48-73132A40	3	
		62M55107811 10 7/8x11	48-85623A40	3	
		62M40105812 10 5/8x12	48-73134A40	3	
		62M40103813 10 3/8x13	48-73136A40	3	
		62M40101213 10 1/2x13	48-816704A40	3	
		62M40101414 10 1/4x14	48-73138A40	3	
		62M40103814 10 3/8x14	48-816706A40	3	
		62M40101815 10 1/8x15	48-73140A45	3	
		62U4012149 12 1/4x9		3	
		62U40113410 11 3/4x10		3	
		62U40115811 11 5/8x11		3	
		62U40113812 11 3/8x12		3	
		62U40111813 11 1/8x13		3	
62U40111414 11 1/4x14		3			
624U40105812 10 5/8x12	48-8M8026625	4	Interc. 62BHMC		
624U40103813 10 3/8x13	48-8M8026630	4			
624U40101814 10 1/8x14	48-8M8026635	4			
624U40101815 10 1/8x15	48-8M8026640	4			

MERCURY / MARINER

Tipo	Modelo Fueraborda	Referencia-Diam./Paso	Ref. Original	Palas	Núcleo	
D	 <p>40 - 140 hp 4-1/4" Caja de engranajes</p> <ul style="list-style-type: none"> • 40, 50hp (4 tiempos, Bigfoot) Todos años • 40hp Sea Pro 4 tiempos 2016 y post. • 60hp (4 tiempos, Bigfoot) 1995 y post. • 60hp Sea Pro 4 tiempos 2016 y post. • 70hp 1987-1989 • 75hp (Sea Pro, Marathon) todos los años • 75hp (2 tiempos) 1984-2005 • 75hp (4 tiempos) 2001 y posteriores • 80hp 1978-1989 • 90hp (2 tiempos) 1978 y posteriores • 90hp (4 tiempos) 2001 y posteriores • 100hp 1988 y posteriores • 115hp 1978 y posteriores • 115hp (4 tiempos) 2001 y posteriores • 125hp 1994 y posteriores • 140hp 1978-1981 • 650 (4 cilindros) 1961-1970 • 650 (2 cilindros) hasta 1971 • 800, 850 (2 y 4 cilindros) 1972-1977 • 900 y 1500 hasta 1977 <p>Escape a través del núcleo, 15 estrias</p>	62U601410 14x10	48-854342A45	3	Interc. 62BHMD	
		62U901411 14x11	48-77338A45	3		
		62U901413 14x13	48-77340A45	3		
		62U60133415 13 3/4x15	48-77342A45	3		
		62U90131417 13 1/4x17	48-77344A45	3		
		62U901319 13x19	48-77346A45	3		
		62U90123421 12 3/4x21	48-77348A45	3		
		624U90137811 13 7/8x11	8M8026560	4		
		624U90137813 13 7/8x13	8M8026570	4		
		624U90133815 13 3/8x15	8M8026580	4		
		624U901317 13x17	8M8026590	4		
		624U90121219 12 1/2x19	8M8026600	4		
		62M601410 14x10	48-854342A45	3		Fijo
		62M901411 14x11	48-77338A45	3		
		62M901413 14x13	48-77340A45	3		
		62M60133415 13 3/4x15	48-77342A45	3		
		62M90131417 13 1/4x17	48-77344A45	3		
		62M901319 13x19	48-77346A45	3		
62M9013421 12 3/4x21	48-77348A45	3				
E	 <p>90 - 275hp 4-3/4" Caja de engranajes</p> <ul style="list-style-type: none"> • 90, 115hp Sea Pro • 90, 115hp Command hasta 2014 y posteriores • 135hp 1987 y posteriores • 150hp 1978 y posteriores • 175hp 1978 y posteriores • 200hp 1978 y posteriores • 220hp 1987-1988 • 225hp 1980 y posteriores • 225hp (Sea Pro, Marathon) todos los años • 250hp 1994 y posteriores • 275hp 1990-1994 • 3.4 L.1984-1986 <p>Para colas mercruiser: • Alpha I y Bravo y con caja engr. 4 3/4"</p> <p>Escape a través del núcleo, 15 estrias</p>	62U1501613 16x13	48-78114A45	3	Interc. 62BHME	
		62U150151415 15 1/4x15	48-78116A45	3		
		62U1501616 16x16	48-16440A45	3		
		62U1351517 15x17	48-832828A45	3		
		62U150141219 14 1/2x19	48-832830A45	3		
		62U150141421 14 1/4x21	48-832832A45	3		
		62U1501423 14x23	48-832834A45	3		
		624U1501516 15x16	48-834850A45	4		
		624U150141218 14 1/2x18	48-834852A45	4		
		624U1501420 14x20	48-834854A45	4		

Johnson/Evinrude Modelo identificación

FUERABORDAS 1999 Y NUEVOS

Estilo	HP	Función diseño	Long. eje.	Año
J = Johnson E = Evinrude	Example: 20 40 200	3 = 3-CIL (25 or 35 HP) 4 = Motor 4 tiempos B = Pintura azul C = Contra-Rotación con Trim & Tilt D = E-TEC E = Arranque eléctrico con dirección remota F = FICHT Inyección comb G = Pintura grafito J = Jet M = Modelo militar P = Power Trim y Tilt R = Arranque manual con dirección triller S = Tipo especial (Evinrude blanco) T = Tiller dirección TE = Tiller Electrico W = Modelo comercial	= 15" L = 20" Y = 22.5" X = 25" Z = 30"	I = 1 N = 2 T = 3 R = 4 O = 5 D = 6 U = 7 C = 8 E = 9 S = 0 EX: EE = 1999 SC = 2008

Ejemplo: E70PLEEA - Evinrude modelo, 70 HP, Power Trim&Tilt, 20", 1999 modelo

<p>①18-5001D </p>  <p>18-5001 KIT ENCENDIDO Reemplaza: 172525 — CONTIENE —</p> <table border="1"> <thead> <tr> <th>Ref #</th> <th>Desc.</th> <th>O.E.#</th> <th>Cant.</th> </tr> </thead> <tbody> <tr> <td>18-5200</td> <td>Condensador</td> <td>580256</td> <td>1</td> </tr> <tr> <td>18-5157</td> <td>Conjunto contacto</td> <td>580290</td> <td>2</td> </tr> </tbody> </table>	Ref #	Desc.	O.E.#	Cant.	18-5200	Condensador	580256	1	18-5157	Conjunto contacto	580290	2	<p>①18-5002D </p>  <p>18-5002 KIT ENCENDIDO Reemplaza: 172523 — CONTIENE —</p> <table border="1"> <thead> <tr> <th>Ref #</th> <th>Desc.</th> <th>O.E.#</th> <th>Cant.</th> </tr> </thead> <tbody> <tr> <td>18-5205</td> <td>Condensador</td> <td>581419</td> <td>2</td> </tr> <tr> <td>18-5156</td> <td>Conjunto contacto</td> <td>580148</td> <td>2</td> </tr> </tbody> </table>	Ref #	Desc.	O.E.#	Cant.	18-5205	Condensador	581419	2	18-5156	Conjunto contacto	580148	2	<p>①18-5003D </p>  <p>18-5003 KIT ENCENDIDO Reemplaza: 172806 — CONTIENE —</p> <table border="1"> <thead> <tr> <th>Ref #</th> <th>Desc.</th> <th>O.E.#</th> <th>Cant.</th> </tr> </thead> <tbody> <tr> <td>18-5205</td> <td>Condensador</td> <td>581419</td> <td>2</td> </tr> <tr> <td>18-5141</td> <td>Conjunto contacto</td> <td>581207</td> <td>2</td> </tr> </tbody> </table>	Ref #	Desc.	O.E.#	Cant.	18-5205	Condensador	581419	2	18-5141	Conjunto contacto	581207	2
Ref #	Desc.	O.E.#	Cant.																																			
18-5200	Condensador	580256	1																																			
18-5157	Conjunto contacto	580290	2																																			
Ref #	Desc.	O.E.#	Cant.																																			
18-5205	Condensador	581419	2																																			
18-5156	Conjunto contacto	580148	2																																			
Ref #	Desc.	O.E.#	Cant.																																			
18-5205	Condensador	581419	2																																			
18-5141	Conjunto contacto	581207	2																																			
<p>①18-5006D </p>  <p>18-5006 KIT ENCENDIDO Reemplaza: 172522 — CONTIENE —</p> <table border="1"> <thead> <tr> <th>Ref #</th> <th>Desc.</th> <th>O.E.#</th> <th>Cant.</th> </tr> </thead> <tbody> <tr> <td>18-5199</td> <td>Condensador</td> <td>580321</td> <td>2</td> </tr> <tr> <td>18-5156</td> <td>Conjunto contacto</td> <td>580148</td> <td>1</td> </tr> </tbody> </table>	Ref #	Desc.	O.E.#	Cant.	18-5199	Condensador	580321	2	18-5156	Conjunto contacto	580148	1	<p>①18-5011D </p>  <p>18-5011 KIT ENCENDIDO Reemplaza: 172521 — CONTIENE —</p> <table border="1"> <thead> <tr> <th>Ref #</th> <th>Desc.</th> <th>O.E.#</th> <th>Cant.</th> </tr> </thead> <tbody> <tr> <td>18-5199</td> <td>Condensador</td> <td>580321</td> <td>1</td> </tr> <tr> <td>18-5156</td> <td>Conjunto cont.</td> <td>580148</td> <td>1</td> </tr> </tbody> </table>	Ref #	Desc.	O.E.#	Cant.	18-5199	Condensador	580321	1	18-5156	Conjunto cont.	580148	1	 <p>18-5141 CONJUNTO CONTACTOS Reemplaza: 581207</p>												
Ref #	Desc.	O.E.#	Cant.																																			
18-5199	Condensador	580321	2																																			
18-5156	Conjunto contacto	580148	1																																			
Ref #	Desc.	O.E.#	Cant.																																			
18-5199	Condensador	580321	1																																			
18-5156	Conjunto cont.	580148	1																																			
 <p>18-5156 CONJUNTO CONTACTO Reemplaza: 580148</p>	 <p>18-5157 CONJUNTO CONTACTO Reemplaza: 580290</p>	 <p>CONDENSADOR 18-5199 Reemplaza: 580321 18-5205 Reemplaza: 581419</p>	 <p>18-5200 CONDENSADOR Reemplaza: 580256</p>																																			

APLICACIONES EN LA SIGUIENTE PÁGINA

① referencias acabadas en "D" envasadas - Referencia normal no envasada

JOHNSON/EVINRUDE APLICACIÓN KIT ENCENDIDO

HP	Año inicial	Año final	Conjunto contacto	Condensador	Kit encendido	HP	Año inicial	Año final	Conjunto contacto	Condensador	Kit encendido
1.2	1986	1990	18-5156	18-5199	18-5011	25	1969	1976	18-5156	18-5205	18-5002
1.5	1968	1970	18-5156	18-5199	18-5011	28	1962	1964	18-5156	18-5205	18-5002
2	1971	1985	18-5156	18-5199	18-5011	30	1956	1956	18-5156	18-5199	18-5006
3	1952	1968	18-5156	18-5199	18-5006	33	1965	1970	18-5156	18-5205	18-5002
3	1989	1990	18-5156	18-5199	18-5006	35	1958	1959	18-5156	18-5199	18-5006
4	1969	1976	18-5156	18-5199	18-5006	35	1976	1976	18-5141	18-5205	18-5003
4	1981	1988	18-5156	18-5199	18-5006	38	1968	1968	18-5156	18-5199	18-5006
5	1965	1968	18-5156	18-5199	18-5006	40	1960	1961	18-5156	18-5199	18-5006
5.5	1954	1964	18-5156	18-5199	18-5006	40	1962	1973	18-5156	18-5205	18-5002
6	1965	1976	18-5156	18-5199	18-5006	40	1974	1976	18-5141	18-5205	18-5003
7.5	1956	1958	18-5156	18-5199	18-5006	40 Comm	1981	1983	18-5141	18-5205	18-5003
9.5	1964	1973	18-5156	18-5199	18-5006	50	1958	1959	18-5157	18-5200	18-5001
10	1950	1963	18-5156	18-5199	18-5006	60	1964	1967	18-5157	18-5200	18-5001
9.9	1970	1970	18-5156	18-5199	18-5006	75	1961	1967	18-5157	18-5200	18-5001
9.9	1974	1976	18-5141	18-5205	18-5003	80	1966	1967	18-5157	18-5200	18-5001
15	1956	1956	18-5156	18-5199	18-5006	90	1964	1965	18-5157	18-5200	18-5001
15	1974	1976	18-5141	18-5205	18-5003	90	1968	1968	18-5157	18-5200	18-5001
18	1956	1961	18-5156	18-5199	18-5006	100	1966	1966	18-5157	18-5200	18-5001
18	1962	1973	18-5156	18-5205	18-5002						
20	1968	1973	18-5156	18-5205	18-5002						
25	1955	1955	18-5156	18-5199	18-5006						



18-5163
BOBINA ENCENDIDO
Reemplaza: 581130, 763809



18-5170
BOBINA ENCENDIDO
Reemplaza: 583740, 583298



18-5172
BOBINA ENCENDIDO
Reemplaza: 581786, 502881



①18-5176D



18-5176
KIT BOBINA ENCENDIDO
Reemplaza: 582106, 582330 582366, 583737, 584561



①18-5179D



18-5179
BOBINA ENCENDIDO
Reemplaza: 582508



①18-5181D



18-5181
BOBINA ENCENDIDO
Reemplaza: 582995, 584477



18-5192
BOBINA ENCENDIDO
Reemplaza: 581610, 582091, 502888



18-5194
BOBINA ENCENDIDO
Reemplaza: 582160, 584632, 502890, 581032



18-5196
BOBINA ENCENDIDO
Reemplaza: 581407, 502880



APLICACIÓN EMPIEZAN EN LA SIGUIENTE PÁGINA

① Referencias acaban en "D" envasadas - referencias normales no envasadas

JOHNSON/EVINRUDE APLICACIONES DE ENCENDIDO

HP	Año inic.	Año final	Bobina	cant.	HP	Año inic.	Año final	Bobina	cant.	HP	Año inic.	Año final	Bobina	cant.
2	1971	1973	18-5181	1	20	1966	1972	18-5181	2	60	1980	1984	18-5176	2
2	1975	1985	18-5181	1	20	1973	1973	18-5163	1	60	1985	1987	18-5179	3
2	1995	2001	18-5179	1	20	1985	1987	18-5179	2	60	1988	1988	18-5176	3
2.5	1987	1988	18-5170	1	20	1988	1988	18-5176	2	60	1989	2001	18-5179	3
3	1955	1968	18-5181	2	20	1989	1998	18-5179	2	65	1972	1973	18-5194	3
3	1989	1990	18-5181	2	25	1951	1953	18-5181	2	65	1984	1984	18-5176	3
3	1991	1997	18-5170	1	25	1955	1955	18-5181	2	65	1985	1988	18-5179	3
3	1998	2001	18-5179	1	25	1969	1972	18-5181	2	65	1989	1990	18-5176	3
3	2003	2005	18-5179	1	25	1973	1976	18-5163	1	65	1991	2001	18-5179	3
3.3	1995	1997	18-5179	1	25	1973	1976	18-5172	2	70	1974	1975	18-5194	3
4	1969	1976	18-5181	2	25	1977	1984	18-5176	2	70	1979	1984	18-5176	3
4	1977	1980	18-5176	2	25	1985	1987	18-5179	2	70	1985	1987	18-5179	3
4	1981	1988	18-5181	2	25	1988	1988	18-5176	2	70	1988	1988	18-5176	3
4	1986	1987	18-5179	2	25	1989	2005	18-5179	2	70	1989	2001	18-5179	3
4	1987	2001	18-5170	1	28	1962	1964	18-5181	2	75	1975	1975	18-5194	3
4	1988	1988	18-5176	2	28	1986	1996	18-5179	2	75	1979	1984	18-5176	3
4	1989	1996	18-5179	2	28	1995	1998	18-5170	1	75	1985	1987	18-5179	3
4.5	1980	1983	18-5176	2	30	1956	1956	18-5181	2	75	1988	1988	18-5176	3
5	1965	1968	18-5181	2	30	1984	1984	18-5176	2	75	2000	2001	18-5170	2
5	1996	1998	18-5170	1	30	1985	1987	18-5179	2	85	1969	1972	18-5193	1
5	1997	2001	18-5179	2	30	1988	1988	18-5176	2	85	1973	1975	18-5194	3
5.5	1954	1964	18-5181	2	30	1989	2005	18-5179	2	85	1976	1977	18-5192	4
6	1965	1976	18-5181	2	30	1999	2001	18-5170	1	85	1978	1980	18-5176	4
6	1977	1979	18-5176	2	33	1965	1970	18-5181	2	85	1991	1995	18-5179	4
6	1984	1984	18-5176	2	35	1957	1959	18-5181	2	88	1987	1987	18-5179	4
6	1985	1990	18-5179	2	35	1976	1976	18-5172	2	88	1988	1988	18-5176	4
6	1991	2005	18-5170	1	35	1977	1984	18-5176	2	88	1989	1996	18-5179	4
6	1997	2001	18-5179	2	35	1986	1987	18-5179	2	90	1981	1984	18-5176	4
6	2003	2004	18-5179	2	35	1988	1988	18-5176	2	90	1985	1987	18-5179	4
7.5	1954	1958	18-5181	2	35	1989	1994	18-5179	2	90	1988	1988	18-5176	4
7.5	1980	1983	18-5176	2	35	1996	1996	18-5179	2	90	1989	1998	18-5179	4
8	1984	1984	18-5176	2	40	1960	1973	18-5181	2	90	1995	2006	18-5170	2
8	1985	1990	18-5179	2	40	1974	1974	18-5196	2	100	1971	1972	18-5193	1
8	1991	2005	18-5170	1	40	1975	1979	18-5172	2	100	1979	1980	18-5176	4
9.5	1964	1973	18-5181	2	40	1983	1983	18-5172	2	100	1984	1984	18-5176	4
9.9	1974	1976	18-5196	2	40	1984	1984	18-5176	2	100	1985	1997	18-5179	4
9.9	1977	1984	18-5176	2	40	1985	1987	18-5179	2	100	1988	1988	18-5176	4
9.9	1985	1992	18-5179	2	40	1988	1988	18-5176	2	100	1998	2001	18-5170	2
9.9	1993	2001	18-5170	1	40	1989	2005	18-5170	1	105	1997	2001	18-5170	2
10	1949	1952	18-5181	2	40	1999	2001	18-5179	2	105	2003	2003	18-5170	2
10	1953	1953	18-5181	2	45	1986	1992	18-5179	2	110	1986	1987	18-5179	4
10	1954	1963	18-5181	2	45	1992	1997	18-5170	1	110	1988	1988	18-5176	4
10	2003	2007	18-5170	1	48	1987	1987	18-5179	2	110	1989	1989	18-5179	4
14	1988	1988	18-5179	2	48	1988	1988	18-5176	2	112	1994	1996	18-5179	4
14	1989	1989	18-5176	2	48	1989	1996	18-5170	1	115	1969	1970		1
15	1953	1953	18-5181	2	50	1971	1975	18-5194	2	115	1973	1975	18-5194	4
15	1955	1956	18-5181	2	50	1979	1984	18-5176	2	115	1976	1977	18-5192	4
15	1965	1968	18-5181	2	50	1985	1987	18-5179	2	115	1978	1984	18-5176	4
15	1974	1976	18-5196	2	50	1988	1988	18-5176	2	115	1985	1985	18-5179	4
15	1977	1984	18-5176	2	50	1989	2005	18-5170	1	115	1990	1998	18-5179	4
15	1985	1992	18-5179	2	50	1995	1998	18-5179	2	115	1995	2006	18-5170	2
15	1993	2007	18-5170	1	55	1978	1984	18-5176	2	120	1985	1987	18-5179	4
18	1957	1972	18-5181	2	55	1985	1992	18-5179	2	120	1988	1988	18-5176	4
18	1973	1973	18-5163	1	55	1992	2005	18-5170	1	120	1989	1994	18-5179	4

APLICACIONES CONTINUAN EN LA SIGUIENTE PÁGINA

Sistema encendido
JOHNSON / EVINRUDE (OMC/BRP)

JOHNSON/EVINRUDE APLICACIÓN BOBINA ENCENDIDO (Cont.)

HP	Año inic.	Año final	Bobina	cant.	HP	Año inic.	Año final	Bobina	cant.	HP	Año inic.	Año final	Bobina	cant.
125	1971	1972	18-5193	1	150	1985	1991	18-5179	6	185	1989	1990	18-5179	6
125	1989	1990	18-5179	4	150	1988	1988	18-5176	6	185	1992	1994	18-5179	6
125	1992	1998	18-5179	4	150	1991	2006	18-5170	3	200	1976	1978	18-5192	6
130	1995	2001	18-5179	4	155	1984	1984	18-5176	6	200	1979	1983	18-5176	6
135	1973	1975	18-5194	4	155	1985	1985	18-5179	6	200	1986	2001	18-5179	6
135	1976	1976	18-5192	4	155	1987	1987	18-5179	6	200	1999	1999	18-5170	3
135	2000	2001	18-5170	2	155	1988	1988	18-5176	6	225	1986	2001	18-5179	6
140	1977	1977	18-5192	4	155	1989	1992	18-5179	6	225	1999	1999	18-5170	3
140	1978	1984	18-5176	4	175	1977	1978	18-5192	6	235	1978	1978	18-5192	6
140	1985	1987	18-5179	4	175	1979	1983	18-5176	6	235	1979	1984	18-5176	6
140	1988	1988	18-5176	4	175	1985	1991	18-5179	6	235	1985	1985	18-5179	6
140	1989	1994	18-5179	4	175	1991	2006	18-5170	3	250	1991	2001	18-5179	6
150	1978	1978	18-5192	6	185	1984	1984	18-5176	6	275	1985	1988	18-5179	6
150	1979	1984	18-5176	6	185	1985	1985	18-5179	6	300	1985	1995	18-5179	6



18-5755
CAJA ENCENDIDO
Reemplaza: 581397, 764708
(pack 2)



18-5758
CAJA DE ENCENDIDO
Reemplaza: 582453, 583380, 582452



18-5759
CAJA ENCENDIDO
Reemplaza: 582125, 581805



18-5760
CAJA ENCENDIDO
Reemplaza: 582138, 582400, 582642, 582556



18-5761
CAJA ENCENDIDO
Reemplaza: 583114



18-5762
CAJA ENCENDIDO
Reemplaza: 582115



18-5763
CAJA ENCENDIDO
Reemplaza: 582285, 583170



18-5764
CAJA ENCENDIDO
Reemplaza: 582261, 586696



18-5766
CAJA ENCENDIDO
Reemplaza: 583748



18-5767
CAJA ENCENDIDO
Reemplaza: 584783



18-5768
CAJA ENCENDIDO
Reemplaza: 584908, 5001344



18-5770
CAJA ENCENDIDO
Reemplaza: 584028



18-5771
CAJA ENCENDIDO
Reemplaza: 584032



18-5772
CAJA ENCENDIDO
Reemplaza: 584041



18-5773
CAJA ENCENDIDO
Reemplaza: 584642, 763803



18-5774
CAJA ENCENDIDO
Reemplaza: 585145, 5004532



18-5781
CAJA ENCENDIDO
Reemplaza: 586661, 584636, 586212,
585114



18-5794-1
MODULO ENCENDIDO
Reemplaza: 584489, 584329, 583896,
584331



18-5782
CAJA ENCENDIDO
Reemplaza: 582705, 763793



18-5783
CAJA ENCENDIDO
Reemplaza: 582811, 763794



18-5784
CAJA ENCENDIDO
Reemplaza: 583110



18-5785
CAJA ENCENDIDO
Reemplaza: 585261



18-5794
CAJA ENCENDIDO
Reemplaza: 584489, 584329,
583896, 584331



18-5883
CAJA ENCENDIDO
Reemplaza: 584488





18-5885
CAJA ENCENDIDO
Reemplaza: 583865
Para: V-6 5800 rpm limite



18-5886
CAJA ENCENDIDO Y SENSOR
Reemplaza: 436367, 584122
Para: Los motores V6 con sensor óptico y funda azul en el módulo de alimentación. No usar con manga larga gris stator.



18-5887
CAJA ENCENDIDO
Reemplaza: 584985
Para: Los motores V6 con sensor óptico y funda gris sobre power pack. No usar con manga negra stator



18-5891
CAJA ENCENDIDO
Reemplaza: 583605
Para: 3 & 6 cil. 6700 rpm limite



18-5893
CAJA ENCENDIDO
Reemplaza: 586667, 584037, 586217, 583476
Para: V-4 & V-8 6700 rpm limite



18-5884
SENSOR ÓPTICO
Reemplaza: 586343
Para: V-4 & V-6



18-9802
LUZ TIMING
Autoalimentado precisos hasta 10,000 RPM

Modelo	Años	Caja encendido	Modelo	Años	Caja encendido	Modelo	Años	Caja encendido
4	1977-80,1984	18-5758	25	1985	18-5765	48	1987-88	18-5763
4	1993	18-5883	25	1986-88	18-5763	48	1991-93	18-5794
4 DLX	1986-88, 1994-99	18-5763	25	1989-92	18-5794	50	1971-75	18-5755
4.5	1980-84	18-5758	25	1993-95	18-5768	50	1979,1981-84	18-5758
4.5	1986-87	18-5763	25	1996-01	18-5768 ⑩	50	1985	18-5765
5	1984	18-5758	25 COM.	1986-88	18-5764 ⑦	50	1986-88	18-5763
5	1985		28	1986-88	18-5763	50	1991-93	18-5794
5	1986-88, 1993-98	18-5763	28	1989-92	18-5794	50 Arranq. manual	1993- 01	18-5768
6	1977-79,1984	18-5758	28	1996-01	18-5768	50 Arranq. elect	1993- 01	18-5785
6	1985	18-5765	30	1984	18-5758	50 (3 cil)	1996-99	
6	1986-88, 1993-01	18-5763	30	1985		55	1976-77	18-5755
6.5COM.	1992-99	18-5763	30	1986-88	18-5763	55	1978-82	18-5758
7.5	1980-83	18-5758	30	1989-92	18-5794	55	1991-92	18-5794
8	1993-95	18-5763	30	1993-95	18-5768	60	1970-71	—
9.9,15	1977-84	18-5758	30	1996-01	18-5768 ⑩	60	1980-84	18-5758
9.9,15	1985		35	1977-84	18-5758	60	1985	
9.9,15	1986-88	18-5763	35	1985		60	1986-88	
9.9,15	1993-99	18-5767 ②	35	1986-88	18-5763	60	1989-92	18-5766
14	1987	18-5763	35	1989-92	18-5794	60	1993-95	18-5774 ⑧
10/15COM.	1992	18-5763	35	1993-95	18-5768	60	1996-99	18-5780 ⑧
10,15COM.	1993-99	18-5767	40	1982	18-5758	65	1972-73	
20	1981-84	18-5758	40	1985		65	1989-92	18-5766
20	1985		40	1986-88	18-5763	65	1993-95	18-5774 ⑧
20	1986-88	18-5763	40	1991-93	18-5794	70	1974-78	18-5754 ③
20	1989-92	18-5794	40 Arranq. manual	1993- 01	18-5768	70	1979-84	18-5760
20	1993-95	18-5768	40 Arranq. eléct	1993- 01	18-5785	70	1985	18-5782 ⑧
20	1996-01	18-5768 ⑩	40 COM.	1986-88	18-5764	70	1986-88	
25	1977-84	18-5758 ④	45	1991-92	18-5794	70	1989-92	18-5766

① 2 cajas encendido por motor
 ② Pida 18-5756 para Cajas encendido sin tapa, y tornillo de montaje
 ③ Pida 18-5757 para cajas encendido sin tapa, y tornillos de montaje

④ Todos los modelos excepto Worktwin, Workhorse y modelo comercial de 1983
 ⑤ Sólo para Babor 1983 modelo STLCT
 ⑥ Sólo para babor 1984 modelos con sufijo que empiece por "S"
 ⑦ 2 cil. sólo

⑧ 3 cil. sólo
 ⑨ Sea Drive Series
 ⑩ Excepto modelos remoto
 ❶ Consulte la imagen
 ❷ Sólo modelos 2 tiempos

APLICACIONES CONTINUAN EN LA SIGUIENTE PÁGINA

Modelo	Años	Caja encendido	Modelo	Años	Caja encendido	Modelo	Años	Caja encendido
70	1993-95		110	1986-87	18-5784	185	1984	18-5760 ①
70	1996-99	18-5780 ⑧	110	1988	—	185	1990, 1992	18-5893
75	1975-78	18-5754 ③	115	1969-70	—	185	1993-99	18-5781
75	1979-84	18-5760	115	1973-77	18-5753 ②	200	1976-78	18-5754 ③①
75	1985	18-5782 ⑧	115	1978-84	18-5759 ①	200	1979-83	18-5760 ①
75	1986-88	18-5762 ⑧	115	1985	18-5783	200	1987	18-5891
85	1969-72	—	120	1986	—	200, 225	1988-92	18-5893
85	1973-77		120	1988-99	18-5772	200, 225	1993-99	18-5781
85	1978-80	18-5759 ①	125	1971-72	—	225	1987	18-5891
88, 90	1986-87	18-5784	130	1988-99	18-5772	235	1978	
88	1988	—	135	1973-76	18-5753 ②	235	1979-84	18-5760 ①⑤⑥
88,90	1989-99 Crossflow	18-5770	140	1977		250	1991	18-5893
90	1981-83	18-5759 ①	140	1978-83	18-5759 ①	275	1986-87	—
90	1985	18-5783	140	1986	—	300	1987	—
90	1988	—	140	1988-99	18-5772	300	1991	18-5893
100	1971	—	150	197-78		V-8	1993-99	18-5773
100	19,681,972	—	175	1979-83	18-5760 ①	1.6L	1984 & prior	18-5759 ⑨
100	1979-80	18-5759 ①	175	1986-88	18-5761	1.6L	1985	18-5782
100	1988	—	175	1989-91	18-5885	1.6L	1986-87	18-5784
100, 115	1989-99 Crossflow	18-5770	175	1991-92	18-5886 ⑦	2.0L	1988-99	18-5772
110 (Sólo TCLDF)	1986	18-5783	175	1993-03	18-5887	2.5, 2.6L	1986-88	18-5761 ⑨

- ① 2 cajas encendido por motor
- ② Pida 18-5756 para Cajas encendido sin tapa, y tornillo de montaje
- ③ Pida 18-5757 para cajas encendido sin tapa, y tornillos de montaje
- ④ Todos los modelos excepto Worktwin, Workhorse y modelo comercial de 1983
- ⑤ Sólo para Babor 1983 modelo STLC
- ⑥ Sólo para babor 1984 modelos con sufijo que empiece por "S"
- ⑦ 2 cil.sólo
- ⑧ 3 cil. sólo
- ⑨ Sea Drive Series
- ⑩ Excepto modelos remotos
- ⑪ Consulte la imagen
- ⑫ Sólo modelos 2 tiempos

CABLES DE BUJÍAS MARINOS DE ALTA CALIDAD

Sierra MAGFORCE Cables de encendido electrónica protege todos tus dispositivos electrónicos y los controles electrónicos del motor de RFI y EMI, además de ofrecer la máxima cantidad de tensión. Ajuste exacto diseño asegura una fácil instalación - servicio gratuito.

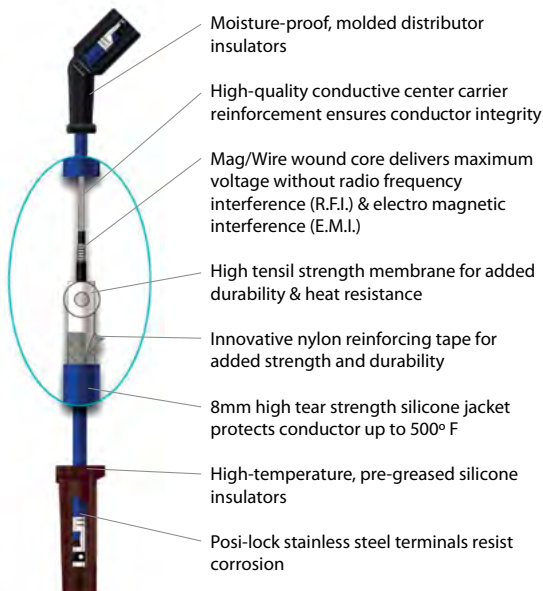

Ref #	OEM #	Descripción	Ref #	OEM #	Descripción
18-8815-1	OMC 582365	4" cable bujías	18-5230-9-1 ①③	Universal	10" cable bujías (pkg de 5)
18-8816-1	OMC 582365	6" cable bujías	18-8839-1	—	90 & 115 hp juego de cables fueraborda 2 - 14" • 2 - 16"
18-5231-1	OMC 582365	9" cable bujías	18-8840-1	—	150 & 175 hp juego cables fueraborda 2 - 14" • 2 - 16"
18-5231-1D ②	OMC 582365	9" cable bujías	18-28090	—	V6 Juego de cables fueraborda
18-8818-1	OMC 582365	12" cable bujías	18-28092	—	V4 Juego de cables fueraborda
18-5229-9-1 ①③	Universal	22" cable bujías (pkg de 5)			

Pack. de 10



18-5224
18-5224-9①
CABLE TERMINAL ENCENDIDO
Reemplaza: 510364



18-5225
KIT CABLE BUJÍAS
Incluye 25 pies cable encendido Hypalon con conductor de cobre y un largo surtido de 3 terminales diferentes para motores Johnson/Evinrude.



18-5226
CABLE ENCENDIDO
(100'bobina)
Hypalon
Reemplaza: 510883, 772584

Pack. de 10



18-5750
18-5750-9①
TAPA BUJÍAS UNIVERSAL
Suministro completo con conector terminal
Reemplaza: 581027, 580339



18-5752
TAPA BUJÍAS UNIVERSAL
8mm



MP39100
LLAVE ENCENDIDO
Reemplaza: 386545
(5 Terminales - 3 Posiciones)



MP39760
LLAVE ENCENDIDO
Reemplaza: 393301, 508180
(6 Terminales - Push to Choke - 3 Posiciones)



MP39830
LLAVE ENCENDIDO
Reemplaza: 386545
(6 Terminales - Pistol Shaped Key - 3 Posiciones)
Pollak



MP28890
HOMBRE AL AGUA
Reemplaza: 176288
1996-Nuevo



18-1282
CABLE Y CLIP HOMBRE AL AGUA
Reemplaza: 398602
Tiller Steer Modelos - Todos



MP28870
MP28872 (Bulk - 100 pc/carton)
CABLE Y CLIP HOMBRE AL AGUA
Reemplaza: 585134



MP28880
CABLE HOMBRE AL AGUA
Reemplaza: 432230
1995-antiguo

① Precio por pack

**JOHNSON/EVINRUDE
APLICACIONES STATOR**

HP	Año inicial	Año final	Stator
185	1993	1994	18-5877
200	1993	2001	18-5877
225	1993	2001	18-5877
250	1993	2001	18-5877
300	1993	1995	18-5877
150	1993	2006	18-5878
175	1993	2006	18-5878



**MP28900*
CABLE**
Reemplaza: 432230
1995-antiguo



**18-5877
STATOR**
Reemplaza: 584643, 763779
Para: 185-300 HP (1993-2001)



**18-5878
STATOR**
Reemplaza: 584981, 763759
Para: 150-175 HP (1993-2006)



**18-6277
ALOJAMIENTO TILT/TRIM**
Reemplaza: 435548
Heavy Duty, 2 cable conexión, Eje plano
(Aro incluido)
Para: OMC V6(1993), Comercial V8 (1993-sup)



**18-6823
CABLEADO**
Reemplaza: Universal
Convierte 3-cables Tilt y Trim motores a 2-cables



**18-6280
ALOJAMIENTO TILT/TRIM**
Reemplaza: 437801
Heavy Duty, OMC J Suffijo 40,48,50HP(1992-sup)con 2 cables conexión
(Aro incluido)



**18-6281
MOTOR TILT/TRIM**
Reemplaza: 438786, 439937, 5005254
(Aro incluido)
Plástico alojamiento Heavy Duty para OMC fuerabordas 75HP-250HP EFI(1998-sup)



**18-6285
ALOJAMIENTO TILT/TRIM**
Reemplaza: 433226
(Aro incluido)
Heavy Duty OMC (1989-92) M Suffijo 40,48,50HP con 2 cables de conexión y eje hex



**18-6756
MOTOR TILT/TRIM**
Reemplaza: 172588, 173944
Para: (1982-98) 2 cilindros 2 los motores que han sido encajados con el kit de inclinación 173946.



**18-6759
MOTOR TILT/TRIM**
Reemplaza: 394176, 391264, 393988, 985237
Diseño nuevo de 2 cables para mayoría de aplicaciones 3,4,6 y 8 cil. Desde 1982 hasta hoy.
(SÓLO MOTOR)
Use 18-7510 Aro (Aro incluido)
Reemplaza: 321163



**18-6761
MOTOR TILT/TRIM**
Reemplaza: 387277, 582048, 582155, 584107
(Aro incluido)
Diseño de 3 cables para mayoría 3, 4, 6 cilindros fuerabordas a partir de 1981
(Sólo Motor)



**18-6762
MOTOR TILT/TRIM**
Reemplaza: 172543
Para mayoría 85, 115 & 135 hp aplicaciones v-4 (Motor y depósito)



**18-6767-1
MOTOR TILT/TRIM**
Reemplaza: 172850, 173564, 173596
Para: 1974 (115 & 135 HP)
Para mayoría de modelos comerciales 45 hp 1989-90,
2 cilindros aplicaciones (1984-88),
3 cilindros aplicaciones (1977-83) y
4 cilindros aplicaciones (1974-77)
(Motor y depósitos)
Para kit reparación 18-6252



**18-6780
MOTOR TILT/TRIM**
Reemplaza: 438529, 438531, 434496
Para: 90, 115, 200, 225 HP (1991-sup); 120, 140 HP (1991-94); 130 HP (1995-sup)



**18-6815
MOTOR TRIM**
Reemplaza: Johnson/Evinrude
Para: 2004-09 40-50HP 2006-09 60HP, 2009 25-30HP Evinrude



**18-6744
TRIM MOTOR**
Reemplaza: 5006319
Para: 75-90 HP (04-Sup), 115 HP (07-Sup), 130 HP (10-Sup)



**18-6816
TRIM MOTOR**
Reemplaza: 172588, 173944
Para: 40, 50, 70 y 75HP con eje corto



**18-6252
KIT REPARACIÓN
MOTOR TILT & TRIM**
Para usar con 18-6767-1
* Incluye escobillas



POWER TRIM

Ref NO.	OE NO.	APLICACION
18-6801	5005114	115-130HP, V4 (2000-09)
18-6802	5005113	135-200HP, V6, 60° (2000-09)
18-6803	5005115/5007662	200-250HP, V6, 90° (2000-09)



**18-5705
POWER TRIM RELÉ**

Reemplaza:
582472, 584416, 586224
5 Terminal • Tirador
Tiro doble • 12 Volt

Contacto	Resistive	Conductive
Abierto	40 Amps	30 Amps
Cerrado	20 Amps	15 Amps



①18-5801D

Display Package

**18-5801
SOLENOIDE**
Reemplaza: 985064, 58586730

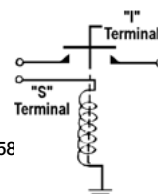

⑥18-5823D

Display Package

**18-5823
SOLENOIDE**

Reemplaza: 584580
Para: 9.9 4-tiempos(1995-01), 9.9 (1993 & sup),
15 4-tiempos(1995-01), 15 (1993 & sup),
8 (1996-98),

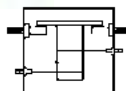

⑥18-5833D

Display Package

**18-5833
SOLENOIDE**

Reemplaza: 586774
Para: E40 (2004-07), E50 (2004-06), E60 (2006-07), E75 (2004-07), E90 (2004-07),
E115 (2007), E150 (2007), E175 (2007), E200 (2005-07), E225 (2005-07), E250 (2005-07)

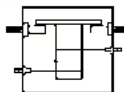

**18-5807
SOLENOIDE**

Reemplaza: 3/8444,
Prestolite SAW4206

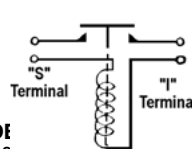

⑥18-5808D

Display Package

**18-5808
SOLENOIDE**

Reemplaza: 395419, 582708

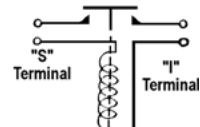

**18-5813
SOLENOIDE**

Reemplaza: 584128

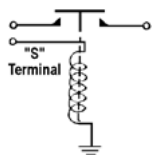

⑥18-5814D

Display Package

**18-5814
SOLENOIDE**

Reemplaza: 581528, 172869

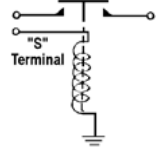

CABLES BATERÍA

Cable con terminales para roscas 3/8".

Ref No.	talla	Color	Calibre	Ref No.	talla	Color	Calibre
BC88523	2'	rojo	4	BC88563	6'	rojo	2
BC88533	2'	negro	4	BC88573	6'	negro	2
BC88543	4'	rojo	2	BC88583	8'	rojo	1
BC88553	4'	negro	2	BC88593	8'	negro	1

JOHNSON/EVINRUDE APLICACIÓN ARRANQUE SOLENOIDE

HP	Año inicial	Año final	Arranque Solenoide	HP	Año inicial	Año final	Arranque Solenoide
9.9	1990	1992	18-5813	33	1968	1970	18-5808
15	1990	1992	18-5813	35	1957	1959	18-5807
18	1957	1959	18-5807	35	1976	1988	18-5808
20	1985	1998	18-5808	35	1991	2001	18-5808
25	1972	2005	18-5808	40	1960	1966	18-5807
25	2009	2009	18-5833	40	1967	1976	18-5808
28	1986	1996	18-5808	40	1984	2005	18-5808
30	1984	2005	18-5808	40	2004	2009	18-5833
30	2009	2009	18-5833	45	1989	1992	18-5808
33	1965	1967	18-5807	48	1987	1996	18-5808

REFERENCIAS ACABADAS EN "D" ENVASADAS. REFERENCIAS NORMAL, NO ENVASADAS
APLICACIONES CONTINUAN EN LA SIGUIENTE PÁGINA

JOHNSON/EVINRUDE APLICACIONES ARRANQUE SOLENOIDE(CONT.)

HP	Año inicial	Año final	Arranque Solenoide	HP	Año inicial	Año final	Arranque Solenoide
50	1958	1959	18-5807	100	1984	2001	18-5808
50	1971	1975	18-5808	105	1998	2003	18-5808
50	1979	2005	18-5808	110	1986	1989	18-5808
50	2004	2009	18-5833	112	1994	1996	18-5808
55	1968	1969	18-5808	115	1969	1970	18-5808
55	1976	1981	18-5808	115	1973	1985	18-5808
55	1989	1992	18-5808	115	1990	2006	18-5808
55	1996	1997	18-5808	115	2007	2009	18-5833
55	2008	2009	18-5833	120	1985	1994	18-5808
60	1964	1966	18-5807	125	1971	1972	18-5808
60	1967	1971	18-5808	125	1989	1990	18-5808
60	1980	2001	18-5808	125	1992	1998	18-5808
60	2006	2009	18-5833	130	1995	2000	18-5808
65	1968	1968	18-5808	130	2009	2009	18-5833
65	1972	1973	18-5808	135	1973	1976	18-5808
65	1984	2001	18-5808	135	2001	2001	18-5808
65	2008	2009	18-5833	140	1977	1994	18-5808
70	1970	2001	18-5808	150	1978	2006	18-5808
75	1960	1964	18-5807	150	2007	2009	18-5833
75	1965	1965	18-5807 ①	155	1984	1992	18-5808
75	1965	1965	18-5808 ②	175	1977	2006	18-5808
75	1975	1988	18-5808	175	2007	2009	18-5833
75	2004	2009	18-5833	185	1984	1985	18-5808
80	1966	1966	18-5807 ①	185	1989	1994	18-5808
80	1966	1967	18-5808 ②	200	1976	2001	18-5808
85	1968	1980	18-5808	200	2005	2009	18-5833
85	1991	1995	18-5808	225	1986	2001	18-5808
88	1987	1996	18-5808	225	2005	2009	18-5833
90	1964	1964	18-5807	235	1978	1985	18-5808
90	1965	1965	18-5808	250	1991	2001	18-5808
90	1981	2006	18-5808	250	2005	2009	18-5833
90	2004	2009	18-5833	275	1985	1988	18-5808
100	1966	1968	18-5808	300	1985	1995	18-5808
100	1971	1972	18-5808	300	2008	2009	18-5833
100	1979	1980	18-5808				

① Sin cambio eléctrico ② con cambio eléctrico

JOHNSON/EVINRUDE APLICACIÓN TRIM RELÉ/SOLENOIDE

HP	Año inicial	Año final	Trím Relé / Solenoide	HP	Año inicial	Año final	Trím Relé / Solenoide
60	1986	2001	18-5705	125	1989	1998	18-5705
65	1991	1995	18-5705	135	1976	1976	18-5814
70	1980	1981	18-5814	140	1977	1981	18-5814
70	1981	2001	18-5705	140	1981	1994	18-5705
75	1980	1981	18-5814	150	1978	1981	18-5814
75	1982	1987	18-5705	150	1981	2006	18-5705
75	2000	2003	18-5705	175	1977	1981	18-5814
85	1976	1980	18-5814	175	1981	2006	18-5705
85	1991	1995	18-5705	185	1984	1985	18-5705
88	1986	1996	18-5705	185	1990	1994	18-5705
90	1981	1981	18-5814	200	1976	1981	18-5814
90	1981	2006	18-5705	200	1981	1983	18-5705
100	1979	1980	18-5814	200	1986	2005	18-5705
100	1984	2005	18-5705	225	1986	2005	18-5705
110	1986	1989	18-5705	235	1978	1981	18-5814
115	1976	1981	18-5814	235	1981	1985	18-5705
115	1981	1985	18-5705	250	1991	2005	18-5705
115	1990	2006	18-5705	275	1985	1988	18-5705
120	1985	1994	18-5705	300	1985	1995	18-5705



18-5708
RECTIFICADOR
 Reemplaza : 582399, 583408
 6-10 AMP

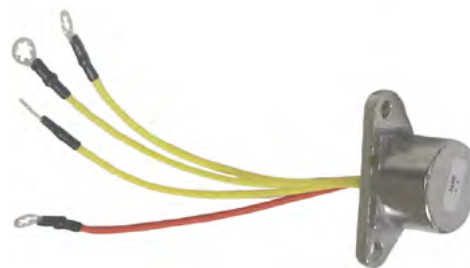

18-5709
RECTIFICADOR
 Reemplaza: 581778
 4-5 AMP



18-5825
REGULADOR/RECTIFICADOR
 Reemplaza: 395204



18-5826
REGULADOR/RECTIFICADOR
 Reemplaza: 584890



18-5827
REGULADOR/RECTIFICADOR
 Reemplaza: 585001, 584476



18-5828
REGULADOR/RECTIFICADOR
 Reemplaza: 585219, 439561



18-5829
REGULADOR/RECTIFICADOR
 Reemplaza: 586048



18-5830
REGULADOR/RECTIFICADOR
 Reemplaza: 586075

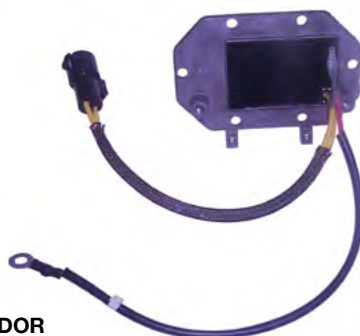

18-5831
REGULADOR/RECTIFICADOR
 Reemplaza: 586271, 584641, 585995



18-5832
REGULADOR/RECTIFICADO
 Reemplaza: 583266, 583689,
 586000, 584424

Modelo	Año	Ref #	Modelo	Año	Ref #
9.9,15	1974-92	18-5709	90	1981-92	18-5708
20	1989-98 ④	18-5709	90-115 60 GRADOS-V4	1996-SUP	18-5830
25	1977-03 (2 CIL) ④	18-5709	100	1971,1979-80,1984-92 ③	18-5708
25/40/50TL/ J ELEC TR	1992	18-5827	115	1973-92	18-5708
25SIK/ SIL/ SIT	1994-1995	18-5827	120/140	1985	18-5832
25/35 3 CIL.	1995-UP	18-5826	125	1971-72	18-5708
28	1989-96	18-5709	135	1974 ⑦	18-5708
30	1989-03 (2 CIL) ④	18-5709	135	1973,1975-76	18-5708
35	1976-93 (2 CIL) ④	18-5709	140	1977-88	18-5708
35JET/ TL/ J ELEC.	1992-1993	18-5827	150	1979-88	18-5708
35JET/ M-TE/ TTL	1993-1995	18-5827	150/175 60 GRADOS-V6	1991-1995	18-5828
35JET/ EL/ TL/ TTL	1996	18-5827	150/175 60 GRADOS-V6	1996-SUP	18-5829
35JET ELEC.	1997	18-5827	155	1984-88	18-5708
40	1974-76,1988-92	18-5709	175	1977-83	18-5708
40/50TE/ EL/ TL/ TTL	1993-1996	18-5827	185	1984-88	18-5708
40/ 50 ELEC. 2 CICLO.	1993-03 (2 CICLO.)	18-5827	185/200/225	1993-1994	18-5831
45	1989-92 COMM	18-5709	185/200/225/200COMM	1990-1992	18-5832
45SS	1989-90	18-5709	200	1976-83	18-5708
48	1989-92	18-5709	200/225	1986-1989	18-5832
50	1971-75	18-5708	200/225/200COMM	1994-1997	18-5831
50	1979-92	18-5709	235	1978-88	18-5708
55	1976-77	18-5708	250/300	1991-1995	18-5831
55	1978-81, 1980-92 ①	18-5709	250	1997	18-5831
60	1970 ⑤, 1971	18-5708	275	1985-1986	18-5832
60	1980-88	18-5709	275/300 (3.6L)	1987	18-5832
60	1989-91 ⑥	18-5708	275/300	1988	18-5832
SST60	1989-90	18-5708	300 (3.6L) — BABOR & EST.	1985-1986	18-5832
60	1992-01	18-5827	300	1989-1990	18-5832
65	1972-73, 1988-91	18-5708	1.8/2.0L V4 "S"	1987-1990	18-5832
65 ELEC.	1992	18-5827	2.7L V6	1986-1987	18-5832
70	1974-91 ②	18-5827	3.0L V6	1988-1990	18-5832
70	1992-01	18-5708	3.0L V6	1993-1998	18-5832
75	1975-88	18-5708	3.6L V8	1987	18-5832
85	1970-80	18-5708	4.0L V8	1989-1990	18-5832
88	1989-92	18-5708	V-4 & V-6 Crossflow con 35 AMP	TODOS	18-5825

- ① También modelos comerciales
- ② Sólo modelos 1991 EL & TL
- ③ Excepto modelos 1992 WTLNE & WTX-

- ENE
- ④ Solo encendido eléctrico

- ⑤ Sólo modelos D
- ⑥ Sólo modelos EL & TL
- ⑦ Sólo modelos 135443, 135483



18-6434
ARRANQUE FUERABORDAS
Reemplaza: 386430, 763454
Para: 9.9,15 HP (1974-92), 8 HP 4 tiempos (1996-98)



18-5640
ARRANQUES FUERABORDAS
Reemplaza: 395207, 387094, 585062, 586288, 778992
Para: 150-235 HP, V6 modelos



18-5909
ARRANQUES FUERABORDAS
Reemplaza: 587078, 587291
Para: Evinrude G2 Engines: C150(AA-AB), C175 (AA-AB), A200 (AF-AG), C200 (AA-AB), E200 (AB-AG), H200 (AG-AH), E225 (AB-AG), H225 (AG-AH), A250 AF-AG, E250 (AB-AG), H250 (AG-AH), A300 (AF-AG), E300 (AB-AG), H300 (AG-AH)

TODOS LOS ARRANQUES SON EN SENTIDO CONTRARIO A LAS AGUJAS DEL RELOJ
APLICACIONES ARRANQUE EMPIEZAN EN LA PÁGINA 151



18-5612
ARRANQUE FUERABORDA
Reemplaza: 432925, 586287, 586286
Para: 175 HP modelos (1992)



18-5617
ARRANQUE FUERABORDA
Reemplaza: 586274, 778995
Para: 9.9, 15 HP modelos



18-5619
ARRANQUE FUERABORDA
Reemplaza: 584799, 396235, 391511, 397023, 586731, 586890
Para: V6/V8 Looper modelos



18-5624
ARRANQUE FUERABORDA
Reemplaza: 583482, 585056, 586279
Para: 20-35 HP models (1989 & sup)



18-5627
ARRANQUE FUERABORDA
Reemplaza: 583473, 585059, 585459, 778991
Para: 20-35 HP modelos (1987-93)



18-5628
ARRANQUE FUERABORDA
Reemplaza: 393570, 585060, 586285, 778994
Para: 140 HP modelos (1993)



18-5629
ARRANQUE FUERABORDA
Reemplaza: 392133, 585061, 386591, 586278
Para: 18-40 HP modelos



18-5630
ARRANQUE FUERABORDA
Reemplaza: 387684, 585063, 389275, 384163, 586280, 778993
Para: 50-60 HP, 2 cil. modelos



18-5631
ARRANQUE FUERABORDA
Reemplaza: 584818, 586277, 778996
Para: V-4, 60° modelos (1997 & sup)



18-5632
ARRANQUE FUERABORDA
Reemplaza: 584980, 586284
Para: V-4, 60° modelos (1997 & sup)



18-5634
ARRANQUE FUERABORDA
Reemplaza: 585057, 585051, 385529, 389954, 586283
Para: 140 HP modelos (1977)



18-5648
ARRANQUE FUERABORDA
Reemplaza: 585058, 586281, 386657, 391735, 585050, 384777
Para: 70 HP modelos

**TODOS LOS ARRANQUES SON EN SENTIDO CONTRARIO A LAS AGUJAS DEL RELOJ
APLICACIONES ARRANQUES EMPIEZAN EN LA SIGUIENTE PÁGINA**



18-6826
ARRANQUE
Reemplaza: 586768, 587045
Para: 40-90HP E-Tec



18-6863
ARRANQUE
Reemplaza: 584608, 586275
Para: Johnson/Evinrude 9.9-15HP 4-tiempos



18-6945
ARRANQUE
Reemplaza: 5036972
Para: Johnson, Suzuki 25HP 2006-11



18-6250
ARRANQUE FUERABORDA
KIT REPARACIÓN
Prestolite
2 Escobillas



18-6251
ARRANQUE FUERABORDA
KIT REPARACIÓN
Prestolite
4 Escobillas



18-5655
CONJUNTO PIÑONES
Reemplaza: 321648
Vea la siguiente página para aplicaciones adicionales



18-5671
CONJUNTO PIÑONES
Reemplaza: 384781
Vea la siguiente página para aplicaciones adicionales



18-5674
CONJUNTO PIÑONES
Reemplaza: 387683
Vea la siguiente página para aplicaciones adicionales



18-5678
CONJUNTO PIÑONES
Reemplaza: 585269, 586101
Vea la siguiente página para aplicaciones adicionales



18-5679
CONJUNTO PIÑONES
Reemplaza: 585267, 586100
Vea la siguiente página para aplicaciones adicionales



18-5697
KIT ESCOBILLAS Y MUELLES
Reemplaza: 385952
Vea la siguiente página para aplicaciones adicionales

HP	AÑOS	Arranque #	O.E. Ref #	O.E. #	Ens.Transmisión ²	O.E. #	Nº de dientes	kit escobillas ²	O.E. #
9.9/ 15	1974-92	—	386430	395264	—	319977	10	ND	ND
9.9/ 15	1993 & SUP	18-5617	586274	395264	—	319977	10	ND	ND
9.9/ 15	1997 & sup 4 T	—	584613	NSS	18-5679 ①	585267	10	18-5697	385952
20 ⑦	1985-88	18-5629	586278	393354	18-5655	321648	11	18-5697	385952
20 hasta 30 ⑦	1993-98	18-5629	586278	393354	18-5655	321648	11	18-5697	385952
25 hasta 35 ⑦	1977-88	18-5629	586278	NSS	18-5655	321648	11	18-5697	385952
20 hasta 30 ⑤	1989-92	18-5627	585059	393354	18-5671 ①	384781	9	18-5697	385952
25 hasta 35	1997-99 3 cilindros	18-5631	586277	586100	NSS ①	NSS	10	18-5697	385952
40-50	1984-88	18-5630	586280	NSS	18-5671 ①	384781	9	18-5697	385952
50	1972	18-5630	586280	NSS	18-5671 ①	585269	9	18-5697	385952
40-50 ①	1989-99	18-5624	586279	NSS	18-5678 ①	585269	9	18-5697	385952
55	1978	18-5630	586280	NSS	18-5678 ①	585269	9	18-5697	385952
60	1985 2 cilindros	18-5630	586280	NSS	18-5678 ①	585269	9	18-5697	385952
50	1985-99 3 cilindros	18-5648	586281	NSS	18-5678 ①	585269	9	18-5697	385952
55	1969	18-5648	586281	NSS	18-5678 ①	585269	9	18-5697	385952
60	1971	18-5648	586281	NSS	18-5671*	384781	9	18-5697	385952
60	1986-01 3 cilindros	18-5648	586281	NSS	18-5678 ①	585269	9	18-5697	385952
65	1985-01 3 cilindros	18-5648	586281	NSS	18-5678 ①	585269	9	18-5697	385952
70, 75	1980-01	18-5648	586281	NSS	18-5678 ①	585269	9	18-5697	385952
85 hasta 115	1973-99 crossflows	18-5634	586283	NSS	18-5679 ①	586100	10	18-5697	385952
90, 115	1995-99 looper	18-5632	586284	ND	ND	ND	ND	18-5697	385952

**TODOS LOS ARRANQUES CON ROTACIÓN HACIA LA IZQUIERDA
APLICACIONES ARRANQUES CONTINUAN EN LA SIGUIENTE PÁGINA**

HP	AÑOS	Arranque #	O.E. Ref #	O.E. #	Ens.Transmisión ^②	O.E. #	Nº de dientes	kit escobillas ^②	O.E. #
120 hasta 140	1985-94	18-5628	586285	NSS	18-5679 ^①	586100	10	18-5697	385952
130	1995-99	18-5628	586285	NSS	18-5679 ^①	586100	10	18-5697	385952
V-6 Crossflow	1976-92	18-5640	586288	393285	18-5674	387683	8	18-5697	385952
150, 175 60°	1991-99 loopers	18-5612	586286	ND	ND	ND	ND	18-5697	385952
150 a 175 V-6	1997-03	18-5612	586287	NSS	NSS	ND	ND	ND	433850
200 hasta 300	1986-sup std. rotac.	18-5619	586411	397375	ND	ND	10	18-5697	385952

Nota: algunos arranques también sustituyen versiones prestolite, pero los repuestos sirven sólo para bosh.
* Eje con tuerca
NSS No se vende por separado

① El kit de ens transm. incluye conjunto de piñones con retén de modelo clip
② Los kits de transmisión, conjuntos, de piñones y escobillas son sólo para arranques bosh.

⑤ Con 9 dientes en piñones
⑦ Para modelos bosh

4-TIEMPOS KITS SISTEMA COMBUSTIBLES



18-7761
KIT RECUPERACIÓN CARBURADOR
Para: Johnson/Evinrude 4-tiempos 4-6 hp. (2007)



18-7773
KIT RECUPERACIÓN CARBURADOR
Reemplaza: 5032424
Para: 25, 30 HP (2000-01) (2004 & sup)

KIT SISTEMA COMBUSTIBLE 2 TIEMPOS



18-7010
KIT CARBURADOR
Reemplaza: 382050, 382051, 382054



18-7024
KIT CARBURADOR
Reemplaza: 382053, 382052, 385356, 439075



18-7026
KIT CARBURADOR
Reemplaza: 382057



18-7042
KIT CARBURADOR
(sin flotador)
Reemplaza: 392061, 398729, 396701



18-7222
KIT CARBURADOR
(con flotador)
Reemplaza: 392061, 398729, 396701



18-7043
KIT CARBURADOR
Reemplaza: 382045, 382046, 382047, 382049, 383052, 383067, 398532, 439071, 398514



18-7046
KIT CARBURADOR
Reemplaza: 390055, 392550, 398526, 435443, 434888, 439076, 433519
Contiene 18-7038 aguja/asiento



18-7219
KIT CARBURADOR
Reemplaza: 439073, 431897



18-7221
KIT CARBURADOR
Reemplaza: 435442, 438996

2-TIEMPOS KITS SISTEMA COMBUSTIBLE



18-7223
KIT CARBURADOR con aguja y asiento
Reemplaza: 398452, 391305, 398453, 439072, 391937



18-7247
KIT CARBURADOR
Reemplaza:
438996, 436852
Para: V4 & V6 (60°) 1988-2001

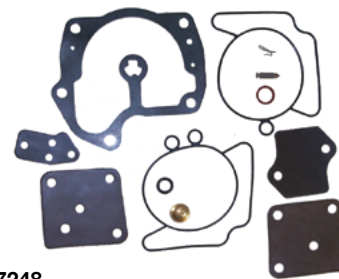

18-7248
KIT CARBURADOR
Reemplaza:
437327, 439079, 439078, 435676, 435677, 435678, 435752



18-0871
VÁLVULA DE SERVICIO CON ARO TÓRICO
Reemplaza: 175158
Para: Todos Johnson/Evinrude con válvula (excepto 1993 9.9 & 15hp.)



18-7044
KIT SERVICIO DE VÁLVULA
Para: Todos Johnson/Evinrude con válvula (excepto 1993 9.9 & 15 H.P.)



18-0993
JUNTA Y TAPA
Reemplaza: 437228
Para: Todos Johnson/Evinrude con válvula de cebado (excepto 1993 9.9 & 15hp.)



AGUJA Y ASIEN TO

Ref #	Reemplaza
18-7093	396521, 678882, 378895
18-7094	379313, 396522
18-7038	396520, 379312, 387262

PACK. DE 10



18-7106
18-7106-9 ①
EMBALAJE DE AGUA
Reemplaza: 307583



18-7210
FLOTADOR
Reemplaza: 382363

PACK. DE 5



18-7296
18-7296-9 ①
RETENEDOR AJUSTE AGUJA
Reemplaza: 315232

① Precio por pack

HP	AÑOS	KIT CARB. SIN FLOTADOR	KIT CARB. CON FLOTADOR	AGUJAS Y ASIEN TO	FLOTADOR CARBURADOR
1.5	1970-90	18-7043	—	18-7094	—
2	1970-90	18-7043	—	18-7094	—
3	1952-67	18-7043	—	18-7038	—
3	1968	18-7043	—	18-7094	—
4	1983-89	18-7223	—	18-7094	—
4	1991-93	18-7223	—	18-7094	—
4.5	1982-84,1987	18-7223	—	18-7094	—
5	1965-67	18-7043	—	18-7094	—
5	1968	18-7024	—	18-7093	—
5	1984-85	18-7223	—	18-7094	—
5.5	1954-67	18-7043	—	18-7094	—
6	1954-79	18-7043	—	18-7094	—
6	1968	18-7024	—	18-7093	—
6	1984-85	18-7223	—	18-7094	—
6, 8	1986-96	18-7219	—	—	—
7.5	1955-58	18-7043	—	18-7094	—
7.5	1982-83	18-7223	—	18-7094	—
8	1984-85	18-7223	—	18-7094	—
9.9	1974-88	18-7223	—	18-7094	—

① Comercial ② También Comercial ③ En producción ④ Corriente cruzada ⑤ Excepto 1995-sup 3 Cilindros Modelos

sistema combustible
JOHNSON / EVINRUDE (OMC/BRP)

HP	AÑOS	KIT CARB. SIN FLOTADOR	KIT CARB. CON FLOTADOR	AGUJAS Y ASIENTO	FLOTADOR CARBURADOR
9.9/15	1989-96	18-7219	—	—	—
10	1954-63	18-7043	—	18-7094	—
14	1968 ③	18-7223	—	18-7094	—
15	1955-56	18-7043	—	18-7094	—
15	1974-88	18-7223	—	18-7094	—
18	1957-68	18-7043	—	18-7094	—
18	1969-73	18-7042	18-7222	18-7093	18-7210
20	1957-68	18-7043	—	18-7094	—
20	1969-90	18-7042	18-7222	18-7093	18-7210
20	1991-96	18-7219	—	18-7094	—
25	1954-55	18-7024	—	18-7093	—
SAIL DR	1978-SUP	18-7042	18-7222	18-7093	18-7210
25	1969-95 ⑤	18-7042	18-7222	18-7093	18-7210
28	1962-64	18-7010	—	18-7093	—
28	1976-95	18-7042	18-7222	18-7093	18-7210
30	1956	18-7024	—	18-7093	—
30	1976-SUP	18-7042	18-7222	18-7093	18-7210
33	1965-70	18-7010	—	18-7093	—
35	1957-59	18-7024	—	18-7093	—
35	1959	18-7010	—	18-7093	—
35	1976-95 ⑤	18-7042	18-7222	18-7093	18-7210
40	1960-63, 1971	18-7010	—	18-7093	—
40	1965-70, 1972-78	18-7024	—	18-7093	—
40	1971-90, 1979-92 ①	18-7042	18-7222	18-7093	18-7210
45	1971-97 ②	18-7042	18-7222	18-7093	18-7210
48	1992-97	18-7042	18-7222	18-7093	18-7210
50	1958-59	18-7026	—	18-7093	—
50	1971-97	18-7042	18-7222	18-7093	18-7210
55	1968-69, 1971-97 ②	18-7042	18-7222	18-7093	18-7210
60	1964-67	18-7026	—	18-7093	—
60	1970-97	18-7042	18-7222	18-7093	18-7210
65	1972-97	18-7042	18-7222	18-7093	18-7210
70	1972-97 (3 CIL)	18-7042	18-7222	18-7093	18-7210
75	1960-63	18-7026	—	18-7093	—
75	1975-88	18-7042	18-7222	18-7093	18-7210
80	1966-67	18-7026	—	18-7093	—
85	1968	18-7026	—	18-7093	—
85	1971-79	18-7046	—	18-7093	—
85	1969-70, 1991-93	18-7046	—	18-7038	—
V-4	1969-79	18-7046	—	18-7038	—
V-4	1983-84	18-7046	—	18-7038	—
88,90	1985-95	18-7046	—	18-7038	—
90	1981-82, 1983 ③	18-7046	—	18-7038	—
90	1995-02	18-7247	—	—	—
100	1971, 1980	18-7046	—	18-7038	—
100	1972, 1979	18-7046	—	18-7093	—
100	1998-01	18-7247	—	—	—
105	1999-01	18-7247	—	—	—
115	1969, 1980-95	18-7046	—	18-7038	—
115	1995-02	18-7046	—	18-7093	—
115	1995-02	18-7247	—	—	—
V-6	1976-90 ④	18-7046	—	18-7038	—
115	1983	18-7046	—	18-7038	—
120	1985-90	18-7248	—	18-7094	—
120	1985-90, 1993	18-7248	—	18-7094	—
125	1971-72	18-7046	—	18-7093	—

① Comercial ② También Comercial ③ En producción ④ Corriente cruzada ⑤ Excepto 1995-Sup 3 Cilindro Modelos

HP	AÑOS	KIT CARB. SIN FLOTADOR	KIT CARB. CON FLOTADOR	AGUJAS Y ASIENTO	FLOTADOR CARBURADOR
125	1993	18-7248	—	18-7094	—
125C	1989-95	18-7248	—	18-7094	—
135	1973-76	18-7046	—	18-7093	—
140	1977, 1980-83	18-7046	—	18-7038	—
140	1978-79	18-7046	—	18-7093	—
140	1985-90	18-7248	—	18-7094	—
140	1993	18-7248	—	18-7094	—
150	1979-90	18-7046	—	18-7038	—
150	1992-96, 1998-02	18-7247	—	—	—
155	1984-93 ①	18-7046	—	18-7038	—
175	1977-91	18-7046	—	18-7038	—
175	1992-96, 1998-02	18-7247	—	—	—
185	1984	18-7046	—	18-7038	—
185	1989-93	18-7221	—	18-7094	—
200	1976-83	18-7046	—	18-7038	—
200	1986-90	18-7248	—	18-7094	—
200	1992-93	18-7221	—	18-7094	—
225	1986-90, 1992-93	18-7221	—	18-7094	—
235	1978-84	18-7046	—	18-7038	—
250	1991-93	18-7221	—	18-7094	—
275/3.6L	1985-88	18-7221	—	18-7094	—
300	1988, 1991-93	18-7221	—	18-7094	—

① Comercial ② También Comercial ③ En producción ④ Corriente cruzada ⑤ Excepto 1995-Sup 3 Cilindro Modelos



18-7350
BOMBA COMBUSTIBLE
Reemplaza: 397839, 391638, 395091, 397274
Para: 6/8/9.9/15 HP 1981-92
Use kit 18-7823



18-7351
BOMBA COMBUSTIBLE
Reemplaza: 434728, 438562
Para: 9.9/15 HP 1993-2006
Use kit 18-7800



18-7352
BOMBA COMBUSTIBLE
Reemplaza: 438556, 388268, 385781, 394543, 382354, 395713, 398338, 432451, 398387, 433387
Para: 25-55 HP 1976-89 (no-VRO)
Use kit 18-7821



18-7353
BOMBA COMBUSTIBLE
Reemplaza: 438555, 433386
Para: 20-30 HP 1990-2000
Use kit 18-7800



18-7800
KIT BOMBA COMBUSTIBLE
Reemplaza: 438616, 433519



18-7801
KIT BOMBA COMBUSTIBLE
Reemplaza: 379777



18-7820
KIT BOMBA COMBUSTIBLE
Reemplaza: 393103



18-7821
KIT BOMBA COMBUSTIBLE
Reemplaza: 398514, 395867



18-7822
KIT BOMBA COMBUSTIBLE
Reemplaza: 432962



18-7823
KIT BOMBA COMBUSTIBLE
Reemplaza: 393088

PACK. DE 2



18-7796
18-7796-9④
VÁLVULA DE COMPROBACIÓN
Reemplaza: 335334
(Ampliada para mostrar detalle)



18-3497
KIT DIAFRAGMA
Reemplaza: 5033372
4-5 HP (2003-06), 6 HP (2005-06)
4-tiempo



18-3498
KIT DIAFRAGMA
Reemplaza: 5036216, 5037584
10-15 HP (2005-07)
4-tiempos



18-3499
KIT DIAFRAGMA
Reemplaza: 5030699
9.9,15 HP (2002-04), 25HP (2004-06),
30HP (2004-07), 40-70 HP (2002-06)
4-tiempos

APLICACIÓN KIT REPARACIÓN BOMBA COMBUSTIBLE

Todos los kits son para no-VRO (TASA VARIABLE) bombas de lubricación

HP	Año inicial	Año final	kit rep. bomb. comb.	HP	Año inicial	Año final	kit rep. bomb. comb.	HP	Año inicial	Año final	kit rep. bomb. comb.
2.5	1987	1988	18-7823	25	2001	2001	18-3497④	50	1990	2012	18-7800
3	1989	1997	18-7823	25	2004	2005	18-3497④	50	AA	AG	18-7800
4	1982	2001	18-7823	28	1962	1963	18-7801	50	1999	2006	18-3497④
4	2003	2007	18-3497④	28	1986	1987	18-7821	55	1983	1984	18-7820
4.5	1982	1987	18-7823	28	1988	1990	18-7822	55	1985	1990	18-7821
5	1982	1983	18-7823	28	1990	1998	18-7800	55	1991	2005	18-7800
5	1985	1993	18-7823	30	1984	1984	18-7820	55	2008	2012	18-7800
5	1996	1998	18-7823	30	1985	1987	18-7821	55	AA	AG	18-7800
5	2003	2007	18-3497④	30	1988	1990	18-7822①	60	1964	1967	18-7801
6	1984	2005	18-7823	30	1990	2005	18-7800②	60	1982	1984	18-7820
6	1987	1987	18-7821	30	2001	2001	18-3497④	60	1985	1985	18-7821
6	2003	2007	18-3497④	30	2004	2007	18-3497④	60	1988	1988	18-7821
7.5	1980	1983	18-7823	35	1958	1959	18-7801	60	2002	2006	18-3497④
8	1982	2005	18-7823	35	1976	1984	18-7820	60	2005	2012	18-7800
8	1987	1987	18-7821	35	1986	1987	18-7821	60	AA	AG	18-7800
9.9	1974	1992	18-7823	35	1988	1990	18-7822	65	1984	1984	18-7820
9.9	1987	1990	18-7821②	35	1990	2001	18-7800	65	1985	1985	18-7800④
9.9	1990	1999	18-7800	40	1960	1964	18-7801	65	1985	1986	18-7821
10	1996	2007	18-7800	40	1971	1976	18-7820	65	1989	1989	18-7821
10	2002	2004	18-3497④	40	1983	1984	18-7820	65	1991	2001	18-7800
10	2005	2007	18-3497④	40	1985	1987	18-7821	65	2008	2012	18-7800
14	1988	1989	18-7823	40	1988	1990	18-7822①	65	AA	AF	18-7800
15	1974	1998	18-7823	40	1990	2012	18-7800②	70	1982	1984	18-7820
15	1987	1990	18-7821②	40	AA	AG	18-7800	70	1998	2006	18-3497④
15	1990	2007	18-7800	40	1999	2006	18-3497④	75	1960	1965	18-7801
15	2002	2004	18-3497④	45	1958	1959	18-7801	75	1982	1984	18-7820
15	2005	2007	18-3497④	45	1986	1990	18-7821	75	2004	2012	18-7800
20	1985	1987	18-7821	45	1991	1997	18-7800	75	AA	AF	18-7800
20	1988	1990	18-7822①	48	1987	1987	18-7821	80	1966	1967	18-7801
20	1990	1998	18-7800②	48	1988	1990	18-7822①	85	1977	1983	18-7820
25	1971	1976	18-7823	48	1990	1996	18-7800②	88	1987	1990	18-7821①
25	1977	1984	18-7820	50	1958	1959	18-7801	88	1990	1996	18-7800②
25	1985	1987	18-7821	50	1982	1984	18-7820	90	1964	1965	18-7801
25	1988	1990	18-7822①	50	1985	1987	18-7821	90	1981	1983	18-7820
25	1990	2005	18-7800②	50	1988	1990	18-7822	90	1997	1998	18-7800

④ Precio por pack

APLICACIONES CONTINUAN EN LA SIGUIENTE PÁGINA

APLICACIÓN KIT REPARACIÓN BOMBA COMBUSTIBLE

Todos los kits son para no-VRO (TASA VARIABLE) bombas de lubricación

HP	Año inicial	Año final	kit rep. bomb. comb.	HP	Año inicial	Año final	kit rep. bomb. comb.	HP	Año inicial	Año final	kit rep. bomb. comb.
90	2004	2012	18-7800	112	1994	1996	18-7800	150	1978	1984	18-7820
90	AA	AF	18-7800	115	1982	1983	18-7820	175	1977	1983	18-7820
100	1966	1966	18-7801	115	1997	1998	18-7800	200	1977	1983	18-7820
100	1989	1990	18-7821	115	2004	2005	18-7800	235	1978	1984	18-7820
100	1996	1997	18-7800	125	1995	1998	18-7800				
105	1997	2003	18-7800	140	1977	1983	18-7820				

④ Precio por pack

APLICACIONES CONTINUAN EN LA PRÓXIMA PÁGINA

APLICACIÓN BOMBA COMBUSTIBLE

HP	Año inicial	Año final	Bomba combustible	HP	Año inicial	Año final	Bomba combustible
6	1988	1991	18-7350	35	1990	1994	18-7353
8	1988	1991	18-7350	35	1996	1996	18-7353
9.9	1981	1992	18-7350	40	1968	1976	18-7352
9.9	1993	1999	18-7351	40	1983	1984	18-7352
10	1997	1998	18-7351	50	1974	1975	18-7352
10	2000	2001	18-7351	50	1979	1984	18-7352
10	2003	2007	18-7351	55	1976	1981	18-7352
15	1981	1998	18-7350	55	1983	1984	18-7352
15	1993	2007	18-7351	60	1980	1984	18-7352
20	1990	1998	18-7353	85	1977	1980	18-7352
25	1977	1984	18-7352	90	1981	1983	18-7352
25	1990	2005	18-7353	90	1997	1998	18-7352
28	1990	1996	18-7353	100	1979	1980	18-7352
30	1984	1984	18-7352	100	1997	1997	18-7352
30	1990	2005	18-7353	115	1977	1983	18-7352
33	1968	1970	18-7352	115	1997	1998	18-7352
35	1976	1984	18-7352	140	1977	1983	18-7352

KITS SEPARADORES AGUA COMBUSTIBLE

KIT FILTROS DE 21 MICRON PARA MOTORES CARBURACIÓN



TIPO KIT	REF #	CAPACIDAD DE FILTRADO	CONTIENE
1/4" Aluminio (Filtro corto)	18-7848-1 / 508522	21	1 - 18-7844 filtro & 1 18-7853-1 soporte 2 - 18-4256 1/4" TAPONES
1/4" ALUMINIO BONUS PACK FILTRO DE REPUESTO	18-7848-2	21	2 - 18-7844 FILTRO & 1 18-7853-1 SOPORTE 2 - 18-4256 1/4" TAPONES
1/4" ALUMINIO (FILTRO ALTO) FILTRO DE REPUESTO	18-7852-1	21	1 - 18-7845 FILTRO & 1 18-7853-1 SOPORTE 2 - 18-4256 1/4" TAPONES
3/8" ALUMINIO (FILTRO ALTO)	18-7775-1	21	1 - 18-7845 FILTRO & 1 18-7775 SOPORTE 2 - 18-4264 3/8" TAPONES
1/4" ACERO INOXIDABLE (FILTRO ALTO)	18-7777-1	21	1 - 18-7845 FILTRO & 1 18-7777 SOPORTE 2 - 18-4256 1/4" TAPONES
3/8" ACERO INOXIDABLE (FILTER ALTO)	18-7776-1	21	1 - 18-7845 FILTRO & 1 18-7776 SOPORTE 2 - 18-4264 3/8" TAPONES

- DISEÑO UNIVERSAL-
RECAMBIO DIRECTO PARA MERCURY Y YAMAHA

SOPORTE SEPARADOR DE COMBUSTIBLE/AGUA



Soporte tipo	Ref #
1/4" acero inox	18-7777
3/8" acero inox	18-7776



Soporte tipo	Ref #
1/4" Aluminio	18-7853-1
3/8" Aluminio	18-7775



**KITS DE FILTRO DE 10 MICRONES
PARA MOTORES
DE INYECCIÓN DE COMBUSTIBLE**



TIPO KIT	Ref #	Micrones	Contenido
1/4" Aluminio (filtro corto)	18-7983-1	10	1 - 18-7944 filtro & 1 18-7853-1 soporte 2 - 18-4256 1/4" tapones
1/4" pack aluminio contiene filtro recambio	18-7983-2	10	2 - 18-7944 filtro & 1 18-7853-1 soporte 2 - 18-4256 1/4" tapones
1/4" Aluminio (filtro largo)	18-7982-1	10	1 - 18-7945 filtro & 1 18-7853-1 soporte 2 - 18-4256 1/4" tapones
1/4" Pack aluminio Contiene filtro recambio	18-7982-2	10	2 - 18-7945 filtro & 1 18-7853-1 soporte 2 - 18-4256 1/4" tapones
1/4" Aluminio (Filtro alta capacidad)	18-7966-1	10	1 - 18-7866 filtro & 1 18-7853-1 soporte 2 - 18-4256 1/4" tapones
3/8" Aluminio (filtro largo)	18-7986-1	10	1 - 18-7945 filtro & 1 18-7775 soporte 2 - 18-4264 3/8" tapones
1/4" Acero inox (filtro largo)	18-7984-1	10	1 - 18-7945 filtro & 1 18-7777 soporte 2 - 18-4256 1/4" tapones
3/8" Acero (filtro largo)	18-7985-1	10	1 - 18-7945 filtro & 1 18-7776 soporte 2 - 18-4264 3/8" tapones



KITS FILTROS DE 10 MICRAS CON CAZOLETA DE DRENAJE

Sierra AquaVue™ permiten el drenaje y alargan la vida útil del filtro. Use the AquaVue™ para fueraborda, instalaciones sobre cubierta. USCG requiere el uso de la cazoleta metálica debajo de la cubierta.

Tipo kit	Ref #	Micrones	Contenido
1/4" Aluminio con cazoleta Aqua-Vue™	18-7932-1	10	1 - 18-7919 filtro & 1 18-7853-1 soporte 1 - 18-7922-1 AquaVue™ cazoleta 2 - 18-4256 1/4" tapones
1/4" Aluminio cazoleta metálica	18-7951	10	1 - 18-7919 filtro & 1 18-7853-1 soporte 1 - 18-7924 cazoleta metálica 2 - 18-4256 1/4" tapones
1/4" Acero inox con cazoleta Aqua-Vue™	18-7937-1	10	1 - 18-7919 filtro & 1 18-7777 soporte 1 - 18-7922-1 AquaVue™ cazoleta 2 - 18-4256 1/4" tapones
1/4" Acero inox con cazoleta metálica	18-7938	10	1 - 18-7919 filtro & 1 18-7777 soporte 1 - 18-7924 cazoleta metálica 2 - 18-4256 1/4" tapones

SOPORTE Y KIT - PARA APLICACIONES EN PEQUEÑOS FUERABORDAS Y AGUA DULCE

18-7774
SOPORTE DE ALUMINIO COMPACTO



18-7965-1
KIT SEPARADOR
COMPACTO 10 MICRAS

Contiene:
1 - 18-7774 soporte
1 - 18-7865 filtro



FILTROS DE RECAMBIO



DISEÑO UNIVERSAL

FILTROS RECAMBIO 10 MICRAS

FILTROS RECAMBIO 21 MICRAS

Ref No.	Descripción	Ref No.	Descripción
18-7944	Corto - 3.875"	18-7844	corto - 3.875"
18-7945	Largo - 4.35"	18-7845	Largo - 4.35"
18-7866	Gran capacidad - 6"		
18-7865	Compacto 10 Micras		

FILTRO DE RECAMBIO PARA OMC

FILTROS RECAMBIO 10 MICRAS

RECAMBIO FILTROS 21 MICRAS

Ref No.	Descripción	Reemplaza	Part No.	Descripción	Reemplaza
18-7946	OMC rosca	OMC 502905	18-7846	OMC rosca	OMC 502905
18-7989	Cobra EFI	OMC 502906	18-7789	Cobra EFI	OMC 502906



FILTROS DE RECAMBIO DE 10 MICRAS Y KITS CON CAZOLETAS

FILTRO RECAMBIO

KITS FILTROS Y CAZOLETAS

Ref No.	Descripción	Reemplaza	Ref No.	Descripción
18-7919	Recambio	Racor S3213	18-7928-1	Filtro & cazoleta AquaVue™ Contiene: 18-7919 filtro, cazoleta 18-7922-1
18-7920	Recambio	OMC 502906 Racor S3214	18-7929	Filtro & cazoleta metálica Contiene: 18-7919 filtro, cazoleta 18-7924
			18-7941-1	Filtro & cazoleta AquaVue™ contiene: 18-7920 filtro, cazoleta 18-7922-1
			18-7943	Filtro & Cazoleta metálica Contiene: 18-7920 filtro, cazoleta 18-7924

CAZOLETA RECAMBIO

Ref No.	Descripción
18-7922-1	Cazoleta AquaVue™
18-7924	Cazoleta metálica



**18-79781
FILTRO COMB.**
Reemplaza: 433190
60° V4 y V6



**18-7953
FILTRO COMB.**
Reemplaza: 5035974
Para: 25HP (2006-07) / 90,115,140
4 tiempos (2005-06)



**18-7716
FILTRO COMB**
Reemplaza: 5032323
Para: Johnson 25 4-tiempos (2004-05),
30 4-tiempos (2004-07), 40/60/70
4-tiempos (2002-06), 90/115/140
4-tiempos (2003-04, 2006), Evinrude
25/30/40/50/70 4-tiempos (2000-01)



**18-7719
FILTRO COMB.**
Reemplaza: 5032238
Para: Johnson 4/5 (2003-07), 6
4-tiempos (2005-07), 10/15 4-tiempos
(2002-07),
40/50/60/70 4-tiempos (2002-06), Evin-
rude 40/50 4-tiempos (2000-01)



**18-7722
FILTRO COMB.**
• 3/8"
Reemplaza: 5005266
Para: E-Tec 40, 50, 60, 75, 90,115, 150, 175 & 200DPL



**18-7826
FILTRO COMB**
Reemplaza: 305185



Filtro combustible en línea

Ref No.	Aplicación
18-7828-1	1/4" pequeña capacidad (Para 1/4" línea comb)
18-7829	1/4" Gran capacidad (Para 1/4" línea comb)
18-7830	5/16" Reemplaza: OMC 398327
18-7831	3/8" Reemplaza: OMC 398319

Sistema combustible
JOHNSON / EVINRUDE (OMC/BRP)

LÍNEAS DE COMBUSTIBLE LONGITUD 8'

SILVERADO 4000 Premium

OE# 398549

Sin conectores

112356 - 8x13

112358 - 8x13

112351 - 7x12

112355 - 7x12

Longitud: 2 mts

Longitud: 3 mts

Longitud: 2 mts

Longitud: 3 mts



18-8063
CONECTOR
DEPÓSITO
(SE VENDE POR SEPARADO)



18-8092
CONECTOR
COMBUSTIBLE

18-8005S
BOMBA
MANUAL

18-8092
CONECTOR
COMBUSTIBLE



COMPONENTES DE LA LÍNEA DE COMBUSTIBLE
Para: 2 HP (1 cil.) - 75 HP (3 cil.) (1976-02)

3/8"
LÍNEA DE COMB.

18-8014EP-1 SILVERADO 4000 Premium

OE# 174509



18-8074
CON. DE MANGUERA
(SE VENDE POR SEPARADO)



18-8005S
BOMBA
MANUAL

18-8092
CONECTOR
COMBUSTIBLE



COMPONENTES DE LA LÍNEA DE COMBUSTIBLE
Para: Todos V6 & V8 (1976-02)



18-8004 5/16"
112350 (8mm)
BOMBA MANUAL
Reemplaza: 174511, 775638
Bomba gran capacidad



18-8005S 3/8"
112352 (8-10mm)
BOMBA MANUAL
Reemplaza: 174512
Bomba gran capacidad



APLICACIÓN CON. DE MANGUERA

FILTROS COMB EN LÍNEA

Ref No.	OMC No.	Barb	NPT	Con. Tipo
18-8055	173311	5/16"	1/4"	M
18-8074	173312	3/8"	1/4"	M



18-8056
18-8056-10
CONECTOR COMB
5/16"
Reemplaza: 174508, 775640
Se acopla con 18-8063



18-8063
18-8063-10
CONECTOR TANQUE
Reemplaza: 502867, 772681
(1/4" NPT)
Se acopla con 18-8056 & 18-8092



18-8072
CODO COMBUSTIBLE
3/8" conexión con 3/8"
Reemplaza: 174177
90°



18-8092
CONECTOR COMBUSTIBLE
3/8"
Reemplaza: 176445, 775641
Se acopla con 18-8063



18-3290
CODO INDICADOR
Reemplaza: 321886
Rosca de manguera



MANGUERA DE SANGRADO
18-8048 **18-8050**
.090 D.I. x .220 D.E. .0625 D.I. x .190 D.E.



18-8051
MANGUERA COMBUSTIBLE DOBLE
1/8" D.I.
Reemplaza: 322656
Para Sistemas Presurizados OMC



18-8052
MANGUERA COMBUSTIBLE
3/16" D.I.
Reemplaza: 122838
No-Sistemas Presurizados



SAE J1527 USCG Type B1-15 SILVERADO 4000

16-337-0560
5/16" D.I.

16-337-0380
3/8" D.I.

Disponibles bobinas 50'.

* Tanques y motores sólo a modo ilustrativo.

Ⓛ Pack de 10 - Precio por envase

**PURE FUEL DELIVERS PURE
PERFORMANCE**



SIERRA FILTERS

INDUSTRY LEADER IN 10-MICRON TECHNOLOGY



Increased levels of engine sophistication, coupled with ethanol fuel blends, necessitate the use of a high quality fuel filter. Sierra filters are engineered to offer the ultimate in filtration, separation of water from the fuel supply and provide maximum fuel flow.

www.seastarsolutions.com



SEASTAR
SOLUTIONS®



18-9125
KIT ABRAZADERA
Reemplaza: 787133, 787145

Ref #	Cant	Johnson/Evinrude #	Oetiker #	Descripción	
18-9141	1	787145	14100082	kit abrazaderas	
Nominal D.E					
Ref #	Cant	Johnson/Evinrude #	Oetiker #	Pulgadas	mm
18-9126-9	10	346930	16700004	3/8"	9.5
18-9127-9	10	348838	16700006	13/32"	10.5
18-9128-9	10	349516	16700007	7/16"	11.3
18-9129-9	10	347107	16700010	1/2"	13.3
18-9130-9	10	347108	16700011	17/32"	13.8
18-9131-9	10	346931	16700012	35/64"	14
18-9132-9	10	346785	16700013	9/16"	14.5
18-9133-9	10	346786	16700016	5/8"	15.7
18-9134-9	10	348839	16700017	11/16"	17
18-9135-9	10	346151	16700024	13/16"	21
18-9136-9	10	346152	16700031	1"	25.6
18-9137-9	10	346153	16700037	1 3/16"	30.1
18-9138-9	10	349759	16700040	1 1/4"	31.6
18-9139-9	10	349729	16700053	1 5/8"	41
18-9140-9	10	346150	16700020	23/32"	18.5

Las abrazaderas vienen en envase de 10 y cada envase está disponible individualmente

Pack. de 10



ABRAZADERAS

Ref No.	Ref. O.E. No.	Gama	Talla
① 18-8020	322652	.538 - .608	8
① 18-8021	911616	.597 - .665	10
① 18-8034	329654	.670 - .780	12
① 18-8200	322653	.360 - .406	2
① 18-8201	124249	.410 - .468	4
① 18-8202	322654	.475 - .536	6
① 18-8203*	329653	.750 - .875	14
① 18-8204*	324825	.875 - .975	19



18-8905
KIT REPARACION IMPULSOR
Reemplaza: 5008968
Para: 15 (AA-AF), 25 (AA-AF), 30(AA-AF)



18-3001
IMPULSOR
Reemplaza: 277181, 434424



18-3002
IMPULSOR
Reemplaza: 375638, 775518



18-3003
IMPULSOR
Reemplaza: 377178, 775519



18-3006
IMPULSOR
Reemplaza: 378891, 775521

18-3015 CEF
18-3015S
IMPULSOR
Reemplaza: 396852, 433935, 797407
Con llave
Para: 2.5, 3, 4 Ultra, Excel



18-3043
IMPULSOR
Reemplaza: 389642



18-3044
IMPULSOR
Reemplaza: 385072



18-3050 CEF
18-3050S
IMPULSOR
Reemplaza: 386084



18-3051 CEF
18-3051S
IMPULSOR
Reemplaza: 395289

① Precio por pieza. Para pedir precio por envase añadir -9 a la referencia.

APLICACIONES IMPULSORES COMIENZAN EN LA PÁGINA 171

 <p>18-3053-1 IMPULSOR Reemplaza: 396725 Llave de cuña</p>	 <p>18-3055 IMPULSOR Reemplaza: 389589</p>	 <p>18-3059 18-3059-10^① IMPULSOR Reemplaza: 381538, 389289, 394534, 395864, 397131, 435821, 435748, 439948, 5001593 Incluye 18-3299 Llave impulsora</p>	 <p>18-3082 IMPULSOR Reemplaza: 382547 Llave ranura</p>
 <p>18-3083 CEF 18-3083S IMPULSOR Reemplaza: 377230, 777213</p>	 <p>18-3090 IMPULSOR Reemplaza: 387361, 763735</p>	 <p>18-3091 IMPULSOR Reemplaza: 389576</p>	 <p>18-3099 IMPULSOR Reemplaza: 5033112 Para: 4 tiempos 9.9 y 15 HP (2002-sup)</p>
 <p>18-3104-1 IMPULSOR Reemplaza: 432941, 437059, 765350</p>	 <p>18-3366 IMPULSOR Reemplaza: 390286</p>	 <p>18-3368 IMPULSOR Reemplaza: 396809</p>	 <p>18-45312 IMPULSOR Reemplaza: 114812 Para: J/E 2(1993-99), 3(1991-99)</p>
 <p>18-45221 IMPULSOR Reemplaza: 382221 Para: Johnson Evinrude 1.5/2 hp (1967-84)</p>	 <p>18-3096 IMPULSOR Reemplaza: 5031417 Para: 25-30 HP (2000-01, 2004-07), 40-50 HP (1999-006)</p>	 <p>18-8906 IMPULSOR Reemplaza: 3436137 Para: 5 HP (1996-98), 6-8 HP (1991- 2005)</p>	 <p>18-4539 IMPULSOR Reemplaza: 5008967 Para: 15 (AA-AF), 25 (AA-AF), 30 (AA-AF)</p>
 <p>18-8907 IMPULSOR Reemplaza: 5033542 Para: 90, 115, 140 (2003-06)</p>	 <p>18-3102 IMPULSOR PLATINA Reemplaza: 305303</p>	 <p>18-3103 IMPULSOR PLATINA Reemplaza: 303069</p>	 <p>18-3127 IMPULSOR PLATINA Reemplaza 319275</p>

APLICACIONES COMIENZAN EN LA PÁGINA 171

① Pack de 10- Precio por pack

18-3182
IMPULSOR PLATINA
Reemplaza: 317841



18-3346
ALOJAMIENTO Y PLATINA
IMPULSOR
Reemplaza: 435027



18-3359
PLATINA IMPULSOR
Reemplaza: 328755



18-3179
CASQUILLO BOMBA AGUA
Reemplaza: 324097



18-3455
CASQUILLO BOMBA DE AGUA
Reemplaza: 340619
Para: 40, 50, 25 Jet, 30 Jet 1995-sup,
E-Tec 40/50/60 HP todos



Llave impulsora

Ref No.	Reemplaza	Std. Pkg
18-3295 ③	330619, 344470	3
18-3138 ①③	334897	2
18-3108	308928	1
18-3299 ③	331107	5
18-3326	300611	1

① Pack de 2 ② Pack de 3

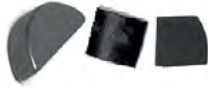

18-3501
DIAFRAGMA &
ENSAMBLAJE
Reemplaza: 435957
Para: 8 (1996-97), 10 (1996-97), 15 (1996-97),
40 (1995-97), 50 (1995-97), 55 (1995-97),
60 (1993-96), 65 (1993-96), 70 (1993-96),
120 (1993-94), 125 (1993-95), 130 (1995-96),
140 (1993-94), 250 (1994-95), 300 (1994-95)



18-3358
CASQUILLO BOMBA DE AGUA
Reemplaza: 328751



18-3129
BOMBA AGUA ALOJAMIENTO
Reemplaza: 435673, 438591,
436954, 432955



18-3405
BOMBA AGUA ALOJAMIENTO
Reemplaza: 435959



18-3180
BOMBA AGUA ALOJAMIENTO
Reemplaza: 435390



18-3336
BOMBA AGUA ALOJAMIENTO
Reemplaza: 384087



18-3363
BOMBA AGUA ALOJAMIENTO
Reemplaza: 330560



18-4568
ALOJAMIENTO IMPULSOR
Reemplaza: 5007554
Para: 90 (2013 Y Sup), 115/130
(2009 Y Sup)



18-4569
ALOJAMIENTO IMPULSOR
Reemplaza: 339720



18-4571
ALOJAMIENTO IMPULSOR
Reemplaza: 360347
Para: 200-300 HP (2009Y Sup)



18-3367
BOMBA AGUA ALOJAMIENTO
Reemplaza: 393632



18-3126
PLATINA DESGASTE
Reemplaza: 321940



18-3178
PLATINA DESGASTE
Reemplaza: 318995



18-3343
PLATINA DESGASTE
Reemplaza: 320981



APLICACIONES EMPIEZAN EN LA PÁGINA 171

③ Precio por producto. Para precio por envase poner-9 en la referencia.



18-3201
KIT REPARACIÓN IMPULSOR
Reemplaza: 379763

— CONTIENE —

Ref #	Desc.	O.E. #	Cant.
18-3001	Impulsor	277181, 434424	1
NSS	Platina	203132	1



18-3202
KIT REPARACIÓN IMPULSOR

— CONTIENE —

Ref #	Desc.	O.E. #	Cant.
18-3001	Impulsor	277181, 434424	1
18-3102	Impulsor platina	305303	1



18-3203
KIT REPARACIÓN IMPULSOR
Reemplaza: 379766, 379766

— CONTIENE —

Ref #	Desc.	O.E. #	cant.
18-3002	Impulsor	375638	1
18-3103	Impulsor platina	303069	1

①18-3211D



18-3211
KIT REPARACIÓN IMPULSOR

— CONTIENE —

Ref #	Desc.	O.E. #	Cant.
18-3059	Impulsor	395864, 397131, 435821	1
18-2536	Retén goma	321120	1
18-2557	Junta impulsor	324701, 338484	1
18-3299	Llave impulsora	331107	1
18-7158	Aro	310967, 310585	1
18-3138	llave impulsora	334897	1

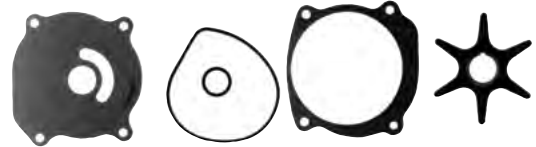

18-3210
KIT REPARACIÓN IMPULSOR

— CONTIENE —

Ref #	Desc.	O.E. #	Cant.
18-3043	Impulsor	389642	1
18-2536	Retén goma	321120	1
18-2557	Junta impulsor	324701, 338484	1
18-7158	Aro	310967, 310585	1



18-3453
KIT BOMBA AGUA

Con alojamiento

Reemplaza: 5006511

Para: E-Tec 40/50/60 HP Todos



18-3454
KIT BOMBA AGUA

con alojamiento

Reemplaza: 438592

Para: 40, 50, 25 Jet, 30 Jet 1995-sup

Incluye impulsor 18-3104-1



18-3325
KIT BOMBA AGUA
Reemplaza: 387326

— CONTIENE —

Ref #	Desc.	O.E. #	Cant.
18-7134	Aro tórico	339543	1
18-3108	Llave	308928	1
18-3337	Casquillo	315837	1
18-3083	Impulsor	377230	1
18-3343	Impulsor platina	320981	1
18-2705	Casquillo	315748	1



18-3327
KIT BOMBA AGUA

con alojamiento

Reemplaza: 394711, 386697, 391698, 389112, 387610

— CONTIENE —

Ref #	Desc.	O.E. #	Cant.
18-3050	Impulsor	386084	1
18-3180	Alojamiento	435390	1
18-3178	Platina desgaste	318995	1
18-3179	Casquillo bomba de agua	324097	1
18-3329	Casquillo	302497	1
18-2392	Casquillo	327035	1
18-2025	Retén aceite	318972	1
18-7116	Aro	303097	1
18-7139	aro	319085	1
18-3326	Pin	300771	1
18-3369	Tornillo acero inox	319126	4

APLICACIONES EMPIEZAN EN LA PÁGINA 171

① referencias acabadas en "D" envasadas

**18-3378
KIT BOMBA AGUA**

con alojamiento
Reemplaza: 391635, 439077

— CONTIENE —

Ref #	Desc.	O.E. #	Cant.
18-3055	Impulsor	389589	1
18-3343	Impulsor platina	320981	1
18-3336	Alojamiento	384087	1
18-2709	Junta platina desgaste	336530	1
18-3365	Tornillo acero inox	909533	2
18-3369	Tornillo acero inox	319126	2
18-2705	Retén	315748	1
18-3337	Casquillo tubo de agua	315837	1
18-7134	Aro tórico	303059	1

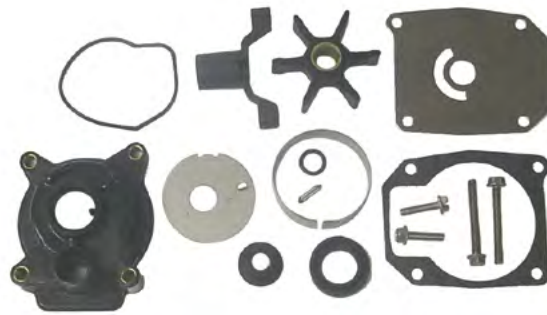

**18-3376
KIT BOMBA AGUA**

Sin alojamiento
Reemplaza: 384956

— CONTIENE —

Ref #	Desc.	O.E. #	Cant.
18-3083	Impulsor	377230	1
18-3343	Impulsor platina	320981	1
18-3108	llave	308928	1
18-3337	Casquillo	315837	1
18-7134	Aro tórico	39543	1
18-2705	Casquillo	315748	1
18-3136	tornillo (largo)	324430	2
18-3369	Tornillo acero inox	319126	2



**18-3377
KIT BOMBA AGUA**

Sin alojamiento
Reemplaza: 382468

— CONTIENE —

Ref #	Desc.	O.E. #	Cant.
18-3002	Impulsor	375638	1
18-3103	Impulsor platina	303069	1
18-3329	Casquillo tubo de agua	302497	1
18-3326	Pin	300771	1



**18-3379
KIT BOMBA AGUA**

Sin alojamiento
Reemplaza: 390381

— CONTIENE —

Ref #	Desc.	O.E. #	Cant.
18-3366	Impulsor	390286	1
18-3352	Impulsor platina	325398	1
18-3354	Junta bomba agua	325399	2
18-3332	Casquillo	304056	1



**18-3380
KIT BOMBA AGUA**

Sin alojamiento
Reemplaza: 390770

— CONTIENE —

Ref #	Desc.	O.E. #	Cant.
18-3055	Impulsor	389589	1
18-3343	Impulsor platina	320981	1
18-2709	Junta platina desgaste	336530	1
18-3365	Tornillo acero inox	909533	2
18-3136	Tornillo acero inox	319126	2
18-2705	Retén	315748	1
18-3337	Casquillo tubo de agua	315837	1
18-7134	Aro tórico	303059	1



**18-3381
KIT BOMBA AGUA**

Sin alojamiento
Reemplaza: 393509

— CONTIENE —

Ref #	Desc.	O.E. #	Cant.
18-3051	Impulsor	395289	1
18-3359	Impulsor platina	328755	1
18-0124	Junta impulsor platina	325537	1
18-3358	Tapa bomba agua	328751	1
18-2539	Retén goma	328753	1
18-3329	Casquillo	302497	1
18-7100	Aro tórico	301877	1
18-7105	Aro tórico	311338	2
18-7146	Aro tórico	554545	1
18-3133	Tornillo acero inox	331979	6



**18-3382
KIT BOMBA AGUA**

Con alojamiento
Reemplaza: 393630

— CONTIENE —

Ref #	Desc.	O.E. #	Cant.
18-3051	Impulsor	395289	1
18-3359	Impulsor platina	328755	1
18-3367	Alojamiento	393632	1
18-3358	Tapa bomba agua	328751	1
18-0124	Junta impulsor platina	325537	1
18-3329	Casquillo	302497	1
18-7100	Aro	301877	1
18-7105	Aro	311338	2
18-7146	Aro	554545	1
18-3133	Tornillo acero inox	331979	6





**18-3383
KIT BOMBA AGUA**

Con alojamiento

Reemplaza: 395270

-- CONTIENE --

Ref #	Desc.	O.E. #	Cant.
18-3051	Impulsor	395289	1
18-3363	Alojamiento	330560	1
18-3358	Tapa bomba agua	328751	1
18-3360	Junta impulsor alojamiento	329390	1
18-3329	Casquillo	302497	1
18-3133	Tornillo acero inox	331979	4



**18-3384
KIT BOMBA AGUA**

Sin alojamiento

Reemplaza: 386124

-- CONTIENE --

Ref #	Desc.	O.E. #	Cant.
18-7158	Aro	310585	1
18-3108	Llave	308928	1
18-3043	Impulsor	389642	1
18-3182	Impulsor platina	317841	1
18-2026	Retén aceite	321453	1
18-3135	Tornillo	306643	2
18-3136	Tornillo	323626	4
18-2389	Casquillo	314832	2



**18-3385
KIT BOMBA AGUA**

Sin alojamiento

Reemplaza: 396932

-- CONTIENE --

Ref #	Desc.	O.E. #	Cant.
18-3368	Impulsor	396809	1
18-3343	Impulsor platina	320981	1
18-2705	Retén	315748	1
18-7481	Goma retén	324981	1
18-7134	Aro tórico	303059	1
18-3337	Casquillo tubo de agua	315837	1
18-3365	Tornillo acero inoxidable	909533	2
18-3369	Tornillo acero inoxidable	319126	2



**18-3387
KIT BOMBA AGUA**

Sin alojamiento

Reemplaza: 432956

-- CONTIENE --

Ref #	Desc.	O.E. #	Cant.
18-2703	Casquillo	314008	1
18-3053-1	Impulsor	396725	1
18-2705	Retén	315748	1
18-3133	Tornillo	331979	4
18-7174	Aro tórico	326649	1
18-7481	Aro tórico	324981	1
18-2709	Junta platina desgaste	336530	1
18-3126	Platina desgaste	321940	1
18-3127	Impulsor platina	319275	1
18-3138	Chaveta	334897	1
18-3299	Llave	331107	1
18-3153	Tornillo acero inoxidable	908158	1



**18-3388
KIT BOMBA AGUA**

Sin alojamiento

Reemplaza: 386533, 389143

-- CONTIENE --

Ref #	Desc.	O.E. #	Cant.
18-0969	Junta alojamiento impulsor	319586	1
18-3108	Llave acero inoxidable	323950	1
18-2703	Casquillo	314008	1
18-3127	Impulsor platina	319275	1
18-2705	Retén	315748	1
18-3082	Impulsor	382547	1
18-3153	Tornillo acero inox	334597	1
18-2709	Junta platina desgaste	336530	1
18-3133	Tornillo acero inoxidable	331979	4
18-3126	Platina desgaste	321940	1



**18-3389
KIT BOMBA
COMBUSTIBLE**

Con alojamiento

Reemplaza: 436957

-- CONTIENE --

Ref #	Desc.	O.E. #	Cant.
18-7481	Aro tórico	324981	1
18-2703	Casquillo	314008	1
18-3053-1	Impulsor	396725	1
18-3127	Impulsor platina	319275	1
18-2705	Retén	315748	1
18-3133	Tornillo acero inox	908158	1
18-3299	Llave	331107	1
18-7174	Aro tórico	326649	1
18-2709	Junta platina desgaste	336530	1
18-3129	Alojamiento	435673	1
18-3138	Chaveta	334897	1
18-3126	Platina desgaste	321940	1



18-3390
KIT BOMBA AGUA
Sin alojamiento
Reemplaza: 395060

— CONTIENE —

Ref #	Desc.	O.E. #	Cant.
18-3059	Impulsor	397131, 435821	1
18-2557	Junta impulsor	324701, 338484	1
18-3299	Chaveta	331107	1
18-7158	Aro tórico	310967, 310585	1
18-3135	Tornillo acero inoxidable	306643	2
18-2703	Casquillo	314008	1
18-2704	Casquillo	320943	1
18-2706	Casquillo	321008	1
18-3136	Tornillo acero inox	323626	4
18-2769	Goma retén	332000	1
18-3133	Tornillo acero inoxidable	331979	4
18-3346	Tapa acoplamiento platina.	435027	1
18-3138	Llave impulsor	334897	1



18-3391
KIT BOMBA AGUA
Con alojamiento
Reemplaza: 395072

— CONTIENE —

Ref #	Desc.	O.E. #	Cant.
18-3346	Tapa y acoplamiento platina.	435027	1
18-2769	Aro tórico	332000	1
18-2557	Junta platina impulsor	338484, 324701	1
18-2704	Casquillo	320943	1
18-3136	Tornillo acero inoxidable	323626	4
18-3299	Llave	331107	1
18-3153	Tornillo acero inox	908158	1



18-3392
KIT BOMBA AGUA
Con alojamiento
Reemplaza: 434421

— CONTIENE —

Ref #	Desc.	O.E. #	Cant.
18-3059	Impulsor	395864, 397131, 435821	1
18-3346	Tapa y acoplamiento platina.	435027	1
18-3299	Chaveta	331107	1
18-7158	Aro tórico	310967, 310585	1
18-3135	Tornillo acero inox	306643	2
18-2703	Casquillo	314008	1
18-2704	Casquillo	320943	1
18-2706	Casquillo	321008	1
18-3136	Tornillo acero inox	323626	4
18-2769	Goma retén	332000	1
18-2557	Junta impulsor	324701, 338484	1
18-3133	Tornillo acero inox	331979	4



18-3393
KIT BOMBA AGUA
Con alojamiento
Reemplaza: 395073, 388644

— CONTIENE —

Ref #	Desc.	O.E. #	Cant.
18-3043	Impulsor	389642	1
18-2557	Junta impulsor	324701, 338484	1
18-3346	tapa y acoplamiento platina.	435027	1
18-3108	Llave bomba de agua	323950	1
18-0110	Junta alojamiento	324670	1
18-7158	Aro tórico	310967, 310585	1
18-3135	Tornillo acero inox	306643	2
18-2703	Casquillo	314008	1
18-2704	Casquillo	320943	1
18-2706	Casquillo	321008	1
18-3136	Tornillo acero inox	323626	4
18-2769	Aro tórico	332000	1
18-7143	Aro tórico	322501	1
18-3133	Tornillo acero inox	331979	4



18-3394
KIT BOMBA AGUA
Sin alojamiento
Reemplaza: 433548

— CONTIENE —

Ref #	Desc.	O.E. #	Cant.
18-7481	Aro tórico	324981	1
18-2708	Casquillo	333758	1
18-2709	Junta platina desgaste	336530	1
18-3104-1	Impulsor	432941	1
18-3138	Chaveta	334897	1
18-2705	Retén	315748	1
18-3133	Tornillo acero inox	331979	4
18-3126	Platina desgaste	321940	1



18-3399
KIT BOMBA AGUA
Con alojamiento
Reemplaza: 396933

— CONTIENE —

Ref #	Desc.	O.E. #	Cant.
18-7134	Aro tórico	303059	1
18-3337	Casquillo	315837	1
18-3368	Impulsor	396809	1
18-2709	Junta platina desgaste	336530	1
18-3369	Tornillo (Corto)	319126	2
18-2705	Retén	315748	1
18-3336	Alojamiento	384087	1
18-3365	Tornillo (Largo)	909533	2
18-3343	Platina desgaste	320981	1

18-3400
KIT BOMBA AGUA
Sin alojamiento
Reemplaza: 391698



— CONTIENE —

Ref #	Desc.	O.E. #	Cant.
18-3050	Impulsor	386084	1
18-3178	Impulsor platina	318995	1
18-3179	Tapa bomba de agua	324097	1
18-3329	Casquillo	302497	1
18-2392	Casquillo	327035	1
18-2025	Retén aceite	318972	1
18-7116	Aro tórico	303097	1
18-3369	Tornillo	319126	4
18-3326	Pin	300771	1
18-7139	Aro tórico	319085	1

18-3401
KIT BOMBA AGUA
Sin alojamiento



Reemplaza: 395271, 394394

— CONTIENE —

Ref #	Desc.	O.E. #	Cant.
18-3051	Impulsor	395289	1
18-3360	Junta	329398	1
18-3358	Tapa	328773	1
18-7440-1	Aro tórico	301967	2
18-2013	Retén aceite	321786	1
18-3329	Casquillo	302497	1
18-0108	Junta	324449	1
18-3133	Tornillo acero inox	331979	4

18-3402
KIT BOMBA AGUA
Sin alojamiento
Reemplaza: 382296



— CONTIENE —

Ref #	Desc.	O.E. #	Cant.
18-3003	Impulsor	377178	1
18-3102	Impulsor platina	305303	1
18-2891	Junta	303339	1
18-3326	Pin	300771	1
18-3329	Casquillo	302497	1
18-2023	Retén aceite	313282	1

18-3403
KIT BOMBA AGUA
SIN ALOJAMIENTO
Reemplaza: 388644



— CONTIENE —

Ref #	Desc.	O.E. #	Cant.
18-7158	Aro tórico	310585	1
18-3108	Llave	308928	1
18-2703	Casquillo	314008	1
18-3135	Tornillo	306643	4
18-2026	Retén	321453	1
18-3136	Tornillo alojamiento	323626	1
18-3043	Impulsor	389642	1
18-3346	Tapa y acomplamiento platina	435027	1
18-2536	Junta	321120	1
18-2704	Casquillo	320943	1

18-3315-2
KIT BOMBA AGUA

Con alojamiento
Reemplaza: 435929, 5001595
Para: 90/115SL (1995-SUP), 120/125ESX (1993-94), 120/130/140/150/175V-6/V-8 (1993-SUP)



— CONTIENE —

Ref #	Desc.	O.E. #	Cant.
18-2557	Junta	324701	1
18-3405	Alojamiento, WP	435485	1

TORNILLOS ACERO INOXIDABLE

Ref No.	O.E. #	Tamaño
18-3133	330619, 344470	1/4 x 20 x 11/16"
18-3135 ①③	306643	1/8 x 20 x 1/2"
18-3136 ①③	323626	1/4 x 20 x 13/4"
18-3153	908158	1/4 x 20 x 1/2"
18-3365	909533	1/4 x 20 x 1"
18-3369	319126	1/4 x 20 x 1"
18-4276 ②③	324334	1/4 x 20 x 1 1/32"

① Envase estandar de 2 ② Envase estandar de 5

APLICACIONES EMPIEZAN EN LA PÁGINA 171

③ Precio por pieza. Para pedir precio por envase -9 a la referencia.



18-4537
KIT BOMBA AGUA
 Reemplaza: 5008972
 Para: 15 (AA-AF), 25 (AA-AF), 30 (AA-AF)



18-3472
KIT BOMBA AGUA
 Reemplaza: 5007972
 Para: 200-300 HP (2009Y Sup)



18-3476
KIT BOMBA AGUA
 Reemplaza: 5007556
 Para: 90 (2013-Sup), 115/130 (2009-Sup)



18-3491
KIT BOMBA AGUA
 Reemplaza: 437907
 Para: 25/35 (1996-01)



18-4529
KIT BOMBA AGUA
 Reemplaza: 396644
 Para: 4 HP (1986-92), 5 HP (1980-83, 1996-01), 6 HP (1984-01, 2003-05), 8 HP (1980-01, 2003-05)



TABLA EQUIVALENCIA TURBINA EVINRUDE

MOTOR EVINRUDE / JOHNSON	REFERENCIA EVINRUDE / JOHNSON	PRONAUTIC
2,5, 3,5, 4 ultra exel	396852, 433935, 767407	18-3015
9.9/15 (4 y 2-tiempos)	386084	18-3050
3, 4, 5, 5,5, 6, 7,5 (2 tiempos)	277181, 434424	18-3001
4, 6 (2 tiempos)	387361, 763735	18-3090
5, 6 , 8 (4 tiempos)	389576, 433914	18-3091
4, 5 (2 tiempos)	389576, 433914	18-3091
9,5, 10, (2 tiempos)	377178, 775519	18-3003
10, 15, 18, 25 28,	375638, 775518	18-3002
20, 25,28, 30, 35 mas modernos	395289	18-3051
35 jet, y 40, (1989-1998), y 48(1989-1996)	432941,437059, 765350	18-3104-1
40 (1984-85)	389589,777129	18-3055
40 (1986-88)	396809,777214	18-3368
40 (1999 y superiores)	389557,396725	18-3053-1
40 comm (1981-1990)	390286	18-3066
45, 55 y 48, y 50 (1.986-1988)	396809, 777214	18-3368
40,60, (1986 y superior), 65, 70,(1980 y superior) y 75	389557, 396725	18-3053-1
85, 90, 90 sl, di, 100, 115 y 115 sl,dl, 120	389289. 391538, 394534, 395864,	18-3059
125 esx, 130, 135, 140, 150, 175, 200, 225, 235 v4 y v6	397131, 435748, 435821, 439948	18-3059
135, 150, 175, 200, 235, motores antiguos	385528,389642,777212	18-3043

HP	Año	Impulsor	Impulsor platina	Platina y tapa	Tapa	Kit reparación	Kit bomba S/ aloj.	Kit bomba c/aloj.	Kit alojamiento
2 Jr, Colt	1985-90	18-3090	—	—	—	—	—	—	—
2.5	1987-06	18-3015	—	—	—	—	—	—	—
3	1952-78	18-3001	—	—	—	18-3201	—	—	—
3.5	1987-06	18-3015	—	—	—	—	—	—	—
4	1969-72	18-3001	—	—	—	18-3201	—	—	—
4 ①	1973-83	18-3001	—	—	—	18-3201	—	—	—
4 ②	1976-80	18-3090	—	—	—	—	—	—	—
4 Deluxe	1980-97	18-3091	—	—	—	—	—	—	—
4 Ultra Excel	1987-06	18-3015	—	—	—	—	—	—	—
4.5	1980-97	18-3091	—	—	—	—	—	—	—
5	1965-68	18-3001	—	—	—	—	—	—	—
5 (4-tiempos)	1998-sup	18-3091	—	—	—	—	—	—	—
5.5	1954-64	18-3001	18-3102	—	—	18-3202	—	—	—
6	1952-78	18-3001	18-3102	—	—	18-3202	—	—	—
6	1979	18-3090	—	—	—	—	—	—	—
6	1984-97	18-3091	—	—	—	—	—	—	—
6 (4-tiempos)	1998-sup	18-3091	—	—	—	—	—	—	—
7.5	1954-58	18-3001	18-3102	—	—	18-3202	—	—	—
8 (2-tiempos)	1986-97	18-3091	—	—	—	—	—	—	—
9.5	1964-73	18-3003	18-3102	—	—	—	18-3402	—	—
10	1958-63	18-3003	18-3102	—	—	—	18-3402	—	—
10	1949-57	18-3002	18-3103	—	—	18-3203	18-3377	—	—
9.9/15	1974-sup	18-3050	18-3178	—	18-3179	—	18-3400	18-3327	18-3180
9.9/15 (4-tiempos)	1995-sup	18-3050	18-3178	—	18-3179	—	18-3400	18-3327	18-3180
15,18	1953-65	18-3002	—	—	—	18-3203	18-3377	—	—
20	1966-73	18-3002	—	—	—	18-3203	18-3377	—	—
20	1982-84	18-3051	—	—	18-3358	—	18-3401	18-3383	18-3363
20	1985-sup	18-3051	18-3359	—	18-3358	—	18-3381	18-3382	18-3367
25	1951-55	18-3006	—	—	—	—	—	—	—
25	1969-78	18-3002	18-3103	—	—	18-3203	18-3377	—	—
25	1979-84	18-3051	—	—	18-3358	—	18-3401	18-3383	18-3363
25	1985-sup	18-3051	18-3359	—	18-3358	—	18-3381	18-3382	18-3367
28	1962-64	18-3006	—	—	—	—	—	—	—
28	1978-sup	18-3051	—	—	18-3358	—	18-3401	18-3383	18-3363
30	1951-57	18-3006	—	—	—	—	—	—	—
30	1984-sup	18-3051	18-3359	—	18-3358	—	18-3381	18-3382	18-3367
33	1962-71	18-3006	—	—	—	—	—	—	—
35	1951-57	18-3006	—	—	—	—	—	—	—
35	1958-59	18-3083	—	—	—	—	—	—	—
35	1976-77	18-3006	—	—	—	—	—	—	—
35	1978-79	18-3051	—	—	—	—	18-3238	—	—
35	1980-82	18-3051	N/A	—	18-3358	—	—	18-3382	18-3367
35	1983-sup	18-3051	18-3359	—	18-3358	—	—	—	—
35 Jet	1992-93	18-3104-1	—	—	—	—	18-3394	—	—
40	1960-70	18-3083	—	—	—	—	—	—	—
40	1971-73	18-3006	—	—	—	—	—	—	—
40 Comm.	1981-90	18-3366	18-3352	—	—	—	18-3379	—	—
40	1984-85	18-3055	18-3343	—	—	—	18-3385	18-3399	18-3336
40	1986-88	18-3368	18-3343	—	—	—	18-3385	18-3399	18-3336
40	1989-98	18-3104-1	—	—	—	—	18-3394	—	—
40	1999-sup	18-3053-1	—	—	—	—	18-3394	—	—

① Excepto bombas cromadas

② Excepto modelos SL 1995 y Sup/FFI

③ "S" Sufijo

④ "F" Sufijo

⑤ Excepto 1993-94 25" & 30" V6 & V8

⑦ Para bomba de agua de un solo tubo

⑧ Caja engranajes 90°

HP	Año	Impulsor	Impulsor platina	Platina y tapa	Tapa	Kit reparación	Kit bomba S/ aloj.	Kit bomba c/aloj.	Kit alojamiento
45/55 Comm.	1985	18-3055	—	—	—	—	18-3380	—	18-3336
45/55	1989	18-3368	18-3343	—	—	—	18-3385	18-3399	18-3336
45/55 Comm.	1986-88,	18-3368	—	—	—	—	18-3385	18-3399	18-3336
48	1987-88	18-3368	18-3343	—	—	—	18-3385	18-3399	18-3336
48	1989-96	18-3104-1	18-3127	—	—	—	18-3394	—	—
50	1971-78	18-3083	18-3343	—	—	—	18-3376	—	—
50	1979-85	18-3055	18-3343	—	—	—	18-3380	18-3378	18-3336
50	1986-88	18-3368	18-3343	—	—	—	18-3385	18-3399	18-3336
50	1989-98	18-3104-1	—	—	—	—	18-3394	—	—
55	1968-69	18-3082	—	—	—	—	—	—	—
55	1976-78	18-3083	—	—	—	—	—	—	18-3336
55	1979-85	18-3055	18-3343	—	—	—	18-3380	18-3378	18-3336
60	1964-67	—	—	—	—	—	—	—	—
60	1970-71	18-3082	—	—	—	—	—	—	—
60	1980-85	18-3055	—	—	—	—	18-3380	18-3378	18-3336
60	1986-94	18-3053-1	18-3127	—	—	—	18-3387	18-3389	—
60	1995-sup	18-3053-1	18-3127	—	—	—	18-3387	—	—
65	1968	—	—	—	—	—	—	—	—
65	1972-73	18-3082	—	—	—	—	—	—	—
65 Comm.	1984-94	18-3053-1	18-3127	—	—	—	18-3387	18-3389	—
65 Comm.	1995-sup	18-3053-1	18-3127	—	—	—	18-3387	—	—
70	1974-78	18-3082	18-3127	—	—	—	18-3388	—	—
70	1979-94	18-3053-1	18-3127	—	—	—	18-3387	18-3389	—
70	1995-sup	18-3053-1	18-3127	—	—	—	18-3387	—	—
75	1960-65	—	—	—	—	—	—	—	—
75	1974-78	18-3082	18-3127	—	—	—	18-3388	—	—
75	1979-88	18-3053-1	18-3127	—	—	—	18-3387	18-3389	18-3129
80	1966-67	—	—	—	—	—	—	—	—
85	1968	—	—	—	—	—	—	—	—
85	1969-72	18-3044	18-3182	—	—	—	—	—	—
85	1973-77	18-3043	18-3182	—	—	—	18-3384	—	—
85	1978	18-3043	—	18-3346	—	—	—	18-3393⑦	18-3391
85	1979-95	18-3059	—	18-3346	—	18-3211	18-3390	18-3392	18-3391
90	1964-68	—	—	—	—	—	—	—	—
90	1979-sup	18-3059	—	18-3346	—	18-3211	18-3390	18-3392②	18-3391
90 SL,DI	1995 & SUP	18-3059	—	18-3346	—	18-3211	18-3390	18-3315-2	18-3405
100	1969-72	18-3044	—	—	—	—	—	—	—
100	1979-sup	18-3059	—	18-3346	—	18-3211	18-3390	18-3392	18-3391
100 Comm. ①	1984-sup	18-3059	—	18-3346	—	18-3211	18-3390	18-3392	18-3391
105 Comm.	1998-2001	18-3059	—	18-3346	—	18-3211	18-3390	18-3315-2	18-3405
115	1969-70	18-3044	—	—	—	—	—	—	—
115	1973-76	18-3043	—	—	—	—	18-3384	—	—
115	1977-78	18-3043	—	18-3346	—	—	—	18-3393⑦	18-3391
115	1979-sup	18-3059	—	18-3346	—	18-3211	18-3390	18-3392②	18-3391
115 SL,DL	1995 & SUP	18-3059	—	18-3346	—	18-3211	18-3390	18-3315-2	18-3405
120 25" ④	1993-2000	18-3059	—	18-3346	—	18-3211	18-3390	18-3315-2	18-3405
125	1971-72	18-3044	—	—	—	—	—	—	—
125 ESX 25" ③	1993-94	18-3059	—	18-3346	—	18-3211	18-3390	18-3392	18-3391
125 ESX 25"	1994-95	18-3059	—	18-3346	—	18-3211	18-3390	18-3392	18-3391
125 ESX 25" ④	1993-94	18-3059	—	18-3346	—	18-3211	18-3390	—	—
130	1997 & SUP	18-3059	—	18-3346	—	18-3211	18-3390	18-3315-2	18-3405

① Excepto bombas cromadas

② Excepto modelos SL 1995 & Sup/FFI

③ "S" Sufijo

④ "F" Sufijo

⑤ Excepto 1993-94 25" & 30" V6 & V8

⑦ Para bombas de agua de un solo tubo

⑥ Caja de engranajes 90°

HP	Año	Impulsor	Impulsor platina	Platina y tapa	Tapa	Kit reparación	Kit bomba S/ aloj.	Kit bomba c/aloj.	Kit alojamiento
130 25"	1994-2000	18-3059	—	18-3346	—	18-3211	18-3390	18-3315-1	18-3405
135	1973-75	18-3043	18-3182	—	—	18-3210	18-3384	—	—
135	1976	18-3043	18-3182	—	—	—	—	—	—
135 25"	2001	18-3059	—	18-3346	—	18-3211	18-3390	18-3315-2	18-3405
140	1977-78	18-3043	—	18-3346	—	—	—	18-3393⑦	18-3391
140	1979-sup	18-3059	—	18-3346	—	18-3211	18-3390	18-3392	18-3391
140 25" ④	1993	18-3059	—	18-3346	—	18-3211	18-3390	18-3315-2	18-3405
140 25"	1994-2000	18-3059	—	18-3346	—	18-3211	18-3390	18-3315-2	18-3405
150	1976-78	18-3043	—	18-3346	—	18-3210	—	18-3393⑦	18-3391
150	1979-sup	18-3059	—	18-3346	—	18-3211	18-3390	18-3392	18-3391
150 20"	1993 & SUP	18-3059	—	18-3346	—	18-3211	18-3390	18-3392	18-3391
150 SL 20"	1994-98	18-3059	—	18-3346	—	18-3211	18-3390	18-3315-2	18-3405
150 EL 20"	1996-98	18-3059	—	18-3346	—	18-3211	18-3390	18-3315-2	18-3405
150 25"	1993 & SUP	18-3059	—	18-3346	—	18-3211	18-3390	18-3315-2	18-3405
150 DI	1997 & SUP	18-3059	—	18-3346	—	18-3211	18-3390	18-3315-2	18-3405
150	2000 & SUP	18-3059	—	18-3346	—	18-3211	18-3390	18-3315-2	18-3405
175	1976-78	18-3043	—	18-3346	—	18-3210	—	18-3393⑦	18-3391
175 SL 20"	1994-98	18-3059	—	18-3346	—	18-3211	18-3390	18-3315-2	18-3405
175 EL 20"	1996-98	18-3059	—	18-3346	—	18-3211	18-3390	18-3315-2	18-3405
175 25"	1993 & SUP	18-3059	—	18-3346	—	18-3211	18-3390	18-3315-2	18-3405
175 DI	1997 & SUP	18-3059	—	18-3346	—	18-3211	18-3390	18-3315-2	18-3405
175	2000 & SUP	18-3059	—	18-3346	—	18-3211	18-3390	18-3315-2	18-3405
200	1976-78	18-3043	—	18-3346	—	—	—	18-3393⑦	18-3391
200 Comm.	1990	18-3059	—	18-3346	—	18-3211	18-3390	18-3392	18-3391
200 25" & 30"	1993-97	18-3059	—	18-3346	—	18-3211	18-3390	18-3315-2	18-3405
225 20"	1993 & SUP	18-3059	—	18-3346	—	18-3211	18-3390	18-3392	18-3391
225 25" & 30"	1993-97	18-3059	—	18-3346	—	18-3211	18-3390	18-3315-2	18-3405
235	1978	18-3043	—	18-3346	—	—	—	18-3393⑦	18-3391
235	1979-sup	18-3059	—	18-3346	—	18-3211	18-3390	18-3392	18-3391
V4 Cross 20" & 25"	1993 & SUP	18-3059	—	18-3346	—	18-3211	18-3390	18-3392	18-3391
V4 Loop 20"	1993 & SUP	18-3059	—	18-3346	—	18-3211	18-3390	18-3392	18-3391
V4,V6,V8 ⑤	1982-94	18-3059	—	18-3346	—	18-3211	18-3390	18-3392	18-3391
V6,V8 20"	1993 & SUP	18-3059	—	18-3346	—	18-3211	18-3390	18-3392	18-3391
V6 & V8 25" & 30"	1993 & UP	18-3059	—	18-3346	—	18-3211	18-3390	18-3315-2	18-3405
Sea Drives	1979-Up	18-3059	—	18-3346	—	18-3211	18-3390	18-3392⑥	18-3391

- ① Excepto Bombas cromadas ③ "S" Sufijo ⑤ Excepto 1993-94 25" & 30" V6 & V8
 ② Excepto SL modelos 1995 & Sup/FFI ④ "F" Sufijo ⑦ para Bombas de agua con 1 tubo ⑧ Caja engranajes 90°

 <p>18-3563 VALVULA V-6 Crossflow Reemplaza: 32102r</p>	 <p>18-3564 VALVULA V-4 Crossflow Reemplaza: 318395</p>	 <p>18-1219 CASQUILLO V-6 Crossflow Reemplaza: 320880</p>	<p>PACK. DE 2</p>  <p>18-1221 TAPA VALVULA V-4 / V-6 Loop Charge Reemplaza: 330273</p>
 <p>18-3562 TAPA VALVULA V-6 Crossflow Reemplaza: 321222</p>	 <p>18-1243 MUELLE VALVULA V-4 / V-6 Crossflow Reemplaza: 317245</p>	 <p>18-1222 JUNTA TERMOSTATO V-4 / V-6 Loop Charge Reemplaza: 394408</p>	 <p>18-3567 VALVULA GOMA V-6 Crossflow Reemplaza: 321221</p>

① Precio por pack



**18-3565
RETENEDOR**
V-6 Crossflow
Reemplaza: 321220



**18-2391
CASQUILLO**
V-4 Crossflow
Reemplaza: 321692



**18-3500
TERMOSTATO**
Reemplaza: 394409, 434137
Para: 3 cil. (1992 & SUP),
90° Looper (1990-1992)
140°



**18-3544
TERMOSTATO**
Reemplaza: 435491
Para: E100 (2004-06), E110 (04-06), E115 (2002-06), E75 (2002-03), E90 (2002-03), E150 (1991-94), E175 (1991-94), J105 (2003), J115 (2002-06), J150 (1991-92, 1993-94, 2002-06), J175 (1991-92, 1994, 2002-06), J90 (2004-06)



**18-3545
TERMOSTATO 130°**
Reemplaza: 437090
Para: E115 (1997),
E135, E150, E175 (2000-06)



**18-3546
TERMOSTATO 130°**
Reemplaza: 5001036
Para: E200, E225, E250 (2000-05),
J200, J225, J250 (2000-01)



**18-3543
TERMOSTATO 143°**
Reemplaza: 393659, 434841,
378065, 508626, 5005440
Para: 40-250hp E-tech, 6-55hp, Cross V4 &
V6, 9.9 4-tiempos (1994-01), 15 4-tiempos
(1994-01)



**18-3643
TERMOSTATO**
Reemplaza: 433379
Para: 6-8 HP (1990), 9.9/15 HP (1990-
92), 40/48/50 HP (1990-94), 45/55
(1992-94)



**18-3557
TERMOSTATO 143°**
Reemplaza: 396987, 382385



**18-3561
TERMOSTATO**
Reemplaza: 436195
143°



**18-1506
TERMOSTATO 143°**
Reemplaza: 394411
Para: 10/15 (1993-95), 60/125/185 (1989-90),
65 (1987-89), 70/200/225 (1986-90),
120/140/300 (1985-90), 275 (1985-88)



**18-3560
TERMOSTATO**
Reemplaza: 384719
105°
Para mayoría 3 & 4 cil., 1985-90

① 18-3669D Display Package



**18-3669
KIT TERMOSTATO**
- CONTIENE -

Ref #	Descripción	O.E. #
18-3557	Termostato	396987
18-2548	Junta tapa termostato	332108
18-0929	Junta termostato	313416

① 18-3673D Display Package



**18-3673
KIT TERMOSTATO**
V-4 Crossflow
Use termostato 18-3543

① 18-3674D Display Package



**18-3674
KIT TERMOSTATO**
V-6 Crossflow
Use termostato 18-3543



**18-3566
CODO MANGUERA**
Reemplaza: 331894



**18-1507
RETÉN TERMOSTATO**
Reemplaza: 335981
Para: 60° V-4 & V-6



**18-1734
RETÉN TERMOSTATO**
Reemplaza: 334742
Para: OMC termostato aplicación 6, 8, 10, 15,
40, 48, 50 HP (1989-94)

APLICACIÓN EN LA PÁGINA 177

① Referencias acabadas en "D" envasadas - Referencia normal no envasada

Crossflow motor V-4

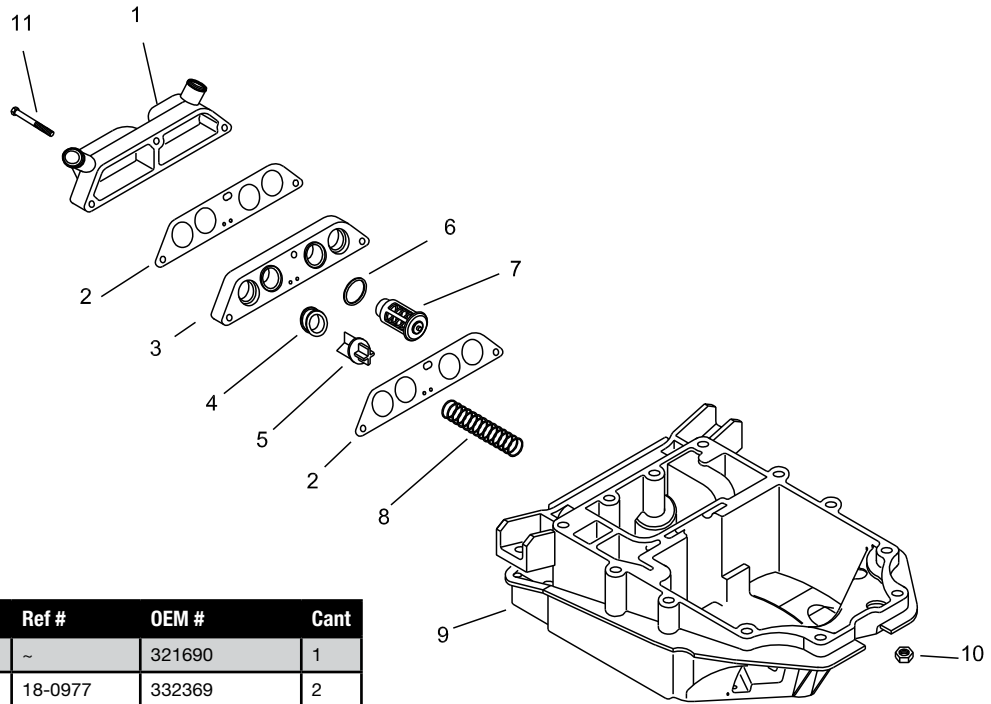

Fig. #	Descripción	Ref #	OEM #	Cant
1	Tapa	~	321690	1
2	Junta	18-0977	332369	2
3	Cuerpo válvula	~	321693	1
4	Casquillo	18-2391	321692	2
5	Válvula	18-3564	318395	2
6	Junta termostato	18-0675	321932	2
7	Termostato	18-3543	434841, 393659	2
8	Muelle	18-1243	317245	2
9	Adaptador	~	331039	1
10	Tuerca	~	306422	4
11	Tapa tornillo	~	305652	3

Crossflow motor V-6

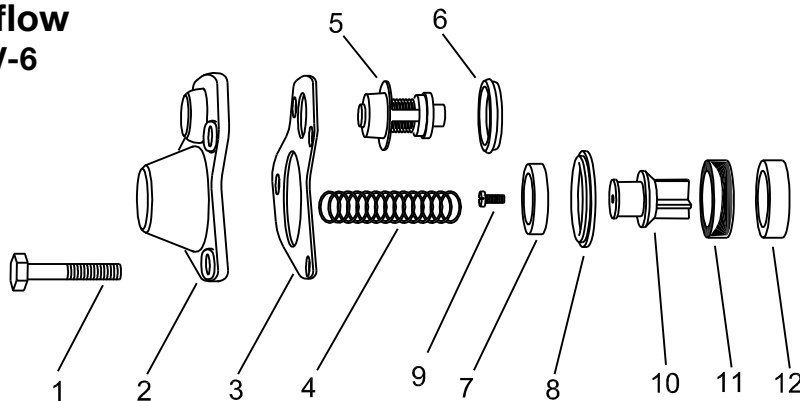

Fig. #	Descripción	Ref #	OEM #	Cant
1	Tornillos	—	306778	4
2	Tapa	—	321013	1
3	Junta	18-2546	321184	1
4	Muelle	18-1243	317245	1
5	Termostato	18-3543	393659	1
6	Junta termostato	18-0182	310058	1

Fig. #	Descripción	Ref #	OEM #	Cant
7	Retenedor	18-3565	321220	1
8	Retén	18-3567	321221	1
9	tornillo acero inox	18-3135	306643	1
10	Válvula	18-3563	321027	1
11	Casquillo	18-1219	320880	1
12	Tapa válvula	18-3562	321222	1

HP	Años	Kit termostato	Termostato	Válvula	Asiento válvula	Válvula diafragma	Válvula retenedor	Tapa válvula	Muelle válvula	Casquillo
5	1965-68, 1986	18-3672 ⑤	18-3543	—	—	—	—	—	—	—
5.5	1959-64	18-3672 ⑤	18-3543	—	—	—	—	—	—	—
6	1965-79, 1986	18-3672 ⑤	18-3543	—	—	—	—	—	—	—
7.5	1980-86	18-3672 ⑤	18-3543	—	—	—	—	—	—	—
8	1986	18-3672 ⑤	18-3543	—	—	—	—	—	—	—
9.5	1964-73	18-3672 ⑤	18-3543	—	—	—	—	—	—	—
9.9	1974-86	18-3672 ⑤	18-3543	—	—	—	—	—	—	—
10	1959-63	18-3672 ⑤	18-3543	—	—	—	—	—	—	—
15	1974-86	18-3672 ⑤	18-3543	—	—	—	—	—	—	—
18	1959-73	18-3672 ⑤	18-3543	—	—	—	—	—	—	—
20	1981-94	18-3672 ⑤	18-3543	—	—	—	—	—	—	—
25 ①	1969-94	18-3672 ⑤	18-3543	— ①	—	—	—	—	—	—
28	1989-94	18-3672 ⑤	18-3543	—	—	—	—	—	—	—
30	1986-94	18-3672 ⑤	18-3543	—	—	—	—	—	—	—
35	1959, 1976-94	18-3672 ⑤	18-3543	—	—	—	—	—	—	—
40	1960-69	18-3672 ⑤	18-3543	—	—	—	—	—	—	—
45	1989-92 ②	18-3672 ⑤	18-3543	—	—	—	—	—	—	—
50	1971-75, 1979, 1981-86	18-3672 ⑤	18-3543	—	—	—	—	—	—	—
55	1976-92 ③	18-3672 ⑤	18-3543	—	—	—	—	—	—	—
60	1969-70	18-3669 ⑤	18-3557	—	—	—	—	—	—	—
60	1980-86	18-3672 ⑤	18-3543	—	—	—	—	—	—	—
60, 60TTL	1993	—	18-3561	—	—	—	—	—	—	—
65	1971-73	18-3669	18-3557	—	—	—	—	—	—	—
65	1993	—	18-3561	—	—	—	—	—	—	—
65C	1984-86	18-3669	18-3557	—	—	—	—	—	—	—
65 Jet	1994-95	18-3673	18-3543	18-3564	—	—	—	—	18-1243	18-2391
70	1974-86	18-3669	18-3557	—	—	—	—	—	—	—
70,70TTL	1993	—	18-3561	—	—	—	—	—	—	—
75	1978-88	18-3669	18-3557	—	—	—	—	—	—	—
80 Jet	1994-95	18-3673	18-3543	18-3564	—	—	—	—	18-1243	18-2391
85	1978-80	18-3673	18-3543	18-3564	—	—	—	—	18-1243	18-2391
85	1993-95	18-3673	18-3543	18-3564	—	—	—	—	18-1243	18-2391
88	1987-95	18-3673	18-3543	18-3564	—	—	—	—	18-1243	18-2391
90 ④	1983-95	18-3673	18-3543	18-3564	—	—	—	—	18-1243	18-2391
90 Jet	1994	18-3673	18-3543	18-3564	—	—	—	—	18-1243	18-2391
100	1979-80	18-3673	18-3543	18-3564	—	—	—	—	18-1243	18-2391
100	1990-95	18-3673	18-3543	18-3564	—	—	—	—	18-1243	18-2391
100 Comm	1984-95	18-3673	18-3543	18-3564	—	—	—	—	—	—
110	1985-89	18-3673	18-3543	18-3564	—	—	—	—	18-1243	18-2391
112	1994-95	18-3673	18-3543	18-3564	—	—	—	—	18-1243	18-2391
115 ④	1978-95	18-3673	18-3543	18-3564	—	—	—	—	18-1243	18-2391
120	1988-91	—	—	—	—	18-1222	—	18-1221	—	—
140	1978-85	18-3673	18-3543	18-3564	—	—	—	—	18-1243	18-2391
140	1988-91	—	—	—	—	18-1222	—	18-1221	—	—
150	1978-91	18-3672 ⑤	18-3543	18-3563	18-1219	18-3567	18-3565	18-3562	18-1243	18-0182
155	1984-91	18-3672 ⑤	18-3543	18-3563	18-1219	18-3567	18-3565	18-3562	18-1243	18-0182
175	1977-91	18-3672 ⑤	18-3543	18-3563	18-1219	18-3567	18-3565	18-3562	18-1243	18-0182
185	1984-85	18-3672 ⑤	18-3543	18-3563	18-1219	18-3567	18-3565	18-3562	18-1243	18-0182
200	1977-83	18-3672 ⑤	18-3543	18-3563	18-1219	18-3567	18-3565	18-3562	18-1243	18-0182
200	1988-93	—	—	—	—	18-1222	18-3565	18-1221	—	—
225	1988-93	—	—	—	—	18-1222	18-3565	18-1221	—	—
235	1978-85	18-3672	18-3543	18-3563	18-1219	18-3567	18-3565	18-3562	18-1243	18-0182

① Todos los modelos 1989-91 excepto DR & DT
② Comercial

③ También comercial
④ Excepto modelos 60^o

⑤ Para kit termostato completo incluyendo juntas y muelles usar 18-3674



LOS AROS PISTÓN TAMBIÉN SE SUMINISTRAN POR SEPARADO

KIT PISTONES
(VER TABLA PARA USOS ESPECÍFICOS)

HP	Cil.	Medida	Pistón	OEM Ref No.	Aro pistón	OEM Ref No.	OEM Ref No.	Clips	OEM Ref No.
9.9/15	2	2.188 / std.	—	397487	18-3931	386279	N/D	—	325262
9.9/15	2	2.218 / .030	—	396574	18-3933	386280	N/D	—	325262
9.9/15	2	2.188 / std.	18-4061	387660	18-3931	386279	N/D	—	325262
9.9/15	2	2.218 / .030	18-4062	387661	18-3933	386280	N/D	—	325262
25-35	2	3.000 / std.	18-4107	392621	18-3910	396377	320954	18-4290 ①	317831
25-35	2	3.020 / .020	—	N/D	18-3911	396378	320954	18-4290 ①	317831
25-35	2	3.030 / .030	—	396576	18-3912	396379	320954	18-4290 ①	317831
35-60	2 & 3	3.187 / std.	—	391798	18-3913	391170, 434107	322188	18-4290 ①	317831
35-60	2 & 3	3.207 / .020	—	N/D	18-3914	N/D	322188	18-4290 ①	317831
35-60	2 & 3	3.217 / .030	—	396581	18-3915	391416, 434109	322188	18-4290 ①	317831
60-75	3	3.000 / std.	18-4124	387284	18-3910	396377	320954	18-4290 ①	317831
60-75	3	3.020 / .020	18-4114	387285	18-3911	396378	320954	18-4290 ①	317831
60-75	3	3.030 / .030	18-4104	396583	18-3912	396379	320954	18-4290 ①	317831
50-70	3	3.187 / std.	18-4063	394461	18-3913	391170, 434107	322188	18-4290 ①	317831
50-70	3	3.217 / .030	18-4064	398483	18-3915	391416, 434109	322188	18-4290 ①	317831

KIT PISTONES SIERRA V-4/V-6
(VER TABLA PARA USOS ESPECÍFICOS)

Modelo/HP	Cil.	Medida	Pistón	OEM Ref #	Aro pistón	OEM Ref #	Bulón	OEM Ref #	Clips	OEM Ref #
85-300	4 & 6	3.5	18-4120	393271, 393924	18-3904	394930	18-4280	327861	18-4290 ①	317831
85-300	4 & 6	3.52	18-4110	—	18-3906	396503, 385662	18-4280	327861	18-4290 ①	317831
85-300	4 & 6	3.53	18-4100	396585, 396588	18-3905	396504	18-4280	327861	18-4290 ①	317831
150-235	4 & 6	3.625	18-4123	392455	18-3907	390509	18-4280	327861	18-4290 ①	317831
150-235	4 & 6	3.645	18-4113	N/D	—	N/D	18-4280	327861	18-4290 ①	317831
150-235	4 & 6	3.655	—	396587	18-3908	390510	18-4280	327861	18-4290 ①	317831

Loopers

120-300	4 & 6	3.685 (babor)	18-4065	432072, 432969	18-3975	431870	N.S.S.	—	18-4292	326765
120-300	4 & 6	3.685 (estribor)	18-4066	432073, 432970	18-3975	431870	N.S.S.	—	18-4292	326765
120-300	4 & 6	3.715 (babor)	18-4067	432077, 433003	—	431844	N.S.S.	—	18-4292	326765
120-300	4 & 6	3.715 (estribor)	18-4068	432078, 433004	—	431844	N.S.S.	—	18-4292	326765
120-300	4 & 6	3.500 (babor)	—	393566	18-3904	394930	18-4280	327861	18-4290 ①	317831
120-300	4 & 6	3.500 (estribor)	—	391481	18-3904	394930	18-4280	327861	18-4290 ①	317831
120-300	4 & 6	3.520 (babor)	—	N/D	18-3906	396503, 385662	18-4280	327861	18-4290 ①	317831
120-300	4 & 6	3.520 (estribor)	18-4111	N/D	18-3906	396503, 385662	18-4280	327861	18-4290 ①	317831
120-300	4 & 6	3.530 (babor)	18-4102	393612	18-3905	396504	18-4280	327861	18-4290 ①	317831
120-300	4 & 6	3.530 (estribor)	18-4101	391653	18-3905	396504	18-4280	327861	18-4290 ①	317831
185, 200-225	6	3.5995 (babor)	estándard 18-4190	436860	18-3901	436254	—	—	—	—
185, 200-225	6	3.5995 (estribor)	estándard 18-4079	436859	18-3901	436254	—	—	—	—
185, 200-225	6	3.5995 (babor)	0.02 18-4195	439015	—	439538	—	—	—	—
185, 200-225	6	3.5995 (estribor)	0.02 18-4086	439516	—	439538	—	—	—	—

① Precio por pieza. Para pedir envasado añada 9 a la referencia.

PISTÓN EN LINEA & APLICACIÓN AROS

HP	Año	Cil	Medida Estand	Pistón estand.	.020 OS Pistón	.030 OS Pistón	Aros estand	Aros .020 OS	Aros .030 OS
5/6/8/7.5	1986-95	2	1.937	18-4069	—	—	18-3972	—	—
9.9/15	1974-80	2	2.188	18-4061	—	18-4062	18-3931	—	18-3933
9.9/15	1981-93	2	2.188	—	—	—	18-3931	—	18-3933
10	1988-90	2	2.188	—	—	—	18-3931	—	18-3933
14	1988-90	2	2.188	—	—	—	18-3931	—	18-3933
15 4-tiempos	1995-UP	2	2.188	—	—	—	18-3931	—	18-3933
18 Jet	1995-98	2	3	18-4107	—	—	18-3910	18-3911	18-3912
20	1981-99	2	3	18-4107	—	—	18-3910	18-3911	18-3912
25	1977-80	2	3	—	—	—	18-3910	18-3911	18-3912
25	1981-96	2	3	18-4107	—	—	18-3910	18-3911	18-3912
25	1983-93	2	3.187	—	—	—	18-3913	18-3914	18-3915
28	1986-96	2	3	18-4107	—	—	18-3910	18-3911	18-3912
28 Jet	1995-96	2	3.187	—	—	—	18-3913	18-3914	18-3915
30	1984-98	2	3	18-4107	—	—	18-3910	18-3911	18-3912
35	1976-80	2	3	—	—	—	18-3910	18-3911	18-3912
35	1981-92	2	3	18-4107	—	—	18-3910	18-3911	18-3912
35	1986-87	2	3.187	—	—	—	18-3913	18-3914	18-3915
35 Jet	1990-98	2	3.187	—	—	—	18-3913	18-3914	18-3915
40	1975-83	2	3.187	—	—	—	18-3913	18-3914	18-3915
40	1984-98	2	3.187	—	—	—	18-3913	18-3914	18-3915
40 Comm.	1981-97	2	3.187	—	—	—	18-3913	18-3914	18-3915
45 Comm.	1985-92	2	3.187	—	—	—	18-3913	18-3914	18-3915
45SS	1987-90	2	3.187	—	—	—	18-3913	18-3914	18-3915
48	1987-97	2	3.187	—	—	—	18-3913	18-3914	18-3915
50	1981-95	2	3.187	—	—	—	18-3913	18-3914	18-3915
50	1995-98	3	3.187	18-4063	—	18-4064	18-3913	18-3914	18-3915
55	1976-79	2	3.187	—	—	—	18-3913	18-3914	18-3915
55 Comm.	1980-95	2	3.187	—	—	—	18-3913	18-3914	18-3915
60	1980-85	2	3.187	—	—	—	18-3913	18-3914	18-3915
60 (49 CID Modelo)	1986-88	3	3	18-4124	18-4114	18-4104	18-3910	18-3911	18-3912
60	1986-98	3	3.187	18-4063	—	18-4064	18-3913	18-3914	18-3915
65, 65 Comm.	1972-73	3	3	—	—	—	18-3910	18-3911	18-3912
49 CID Modelo	1984-86	3	3	18-4124	18-4114	18-4104	18-3910	18-3911	18-3912
65	1987-95	3	3.187	18-4063	—	18-4064	18-3913	18-3914	18-3915
65 Jet	1991-95	4	3.5	18-4120	18-4110	18-4100	18-3904	18-3906	18-3905
70	1974-75	3	3	—	—	—	18-3910	18-3911	18-3912
70	1976-85	3	3	18-4124	18-4114	18-4104	18-3910	18-3911	18-3912
70	1986-94	3	3.187	18-4063	—	18-4064	18-3913	18-3914	18-3915
75	1975	3	3	—	—	—	18-3910	18-3911	18-3912
75	1976-88	3	3	18-4124	18-4114	18-4104	18-3910	18-3911	18-3912

PISTONES JOHNSON/EVINRUDE (para aplicaciones V-4, V-6 y V-8 Aplicaciones)

HP	Cil	Año	Medida. estand	ESTÁNDAR		.020" OS		.030" OS		Aros estand	Aros .020 OS	Aros .030 OS	Juego cojinetes
				babor	estribor	babor	estribor	babor	estribor				
65 Jet	4	1991-95	3.5	18-4120	18-4120	18-4110	18-4110	18-4100	18-4100	18-3904	18-3906	18-3905	18-1386
80 Jet	4	1991-96	3.5	18-4120	18-4120	18-4110	18-4110	18-4100	18-4100	18-3904	18-3906	18-3905	—
85	4	1979-80, 1991-95	3.5	18-4120	18-4120	18-4110	18-4110	18-4100	18-4100	18-3904	18-3906	18-3905	18-1386
88	4	1987-95	3.5	18-4120	18-4120	18-4110	18-4110	18-4100	18-4100	18-3904	18-3906	18-3905	18-1386
90	4	1981-98	3.5	18-4120	18-4120	18-4110	18-4110	18-4100	18-4100	18-3904	18-3906	18-3905	18-1386
100 ①	4	1979-97	3.5	18-4120	18-4120	18-4110	18-4110	18-4100	18-4100	18-3904	18-3906	18-3905	18-1386
110	4	1986-90	3.5	18-4120	18-4120	18-4110	18-4110	18-4100	18-4100	18-3904	18-3906	18-3905	18-1386
115	4	1974-77	3.5	18-4120	18-4120	18-4110	18-4110	18-4100	18-4100	18-3904	18-3906	18-3905	—
115	4	1978-98	3.5	18-4120	18-4120	18-4110	18-4110	18-4100	18-4100	18-3904	18-3906	18-3905	18-1386

① Excepto modelos 1991 60° V

PISTONES JOHNSON/EVINRUDE (para aplicaciones V-4, V-6 y V-8) (Cont.)

HP	Cil	Año	Medida. estand	ESTÁNDAR		.020" OS		.030" OS		Aros estand	Aros .020 OS	Aros .030 OS	Juego cojinetes
				babor	estribor	babor	estribor	babor	estribor				
120	4	1985-87	3.5	—	—	—	18-4111	18-4102	18-4101	18-3904	18-3906	18-3905	—
120	4	1988-94	3.685	18-4065	18-4066	—	—	18-4067	18-4068	18-3975	—	—	—
125 Comm.	4	1992-95	3.685	18-4065	18-4066	—	—	18-4067	18-4068	18-3975	—	—	—
130	4	1995-98	3.685	18-4065	18-4066	—	—	18-4067	18-4068	18-3975	—	—	—
135	4	1974-76	3.5	18-4120	18-4120	18-4110	18-4110	18-4100	18-4100	18-3904	18-3906	18-3905	—
140	4	1977	3.5	18-4120	18-4120	18-4110	18-4110	18-4100	18-4100	18-3904	18-3906	18-3905	—
140	4	1978-84	3.5	18-4120	18-4120	18-4110	18-4110	18-4100	18-4100	18-3904	18-3906	18-3905	18-1386
140	4	1985-87	3.5	—	—	—	18-4111	18-4102	18-4101	18-3904	18-3906	18-3905	—
140	4	1988-94	3.685	18-4065	18-4066	—	—	18-4067	18-4068	18-3975	—	—	—
1600CC	4	1988	3.5	18-4120	18-4120	18-4110	18-4110	18-4100	18-4100	18-3904	18-3906	18-3905	18-1386
150	6	1973-77	3.5	18-4120	18-4120	18-4110	18-4110	18-4100	18-4100	18-3904	18-3906	18-3905	—
150	6	1978-91	3.5	18-4120	18-4120	18-4110	18-4110	18-4100	18-4100	18-3904	18-3906	18-3905	—
155 Comm.	6	1984-92	3.5	18-4120	18-4120	18-4110	18-4110	18-4100	18-4100	18-3904	18-3906	18-3905	—
175	6	1977-83	3.5	18-4120	18-4120	18-4110	18-4110	18-4100	18-4100	18-3904	18-3906	18-3905	—
175	6	1986-91	3.625	18-4123	18-4123	18-4113	18-4113	—	—	18-3907	—	18-3908	—
185	6	1984-85	3.5	18-4120	18-4120	18-4110	18-4110	18-4100	18-4100	18-3904	18-3906	18-3905	—
185	6	1990-93	—	—	—	—	—	—	—	—	—	—	18-1389
185 Looper	6	1993-94	3.5995	18-4190	18-4079	18-4195	18-4086	—	—	—	—	—	—
200	6	1976-83	3.5	18-4120	18-4120	18-4110	18-4110	18-4100	18-4100	18-3904	18-3906	18-3905	18-1389
200	6	1985-87	3.5	—	—	—	18-4111	18-4102	18-4101	18-3904	18-3906	18-3905	—
200	6	1988-93	3.685	18-4065	18-4066	—	—	18-4067	18-4068	18-3975	—	—	18-1389
200-225 Looper	6	1993-01	3.5995	18-4190	18-4079	18-4195	18-4086	—	—	—	—	—	—
225	6	1985-87	3.5	—	—	—	18-4111	18-4102	18-4101	18-3904	18-3906	18-3905	18-1389
225	6	1988-93	3.685	18-4065	18-4066	—	—	18-4067	18-4068	18-3975	—	—	18-1389
235	6	1980-85	3.625	18-4123	18-4123	18-4113	18-4113	—	—	18-3907	—	18-3908	—
250/300	6	1990-93	3.685	18-4065	18-4066	—	—	18-4067	18-4068	18-3975	—	—	—
2500CC	6	1988	3.5	18-4120	18-4120	18-4110	18-4110	18-4100	18-4100	18-3904	18-3906	18-3905	—
250	6	1988-92	3.685	18-4065	18-4066	—	—	18-4067	18-4068	18-3975	—	—	—
275	8	1988-92	3.685	18-4065	18-4066	—	—	18-4067	18-4068	18-3975	—	—	—
275	8	1985-87	3.5	—	—	—	18-4111	18-4102	18-4101	18-3904	18-3906	18-3905	—
300	8	1988-92	3.685	18-4065	18-4066	—	—	18-4067	18-4068	18-3975	—	—	—
300/3.6L	8	1985-87	3.5	—	—	—	18-4111	18-4102	18-4101	18-3904	18-3906	18-3905	—



Serie Eagle 60°

HP	Cil.	Medida	Piston	OE No.	Aro Pistón	OE No.
90-175	4 & 6	3.600 (babor)	—	436242	18-4088	436353
90-175	4 & 6	3.600(estribor)	—	436243	18-4088	436353
90-175	4 & 6	3.620 (babor)	—	N/D	—	N/D
90-175	4 & 6	3.620 (estribor)	—	N/D	—	N/D
90-175	4 & 6	3.630 (babor)	—	439519	—	436354

Pistón serie eagle OMC V-4/V-6 60°

H.P.	Año	CIL.	MEDIDA. ESTANDAR	STANDARD		.020"O.S.		.030"O.S.		STD.
				(BABOR)	(ESTRIBOR)	(BABOR)	(ESTRIBOR)	(BABOR)	(ESTRIBOR)	AROS
90-175	1991-2000	4 & 6	3.600		—		—		—	18-4088

PISTONES OMC SEA DRIVE

H.P.	AÑO	CIL.	STD. BORE	ESTANDARD		.020"O.S.		.030"O.S.		STD. AROS	.020" O.S. AROS	.030" O.S. AROS
				(BABOR)	(ESTRIBOR)	(BABOR)	(ESTRIBOR)	(BABOR)	(ESTRIBOR)			
1.6L	1983-89	4	3.500	18-4120	18-4120	18-4110	18-4110	18-4100	18-4100	18-3904	18-3906	18-3905
1.8L	1987	4	3.500	—	—	—	18-4111	18-4102	18-4101	18-3904	18-3906	18-3905
2.5L	1982, 1984-85	6	3.500	18-4120	18-4120	18-4110	18-4110	18-4100	18-4100	18-3904	18-3906	18-3905
2.6L	1982-86	6	3.625	18-4123	18-4123	18-4113	18-4113	—	—	18-3907	—	18-3908
2.7L	1987	6	3.500	—	—	—	18-4111	18-4102	18-4101	18-3904	18-3906	18-3905
3.6L	1987	8	3.500	—	—	—	18-4111	18-4102	18-4101	18-3904	—	18-3905

LOS FABRICANTES RECOMIENDAN EL CAMBIO DE LAS BIELAS



TORNILLOS BIELA

Ref #	OE#	Aplicación
18-4075	308186	Para V-4 & V-6 Motores Crossflow
18-4075-9 ^{①②}	308186	Para V-4 & V-6 Para motores Crossflow
18-4076	330081	Para motores V-4 Looper



18-1752

BIELA

Reemplaza: 394462
Para: 40HP (1999-01), 50HP (1995-98), 60HP (1989-01), 70HP (1986-01)



18-1753

BIELA

Reemplaza: 395861
Para: 30HP (1999-01), 40 HP (1985-02), 45HP (1986-87, 1990-97), 48HP (1987-96), 50HP (1985-02), 55HP (1985-93, 1999-01), 60 HP (1985)



18-4148-1

BIELA

Reemplaza: 394488, 5004705
Para motores V-4 Looper y algunas aplicaciones V-6



18-4712

CAMISA PISTÓN

Reemplaza manguito recto con puertos cortados en ID - 3.1875 • OD - 3.453 • Pared - 0.125 • Longitud - 5.556



18-1352

COJINETE CENTRAL

Reemplaza: 378252



18-1353

COJINETE CENTRAL

Reemplaza: 387041



18-4197

ARBOL DE LEVAS

Reemplaza: 334665
Para: 60 HP (1989-92), 65 COMM HP (1989-92), 70 HP (1989-95)



18-1360

COJINETE BIELA

Reemplaza: 396041

APICACIONES EMPIEZAN EN LA SIGUIENTE PÁGINA

① PRECIO POR PACK ② Pack de 12

18-1361
COJINETE BIELA
Reemplaza: 387787



18-1296
COJINETE AGUJAS
Reemplaza: 386014
0.750 O.D. x 0.570 I.D. x 0.620 H
Para: 9.9-15 HP



18-1374
COJINETE DE AGUJAS
Reemplaza: 395627



18-1376
COJINETE DE AGUJAS
Reemplaza: 434844



18-1377
COJINETE CENTRAL PRINCIPAL
Reemplaza: 320499



18-1378
COJINETE BIELA
Reemplaza: 388344



18-4040
AGUJAS
(18 agujas)
Reemplaza: 387142, 387139
(extremo de cigüeñal)
(Debe reutilizar la jaula)



JUEGO COJINETES

18-1386
Contiene

Ref No.	Tipo cojinete	OE No.	Can
18-1353	Principal	387041	1
18-1377	Principal	320499	1
18-1374	Pasador	395627	4
18-1395	Inf	385503	1
18-1361	Extr. cig varilla	387787	4

18-1389
Contiene

Ref No.	Tipo cojinete	OE No.	Cant
18-1353	Principal	387041	2
18-1377	Principal	320499	2
18-1376	Pasador	434844	6
18-1396	Inf	390641	1
18-1360	Varilla	396041	4

COJINETES

Ref #	Reemplaza:	Descripción
18-1391	330854	Cojinete cigüeñal inferior
18-1395	385503	Cojinete cigüeñal inferior
18-1396	390641	Cojinete cigüeñal inferior



H.P.	Año	Camisa	Bielas	Tornillo Biela	Cojinete agujas.	Cojinete biela completo	Cojinete biela solo	Cojinete central principal	Cojinete cigüeñal	Cojinete sup. Cigüeñal	Cojinete inf. Cigüeñal	Juego de Cojinetes
2 CILINDROS												
9.9	1974-83	-	-	-	-	-	-	-	-	-	-	-
9.9	1974-83	-	-	-	-	-	-	-	-	-	-	-
9.9	1974-80	-	-	-	-	-	-	-	-	-	-	-
9.9	1981-83	-	-	-	-	-	-	-	-	-	-	-
9.9	1986-92	-	-	-	-	-	-	-	-	-	-	-
9.9	1984-97	-	-	-	-	-	-	-	-	-	-	-
9.9	1998	-	-	-	-	-	-	-	-	-	-	-
14 Comm	1988-89	-	-	-	-	-	-	-	-	-	-	-
15	1974-83	-	-	-	-	-	-	-	-	-	-	-
15	1984-97	-	-	-	-	-	-	-	-	-	-	-
15 Comm	1994	-	-	-	18-1296	-	-	-	-	-	-	-
18	1960-68	-	-	-	-	-	18-4040	-	-	-	-	-
18	1970-73	-	-	-	-	-	18-4040	-	-	-	-	-
18 Jet	1996-97	-	-	-	18-1374	18-1378	-	-	-	-	18-1391	-
20	1981-84	-	-	-	18-1374	18-1378	18-4040	-	-	-	18-1391	-
20	1985-97	-	-	-	18-1374	18-1378	-	-	-	-	18-1391	-

APLICACIONES CONTINÚAN EN LA PÁGINA SIGUIENTE

H.P.	Año	Camisa	Biela	Tornillo Biela	Cojinete agujas.	Cojinete biela completo	Cojinete biela solo	Cojinete central principal	Cojinete cigüeñal	Cojinete sup. Cigüeñal	Cojinete inf. Cigüeñal	Juego de Cojinetes
25	1970-76	-	-	-	-	-	18-4040	-	-	-	-	-
25	1977	-	-	-	-	18-1378	18-4040	-	-	-	18-1391	-
25	1978-80	-	-	18-4075	-	18-1378	18-4040	-	-	-	18-1391	-
25	1981-84	-	-	-	18-1374	18-1378	18-4040	-	-	-	18-1391	-
25 ①	1985-97	-	-	-	-	-	-	-	-	-	18-1391	-
25	1985-97	-	-	18-4075	18-1374	18-1378	-	-	-	-	-	-
25 Comm	1982-84	-	-	-	18-1374	18-1378	18-4040	-	-	-	18-1391	-
25 Comm	1985-97	-	-	-	18-1374	18-1378	-	-	-	-	18-1391	-
28	1987-97	-	-	-	18-1374	18-1378	-	-	-	-	18-1391	-
30	1981-93	-	-	18-4075	18-1374	18-1378	18-4040	-	-	-	-	-
30	1984-1992	-	-	18-4075	-	18-1378	18-4040	-	-	-	-	-
30	1985-97	-	-	-	18-1374	18-1378	18-4040	-	-	-	18-1391	-
30	1984	-	-	-	-	18-1378	18-4040	-	-	-	18-1391	-
33	1965-69	-	-	-	-	18-1378	18-4040	-	-	-	-	-
33	1970	-	-	-	-	18-1378	18-4040	-	-	-	-	-
35	1976-80	-	-	-	-	18-1378	18-4040	-	-	-	18-1391	-
35	1981-84	-	-	18-4075	18-1374	-	18-4040	-	-	-	18-1391	-
35	1985-97	-	-	-	18-1374	18-1378	-	-	-	-	18-1391	-
35	1976-1993	-	-	18-4075	18-1374	18-1378	-	-	-	-	-	-
35	1977	-	-	18-4075	-	-	-	-	-	-	-	-
35	1978-1980	-	-	18-4075	-	18-1378	18-4040	-	-	-	18-1391	-
35	1981-1993	-	-	18-4075	18-1374	18-1378	-	-	-	-	18-1391	-
40	1984-92	18-4712	-	18-4075	18-1374	18-1378	-	18-1352	-	-	18-1391	-
40	1961-70	-	-	-	-	-	18-4040	-	-	-	-	-
40	1971-73	-	-	-	-	18-1378	18-4040	-	-	-	-	-
40	1974-76	-	-	-	-	18-1378	18-4040	18-1352	-	-	18-1154	-
40	1984-86	-	-	-	18-1374	18-1378	-	18-1352	-	18-1372	18-1154	-
40	1987-97	-	-	-	18-1374	18-1378	-	18-1352	-	-	18-1154	18-1389
40	1983	-	-	18-4075	-	-	-	18-1352	-	-	18-1154	-
40 Comm	1982-83	-	-	-	-	18-1378	-	18-1352	-	-	-	-
40 Comm	1984-85	-	-	-	-	18-1378	-	18-1352	-	18-1372	-	-
40 Comm	1989-90	-	-	-	-	18-1378	-	18-1352	-	-	-	-
40 Comm	1994	-	-	-	18-1374	18-1378	-	18-1352	-	-	-	-
40 Comm	1995-97	-	-	-	18-1374	-	-	18-1352	-	-	-	-
45 Comm	1985-86	-	-	-	18-1374	18-1378	-	18-1352	-	18-1372	-	-
45 Comm	1987-94	-	-	-	18-1374	18-1378	-	18-1352	-	18-1372	-	-
45 Comm	1995-97	-	-	-	18-1374	-	-	18-1352	-	-	-	-
45 Comm	1987	-	-	-	18-1374	18-1378	-	18-1352	-	-	18-1154	-
45ss	1987-90	-	-	-	18-1374	18-1378	-	18-1352	-	18-1372	-	-
48	1987	18-4712	-	-	18-1374	18-1378	-	18-1352	-	18-1372	-	-
48	1987-92	18-4712	-	18-4075	18-1374	18-1378	-	18-1352	-	-	-	-
48	1988-96	-	-	-	18-1374	18-1378	-	18-1352	-	-	-	-
50	1979-83	18-4712	-	18-4075	18-1374	18-1378	18-4040	18-1352	-	18-1372	-	-
50	1979-86	-	-	-	18-1374	18-1378	-	18-1352	-	18-1372	-	-
50	1981-93	18-4712	-	18-4075	18-1374	18-1378	-	18-1352	-	-	-	-
50②	1987-97	-	-	-	18-1374	18-1378	-	18-1352	-	-	-	-
50③	1995-97	-	-	-	18-1374	18-1378	-	18-1352	-	-	-	-
55	1968-69	-	-	-	-	18-1378	18-4040	18-1352	-	-	-	-
55	1976-81	-	-	-	18-1374	18-1378	18-4040	18-1352	-	18-1372	-	-
55 Comm	1982	-	-	-	18-1374	18-1378	18-4040	18-1352	-	18-1372	-	-
55 Comm	1983-86	-	-	-	18-1374	18-1378	-	18-1352	-	18-1372	-	-
55 Comm	1987-94	-	-	-	18-1374	18-1378	-	18-1352	-	-	-	-
55 Comm	1995-97	-	-	-	18-1374	18-1378	-	18-1352	-	-	-	-
55	1978-93	18-4712	-	18-4075	-	-	-	-	-	-	-	-
60	1980-85	18-4712	-	18-4075	18-1374	18-1378	-	18-1352	-	18-1372	-	-
60	1964-67,70-71	-	-	-	-	18-1378	18-4040	18-1352	-	-	-	-
60	86-90	-	-	-	18-1374	18-1378	-	18-1352	-	18-1372	-	-
60	1991-93	-	-	-	18-1374	18-1378	-	18-1352	-	-	-	-
60	1994-97	-	-	-	18-1374	-	-	18-1352	-	-	-	-
SST-60	1989-90	-	-	-	18-1374	18-1378	-	18-1352	-	18-1372	-	-
3 CILINDROS												
60	1985	-	-	18-4075	18-1374	18-1378	18-4040	18-1352	-	18-1372	-	-
60	1986-90	-	-	-	18-1374	18-1378	18-4040	18-1352	-	18-1372	-	-
60	1986-88	-	-	18-4075	18-1374	18-1378	18-4040	18-1352	-	18-1372	-	-
60	1989-92	-	-	18-4075	18-1374	18-1378	18-4040	18-1352	-	-	-	-
65	1968	-	-	-	-	18-1378	18-4040	18-1352	-	-	-	-
65	1972-73	-	-	-	-	18-1378	18-4040	18-1352	-	18-1372	-	-
65 Comm	1984	-	-	-	18-1374	18-1378	18-4040	18-1352	-	18-1372	-	-
65 Comm	1985-90	-	-	-	18-1374	18-1378	18-4040	18-1352	-	18-1372	-	-
65 Comm	1991-93	-	-	-	18-1374	18-1378	18-4040	18-1352	-	-	-	-
65 Comm.	1994-97	-	-	-	18-1374	18-1378	18-4040	18-1352	-	-	-	-
65	1984-86	-	-	18-4075	18-1374	18-1378	18-4040	18-1352	-	18-1372	18-1154	-
70	1976-85	-	-	18-4075	18-1374	18-1378	18-4040	18-1352	-	18-1372	18-1154	-
70	1974-75	-	-	-	-	18-1378	18-4040	18-1352	-	18-1372	-	-
70	1976-90	-	-	-	18-1374	18-1378	18-4040	18-1352	-	18-1372	18-1154	-

① Excepto Modelos "D"

② Modelos dos cilindros

③ Modelos tres cilindros

④ Modelos 90 grados

⑤ Modelos 60 grados

⑥ Modelos motores no incluyen cojinetes superiores kits V-4, V-6 & V-8

APLICACIONES CONTINÚAN EN LA SIGUIENTE PÁGINAS

H.P.	Año	Camisa	Biela	Tornillo Biela	Cojinete agujas.	Cojinete biela completo	Cojinete biela solo	Cojinete central principal	Cojinete cigüeñal	Cojinete sup. Cigüeñal	Cojinete inf. Cigüeñal	Juego de Cojinetes
70	1976-84	-	-	18-4075	18-1374	18-1378	18-4040	18-1352	-	18-1372	18-1154	-
70	1985-90	-	-	-	18-1374	18-1378	18-4040	18-1352	-	18-1372	18-1154	-
70	1991-93	-	-	-	18-1374	18-1378	18-4040	18-1352	-	-	-	-
70	1994-97	-	-	-	18-1374	-	-	18-1352	-	-	-	-
75	1960-65	-	-	-	-	18-1378	18-4040	18-1352	-	-	-	-
75	1975	-	-	-	-	18-1378	18-4040	18-1352	-	18-1372	18-1154	-
75	1976-84	-	-	18-4075	18-1374	18-1378	18-4040	18-1352	-	18-1372	18-1154	-
75	1982-88	-	-	18-4075	18-1374	18-1378	18-4040	18-1352	-	18-1372	18-1154	-
75	1985-88	-	-	-	18-1374	18-1378	18-4040	18-1352	-	18-1372	18-1154	-
75 ⑥	1976-88	-	-	18-4075	18-1374	18-1378	18-4040	18-1352	-	18-1372	18-1154	-
V-4 CROSSFLOW												
65JET	1992-95	-	-	18-4075	18-1374	18-1361	18-4040	18-1353	18-1377	-	18-1395	18-1386
80	1966-67	-	-	-	-	18-1378	18-4040	18-1352	-	-	-	-
80JET	1993-97	-	-	18-4075	18-1374	18-1361	18-4040	18-1353	18-1377	-	18-1395	18-1386
80JET	1992-97	-	-	-	18-1374	181361	18-4040	18-1353	18-1377	-	18-1395	18-1386
85	1968-72	-	-	-	-	18-1378	18-4040	18-1352	-	-	18-1154	-
85	1973	-	-	-	18-1374	18-1378	18-4040	18-1352	-	-	18-1395	-
85	1974-78	-	-	-	18-1374	18-1361	18-4040	18-1352	-	-	18-1395	-
85 ⑥	1979-80	-	-	18-4075	18-1374	18-1361	18-4040	18-1353	18-1377	-	18-1395	18-1386
85 ⑥	1991-95	-	-	-	18-1374	18-1361	18-4040	18-1353	18-1377	-	18-1395	18-1386
85	1979-80,92	-	-	18-4075	18-1374	18-1361	18-4040	18-1353	18-1377	-	18-1395	18-1386
85TTL	1992-95	-	-	18-4075	18-1374	18-1361	18-4040	18-1353	18-1377	-	18-1395	18-1386
88	1987-91	-	-	18-4075	18-1374	18-1361	18-4040	18-1353	18-1377	-	18-1395	18-1386
88 ⑥	1987-96	-	-	18-4075	18-1374	18-1361	18-4040	18-1353	18-1377	-	18-1395	18-1386
88	1987-92	-	-	18-4075	18-1374	18-1361	18-4040	18-1353	18-1377	-	18-1395	18-1386
88	1993	-	-	18-4075	18-1374	18-1361	18-4040	18-1353	18-1377	-	18-1395	18-1386
88	1992-96	-	-	18-4075	18-1374	18-1361	18-4040	18-1353	18-1377	-	18-1395	18-1386
90	1981-86	-	-	18-4075	18-1374	18-1361	18-4040	18-1353	18-1377	-	18-1395	18-1386
90	1986-91	-	-	18-4075	18-1374	18-1361	18-4040	18-1353	18-1377	-	18-1395	18-1386
90	1992-94	-	-	18-4075	18-1374	18-1361	18-4040	18-1353	18-1377	-	18-1395	18-1386
90 ⑥ ④	1981-97	-	-	18-4075	18-1374	18-1361	18-4040	18-1353	18-1377	-	18-1395	18-1386
90 ④	1981-97	-	-	18-4075	18-1374	18-1361	18-4040	18-1353	18-1377	-	18-1395	18-1386
90 ⑤	1995-97	-	-	18-4075	18-1374	18-1361	18-4040	18-1353	18-1377	-	18-1395	18-1386
90JET ⑥	1994-95	-	-	18-4075	18-1374	18-1361	18-4040	18-1353	18-1377	-	18-1395	18-1386
90	1981-92	-	-	18-4075	18-1374	18-1361	18-4040	18-1353	18-1377	-	18-1395	18-1386
90	1993	-	-	18-4075	18-1374	18-1361	18-4040	18-1353	18-1377	-	18-1395	18-1386
100	1966-68	-	-	-	-	18-1378	18-4040	18-1352	-	-	18-1154	-
100	1971-72	-	-	-	-	18-1378	18-4040	18-1352	-	-	18-1154	-
100 ⑥	1979-80	-	-	18-4075	18-1374	18-1361	18-4040	18-1353	18-1377	-	18-1395	18-1386
100	1984-85	-	-	18-4075	18-1374	18-1361	18-4040	18-1353	18-1377	-	18-1395	18-1386
100	1986-91	-	-	18-4075	18-1374	18-1361	18-4040	18-1353	18-1377	-	18-1395	18-1386
100 ⑥	1990-94	-	-	18-4075	18-1374	18-1361	18-4040	18-1353	18-1377	-	18-1395	18-1386
100 Comm ⑥	1984-97	-	-	18-4075	18-1374	18-1361	18-4040	18-1353	18-1377	-	18-1395	18-1386
100	1979-81,92	-	-	18-4075	18-1374	18-1361	18-4040	18-1353	18-1377	-	18-1395	18-1386
100	1992-97	-	-	18-4075	18-1374	18-1361	18-4040	18-1353	18-1377	-	18-1395	18-1386
100	1993	-	-	18-4075	18-1374	18-1361	18-4040	18-1353	18-1377	-	18-1395	18-1386
100 Comm	1984-87,89-92	-	-	18-4075	18-1374	18-1361	18-4040	18-1353	18-1377	-	18-1395	18-1386
100 Comm.	1993	-	-	18-4075	18-1374	18-1361	18-4040	18-1353	18-1377	-	18-1395	18-1386
110 ⑥	1986-89	-	-	18-4075	18-1374	18-1361	18-4040	18-1353	18-1377	-	18-1395	18-1386
112 ⑥	1994-96	-	-	-	18-1374	18-1361	18-4040	18-1353	18-1377	-	18-1395	18-1386
115	1969-70	-	-	-	-	18-1378	18-4040	18-1352	-	-	18-1154	-
115	1973	-	-	18-4075	18-1374	18-1378	18-4040	18-1352	-	-	18-1395	-
115	1974-78	-	-	18-4075	18-1374	18-1361	18-4040	18-1352	-	-	18-1395	-
115 ⑥ ④	1990-97	-	-	-	18-1374	18-1361	18-4040	18-1353	18-1377	-	18-1395	18-1386
115 ⑥	1979-85	-	-	18-4075	18-1374	18-1361	18-4040	18-1353	18-1377	-	18-1395	18-1386
115	1991-92	-	-	18-4075	18-1374	18-1361	18-4040	18-1353	18-1377	-	18-1395	18-1386
115	1990-91	-	-	18-4075	18-1374	18-1361	18-4040	18-1353	18-1377	-	18-1395	18-1386
115	1993	-	-	18-4075	18-1374	18-1361	18-4040	18-1353	18-1377	-	18-1395	18-1386
115	1992-94	-	-	18-4075	18-1374	18-1361	18-4040	18-1353	18-1377	-	18-1395	18-1386
115 ④	1990-97	-	-	-	18-1374	18-1361	18-4040	18-1353	18-1377	-	-	-
115 ⑤	1995-97	-	-	-	-	18-1361	18-4040	18-1353	18-1377	-	-	-
115JET ⑥	1994-97	-	-	-	18-1374	18-1361	18-4040	18-1353	18-1377	-	18-1395	18-1386
115C	1984	-	-	18-4075	18-1374	18-1361	18-4040	18-1353	18-1377	-	18-1395	18-1386
120 ⑥	1985-94	-	-	-	18-1376	18-1360	-	18-1353	18-1377	-	18-1396	-
125	1971-72	-	-	-	-	18-1378	18-4040	18-1352	-	-	-	-
125 Comm ⑥	1989-95	-	-	-	18-1376	18-1360	-	18-1353	18-1377	-	18-1396	-
125Esx ⑥	1991-94	-	-	-	18-1376	18-1360	-	18-1353	18-1377	-	18-1396	-
130 ⑥	1994-97	-	-	-	18-1376	18-1360	-	18-1353	18-1377	-	18-1396	-
135	1973	-	-	-	18-1374	18-1378	18-4040	18-1352	-	-	18-1395	-
135	1974-76	-	-	18-4075	18-1374	18-1361	18-4040	18-1352	-	-	18-1395	-
140	1977-78	-	-	18-4075	18-1374	18-1361	18-4040	18-1352	-	-	18-1395	-
140	1979	-	-	18-4075	-	-	-	-	-	-	-	-
140 ⑥	1979-84	-	-	-	18-1374	18-1361	18-4040	18-1353	18-1377	-	18-1395	18-1386
140 ⑥	1985-94	-	-	-	18-1376	18-1360	-	18-1353	18-1377	-	18-1396	-
140	1977-84	-	-	18-4075	18-1374	18-1361	18-4040	18-1353	18-1377	-	18-1395	18-1386

① Excepto modelos "D"

② Modelos 2 cilindros

③ Modelos 3 cilindros

④ Modelos 90 grados





⑤ Modelos 60 grados

⑥ Modelos motores V-4, V-6 & V-8 no incluyen cojinetes superiores en kit

APLICACIONES CONTINÚAN EN LA SIGUIENTE PÁGINA

H.P.	Año	Camisa	Biela	Tornillo Biela	Cojinete agujas.	Cojinete biela completo	Cojinete biela solo	Cojinete central principal	Cojinete cigüeñal	Cojinete sup. Cigüeñal	Cojinete inf. Cigüeñal	Juego de Cojinetes
1600CC	1988	-	-	18-4075	-	-	-	-	-	-	-	-
1.6L	-	-	-	18-4075	-	-	-	-	-	-	-	-
V-6 CROSSFLOW												
150 ⑥	1978-91	-	-	-	18-1374	18-1361	18-4040	18-1353	18-1377	-	18-1395	-
150 ⑤	1991-97	-	-	-	-	18-1361	18-4040	18-1353	-	-	-	-
150 Comm ⑤	1993-95	-	-	-	-	18-1361	18-4040	18-1353	-	-	-	-
150	1978-85	-	-	18-4075	18-1374	18-1361	18-4040	18-1353	18-1377	-	18-1395	-
150	1978-88	-	-	18-4075	18-1374	18-1361	18-4040	18-1353	18-1377	-	18-1395	-
150	1986-91	-	-	18-4075	18-1374	18-1361	18-4040	18-1353	18-1377	-	-	-
150	1989-91	-	-	18-4075	18-1374	18-1361	18-4040	18-1353	18-1377	-	-	-
155 Comm	1984-85	-	-	18-4075	18-1374	18-1361	18-4040	18-1353	18-1377	-	18-1395	-
155 Comm ⑥	1984-92	-	-	-	18-1374	18-1361	18-4040	18-1353	18-1377	-	18-1395	-
155 Comm	1986-91	-	-	18-4075	-	-	-	-	-	-	-	-
175 ⑥	1977-91	-	-	-	18-1374	18-1361	18-4040	18-1353	18-1377	-	18-1395	-
175 ⑤	1991-97	-	-	-	-	18-1361	18-4040	18-1353	-	-	-	-
175	1977-83	-	-	18-4075	18-1374	18-1361	18-4040	18-1353	18-1377	-	-	-
175	1986-90	-	-	18-4075	18-1374	18-1361	18-4040	18-1353	18-1377	-	-	-
175	1977-83,85	-	-	18-4075	18-1374	18-1361	18-4040	18-1353	18-1377	-	-	-
185 ⑥	1984-85	-	-	18-4075	18-1374	18-1361	18-4040	18-1353	18-1377	-	18-1395	18-1389
185	1990	-	18-4148-1	18-4076	-	-	-	-	-	-	-	-
185 ⑥	1990-94	-	-	-	18-1376	18-1360	-	18-1353	18-1377	-	18-1396	18-1389
185	1990-93	-	18-4148-1	18-4076	-	-	-	-	-	-	-	-
185	1992-94	-	18-4148-1	18-4076	-	-	-	-	-	-	-	-
200 ⑥	1976-83	-	-	18-4075	18-1374	18-1361	18-4040	18-1353	18-1377	-	18-1395	18-1389
200	1986-97	-	-	-	18-1376	18-1360	-	18-1353	18-1377	-	18-1396	-
200 Comm	1990	-	18-4148-1	18-4076	-	-	-	-	-	-	18-1396	-
200 Comm	1990-94	-	-	-	18-1376	18-1360	-	18-1353	18-1377	-	-	-
200	1976-83	-	-	18-4075	18-1374	18-1361	18-4040	18-1353	18-1377	-	18-1395	-
200C	1990	-	-	18-4076	18-1376	18-1360	-	18-1353	18-1377	-	18-1396	-
200	1986-91	-	-	18-4076	-	-	-	-	-	-	-	-
200	1986-93	-	-	18-4076	-	-	-	-	-	-	-	-
225 ⑥	1986-97	-	-	-	18-1376	18-1360	-	18-1353	18-1377	-	18-1396	18-1389
235 ⑥	1978-85	-	-	18-4075	18-1374	18-1361	18-4040	18-1353	18-1377	-	18-1395	-
235	1978-79	-	-	18-4075	18-1374	18-1361	18-4040	18-1353	18-1377	-	-	-
235	1980-85	18-4718	-	18-4075	18-1374	18-1361	18-4040	18-1353	18-1377	-	-	-
250	1991-95	-	-	-	18-1376	18-1360	-	18-1353	18-1377	-	18-1396	-
250	1997	-	-	-	18-1376	18-1360	-	18-1353	18-1377	-	18-1396	-
275	1985-88	-	-	-	18-1376	18-1360	-	18-1353	18-1377	-	18-1396	-
3.6L	1985-87	-	-	-	18-1376	18-1360	-	18-1353	18-1377	-	18-1396	-
300	1988-95	-	-	-	18-1376	18-1360	-	18-1353	18-1377	-	18-1396	-
2500CC	1988	-	-	-	-	-	-	-	-	-	-	-
2.5L	1982,84-85	-	-	-	-	-	-	-	-	-	-	-
2.6L	1982-86	18-4718	-	-	-	-	-	-	-	-	-	-
V-4 LOOPER												
120	1985	-	-	18-4076	18-1376	18-1360	-	18-1353	18-1377	-	18-1396	-
120	1985-94	-	-	18-4076	18-1376	18-1360	-	18-1353	18-1377	-	18-1396	-
125	1985-94	-	-	18-4076	18-1376	18-1360	-	18-1353	18-1377	-	18-1396	-
140	1985-94	-	-	18-4076	18-1376	18-1360	-	18-1353	18-1377	-	18-1396	-
1.8L	ALL	-	-	18-4076	-	-	-	-	-	-	-	-
V-6 LOOPER												
225	1986-91	-	-	18-4076	18-1376	18-1360	-	18-1353	18-1377	-	18-1396	-
225	1986-93	-	-	18-4076	18-1376	18-1360	-	18-1353	18-1377	-	18-1396	-
2.7L	1987	-	-	18-4076	-	-	-	-	-	-	-	-
275	1985-88	-	-	18-4076	18-1376	18-1360	-	18-1353	18-1377	-	18-1396	-
300	1985-95	-	-	18-4076	18-1376	18-1360	-	18-1353	18-1377	-	18-1396	-

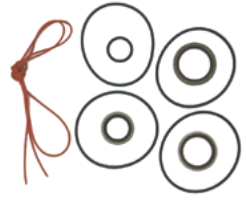
- ① Excepto modelos "D" ③ Modelos tres cilindros ⑤ Modelos 90 grados
 ② Modelos 2 cilindros ④ Modelos 90 grados ⑥ Modelos motores V-4, V-6 & V-8 no incluyen cojinetes en los kits

<p>18-4329 KIT RETENES CIGÜEÑAL Para: 20-35 HP</p>  <table border="1"> <thead> <tr> <th>HP</th> <th>Años</th> <th>HP</th> <th>Años</th> </tr> </thead> <tbody> <tr> <td>20</td> <td>1981-89</td> <td>30</td> <td>1984-89</td> </tr> <tr> <td>25</td> <td>1977-89</td> <td>35</td> <td>1976-89</td> </tr> <tr> <td>28</td> <td>1986-88</td> <td></td> <td></td> </tr> </tbody> </table>	HP	Años	HP	Años	20	1981-89	30	1984-89	25	1977-89	35	1976-89	28	1986-88			<p>18-4330 KIT RETENES CIGÜEÑAL Para: 40-75 HP</p> 	<p>18-4331 KIT RETENES CIGÜEÑAL Para: Crossflow V-4 - V-6</p> 
HP	Años	HP	Años															
20	1981-89	30	1984-89															
25	1977-89	35	1976-89															
28	1986-88																	
<p>18-4332 KIT RETENES CIGÜEÑAL Para: 9.9 - 15 HP</p> 	<p>18-8355 KIT RETENES CIGÜEÑAL Para:</p> <table border="1"> <thead> <tr> <th>Año</th> <th>Modelo/HP</th> <th>1993-96</th> <th>20-35R/25/30TE/20-30E</th> </tr> </thead> <tbody> <tr> <td>1990</td> <td>20-30AC, TE, E/20-35R/25COMM.</td> <td></td> <td></td> </tr> <tr> <td>1991-92</td> <td>25/28/32R, TE, RE</td> <td>1994-96</td> <td>20-30AC,E/25COMM./28</td> </tr> </tbody> </table>	Año	Modelo/HP	1993-96	20-35R/25/30TE/20-30E	1990	20-30AC, TE, E/20-35R/25COMM.			1991-92	25/28/32R, TE, RE	1994-96	20-30AC,E/25COMM./28	<p>18-1286 RETÉN SUPERIOR Reemplaza: 336232 Para: 60° & EFI 90-115HP & 150-175HP</p> 				
Año	Modelo/HP	1993-96	20-35R/25/30TE/20-30E															
1990	20-30AC, TE, E/20-35R/25COMM.																	
1991-92	25/28/32R, TE, RE	1994-96	20-30AC,E/25COMM./28															



***18-7895**
FILTRO ACEITE
 Reemplaza: 778888, 5035703
 200/225 (2004-05)



***18-7896**
187896E Easterner
FILTRO ACEITE
 Reemplaza: 778886, 5033539
 90-115 EFI (2003-05)



***18-7897**
187897E Easterner
FILTRO ACEITE
 Reemplaza: 778887, 5033919
 140 EFI (2003-05)



18-7903
FILTRO ACEITE
 Reemplaza: 5033102, 763364
 9.9-15HP (2002-07)



***18-7915-1**
1879151E Easterner
FILTRO ACEITE
 Reemplaza: 778885, 5031411
 25-70 HP (1998-2005)



***18-7916**
FILTRO ACEITE
 Reemplaza: 434839
 9.9 & 15 HP modelos desde (1995-2001)
 OMC



18-70936
MANGUITO (CABEZA DE CILINDRO, ESTRIBOR)
 Reemplaza: 340975, 321724
 Para: 90 (1994-95), 100 (1996-97), 115 (1994-97), E88 (1996), E90 (1996-98), E100 (1996-97), E112 (1996), E115 (1996-98), J88 (1996), J90 (1996-98), J100 (1997-98), J112 (1996), J115 (1996-98)



18-70937
MANGUITO (CABEZA DE CILINDRO, ESTRIBOR)
 Reemplaza: 340976
 Para: 90 (1994-95), 100 (1996-97), 115 (1994-97), E88 (1996), E90 (1996-98), E100 (1996-97), E112 (1996), E115 (1996-98), J88 (1996), J90 (1996-98), J100 (1997-98), J112 (1996), J115 (1996-98)

— CONTIENE —

Ref #	Desc.	O.E. #	Cant.
18-0933	Junta silenciador	314115	1
18-0935	Junta base	314322	1
18-0951	Junta carburador	317305	1
18-2543	Junta	318609	1
18-0118	Junta carburador	325092	3
18-2913	Junta tapa escape	318609	2
18-2938	Junta tapa escape	331917	1
18-2548	Junta termostato	332108	1
18-2865	Junta adaptador	313763	1
18-0929	Junta termostato	313416	1

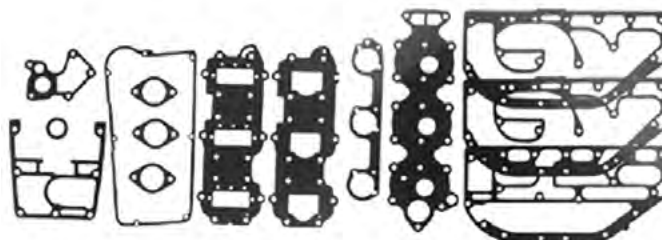

18-4300
KIT JUNTAS MOTOR
 Reemplaza: 385416, 439084

— CONTIENE —

Ref #	Desc.	O.E. #	Cant.
18-2876	Junta tapa	307133	4
18-2866	Junta tapa escape	317914	2
18-0953	Junta	317951	1
18-0117	Junta platina escape	317995	1
18-0955	Junta tapa escape	318156	1
18-2873	Junta tapa cilindro estribor	318335	2
18-0957	Junta adaptador	318373	1
18-2867	Junta colector	319174	1
18-2864	Junta adaptador	321727	1
18-0991	Junta platina	321907	4
18-0134	Junta carburador	327707	2
18-2857	Junta silenciador	386573,	
	a junta carburador	319771	2

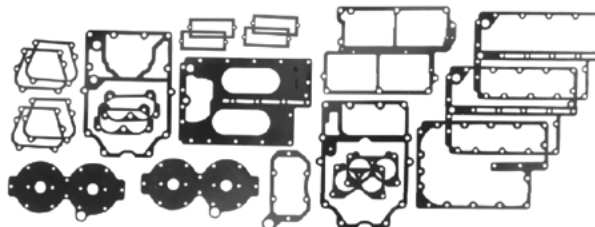

18-4301
KIT JUNTAS MOTOR
 Reemplaza: 388602

* Válvula de anti-drenaje de retorno
 Elimina los arranques en seco, la válvula evita que el aceite retorne al cárter durante el apagado del motor.

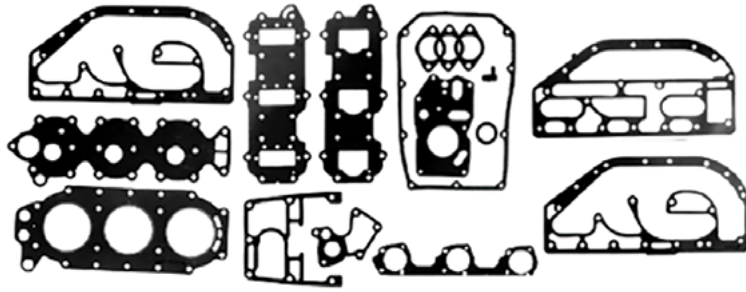

18-4302
KIT JUNTAS MOTOR
 Reemplaza: 390078

- CONTIENE -			
Ref #	Desc.	O.E. #	Cant.
18-2960	Juntas culata	313413	1
18-2865	Junta adaptador	313763	1
18-0951	Junta carburador	317305	1
18-2543	Junta	318609	1
18-0989	Junta silenciador	321794	1
18-0118	Junta carburador	325092	3
18-0102	Junta colector escape	323469	1
18-2913	Junta tapa escape	331916	2
18-2938	Junta tapa escape	331917	1
18-2548	Junta tapa termostato	332108	1
18-0975	Junta carburador	333008	1

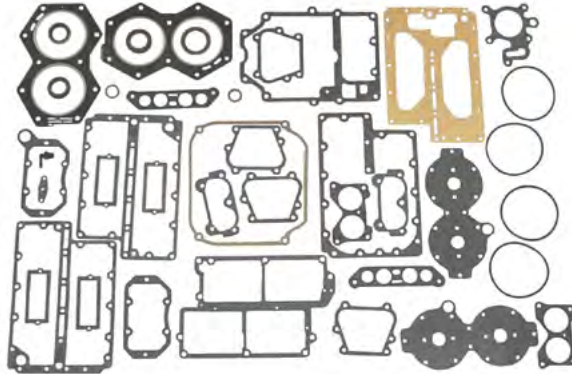

18-4303-1
KIT JUNTAS MOTOR
 Reemplaza: 389556, 391300, 439085

- CONTIENE -			
Ref #	Desc.	O.E. #	Cant.
18-0850	Junta montaje bomba combustible	303615	1
18-2876	Junta tapa	307133	4
18-2866	Junta tapa escape	317914	2
18-0953	Junta	317951	1
18-0117	Junta platina escape	317995	1
18-2873	Junta	318335	2
18-2074	Retén	0339620	1
18-2956	Juntas culata	318358	2
18-2867	Junta colector	319174	1
18-2857	Junta silenciador	386573, 319771	2
18-0985	Junta silenciador	321722	1
18-2864	Junta adaptador	321727	1
18-0991	Junta platina	321907	4
18-2547	Junta tapa	322858	1
18-0102	Junta colector escape	323469	1
18-0134	Junta platina	326926	1
18-0977	Junta termostato	332369	2

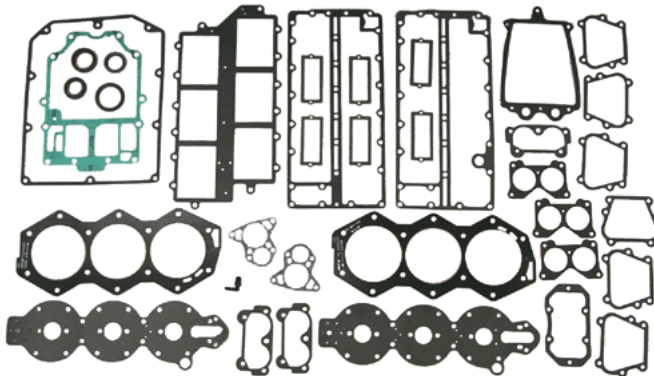

18-4304-1
KIT JUNTAS MOTOR
 Reemplaza: 391988

- CONTIENE -			
Ref #	Desc.	O.E. #	Cant.
18-2549	Junta platina escape	321543	1
18-2876	Junta tapa	307133	6
18-2544	Junta tapa de escape	321028	2
18-2545	Junta platina de escape	321182	1
18-0979	Junta silenciador	321183	1
18-2546	Junta termostato	321184	2
18-0991	Junta platina	321907	6
18-2547	Junta tapa	322858	1
18-0995	Junta adaptador	323222	1
18-0134	Junta carburador	327707	3
18-0148	Junta colector	329718	1
18-2964	Junta culata	320745, 335360, 7667792	
18-2550	Junta culata	323214	1
18-2857	Junta silenciador	386573, 319771	1
18-2001	Retén aceite	330137	1
18-2074	Retén aceite	0339620	2
18-8307	Retén aceite	331103	1

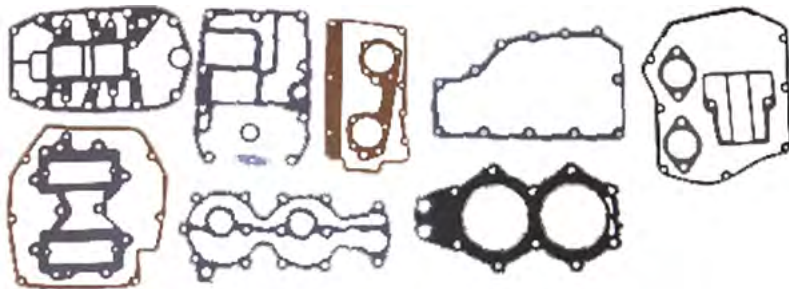

18-4305
KIT JUNTAS MOTOR
 Reemplaza: 393433, 437806, 439083
 Para: sólo modelos 2 cilindros

- CONTIENE -			
Ref #	Desc.	O.E. #	Cant.
18-0851	Junta	329826	1
18-0850	Junta montaje bomba combustible	303615	1
18-0941	Junta tapa	315538	1
18-0118	Junta carburador	325092	2
18-0120	Junta tapa escape	325211	1
18-0128	Junta montaje culata	326468, 351018	1
18-3802	Junta culata	327795, 335359	1
18-0136	Junta montaje culata	328283	1
18-0157	Junta	330698	1
18-0154	Junta	-	1
18-0159	Junta	330909	1
18-0983	Junta carburador	321497	1
18-0182	Junta termostato	310058	1
18-0963	Junta colector	335633	1

— CONTIENE —

Ref #	Desc.	O.E. #	Cant.
18-0850	Junta montaje bomba combustible	303615	1
18-0122	Junta platina	325260	1
18-0961	Junta carburador	318932	1
18-0967	Junta tapa	319332	1
18-0112	Junta montaje culata	324717	1
18-0959	Junta platina	318924	1
18-2907	Junta alojamiento adaptador	325721	1
18-2905	Junta tapa	329920	1
18-2853	Junta tapa escape	318925	2
18-2963	Junta culata	330818	1
18-2879	Junta filtro	331363, 3388761	

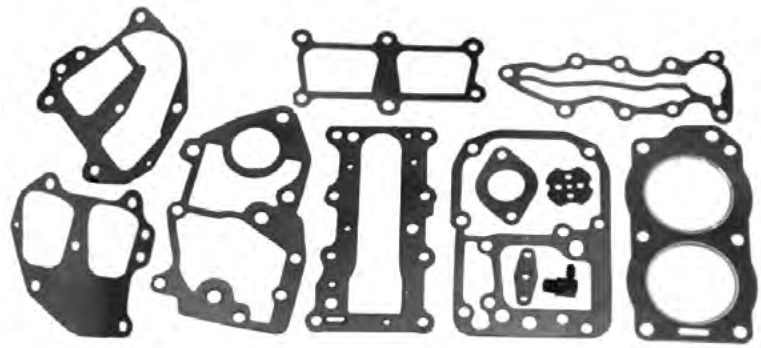

18-4306
KIT JUNTAS MOTOR
Reemplaza: 394546

— CONTIENE —

Ref #	Desc.	O.E. #	Cant.
18-0850	Junta montaje combustible	303615	1
18-0971	Junta	319661	1
18-0981	Junta platina	321479	1
18-0106	Junta colector escape	324323	2
18-0118	Junta carburador	325092	1
18-2862	Junta platina	321573, 326260	1
18-0126	Junta tapa de escape	326264	1
18-2852	Junta inferior bloque	330621	1
18-3803	Junta culata	329419, 765012	1

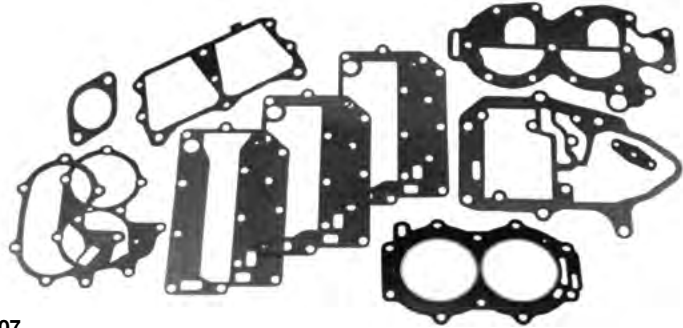

18-4307
KIT JUNTAS MOTOR
Reemplaza: 433941, 392567, 392615, 389206

— CONTIENE —

Ref #	Desc.	O.E. #	Cant.
18-0991	Junta platina	321907	6
18-0995	Junta adaptador	323222	1
18-0134	Junta carburador	327707	3
18-0148	Junta colector	329718	1
18-0979	Junta silenciador	321183	1
18-0945	Junta salida escape	336430	1
18-0927	Junta tapa escape	393561	1
18-2544	Junta tapa	321028	2
18-2546	Junta termostato	321184	2
18-2547	Junta tapa	322858	1
18-2550	Junta culata	323214	1
18-2857	Junta silenciador	386573, 319771	1
18-2876	Junta tapa	307133	6
18-7416	Aro tórico	329380	1
18-7417	Aro tórico	329381	1
18-3801	Juntas culata	325647, 335361	2

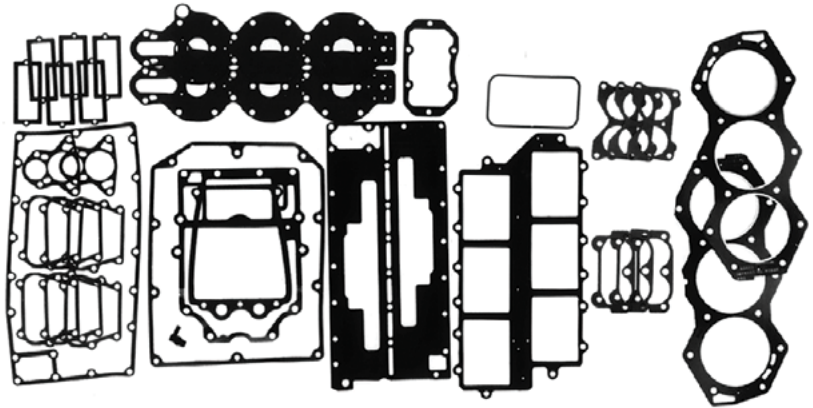

18-4309
KIT JUNTAS MOTOR
Reemplaza: 394885, 434381

— CONTIENE —

Ref #	Desc.	O.E. #	Cant.
18-0142	Junta colector	328622	1
18-0155	Junta montaje rectificador	330412	2
18-0138	Junta adaptador	328590	1
18-0140	Junta	328604	2
18-2074	Retén aceite	0339620	1
18-2075	Retén aceite	0353076	1
18-7418	Retén aceite	326741	4
18-3837	Junta culata	328623	2
18-0978	Junta tapa	331598	2

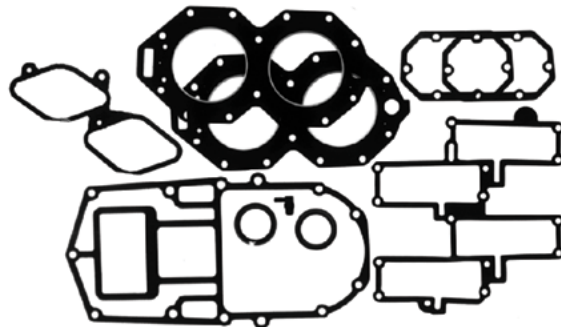

18-4310
KIT JUNTAS MOTOR
Reemplaza: 396750

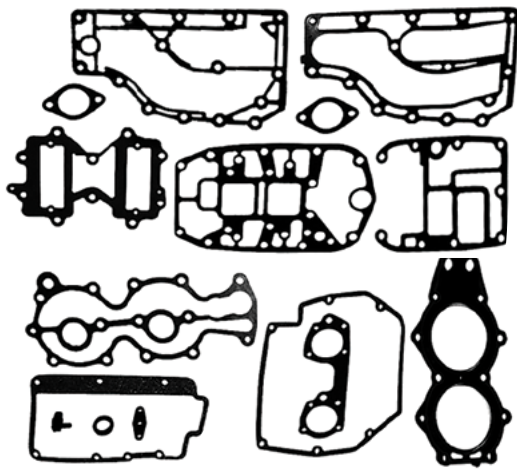

18-4318
KIT JUNTAS MOTOR
 Reemplaza: 390076

— CONTIENE —

Ref #	Desc.	O.E. #	Cant.
18-0963	Junta colector	335633	1
18-0850	Junta montaje rectificador	303615	1
18-0118	Junta carburador	325092	2
18-0983	Junta carburador	321497	1
18-3802	Junta culata	327795, 335359	1
18-0941	Junta tapa	315538	1
18-0157	Junta	330698	1
18-0128	Junta montaje culata	326468, 351018	1
18-0136	Junta montaje culata	328283	1
18-1224	Junta tapa de escape	315869	1
18-1218	Junta tapa de escape	315868	1
18-0182	Retén	310058	1

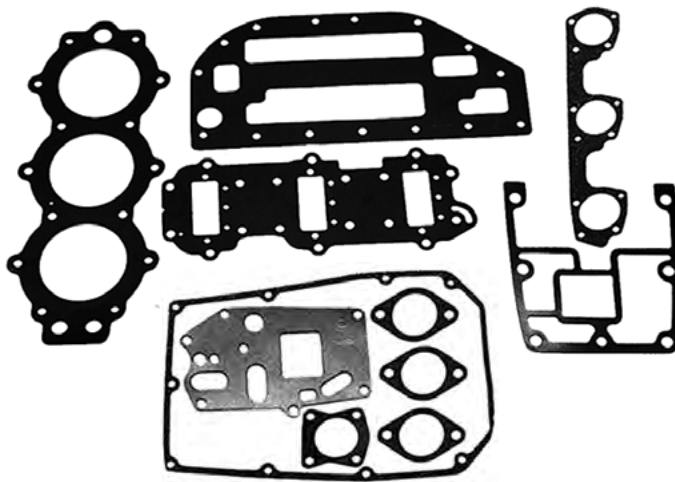

18-4321
KIT JUNTAS MOTOR
 Reemplaza: 398047, 438904

— CONTIENE —

Ref #	Desc.	O.E. #	Cant.
18-0118	Junta carburador	325092	3
18-0989	Junta silenciador	321794	1
18-0975	Junta carburador	333008	1
18-3836	Junta culata	329836	1
18-1202	Junta tapa termostato	329830	1
18-1205	Junta adaptador	329828	1
18-1207	Junta colector escape	329833, 343863	1
18-1212	Junta colector	326926	1
18-1219	Casquillo	320880	1
18-1221	Junta retenedor	330273	1

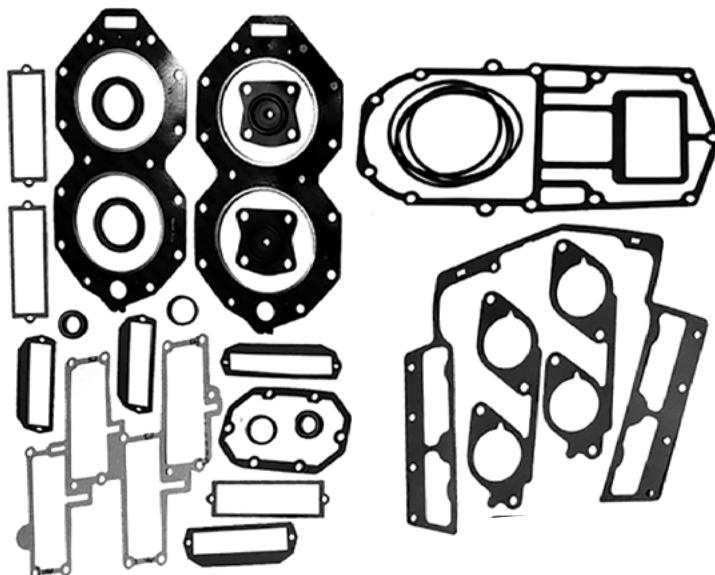

18-4322
KIT JUNTAS MOTOR
 Reemplaza: 432570

— CONTIENE —

Ref #	Desc.	O.E. #	Cant.
18-0987	Junta colector	332319	2
18-0142	Junta colector	328622	1
18-2074	Retén	0339620	1
18-2075	Retén	0353076	1
18-0130	Junta caja	332266	4
18-7418	Aro tórico	326741	4
18-0155	Junta montaje rectificador	330412	1
18-3866	Junta culata	328623, 340115	2
18-0138	Junta adaptador	328590	1
18-0144	Junta caja	328626	4
18-1221	Junta retenedor	330273	2
18-1219	Casquillo	320880	2
18-1222	Junta termostato	394408	2

- CONTIENE -

Ref #	Desc.	O.E. #	Cant.
18-0130	Junta caja	332266	6
18-3839	Juntas culatas	334726, 333670	2
18-0161	Junta colector	331532	1
18-0155	Junta montaje rectificador	330412	1
18-0142	Junta colector	328622	1
18-0987	Junta colector	332319	3
18-0978	Junta tapa	331598	1
18-0965	Junta adaptador	333879	1
18-7418	Aro tórico	326741	4
18-2074	Retén	0339620	1
18-2075	Retén	0353076	2
18-1222	Junta termostato	394408	2
18-1221	Junta retenedor	330273	2
18-1219	Casquillo	320880	2
18-0412	Junta termostato	337068	2

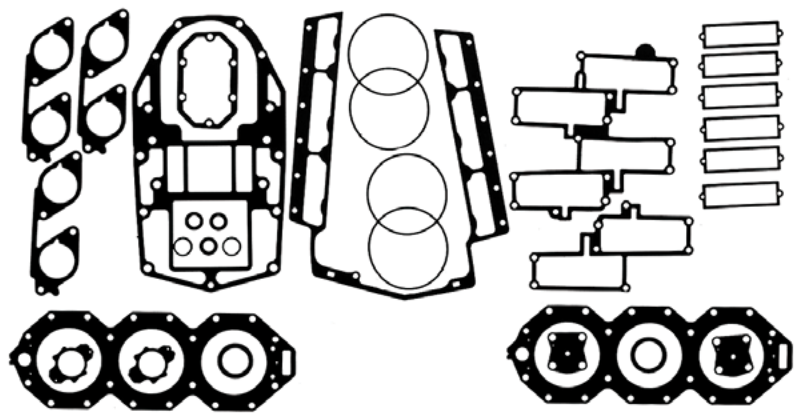

18-4323
KIT JUNTAS MOTOR
 Reemplaza: 436891

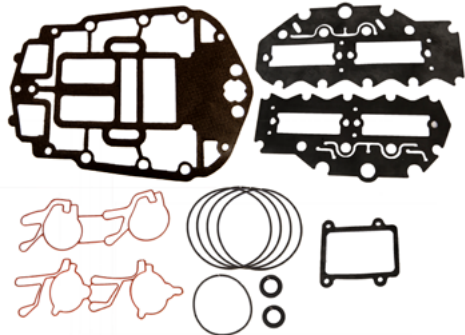

18-4402
KIT JUNTAS MOTOR
 Reemplaza: 437779, 439559
 Para: 90 V4 60 grados (1995-00), 115 V4 60 grados (1995-00)

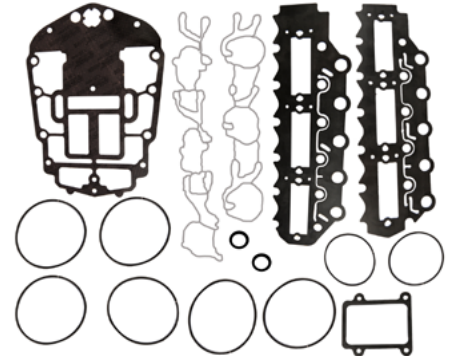

18-4406
KIT JUNTAS MOTOR
 Reemplaza: 437155
 Para: 150 60 grados (1991-00), 175 60 grados (1991-00)

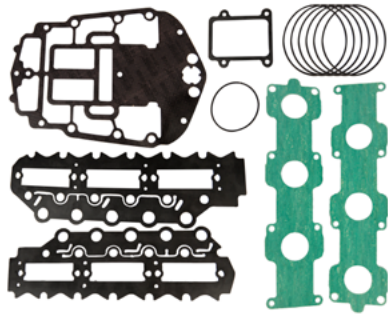

18-4420
KIT JUNTAS MOTOR
 Reemplaza: 439202
 Para: 150 Ficht FFI, 175 Ficht FFI

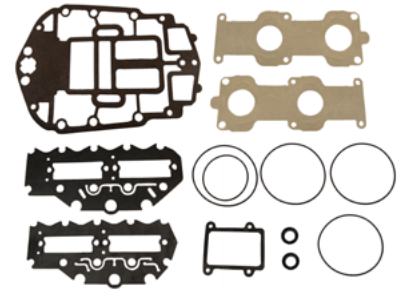

18-4421
KIT JUNTAS MOTOR
 Reemplaza: 5000400
 Para: 90 Ficht FFI, 115 Ficht FFI, 135 Ficht FFI

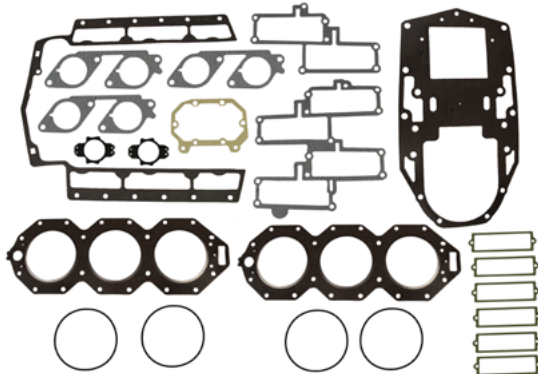

18-4428
KIT JUNTAS MOTOR
 Reemplaza: 437725
 Para: 200 BB (1993 & sup), 225 BB (1993 & sup), 225 Ficht FFI (1999 & sup), 250 solo Carb (2000)

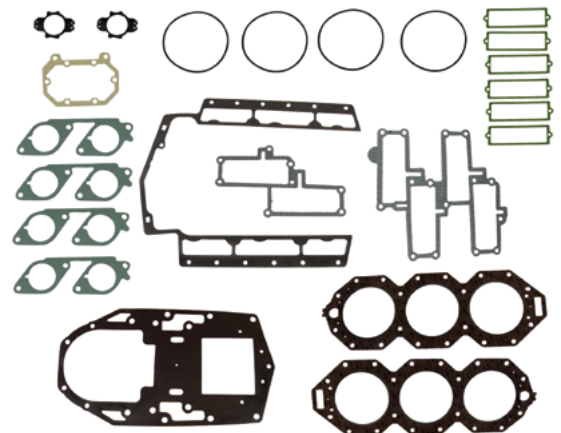

18-4429
JUEGO JUNTAS
 Para: 200 Ficht FFI (1999-01), 225 (2000-04), 250 (2000-04), 3.3L (2000-04)

<p>Pack. de 2</p>  <p>18-2884 18-2884-9① JUNTA CULATA Reemplaza: 313782</p>	<p>Pack. de 2</p>  <p>18-2885 18-2885-9① JUNTA CULATA Reemplaza: 303438</p>	<p>Pack. de 2</p>  <p>18-2888 18-2888-9① JUNTA CULATA Reemplaza: 332010, 326953</p>
 <p>18-2950 JUNTA CULATA Reemplaza: 309612, 766870</p>	 <p>18-2951 JUNTA CULATA Reemplaza: 304720</p>	 <p>18-2952 JUNTA CULATA Reemplaza: 203034</p>
 <p>18-2954 JUNTA CULATA Reemplaza: 319633</p>	 <p>18-2956 JUNTA CULATA Reemplaza: 318358</p>	 <p>18-2957 JUNTA CULATA Reemplaza: 307069</p>
 <p>18-2958 JUNTA CULATA Reemplaza: 315539</p>	 <p>18-2959 JUNTA CULATA Reemplaza: 306048</p>	 <p>18-2960 JUNTA CULATA Reemplaza: 313413</p>
 <p>18-2961 JUNTA CULATA Reemplaza: 329103</p>	 <p>18-2962 JUNTA CULATA Reemplaza: 322332</p>	 <p>18-2963 JUNTA CULATA Reemplaza: 330818, 320533, 318914</p>

① Precio envasado



18-2964
JUNTA CULATA
Reemplaza: 320745, 335360, 766779



18-3800
JUNTA CULATA
Reemplaza: 325273



18-3801
JUNTA CULATA
Reemplaza: 325647, 335361



18-3802
JUNTA CULATA
Reemplaza: 320658, 327795, 335359



18-3803
JUNTA CULATA
Reemplaza: 324324, 329419, 765012
Para: solo 2 cilindros modelos



18-3836
JUNTA CULATA
Reemplaza: 329836



18-3837
JUNTA CULATA
Reemplaza: 328623



18-3838
JUNTA CULATA
Reemplaza: 331211



18-3839
JUNTA CULATA
Reemplaza: 333670, 334726



18-3841-2
JUNTA CULATA
Reemplaza: 203130



18-3898
JUNTA CULATA
Reemplaza: 332819



18-3866
JUNTA CULATA
Reemplaza: 340115, 333549
Para: V-4 Loop Charge



18-3895
JUNTA CULATA
Reemplaza: 332816



18-3896
JUNTA CULATA
Reemplaza: 332817



18-0491
JUNTA CULATA
Reemplaza: 346007
Para: 200 Ficht FFI (1999-01), 225 (2000-04), 250 (2000-04), 3.3L (2000-04)



18-0492
JUNTA CULATA
Reemplaza: 340919, 345257
Para: 200 BB (1993 & sup), 225 BB (1993 & sup), 225 Ficht FFI (1999 & sup) 250 Carb solo (2000)

PACK. DE 12



18-7110
18-7110-9^①
ARO TÓRICO
Reemplaza: 335523
3.960 D.E x 0.103 H
Para: 90/115 HP (1995-98), 100 HP (1998), 105 HP (1997-98), 150/175 HP (1991-97)
90 Ficht FFI, 115 Ficht FFI, 135 Ficht FFI, 150 Ficht FFI, 175 Ficht FFI, 90 V4 60 grados(1995-00),
115 V4 60 grados (1995-00), 150 60 grados(1991-00), 175 60 grados (1991-00)

① Precio envasado

JUNTA CULATA/APLICACIÓN JUEGO JUNTAS













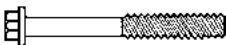
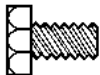
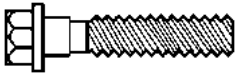

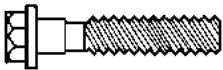





HP	Año	Junta Culata	Junta culata inferior	Juego de juntas	HP	Año	Junta Culata	Junta culata inferior	Juego de Juntas
1.5	1968-70	18-2884	—	—	65 Comm.	1987-95	18-3836	—	18-4321
2, Colt, Jr.	1971-90	18-2884	—	—	65 Jet	1991-95	18-2956 ①	18-3898 ①	18-4303-1
2.5,3,4,4.5, Ultra,Excel 41981-93	1981-93	18-2888	—	—	70	1974-76	18-2960	18-3895	18-4300②
3	1957-68	18-3841-2	—	—	70	1977-85	18-2960	18-3895	18-4302
4	1969-80	18-3841-2	—	—	70	1986-97	18-3836	—	18-4321
4.5	1980	18-3841-2	—	—	75	1960-65	18-2959 ①	—	—
5	1965-68	18-2961	—	—	75	1975	18-2960	18-3895	18-4300②
5	1984-95	18-3800	—	—	75	1977-88	18-2960	18-3895	18-4302
5.5	1957-58	18-2885	—	—	80	1966-67	18-2959 ①	—	—
5.5	1959-64	18-2961	—	—	80 Jet	1991-96	18-2956 ①	18-2956 ①	18-4303-1
6	1965-79	18-2961	—	—	85	1968-72	18-2959 ①	—	—
6	1984-95	18-3800	—	—	85	1979-80,91-95	18-2956①	18-3898 ①	18-4303-1
6.5 Comm.	1989-90	18-3800	—	—	88	1987-95	18-2956 ①	18-3898 ①	18-4303-1
7.5	1957-58	18-2952	—	—	90	1964-65	18-2959 ①	—	—
7.5	1980-93	18-3800	—	—	90	1981-95	18-2956 ①	18-3898 ①	18-4303-1
8	1984-95	18-3800	—	—	100	1966-72	18-2959 ①	—	—
9.5	1964-73	18-2950	—	—	100 ③	1979-95	18-2956 ①	18-3898 ①	18-4303-1
9.9	1974-92	18-2963	—	18-4306②	1600CC	1988	18-2956 ①	18-3898 ①	18-4303-1
10 Comm.	1989-90	18-2963	—	18-4306	110	1986-89	18-2956 ①	18-3898 ①	18-4303-1
14	1988-90	18-2963	—	18-4306	115	1969-70	18-2959 ①	—	—
15	1974-92	18-2963	—	18-4306④	115	1973-77	18-2956 ①	18-3898 ①	—
18	1959-73	18-2962	—	—	115	1978-95	18-2956 ①	18-3898 ①	18-4303-1
18 Jet	1995-98	18-3803	—	18-4307	120	1985-87	18-3837 ①	—	18-4310
20	1981-99	18-3803	—	18-4307	120	1988-94	18-3866 ①	—	18-4322
25	1969-76	18-2962	—	—	125 Comm.	1992-95	18-3866 ①	—	18-4322
25	1977-78	18-2954	—	—	130	1995-98	18-3866 ①	—	18-4322
25 ⑤	1979-03	18-3803	—	18-4307	135	1973-76	18-2956 ①	18-3898 ①	18-4301
28	1986-96	18-3803	—	18-4307	140	1977	18-2956 ①	18-3898 ①	18-4301
30 ⑤	1984-03	18-3803	—	18-4307	140	1978-84	18-2956 ①	18-3898 ①	18-4303-1
33	1965-70	18-2951	—	—	140	1985-87	18-3837 ①	—	18-4310
35	1957-58	18-2951	—	—	140	1988-94	18-3866 ①	—	18-4322
35	1976-78	18-2954	—	—	150	1973-91	18-2964 ①	18-3896 ①	18-4304-1
35	1979-88	18-3803	—	18-4307	155 Comm.	1984-92	18-2964 ①	18-3896 ①	18-4304-1
35 ⑥	1987	18-3802	—	18-4305	2500CC	1988	18-2964 ①	18-3896 ①	18-4304-1
40	1960-80	18-2957	—	—	175	1977-83	18-2964 ①	18-3896 ①	18-4304-1
40 Comm.	1981-90	18-2957	—	18-4324	175	1986-91	18-3801 ①	18-3897 ①	18-4309
40	1984-97	18-3802	—	18-4305	185	1984-85	18-2964 ①	18-3896 ①	18-4304-1
40 Comm.	1994-97	18-3802	—	18-4305	185	1990-93	18-3839 ①	—	18-4323
45 Comm.	1985-97	18-3802	—	18-4305	200	1976-83	18-2964 ①	18-3896 ①	18-4304-1
45SS	1987-90	18-3802	—	—	200	1986-87	18-3838 ①	—	—
48	1987-97	18-3802	—	18-4305	200 ③	1988-93	18-3839 ①	—	18-4323
50	1958-59	—	—	—	225	1986-87	18-3838 ①	—	—
50	1971-75	18-2958	—	18-4305⑦	225	1988-93	18-3839 ①	—	18-4323
50	1979-80	18-3802	—	18-4318	235	1986-87	18-3838 ①	—	—
50	1981-97	18-3802	—	18-4305	235	1988-93	18-3839 ①	—	18-4323
55	1968-69	18-2960	18-3895	—	275/3.6L	1985-87	18-3840 ①	—	—
55	1977-79	18-3802	—	18-4318	OMC SEA DRIVE				
55	1980-97	18-3802	—	18-4305	HP	Año	Junta Culata	Junta culata inferior	Juego de juntas
55	1995	18-3802	—	—	1.6L	1983-90	18-2956	18-3898 ①	18-4303-1
60	1970-71	18-2960	18-3895	—	1.8L	1987	18-3837	-	-
60	1980-85	18-3802	—	18-4305	2.0L	1988-90	18-3866①	-	18-4322
60	1986-88	18-2960	18-3895	18-4302	2.5L	1982,84-85	18-2964	18-3896①	18-4304-1
60	1989-97	18-3836	—	18-4321	2.6L	1982-86	18-3801①	18-3897①	-
SST60	1989-90	18-3836	—	—	2.7L	1987	18-3838	-	-
65	1968	—	—	—	3.0L	1988-90	18-3839	-	-
65	1972-73	18-2960	18-3895	18-4300⑧	3.6L	1987	18-3840	-	-
65 Comm.	1984-86	18-2960	—	18-4302					

① Requiere dos juntas culata por motor
 ② Sólo modelos con sufijo G y H 1976
 ③ También modelos comerciales

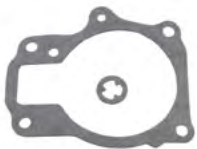
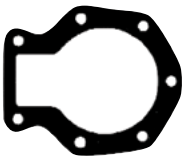
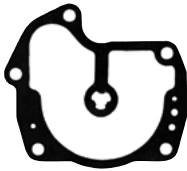





















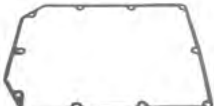
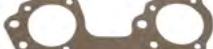

④ Sólo modelos con sufijo 1976 A
 ⑤ Sólo para modelos 2 cilindros
 ⑥ Sólo modelos con sufijo D

⑦ Se requiere junta culata 18-29585 para completar el juego
 ⑧ Junta culata no disponible en el juego de juntas

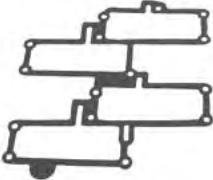















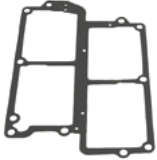
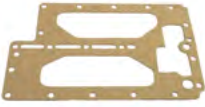

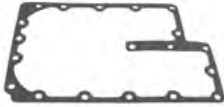

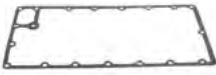

TORNILLOS ACERO INOXIDABLE

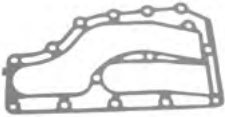
 <p>18-3133 Reemplaza: 331979 1/4" x 20 x 1 1/16" HEXAGONAL Para: motores arranque, alojamientos bomba de agua y unidades jet-drive</p>	<p>Pack. de 2</p>  <p>18-3135 18-3135-9① Reemplaza: 306643 1/8" x 20 x 1 1/2" RANURA Para: Ánodos para partes inferiores, tapas encendido y alojamiento bombas de agua</p>	<p>Pack. de 2</p>  <p>18-3136 18-3136-9① Reemplaza: 323626 1/4" x 20 x 1 3/4" HEXAGONAL CON BASE PLANA Para: Alojamiento bombas de agua, tapas escape, colectores, bobinas de encendido</p>	 <p>18-3153 Reemplaza: 908158 1/4" x 20 x 1 1/2" HEX Para: Ánodos parte inferior soporte cojinetes. Tapas 45 HP y superiores cobra, tapa motor inferior 5 HP</p>	
 <p>18-3365 Reemplaza: 909533 1/4" x 20 x 1" HEXAGONAL CON BASE PLANA Para: Tapas volante e interiores y mas</p>	 <p>18-3369 Reemplaza: 302325 1/4" x 20 x 1" HEXAGONAL Para: Impulsor alojamiento, bobina encendido, tapa escape, abrazaderas de starter</p>	<p>Pack. de 5</p>  <p>18-4276 18-4276-9① Reemplaza: 324334 1/4" x 20 x 1 1/32" HEXAGONAL BASE PLANA Para: bomba agua, tapa escape, bobinas de encendido, colectores</p>	<p>TIPO CABEZA</p>  <p>HEXAGONAL C/ BASE PLANA</p>  <p>HEXAGONAL</p>  <p>RANURA</p>  <p>FILLISTER</p>	
<p>Pack. de 2</p>  <p>18-0118 18-0118-9① JUNTA CARBURADOR Reemplaza: 325092</p>	<p>Pack. de 2</p>  <p>18-0134 18-0134-9① V-4 & V-6 JUNTA CARBURADOR Reemplaza: 327707</p>	<p>Pack. de 2</p>  <p>18-0961 18-0961-9① JUNTA MONTAJE CARBURADOR Reemplaza: 318932</p>	 <p>18-0437 JUNTA TAPA Reemplaza: 334353</p>	 <p>18-0628 JUNTA TAPA Reemplaza: 341501</p>
 <p>18-0626 JUNTA TAPA Reemplaza: 334043</p>	 <p>18-1241 JUNTA TAZA FLOTADOR Y AGUJA</p>	 <p>18-2579 JUNTA FLOTADOR Reemplaza: 338882</p>	 <p>18-2582 JUNTA CARBURADOR Reemplaza: 338813</p>	 <p>18-8352 JUNTA CARBURADOR Reemplaza: 332253</p>
<p>Pack. de 2</p>  <p>18-2890 18-2890-9① JUNTA FLOTADOR Reemplaza: 331203, 338886, 302994</p>	<p>Pack. de 2</p>  <p>18-2893 18-2893-9① JUNTA FLOTADOR Reemplaza: 303750</p>	<p>Pack. de 2</p>  <p>18-2903 18-2903-9① JUNTA FLOTADOR Reemplaza: 332696, 338880</p>	<p>Pack. de 2</p>  <p>18-2906 18-2906-9① JUNTA FLOTADOR Reemplaza: 333418, 333884, 338884 V-4, V-6</p>	<p>Pack. de 2</p>  <p>18-2908 18-2908-9① JUNTA FLOTADOR Reemplaza: 331499, 338878</p>

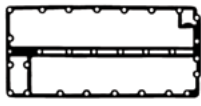

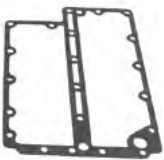

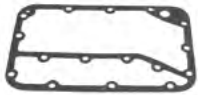













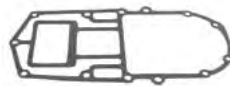

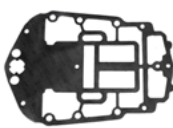
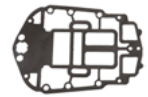

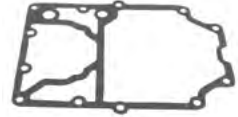
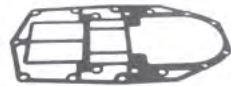

① Precio por pack

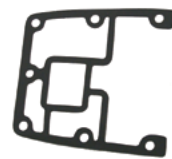
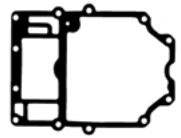
<p>Pack. de 2</p>  <p>18-0850 18-0850-9① JUNTA BOMBA COM- BUSTIBLE Reemplaza: 303615</p>	<p>Pack. de 2</p>  <p>18-2879 18-2879-9① JUNTA BOMBA COM- BUSTIBLE Reemplaza: 331363, 338876, 312634</p>	<p>Pack. de 2</p>  <p>18-2900 18-2900-9① JUNTA BOMBA COM- BUSTIBLE Reemplaza: 332694, 338879, 312679</p>	<p>Pack. de 2</p>  <p>18-2889 18-2889-9① JUNTA FILTRO Reemplaza: 302675</p>	<p>Pack. de 2</p>  <p>18-2892 18-2892-9① JUNTA FILTRO Reemplaza: 303355</p>
 <p>18-0140 JUNTA Reemplaza: 328604</p>	 <p>18-0157 JUNTA Reemplaza: 330698</p>	 <p>18-0159 JUNTA Reemplaza: 330909</p>	 <p>18-0933 JUNTA Reemplaza: 314115 70/75 HP</p>	 <p>18-0935 JUNTA BASE Reemplaza: 314322 70/75 HP</p>
<p>Pack. de 2</p>  <p>18-0975 18-0975-9① JUNTA CARBURADOR Reemplaza: 333008 3 Cil.</p>	 <p>18-0978 JUNTA A TAPA Reemplaza: 331598 Para: 185, 200 & 225 H.P., V-6</p>	<p>Pack. de 2</p>  <p>18-0979 JUNTA SILENCIADOR Reemplaza: 321183 V-6</p>	 <p>18-0983 18-0983-9① JUNTA Reemplaza: 321497</p>	 <p>18-0985 JUNTA SILENCIADOR Reemplaza: 321722 V-4</p>
 <p>18-0989 JUNTA SILENCIADOR Reemplaza: 321794 3 Cil.</p>	<p>Pack. de 2</p>  <p>18-2857 18-2857-9① JUNTA SILENCIADOR Reemplaza: 386573, 319771</p>	<p>Pack. de 2</p>  <p>18-0122 18-0122-9① 9.9 & 15 HP JUNTA Reemplaza: 325260</p>	<p>Pack. de 2</p>  <p>18-0130 18-0130-9① JUNTA CAJA Reemplaza: 332266 Para: V-4, V-6 & V-8</p>	 <p>18-0142 JUNTA COLECTOR Reemplaza: 328622</p>
<p>Pack. de 2</p>  <p>18-0144 18-0144-9① JUNTA CAJA Reemplaza: 328626 Para: 120-140 H.P V-4</p>	 <p>18-0148 JUNTA COLECTOR Reemplaza: 329718 V-6</p>	 <p>18-0161 JUNTA COLECTOR INFERIOR Reemplaza: 331532 Para: V-6</p>	<p>Pack. de 2</p>  <p>18-0959 18-0959-9① JUNTA PLATINA Reemplaza: 318924 9.9 & 15 HP</p>	<p>Pack. de 2</p>  <p>18-0963 18-0963-9① JUNTA COLECTOR DOBLE Reemplaza: 335633</p>

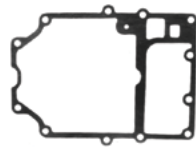
① Precio por pack

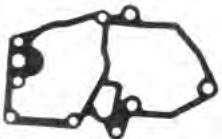
<p>Pack. de 2</p>  <p>18-0981 18-0981-9① JUNTA PLATINA Reemplaza: 321479 25 & 35 HP</p>	<p>Pack. de 2</p>  <p>18-0987 18-0987-9① JUNTA CUERPO DE ACELERACIÓN Reemplaza: 332319</p>	<p>Pack. de 2</p>  <p>18-0991 18-0991-9① JUNTA PLATINA Reemplaza: 321907 V-4/V-6</p>	<p>Pack. de 2</p>  <p>18-0973 18-0973-9① JUNTA CARBURADOR Reemplaza: 315052 V-4 Incluye montaje carburador: 100, 115, 125, 135, 140, 150, 175, 200, 235(1977-79), 85 (1969-79)</p>	 <p>18-1212 JUNTA COLECTOR Reemplaza: 326926 Para: 3 cil.</p>
<p>Pack. de 2</p>  <p>18-2862 18-2862-9① JUNTA PLATINA Reemplaza: 321573, 326260 25/35 HP</p>	<p>Pack. de 2</p>  <p>18-2867 18-2867-9① JUNTA COLECTOR Reemplaza: 319174 Para: V-4</p>	 <p>18-0102 JUNTA COLECTOR ESCAPE Reemplaza: 323469 V-4</p>	<p>Pack. de 2</p>  <p>18-0106 18-0106-9① JUNTA COLECTOR ESCAPE Reemplaza: 324323 25/35</p>	 <p>18-0117 JUNTA PLATINA ESCAPE Reemplaza: 317955 V-4</p>
 <p>18-0120 JUNTA PLATINA ESCAPE Reemplaza: 325211</p>	<p>Pack. de 2</p>  <p>18-0126 18-0126-9① JUNTA TAPA ESCAPE Reemplaza: 326264</p>	 <p>18-0945 JUNTA ESCAPE EXTERIOR Reemplaza: 336430, 323217</p>  <p>18-0927 JUNTA TAPA ESCAPE 235 HP Reemplaza: 393561</p>	<p>Pack. de 2</p>  <p>18-0999-9① JUNTA ESCAPE Reemplaza: 323459 V-4</p>	 <p>18-0955 JUNTA TAPA ESCAPE Reemplaza: 318156 V-4</p>
 <p>18-1207 JUNTA COLECTOR ESCAPE Reemplaza: 329833, 343863</p>	 <p>18-1218 JUNTA TAPA ESCAPE Reemplaza: 315868</p>	 <p>18-1224 JUNTA TAPA ESCAPE Reemplaza: 315869</p>	<p>Pack. de 2</p>  <p>18-2545 18-2545-9① JUNTA PLATINA ESCAPE Reemplaza: 321182 V-6</p>	<p>Pack. de 2</p>  <p>18-2549 18-2549-9① JUNTA TAPA ESCAPE Reemplaza: 321435 V-6</p>
<p>Pack. de 2</p>  <p>18-2853 18-2853-9① JUNTA TAPA ESCAPE Reemplaza: 318925 9.9/15 HP</p>	<p>Pack. de 2</p>  <p>18-2866 18-2866-9① JUNTA TAPA ESCAPE Reemplaza: 317914 V-4</p>	<p>Pack. de 2</p>  <p>18-2870 18-2870-9① JUNTA TAPA ESCAPE Reemplaza: 305176</p>	<p>Pack. de 2</p>  <p>18-2871 18-2871-9① JUNTA TAPA ESCAPE Reemplaza: 304762</p>	<p>Pack. de 2</p>  <p>18-2886 18-2886-9① JUNTA TAPA ESCAPE Reemplaza: 203171</p>

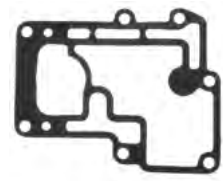
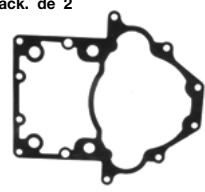













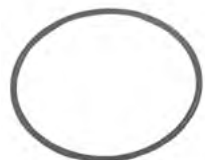

① Precio por pack

<p>Pack. de 2</p>  <p>18-2913 18-2913-9① JUNTA TAPA ESCAPE Reemplaza: 331916, 319097 3 Cil.</p>	<p>Pack. de 2</p>  <p>18-2938 18-2938-9① JUNTA TAPA ESCAPE Reemplaza: 331917 3 Cil.</p>	 <p>18-1283 JUNTA ADMISION Reemplaza: 335818 Para: V6 60° Eagle Series, 90-115 HP (1995-00)</p>	 <p>18-1284 JUNTA ADMISION Reemplaza: 335819 Para: V6 60° Eagle Series 90-115 HP (1995-00)</p>	 <p>18-1285 JUNTA ENTRADA BABOR Reemplaza: 335403 Para: V6 60° Eagle series 150-175HP (1991-00)</p>
 <p>18-0112 JUNTA BASE MOTOR Reemplaza: 324717 9.9 & 15 HP</p>	 <p>18-0128 JUNTA BASE MOTOR Reemplaza: 326468, 351018</p>	 <p>18-0136 JUNTA BASE MOTOR Reemplaza: 328283</p>	 <p>18-0138 JUNTA BASE MOTOR Reemplaza: 328590</p>	 <p>18-0690 JUNTA BASE Reemplaza: 347205 Para: 200 BB (1993 & sup), 200 Ficht FFI (1999-01), 225 BB (1993 & sup), 225 Ficht FFI (1999 & sup), 225 (2000-04), 250 sólo Carb (2000), 250 (2000-04), 3.3L (2000-04)</p>
 <p>18-0691 JUNTA BASE Para: 150 Ficht FFI , 175 Ficht FFI</p>	 <p>18-0692 JUNTA BASE Reemplaza: 339601 Para: 90 V4 60 grados (1995-00), 90 Ficht FFI, 1150V4 60 grados (1995-00), 115 Ficht FFI, 135 Ficht FFI, 150 60 grados (1991-00), 175 60 grados (1991-00)</p>	 <p>18-0693 JUNTA ADMISION Reemplaza: 336227 Para: 135(2005-06), 150(1991-98), 150(1991-06), 175(1991-06)</p>	 <p>18-0694 JUNTA ADMISION Reemplaza: 336226 Para: 135(2005-06), 150(1991-05), 175(1991-05)</p>	 <p>18-0695 JUNTA ADMISION Reemplaza: 336389 Para: 90(1995-06), 115(1995-06), 100(1998-01, 2005)</p>
 <p>18-0696 JUNTA ADMISION Reemplaza: 336388 Para: 90(1995-06), 100(1998-01, 2005), 115(1995-06)</p>	 <p>18-0957 JUNTA BASE MOTOR Reemplaza: 318373</p>	 <p>18-0965 JUNTA Reemplaza: 333879</p>	 <p>18-0995 JUNTA BASE MOTOR Reemplaza: 323222 V-6</p>	<p>Pack. de 2</p>  <p>18-1205 18-1205-9① JUNTA TAPA Reemplaza: 329828</p>
<p>Pack. de 2</p>  <p>18-2550 18-2550-9① JUNTA BASE MOTOR Reemplaza: 323214 V-6</p>	<p>Pack. de 2</p>  <p>18-2852 18-2852-9① JUNTA BASE MOTOR Reemplaza: 330621 25/35 HP</p>	<p>Pack. de 2</p>  <p>18-2864 18-2864-9① JUNTA BASE MOTOR Reemplaza: 321727 V-4</p>	<p>Pack. de 2</p>  <p>18-2865 18-2865-9① JUNTA BASE MOTOR Reemplaza: 313763 3 Cil.</p>	<p>Pack. de 2</p>  <p>18-2868 18-2868-9① JUNTA BASE MOTOR Reemplaza: 310137 35/40 HP</p>
<p>Pack. de 2</p>  <p>18-2877 18-2877-9① JUNTA Reemplaza: 314421 18/25 HP</p>	<p>Pack. de 2</p>  <p>18-2878 18-2878-9① JUNTA Reemplaza: 319710 25/35</p>	<p>Pack. de 2</p>  <p>18-2894 18-2894-9① JUNTA ALOJAMIENTO ESCAPE Reemplaza: 304314</p>	<p>Pack. de 2</p>  <p>18-2898 18-2898-9① JUNTA ALOJAMIENTO ESCAPE Reemplaza: 309956 V-4</p>	<p>Pack. de 2</p>  <p>18-2901 18-2901-9① JUNTA ALOJAMIENTO ESCAPE Reemplaza: 313065, 306205 5, 5.5, 6 HP</p>

① Precio por pack

<p>Pack. de 2</p>  <p>18-2904 18-2904-9 ① JUNTA PLATINA ESCAPE Reemplaza: 319348 28, 33, 40 HP</p>	<p>Pack. de 2</p>  <p>18-2907 18-2907-9 ① JUNTA ALOJAMIENTO ESCAPE Reemplaza: 325721</p>	<p>Pack. de 2</p>  <p>18-0967 18-0967-9 ① JUNTA Reemplaza: 319332 9.9 & 15 HP</p>	<p>Pack. de 2</p>  <p>18-0971 JUNTA Reemplaza: 319661 25 & 35 HP</p>	
<p>Pack. de 2</p>  <p>18-2876 18-2876-9 ① BYPASS COVER GASKET Reemplaza: 307133</p>	<p>Pack. de 2</p>  <p>18-0941 JUNTA Reemplaza: 315538 50/55 HP</p>	<p>Pack. de 2</p>  <p>18-2543 18-2543-9 ① JUNTA Reemplaza: 318609 3 Cil.</p>	<p>Pack. de 2</p>  <p>18-0892 MANGUERA Reemplaza: 322411</p>	
<p>Pack. de 2</p>  <p>18-2544 18-2544-9 ① JUNTA Reemplaza: 321028 V-6</p>	<p>Pack. de 2</p>  <p>18-2856 18-2856-9 ① JUNTA Reemplaza: 319665 25/35 HP</p>	<p>Pack. de 2</p>  <p>18-3899 JUNTA TAPA AGUA Reemplaza: 327674 Para: 20, 25, 25C, 30, 35</p>	<p>Pack. de 2</p>  <p>18-2872 18-2872-9 ① JUNTA CILINDRO BABOR Reemplaza: 307257, 318334 V-4</p>	<p>Pack. de 2</p>  <p>18-2873 18-2873-9 ① JUNTA Reemplaza: 318335 V-4</p>
<p>Pack. de 2</p>  <p>18-2905 18-2905-9 ① JUNTA TAPA AGUA Reemplaza: 329920 9.9, 15 HP</p>	<p>Pack. de 2</p>  <p>18-3360 JUNTA ALOJAMIENTO IMPULSOR Reemplaza: 329390 20-25 HP</p>	<p>Pack. de 2</p>  <p>18-0182 18-0182-9 ① JUNTA TERMOSTATO Reemplaza: 310058</p>	<p>Pack. de 2</p>  <p>18-0397 JUNTA TERMOSTATO Reemplaza: 318917</p>	<p>Pack. de 2</p>  <p>18-0412 18-0412-9 ① JUNTA TERMOSTATO Reemplaza: 337068</p>
<p>Pack. de 2</p>  <p>18-0441 18-0441-9 ① JUNTA TERMOSTATO Reemplaza: 329076</p>	<p>Pack. de 2</p>  <p>18-0929 18-0929-9 ① JUNTA TERMOSTATO Reemplaza: 313416 3 Cil.</p>	<p>Pack. de 2</p>  <p>18-0675 JUNTA TERMOSTATO Reemplaza: 321932 V-4</p>	<p>Pack. de 2</p>  <p>18-0977 18-0977-9 ① JUNTA TERMOSTATO Reemplaza: 332369 V-4</p>	<p>Pack. de 2</p>  <p>18-1202 18-1202-9 ① JUNTA TERMOSTATO Reemplaza: 329830</p>

① Precio por pack

 <p>18-1222 JUNTA TERMOSTATO Reemplaza: 394408</p>	<p>Pack. de 2</p>  <p>18-2547 18-2547-9 ① JUNTA PASO DE AGUA Reemplaza: 322858 V-4/V-6</p>	<p>Pack. de 2</p>  <p>18-2548 18-2548-9 ① JUNTA TERMOSTATO Reemplaza: 332108 3 Cil.</p>	<p>Pack. de 2</p>  <p>18-2546 18-2546-9 ① JUNTA TERMOSTATO Reemplaza: 321184 V-6</p>	<p>Pack. de 2</p>  <p>18-0124 18-0124-9 ① JUNTA IMPULSOR PLATINA Reemplaza: 325537</p>
<p>Pack. de 2</p>  <p>18-0445 18-0445-9 ① JUNTA BOMBA AGUA Reemplaza: 323312 35HP</p>	<p>Pack. de 2</p>  <p>18-0446 JUNTA BOMBA AGUA Reemplaza: 323311 35HP</p>	<p>Pack. de 2</p>  <p>18-0969 18-0969-9 ① JUNTA ALOJAMIENTO IMPULSOR Reemplaza: 319586</p>	<p>Pack. de 5</p>  <p>18-2536 18-2536-9 ① RETÉN ALOJAMIENTO IMPULSOR Reemplaza: 321120 V-4, V-6</p>	<p>Pack. de 5</p>  <p>18-2539 18-2539-9 ① RETÉN GOMA Reemplaza: 328753</p>
<p>Pack. de 2</p>  <p>18-2557 18-2557-9 ① JUNTA IMPULSOR Reemplaza: 324701, 338484 V-4, V-6, V-8</p>	<p>Pack. de 2</p>  <p>18-2709 18-2709-9 ① JUNTA PLATINA DESGASTE Reemplaza: 336530</p>	<p>Pack. de 2</p>  <p>18-0679 JUNTA TERMOSTATO Reemplaza: 311145</p>	<p>Pack. de 2</p>  <p>18-7428 18-7428-9 ① ARO TÓRICO Reemplaza: 307103</p>	<p>Pack. de 2</p>  <p>18-7481 18-7481-9 ① ARO TÓRICO Reemplaza: 324981</p>
<p>Pack. de 2</p>  <p>18-0155 18-0155-9 ① JUNTA MONTAJE RECTI- FICADOR Reemplaza: 330412</p>	<p>Pack. de 2</p>  <p>18-0851 18-0851-9 ① JUNTA Reemplaza: 329826</p>	<p>Pack. de 2</p>  <p>18-0953 18-0953-9 ① JUNTA Reemplaza: 317951 V-4/V-6</p>	<p>Pack. de 2</p>  <p>18-0110 18-0110-9 ① JUNTA Reemplaza: 324670</p>	<p>Pack. de 2</p>  <p>18-0313 JUNTA VARILLA Reemplaza: 352165 Para: E-Tec 75/90/115/150/ 175/200/225/250 HP</p>
<p>Pack. de 2</p>  <p>18-0882 18-0882-9 ① JUNTA VARILLA Reemplaza: 304764</p>	<p>Pack. de 2</p>  <p>18-2855 18-2855-9 ① JUNTA TAPA Reemplaza: 314082</p>	<p>Pack. de 2</p>  <p>18-2874 18-2874-9 ① JUNTA TAPA SOLENOIDE Reemplaza: 314876 V-4</p>	<p>Pack. de 2</p>  <p>18-2880 18-2880-9 ① JUNTA TAPA PLATINA Reemplaza: 304023</p>	<p>Pack. de 2</p>  <p>18-0108 18-0108-9 ① JUNTA CAJA ENGRANAJES Reemplaza: 324449</p>

① Precio por pack

 <p>18-0540 RETÉN GOMA Reemplaza: 320936</p>	<p>Pack. de 2</p>  <p>18-0949 18-0949-9① JUNTA TAPA Reemplaza: 316499</p>	 <p>18-2537 RETÉN GOMA Reemplaza: 324937</p>	<p>Pack. de 2</p>  <p>18-2869 18-2869-9① JUNTA ALOJA- MIENTO ESCAPE Reemplaza: 305312</p>	<p>Pack. de 2</p>  <p>18-2891 18-2891-9① JUNTA ALOJAMIENTO COJINETE Reemplaza: 303339 6HP</p>
 <p>18-8353 RETÉN ACEITE Reemplaza: 320961</p>	 <p>18-1219 CASQUILLO Reemplaza: 320880</p>	 <p>18-2389 CASQUILLO Reemplaza: 314832</p>	 <p>18-2391 CASQUILLO Reemplaza: 321692</p>	 <p>18-2392 CASQUILLO Reemplaza: 327035</p>
<p>Pack. de 2</p>  <p>18-2703 18-2703-9① CASQUILLO Reemplaza: 314008</p>	 <p>18-2704 CASQUILLO Reemplaza: 320943</p>	<p>Pack. de 2</p>  <p>18-2706 18-2706-9① CASQUILLO Reemplaza: 321008</p>	<p>Pack. de 2</p>  <p>18-2708 18-2708-9① CASQUILLO Reemplaza: 333758</p>	 <p>18-3329 CASQUILLO Reemplaza: 302497 9.9-35 HP</p>
 <p>18-3332 CASQUILLO Reemplaza: 304026</p>	 <p>18-3337 CASQUILLO Reemplaza: 315837 40-50 HP</p>	<p>Pack. de 2</p>  <p>18-1221 18-1221-9① JUNTA RETENEDOR Reemplaza: 330273</p>	 <p>18-2532 RETÉN TAPA Reemplaza: 305762 2 Cil.</p>	 <p>18-2534 RETÉN 40" Reemplaza: 309044 Material equivalente a la bobina # 309044 0.1005 D.E.</p>
 <p>18-7963 ARO TÓRICO Reemplaza: 331353</p>	<p>Pack. de 2</p>  <p>18-2705 18-2705-9① RETÉN ACEITE Reemplaza: 315748</p>	<p>Pack. de 2</p>  <p>18-2769 18-2769-9① RETÉN GOMA Reemplaza: 332000</p>	<p>Pack. de 2</p>  <p>18-0917 JUNTA MOTOR TILT Reemplaza: 311508</p>	 <p>18-8372 RETÉN Reemplaza: 323582 Para: 5 & 7.5 HP (1978-83) fuera bordas</p>

Pack. de 2



18-2881
18-2881-9^④
JUNTA ALOJAMIENTO
Reemplaza: 332403,125530
Para: 6 Gallon tanque combustible

Pack. de 2



18-2887
18-2887-9^④
JUNTA TANQ. COMB.
Reemplaza: 302557



18-1704
TORNILLO
Reemplaza: 331980
Para: Waterpumps, power packs,
(1985-96)



18-4904
**ARRANQUE UNIVERSAL,
CUERDA Y MANETA**
(Usa 9/64" cuerda)
maneta: 18-4901

CUERDA STARTER



18-4911
5/32" x 200'
Reemplaza: 322236, 772577

18-4913
3/16" x 200'
Reemplaza: 316705, 772578

18-4914
1/8" x 200'
Reemplaza: 316706, 772579



18-1505
ENGRANAJES
Reemplaza: 318940
Para: 9.9 - 15HP
(1974-1992)



18-6501
MUELLE DE ARRANQUE
Reemplaza: 395460, 307573



18-6503
MUELLE DE ARRANQUE
Reemplaza: 318944



18-6509
MUELLE DE ARRANQUE
Reemplaza: 326877



18-6511
MUELLE DE ARRANQUE
Reemplaza: 312932



18-6522
MUELLE DE ARRANQUE
Reemplaza: 323653, 338534

H.P.	AÑOS	MUELLE ARRANQUE	H.P.	AÑOS	MUELLE ARRANQUE	H.P.	AÑOS	MUELLE ARRANQUE	H.P.	AÑOS	MUELLE ARRANQUE
2	1969-80	18-6511	4.5	1980-90	18-6511	10	1950-63	18-6501	18	1968-73	18-6501
3	1954-68	18-6501	5.5	1954-68	18-6501	12	1980-92	18-6522	20	1956-73,	
4 ①	1969-92	18-6511	7.5	1954-68	18-6501	12	1956-68	18-6501		85-97	18-6501
4 ②	1969-80	18-6511	9.9	1980-92	18-6522	15	1979-92	18-6522	28	1969-92	18-6501
4 ③	1981-92	18-6509	9.9	1974-78	18-6503	15	1956-68	18-6501	25	1969-05	18-6501
			10	1980-92	18-6522	15	1974-78	18-6503	30	1984-05	18-6501
① Sólo nmodelos1992 4D			③ Todos 4D						35	1976-94	18-6501
② Excepto 4D											

PACK. DE 3



18-6513
18-6513-9^④
UÑA ARRANQUE
Reemplaza: 203698

PACK. DE 2



18-6512
18-6512-9^④
UÑA ARRANQUE
Reemplaza: 330525

HP	Años	Uña	HP	Años	Uña	HP	Años	Uña
2	1971-88	18-6513	18	1957-73	18-6513	30	1984-90	18-6512
Jr/Colt	1990	18-6513	20	1981-90	18-6512	35	1976-77	18-6513
3	1957-67	18-6513	25	1969-76	18-6513	35	1978-90	18-6512
4	1978-90	18-6513	25	1977	18-6513	45	1958-59	18-6513
5.5	1957-64	18-6513	25	1978-90	18-6512	50	1958-89	18-6513
7.5	1957-76	18-6513	25C	1982-90	18-6512	60	1964-66	18-6513
10	1957-62	18-6513	30	1957-61	18-6512	75	1960-65	18-6513
						80	1966	18-6513

④ Precio por envase

Fig #	Descripción	Ref #	O.E.M. #	Cant.	Fig #	Descripción	Ref #	O.E.M. #	Cant.
1	Engranajes alojamiento	—	434030	1	46	Tornillo	—	325539	2
2	Tubo agua	—	395339	1	47	Arandela de empuje superior	—	327716	1
3	Casquillo	18-3329	302497	1	48	Cojinete empuje	—	388027	1
4	Alojamiento bomba de agua	18-3367	393632	1	49	Arandela de empuje	—	330441	1
5	Tubo, Extensión	—	326692	1	50	Engranaje	18-1288	328313	1
6	Aro tórico	18-7105	311338	2	51	Cojinete empuje	—	386186	1
7	Tornillo, bomba agua alojamiento	—	328725	6	52	engranaje empuje	18-1287	392475	1
8	Aro tórico	18-7146	554545	1	53	Desplazable	18-1290	337020	1
9	Alojamiento impulsor	18-3358	328751	1	54	Muelle	—	327070	1
10	Impulsor	18-3051	395289	1	55	Bola retención	18-2243	316506	2
11	Llave, bomba de agua	18-3295	344470	1	56	Horquilla leva	—	337019	1
12	Cojinete	—	328754	1	57	Desplazable	—	438311	1
13	Aro	18-7100	301877	1	58	Pivote	—	302504	1
14	Retén goma	18-2539	328753	1	59	Pasador, palanca de cambio	—	303049	1
15	Platina desgaste	18-3359	328753	1	60	Acoplamiento	—	390023	1
16	Junta, bomba de agua	18-0124	325537	1	61	Eje hélice	—	439143	1
17	Eje (15")	—	341635	1	62	Engranaje reverso	18-1289	327655	1
	Eje (20")	—	341636	1	63	Cojinete, engranaje reverso	—	319635	1
18	Eje retén (superior)	18-2065	332261	1	64	Retenedor platina	—	319746	1
19	Eje retén (inferior)	18-2033	321938	1	65	Aro retenedor	—	319747	1
20	Cojinete, eje	—	386473	1	66	Arandela	—	319684	1
21	Collar, alojamiento	—	322018	1	67	Cojinete	—	437288	2
22	Cojinete, Piñon	—	437288	2	68	Aro tórico	18-7108	338518	1
23	Tuerca, alojamiento	—	306422	1	69	Retén	18-7475	332584	2
24	Arandela	—	301250	1	70	Tornillo	—	319743	2
25	Cojinete	—	319785	1	71	Cojinete diabolo	—	433428	1
26	Pasador	—	320173	1	72	Retén	18-2026	321453	2
27	Conector	—	325624	1	73	Espaciador	18-4229	319890	1
28	Varilla	—	331479	1	74	Espaciador	18-4232	323943	1
29	Retén	—	325625	2	75	Pasador	18-3707	319891	1
30	Tuerca	—	331465	1	76	kit juntas alojamiento	18-3743	320785	1
31	Eje cambio	—	326361	1	77	kit bomba agua	18-3382	393639	1
32	Aro tórico	18-7180	303347	1	78	kit juntas alojamiento	18-2658	396351	1
33	Aro tórico	18-7100	301877	1					
34	Arandela	18-0189	321738	1					
35	Kit anodo	—	434029	1					
36	Arandela de cierre	—	304454	1					
37	Tornillo	—	333677	1					
38	Tornillo	—	329217	1					
39	Anodo	—	336203	1					
40	Tornillo	—	328333	4					
41	Junta tornillo drenaje	18-4248	311598	2					
42	Tornillo	18-2387	307551	2					
43	Retén	18-7475	332584	1					
44	Pasador	—	308376	1					
45	Rejilla entrada de agua	—	336202, 336206	2					

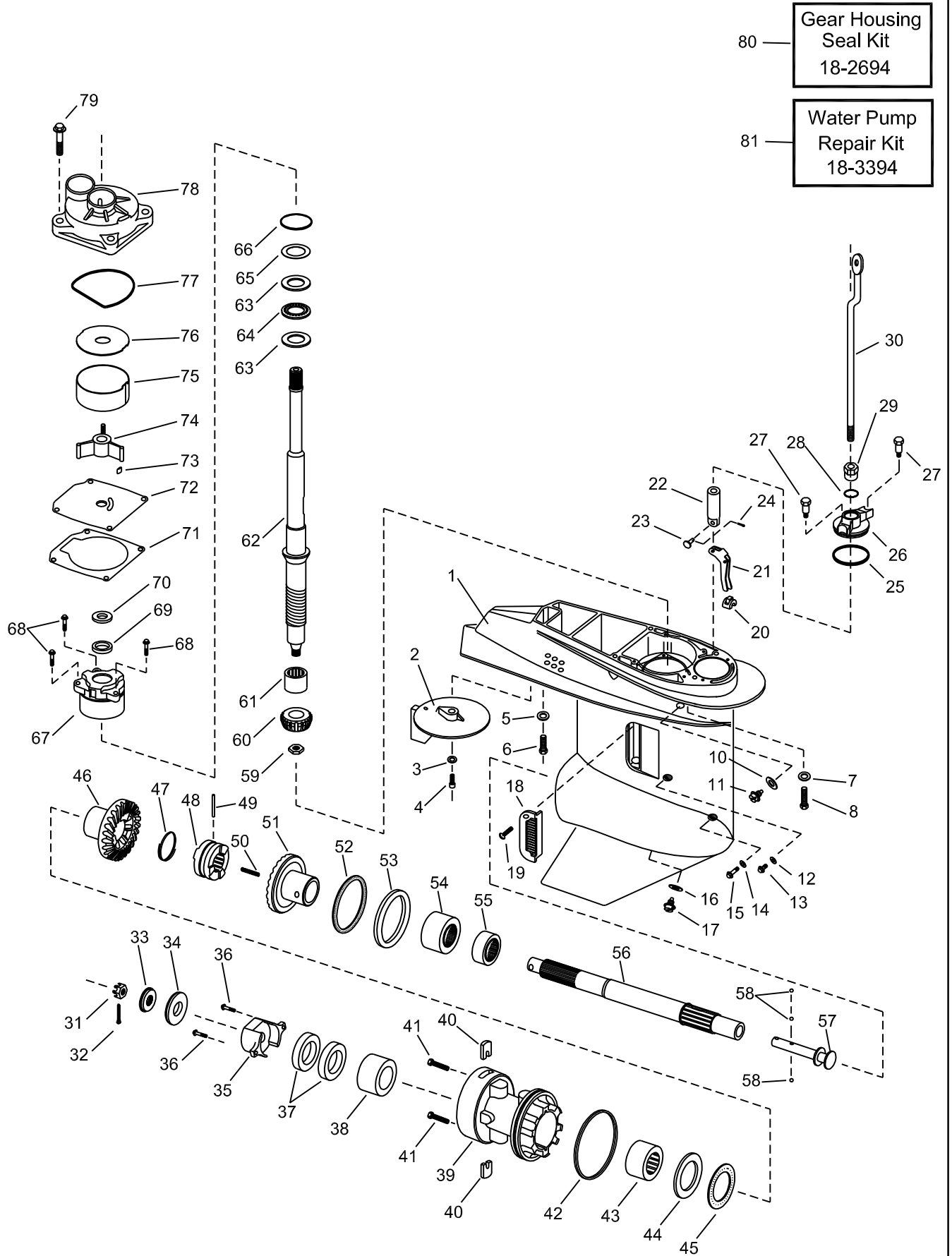

Lista completa de caja de engranajes en la página 205

Fig #	Descripción	Ref #	O.E.M. #	Cant.	Fig #	Descripción	Ref #	O.E.M. #	Cant.
1	Engranajes alojamiento	—	435275	1	47	Muelle	18-2398	320311	1
2	Anodo	—	340539	1	48	Embrague	18-2308	332491	1
3	Arandela, Anodo	—	330266	1	49	Pasador	—	320310	1
4	Tornillo, Anodo retenedor	—	330930	1	50	Muelle	—	332484	1
5	Arandela	—	330265	1	51	Set engranajes	18-2310	397627	1
6	Tornillo	—	313697	1	52	Cojinete empuje	18-1364	397538	1
7	Arandela	—	330266	4	53	Arandela empuje	18-0197	333725	1
8	Tornillo	—	305282	4	54	Cojinete	18-1351	382407	1
10	Aro tórico	18-4253-9	336982	1	55	Cojinete empuje, Engranaje avance	18-1369	432264	1
11	tornillo drenaje superior	18-1236	309243	1	56	Eje hélice	18-2288	439138	1
12	Retén	18-7475	332584	1	57	Eje	—	332503	1
13	Tornillo	—	324852	1	58	Bola retención	18-2243	316506	3
14	Aro tórico, tornillo	18-7109	317178	1	59	Tuerca piñón	—	313339	1
15	Tornillo, palanca de cambio	—	333770	1	60	Set engranajes	18-2310	397627	1
16	Junta, tornillo drenaje	18-4248	311598	1	61	Cojinete piñón	18-1356	382343	1
17	tapón llenado inferior	18-2378	318544	1	62	Transmisión (std)	—	433066	1
18	Rejilla entrada de agua	—	332494	2		Transmisión (larga)	18-1721	433067	1
19	Tornillo	—	325539	2	63	Arandela, empuje	18-0201	333771	2
20	Cuna	—	332507	1	64	Cojinete empuje, Driveshaft	18-1368	398901	1
21	Palanca	—	332492	1	65	Arandela (.003)	—	313273	AR
22	Conector	—	332508	1		Arandela (.004)	—	313274	AR
23	Pasador conector	—	302504	1		Arandela (.005)	—	313275	AR
24	Pasador	—	306376	1		Arandela (.006)	—	313276	AR
25	Aro tórico	—	338522	1		Arandela (.007)	—	313277	AR
26	Tapa	18-1729	434588	1	66	Aro tórico, Engranaje aloj.	18-7173	310327	1
27	Tornillo	—	316037	2	67	Tapa	—	435274	1
28	Aro tórico	18-7137	318372	1	68	Tornillo, Retención de transm.	—	317624	3
29	Cojinete	—	333780	1	69	Retén inferior	18-2059	321466	1
30	Barra (std.)	—	332509	1	70	Retén superior	18-2064	332205	1
	Barra larga	—	332510	1	71	Junta impulsor	18-2709	336530	1
31	Tuerca	18-3705	314503	1	72	Impulsor platina	NSS	341038	1
32	Pasador	18-3742	314502	1	73	LLave impulsor	18-3138	334897	1
33	Espaciador	18-4228	315810	1	74	Impulsor	18-3104-1	432941	1
34	Arandela, hélice	18-4230	320305	1	75	Insert	NSS	324980	1
35	Anodo, Cojinete alojamiento	—	398873	1	76	Casquillo alojamiento	18-3126	321940	1
36	Tornillo, Anodo retenedor	—	328694	2	77	Retén, goma	18-7481	324981	1
37	Retén aceite, Prop eje	18-2060	321467	2	78	Alojamiento, W/P	18-3129	438544	1
38	Cojinete aguja	18-1355	386765	1	79	Tornillo, bomba agua alojamiento	18-3369	302325	4
39	Cojinete	18-1708	432276	1	80	Kit retén alojamiento engr.	18-2694	433550	1
40	Retenedor	18-1343	332495	2	81	Kit reparación bomba agua	18-3394	433548	1
41	Tornillos	—	328744	2					
42	Aro tórico, Cojinete alojamiento	18-7172	553126	1					
43	Cojinete, Aguja	18-1354	386764	1					
44	Arandela empuje, engr.reverso	18-0196	332514	1					
45	Cojinete empuje, Engr. reverso	18-1363	397537	1					
46	Engranaje, Reverso	18-2309	332489	1					

AR Se requiere

NSS No se vende por separado

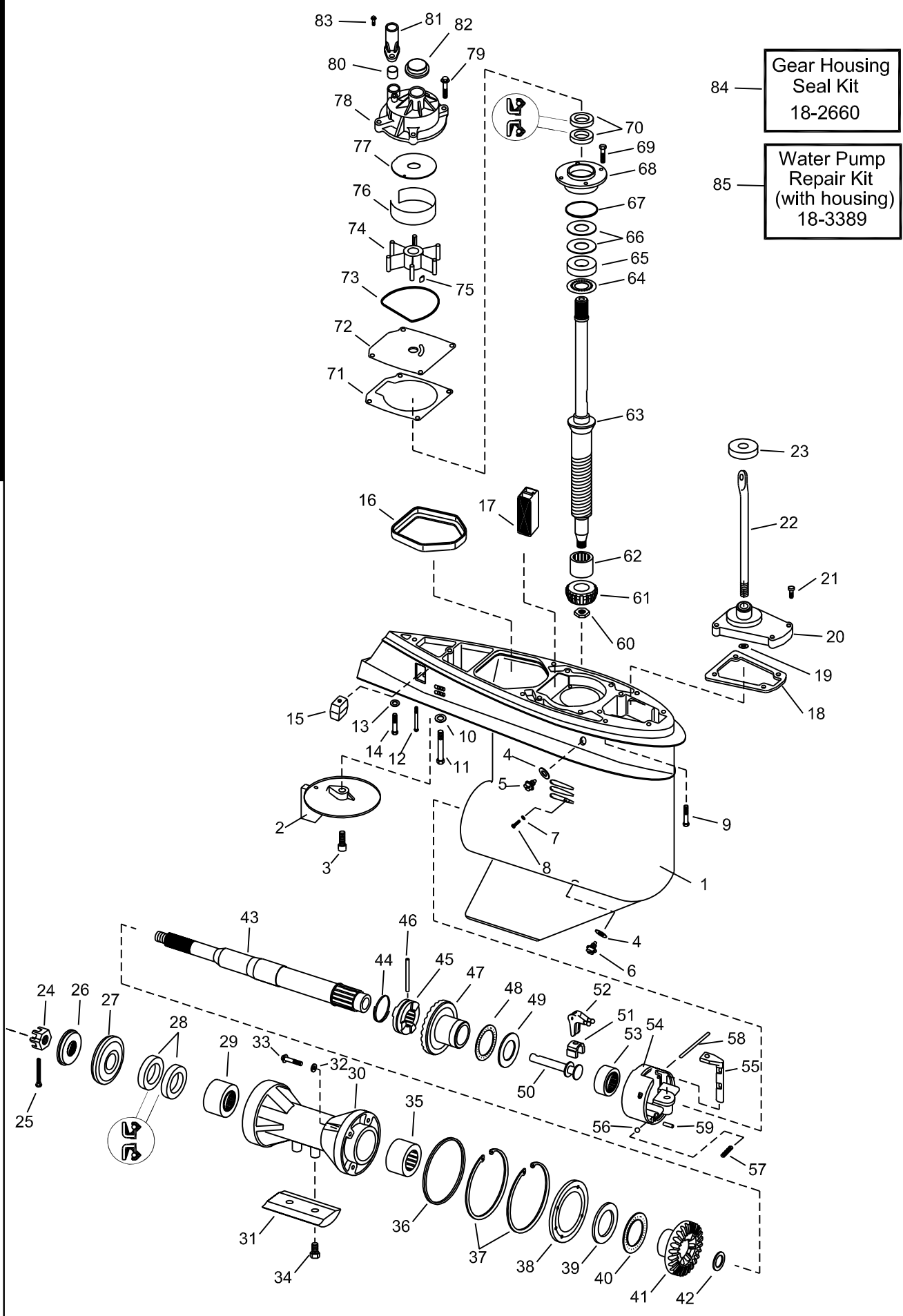

- 84 — Gear Housing Seal Kit 18-2660
- 85 — Water Pump Repair Kit (with housing) 18-3389

Lista completa de caja de engranajes en la página 207

Fig #	Descripción	Ref #	O.E.M. #	Cant.	Fig #	Descripción	Ref #	O.E.M. #	Cant.
1	Alojamiento engranajes	—	392478	1	43	Eje hélice	18-2250	439185, 439131	1
2	Trim Tab	—	318544	1					
3	Tornillo timón de deriva	—	313715	1	44	Piñones	18-2399	324369	1
4	Aro tórico	18-7145	333572	2	45	Desplazable	18-2209	318303	1
5	Tapón llenado superior	18-2387	307551	1	46	Pasador	18-1714	313448	1
6	Tornillo drenaje	18-2378	318544	1	47	Juego engranaje avante	18-2207	397338	1
7	Retén	18-7475	332584	1	48	Cojinete de empuje	18-1371	385043	1
8	Tornillo	—	324852	1	49	Arandela empuje	18-0198	324766	1
9	Tornillo	—	308843	4	50	Eje corto	—	326668	1
10	Arandela	—	306314	1	51	Acoplamiento	18-3766	334163	1
11	Tornillo largo caja engranajes	—	313697	1	52	Palanca	—	324037	1
12	Tornillo, Anodo	—	328096	1	53	Cojinete alojamiento	NSS	NSS	1
13	Arandela	—	306470	1	54	Ensamblaje alojamiento cojinete	—	391365	1
14	Tornillo corto caja de engranajes	—	306503	1	55	Varilla de cambio	—	326670	1
15	Anodo	18-6024	436745	1	56	Bola retención	—	327345	1
16	Retén, Escape	18-2537	324937	1	57	Muelle	—	911961	1
17	Rejilla entrada de agua	—	314175	1	58	Pasador	—	320145	1
18	Junta alojamiento, varilla cambio	18-2855	314082	1	59	Pasador	18-3765	331880	1
19	Aro tórico, varilla de cambio	18-7137	318372	1	60	Tuerca piñon	—	313339	1
20	Alojamiento varilla de cambio	—	388651	1	61	engranaje piñon	NSS	NSS	1
21	Tornillo alojamiento bomb.agua	18-3133	302325	4	62	Cojinete piñon	18-1356	382343	1
22	Varilla de cambio	—	327337	1	63	Eje transom	—	437376	1
23	Casquillo	18-2706	321008	1	64	Cojinete empuje	—	317230	1
24	Tuerca hélice	18-3705	314503	1	65	Arandela empuje	18-1367	385068	1
25	Pasador	18-3742	314502	1	66	Arandela (.003)	18-2232	323889	AR
26	Espaciador	18-4228	315810	1	66	Arandela (.004)	18-2233	323890	AR
27	Arandela empuje	18-4222	127084, 318841	1	66	Arandela (.005)	18-2234	317232	AR
28	Retén salida	18-8326	330137	1	67	Aro tórico cojinete alojamiento	18-7128	313754	1
28	Cojinete retén	18-2001	342787	1	68	Alojamiento eje	—	385087	1
29	Cojinete (Aft)	18-1350	379504	1	69	Tornillo	—	909386	4
30	Ensamblaje	—	434391	1	70	Retén	18-8325	342786	1
31	Anodo	—	306470	1	71	Junta bomba agua	18-2709	336530	1
32	Retén	18-7475	332584	4	72	Platina impulsor	18-3127	341038	1
33	Tornillo	18-2379	320041	4	73	Retén alojamiento bomba agua	18-7481	324981	1
34	Tornillo	—	127466	2	74	Impulsor	18-3053-1	396725	1
35	Cojinete	18-1351	382407	1	75	Chaveta	18-3138	334897	1
36	Aro tórico, alojamiento cojinete	18-7127	313446	1	76	Casquillo alojamiento	—	321940	1
37	Aros	—	313445	2	77	Platina	18-3126	324980	1
38	Platina	—	313453	1	78	Alojamiento bomba agua	18-3129	435673	1
39	Arandela empuje larga, Engranaje reverso	18-0193	313447	1	79	Tornillo alojamiento bomba agua	18-3133	302325	1
40	Cojinete empuje, engr. reverso	18-1366	382408	1	80	Casquillo	18-2703	314008	1
41	Engranaje reverso	18-2208	318304	1	81	Guía tubo de agua	—	319276	1
42	Arandela empuje corta, Engranaje reverso	—	316484	1	82	Casquillo	18-2705	342786	1
					83	Tornillo	18-3153	908158	1
					84	Kit retén alojamiento engranaje	18-2660	396349	1
					85	Kit reparación bomba de agua, Completo	18-3389	432955	1

AR Se requiere

NSS No se vende por separado

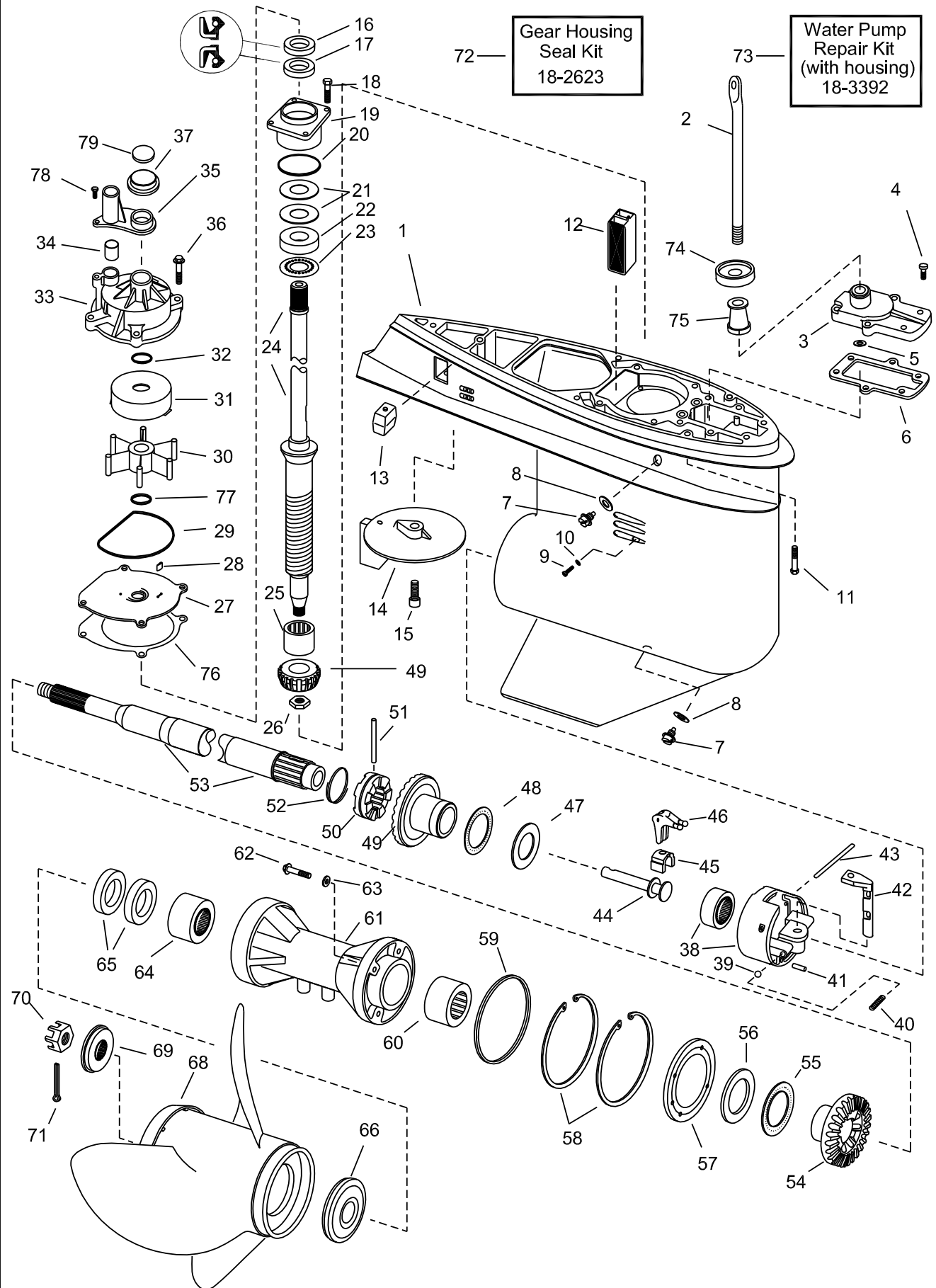

Lista completa de caja de engranajes en la página 209

Fig #	Descripción	Ref #	O.E.M. #	Cant.	Fig #	Descripción	Ref #	O.E.M. #	Cant.
1	Caja engranajes alojamiento	—	431642	1	43	Pasador	—	320145	1
2	Barra (larga)	—	332120	1	44	Eje cambio	18-3763	322941	1
	Barra (extra-larga)	—	332121	1	45	Cuna	18-3766	334163	1
3	Tapa	—	388618	1	46	Palanca	—	324037	1
4	Tornillo	18-3369	302325	6	47	Arandela empuje	18-0198	324766	1
5	Aro tórico	18-7137	318372	1	48	Arandela empuje	18-1371	385043	1
6	Junta	18-0110	324670	1	49	Set engranajes	18-2218	398035	1
7	Tornillo drenaje magnético	18-2378	318544	1	50	Embrague	18-2220	323664	1
8	Aro tórico	18-7145	333572	1	51	Pasador	18-1714	313448	1
9	Tornillo	—	324852	1	52	Muelle	18-2399	324369	1
10	Aro tórico	18-7475	332584	1	53	Eje hélice	18-2252	387818	1
11	Tornillo, caja engranajes aloj.	—	331999	5	54	Engranaje reverso	18-2219	333077	1
12	Rejilla entrada de agua	—	323466	1	55	Cojinete empuje, engr. reverso	18-1366	382408	1
13	Anodo	18-6024	393023	1	56	Arandela empuje, engr. reverso	18-0195	314731	1
14	Anodo	—	327640	1	57	Platina retenedor/Cojinete aloj.	—	314732	1
15	Tornillo	—	313715	1	58	Aros retenedores	—	313445	2
16	Retén aceite, superior	18-2061	329922	1	59	Aros tóricos cojinetes aloj	18-7127	313446	1
17	Retén aceite, inferior	18-2062	329923	1	60	Cojinete	18-1351	382407	1
18	Tornillo, caja engranajes aloj.	—	317624	4	61	Cojinete alojamiento	—	397087	1
19	Cojinete alojamiento	—	397493	1	62	Tornillo	18-2377	316563	4
20	Aro tórico cojinete alojamiento	18-7130	314728	1	63	Aro tórico	18-7475	332583	1
21	Arandela .003	18-2229	323362	AR	64	Cojinete (Aft)	18-1350	379504	1
	Arandela .004	18-2230	323361	AR	65	Retén aceite, eje hélice	18-2001	330137	2
	Arandela .005	18-2231	314745	AR	66	Arandela empuje	18-4222	318841	1
22	Arandela empuje, Piñón	18-0200	327656	1	68	Hélice	—	Various	1
23	Cojinete empuje, Piñón	18-1365	387656	1	69	Espaciador	18-4228	315810	1
24	Eje transmisión (largo)	—	394613	1	70	Tuerca	18-3705	314503	1
	Eje transmisión (x-largo)	—	394614	1	71	Pasador, Tuerca	18-3742	314502	1
25	Cojinete, Piñón	18-1357	384195	1	72	Kit retén alojamiento engranajes	18-2623	396354	1
26	Tuerca, Piñón	18-3719	314730	1	73	Kit reparación bomba agua	18-3392	395062	1
27	Platina desgaste	18-3346	330380	1					
28	Chaveta	18-3299	331107	1	74	Casquillo	18-2706	321008	1
29	Retén alojamiento impulsor	18-7963	331353	1	75	Espaciador	—	321122	1
30	Impulsor	18-3059	395864	1	76	Junta, Impulsor aloj. platina	18-2557	324701	1
31	Tapa impulsor	18-3346	330379	1	77	Aro tórico	—	302035	1
32	Aro tórico, eje transmisión	18-2769	332000	1	78	Tornillo, tapa impulsor	18-3135	306643	2
33	bomba agua alojamiento	18-3130	395040	1	79	Aro tórico	18-7158	310585	1
34	Casquillo tubo agua	18-2703	314008	1					
35	Tapa bomba	—	321159	1					
36	Tornillo impulsor alojamiento	—	328715	4					
37	Casquillo	18-2704	320943	1					
38	Cojinete alojamiento ensamblaje	—	391365	1					
39	Bola retención	—	327345	1					
40	Muelle	—	326666	1					
41	Pasador alojamiento	18-3765	331880	1					
42	Varilla retención	—	323946	1					

AR Se requiere

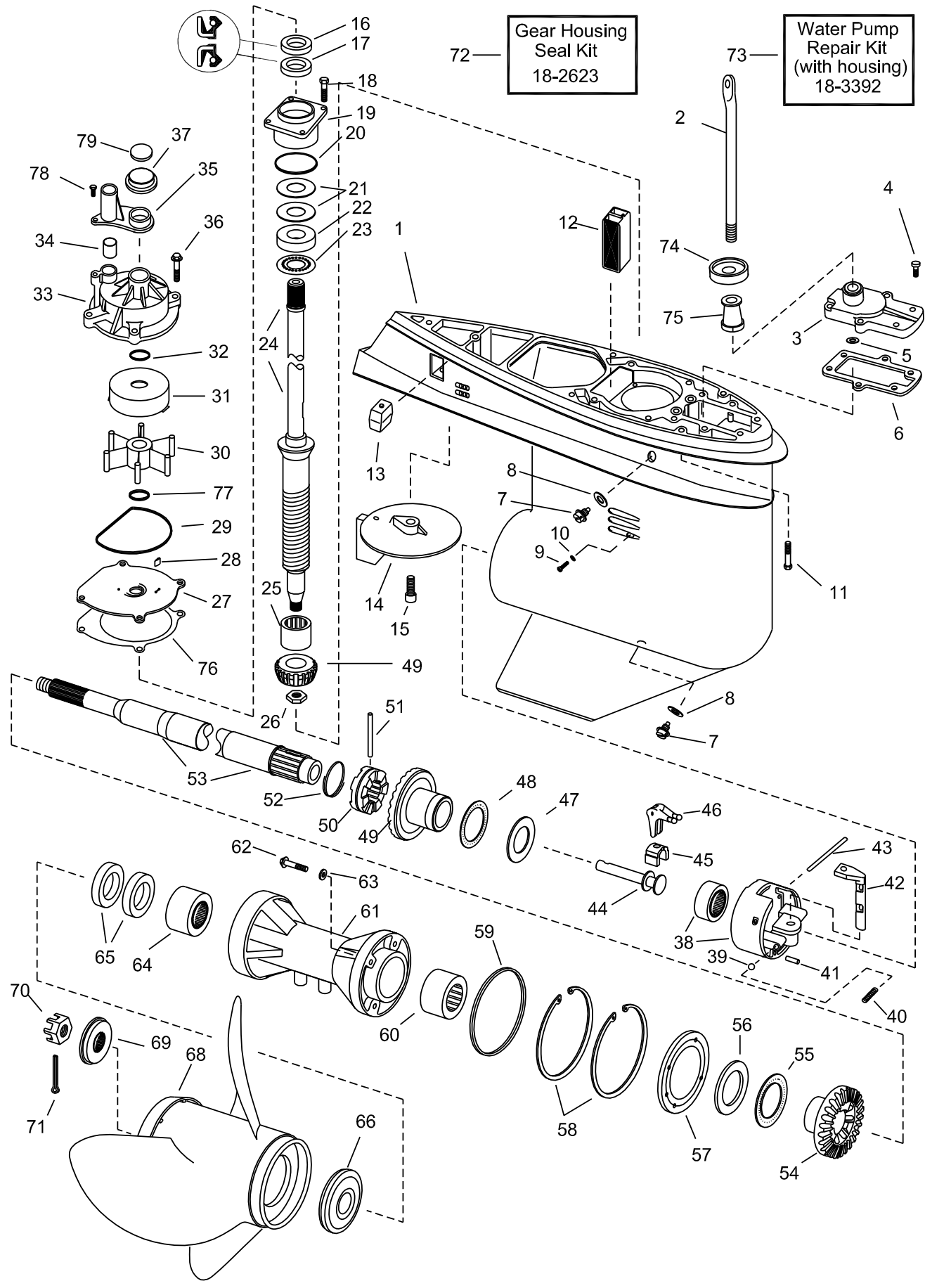

Lista completa de caja de engranajes en la página 102

Fig #	Descripción	Ref #	O.E.M. #	Cant.	Fig #	Descripción	Ref #	O.E.M. #	Cant.
1	Caja engranajes	—	438050	1	43	Pasador	—	328825	1
2	Barra (largo)	—	324407	1	44	Eje cambio	18-3763	322941	1
2	Barra (x-largo)	—	324408	1	45	Cuna	18-3766	334163	1
3	Tapa & barra	—	435482	1	46	Palanca	18-3762	322938	1
4	Tornillo tapa	18-3369	302325	6	47	Arandela empuje	18-0199	327669	1
5	Aro tórico	18-7137	318372	1	48	Cojinete empuje	18-1370	389042	1
6	Junta	18-0110	324670	1	49	Set engranajes	NSS	435020	1
7	Tornillo drenaje magnético	18-2378	318544	2	50	Embrague	18-2216	337774	1
8	Aro tórico	18-7145	333572	2	51	Pasador	18-1714	313448	1
9	Tornillo	—	324852	1	52	Muelle retenedor	18-2399	324369	1
10	Aro tórico	18-7120	307853	1	53	Eje hélice	18-2187	395209	1
11	Tornillo,caja engr. aloj.	—	320741	5	54	Engranaje reverso	NSS	910994	1
12	Rejilla entrada de agua	—	321123	1	55	Cojinete empuje, engr.reverso	18-1366	382408	1
13	Anodo	18-6024	393023	1	56	Arandela empuje, engr.reverso	18-0195	314731	1
14	Anodo	—	327640	1	57	Platina retenedora/Cojinete aloj.	—	321174	1
15	Tornillo,Trim tab	—	313715	1	58	Aros retenedores	—	321171	2
16	Retén aceite, superior	18-2061	329922	1	59	Aro tórico , Cojinete alojamiento	18-7133	305123	1
17	Retén aceite, inferior	18-2062	329923	1	60	Cojinetes	18-1351	382407	1
18	Tornillo,caja engranajes aloj.	—	316534	4	61	Cojinete alojamiento	—	397094	1
19	Cojinete alojamiento	—	438963	1	62	Tornillo retenedor	18-2377	316563	4
20	Aro tórico, Cojinete alojamiento	18-7130	314728	1	63	Aro tórico	18-7109	317178	1
21	Arandela .003	18-2229	323362	AR	64	Cojinete (Aft)	18-1158	387247	1
21	Arandela .004	18-2230	323361	AR	65	Retén aceite, eje hélice	18-2002	320862	2
21	Arandela .005	18-2231	314745	AR	66	arandela empuje	18-4223	333592	1
22	arandela empuje, Piñón	18-0200	327656	1	68	Hélice	—	various	1
23	Cojinete empuje, Piñón	18-1365	387665	1	69	Espaciador	18-4231	320570	1
24	Drive Shaf (long)	see app chart	435755	1	70	Tuerca, Hélice	18-3708-1	398042	1
24	Drive Shaft (x-long)	see app chart	435756	1	71	Pasador, tuerca Prop	18-3741	306394	1
25	Cojinete, Piñón	18-1117	387817	1	72	Kit retén engranajes alojamiento	18-2623	396353	1
26	Tuerca, piñón	18-3719	314730	1	73	Kit reparación bomba agua	18-3392	434421	1
27	Cup & Plate Assembly	18-3346	330380	1					
28	Chaveta	18-3299	331107	1	74	Casquillo	18-2706	321008	1
29	Retén, alojamiento impulsor	18-7963	331353	1	75	Espaciador	—	321122	1
30	Impulsor	18-3059	397131	1	76	Junta,Impulsor platina aloj.	18-2557	324701	1
31	Montaje Vaso & Platina	18-3346	330379	1	77	Aro tórico	18-7158	310585	1
32	Aro tórico	18-7158	310585	1	78	tornillo, tapa impulsor	18-3135	306643	2
33	Alojamiento, bomba de agua	18-3130	395040	1	79	Aro tórico	18-7158	310585	1
34	Casquillo, tubo de agua	18-2703	314008	1					
35	Tapa bomba	—	321159	1					
36	Tornillo, impulsor alojamiento	18-3136	323626	4					
37	Casquillo	18-2704	320943	1					
38	Cojinete alojamiento	—	389455	1					
39	Bola retención	18-1501	160084	1					
40	Muelle retención	18-1502	911962	1					
41	Pasador alojamiento	18-3765	331880	1					
42	Retenedor	—	323946	1					

AR Se requiere



18-4840^②
TRANSMISIÓN COMPLETA
PARTE INFERIOR
 Reemplaza: 435277
 Para: 40/48/50hp c/20" Eje (1989-92)



18-4841^②
TRANSMISIÓN COMPLETA
PARTE INFERIOR
 Reemplaza: 435276
 Para: 40/48/50hp c/15" Eje (1989-92)



18-4843^②
TRANSMISIÓN COMPLETA PARTE
INFERIOR
 Reemplaza: 435279
 Para: 40/48/50hp c/15" Eje (1993 y sup)

Pack. de 5



18-2377
18-2377-9^①
TORNILLO DE
DRENAJE
 Reemplaza: 316563

Pack. de 4



18-2379
18-2379-9^①
TORNILLO UNIDAD
INFERIOR
 Reemplaza: 320041



18-4826
TORNILLO
 Reemplaza: 331999

Pack. de 5



18-4253-9^①
18-42531-9^①
 (PACK. DE 50)
TORNILLO DRENAJE
ARO TÓRICO
 Reemplaza: 336982
 Use con 18-1236 tornillo drenaje

Pack. de 5



18-4248
18-4248-9^①
18-42481-9^①
 (PACK. DE 50)
ARANDELA
 (Plastico)
 Reemplaza: 311598
 Use con 18-2387 tornillo drenaje

Pack. de 2



18-2945
18-2945-9^①
18-29451-9^①
 (Pack. de 50)
JUNTA TORNILLO
DRENAJE
 Reemplaza: 307552



18-1236
TORNILLO DRENAJE
 Reemplaza: 309243
 Para: 40-50 HP (1989-97)
 Cobra



18-2387
18-23871-9^①
 (Pack. de 50)
TORNILLO
 Cabeza con ranura



18-4255
E-TEC TORNILLO
DRENAJE
 Reemplaza: 307551
 Cabeza allen



18-2378
18-23781-9^①
 (Pack. de 50)
TORNILLO DRENAJE
MAGNÉTICO
 Cabeza con ranura

^① Precio por pack

^② Todas las colas de las anteriores fotos deben pintarse.



18-4249
TORNILLO DRENAJE
MAGNÉTICO E-TEC
Reemplaza: 318544
Cabeza allen



18-3708-1
TUERCA
Reemplaza: 398042

Pack. de 5



TUERCA HÉLICE

REF #	O.E. #
18-3705 ^②	314503
18-3706 ^②	318971
18-3707 ^②	319891

Pack. de 10



PASADORES

REF #	O.E. #	DIMEN.
18-3735 ^②	5030087	5/32" X 1 3/8"
18-3740 ^②	302804	3/32" X 1"
18-3741 ^②	309955	1/8" X 1 3/4"
18-3742 ^②	314502	1/8" X 1 1/4"
18-3743 ^②	320785	1/8" X 3/4"
18-3744 ^②	552906	3/32" X 3/4"

③ 18-3715D 



18-3715
KIT TUERCAS
Reemplaza: 175266
— CONTIENE —

Ref #	O.E. #	Descripción
18-3708-1	398042	Tuerca hélice
18-3741	309955	Pasador
18-4231	320570	Espaciador

③ 18-3716D 



18-3716
KIT TUERCAS HÉLICE
Reemplaza: 175267
— CONTIENE —

Ref #	O.E.#	Descripción
18-3705	314503	Tuerca hélice
18-3742	314502	Pasador
18-4228	315810	Espaciador

③ 18-3717D 



18-3717
KIT TUERCAS HÉLICE
Reemplaza: 175268
— CONTIENE —

Ref #	O.E. #	Descripción
18-3707	319891	Tuerca hélice
18-3743	320785	Pasador
18-4232	323943	Espaciador



18-3753
KIT TUERCA HÉLICE
Reemplaza: 5005034
Para: 40-130 (2001 & sup)



18-3768
TUERCA
Reemplaza: 911751
Para: Cobra: 115 (1994-97),
232 (1987-90), 252 (1986), 262 (1989),
302 (1987)



18-4222
ARANDELA EMPUJE
Reemplaza: 318841, 127084



18-4223
ARANDELA EMPUJE
Reemplaza: 333592



18-4228
ESPACIADOR
Reemplaza: 315810



18-4229
ARANDELA EMPUJE
Reemplaza: 319890



18-4230
ARANDELA EMPUJE
Reemplaza: 320305



18-4231
ESPACIADOR
Reemplaza: 320570



18-4232
ESPACIADOR
Reemplaza: 323943

APLICACIONES EN LA SIGUIENTE PÁGINA

① Precio por pack ② Precio por pieza. Para pedir envasado añadir -9 a la referencia.
③ Referencias con D envasadas. Referencias normales no envasadas

JOHNSON/EVINRUDE

JOHNSON / EVINRUDE (OMC/BRP)
Sistema transmisión

HP	Año	Espaciador anterior hélice	Arandela posterior hélice	Tuerca hélice	Pasador	Kit Tuerca
9.9/15	1974-75	—	—	18-3706	18-3740	—
9.9/15	1976-99	—	—	18-3706	18-3744	—
20	1984-90	18-4229	18-4232	18-3707	18-3743	18-3717
20/30/35	1991-99	—	18-4232	18-3707	18-3743	18-3717
25 ⑥	1991	—	18-4232	18-3707	18-3743	18-3717
25 ⑦	1991	18-4232	18-4228	18-3705	18-3742	18-3716
25 ⑧	1992	—	18-4232	18-3707	18-3743	18-3717
25/30	1984-90	18-4229	18-4232	18-3707	18-3743	18-3717
35	1976-90	18-4229	18-4232	18-3707	18-3743	18-3717
40 ① ④	1984-99	18-4230	18-4228	18-3705	18-3742	18-3716
40 Comm	1996-97	18-4222	18-4228	18-3705	18-3742	18-3716
40 Comm	1998-99	—	18-4228	18-3705	18-3742	18-3716
45 Comm ②	1986-97	—	18-4228	18-3705	18-3742	18-3716
48 ①	1987-96	18-4230	18-4228	18-3705	18-3742	18-3716
50/60 TTL	1996-98	18-4222	18-4228	18-3705	18-3742	18-3716
50 ②	1971-74	18-4222	18-4228	18-3705	18-3742	18-3716
50 ① ④	1975-99	18-4230	18-4228	18-3705	18-3742	18-3716
50 EL&DT	1996-98	—	18-4228	18-3705	18-3742	18-3716
50 Comm ②	1977-79	18-4222	18-4228	18-3705	18-3742	18-3716
55	1968-69	18-4222	18-4228	18-3705	18-3742	18-3716
55 ①	1976-79	18-4230	18-4228	18-3705	18-3742	18-3716
55 Comm ②	1980-97	18-4222	18-4228	18-3705	18-3742	18-3716
55 Comm	1998-99	—	18-4228	18-3705	18-3742	18-3716
60/70 ④	1996-99	—	18-4228	18-3705	18-3742	18-3716
60	1970-71, 1986-95	18-4222	18-4228	18-3705	18-3742	18-3716
60 ①	1980-85	18-4230	18-4228	18-3705	18-3742	18-3716
65	1972-73	18-4222	18-4228	18-3705	18-3742	18-3716
65 Comm	1984-95	18-4222	18-4228	18-3705	18-3742	18-3716
65 Comm	1996-99	—	18-4228	18-3705	18-3742	18-3716
70	1974-95	18-4222	18-4228	18-3705	18-3742	18-3716
75 ②	1975-84	18-4222	18-4228	18-3705	18-3742	18-3716
75 ①	1975-85	18-4230	18-4228	18-3705	18-3742	18-3716
Formula E	1986-90	18-4230	18-4228	18-3705	18-3742	18-3716
Sprint	1986-90	18-4230	18-4228	18-3705	18-3742	18-3716
85	1969-80, 1995	18-4222	18-4228	18-3705	18-3742	18-3716
88/90	1981-95	18-4222	18-4228	18-3705	18-3742	18-3716
88	1996	—	18-4228	18-3705	18-3742	18-3716
90 ① ④	1996-99	—	18-4228	18-3705	18-3742	18-3716
90 ②	1996	—	18-4231	18-3708-1	—	—
90 V-4 ④	1997-99	—	18-4228	18-3705	18-3742	18-3716
90 V-4 ② ④	1997	18-4223	18-4231	18-3708-1	—	—
90 FSX/ FPX ④	1998-99	18-4223	18-4231	18-3708-1	—	—
100	1979-80	18-4222	18-4228	18-3705	18-3742	18-3716
100 ⑨	1988-94	18-4222	18-4228	18-3705	18-3742	18-3716
100 ⑩	1992	—	18-4231	18-3708-1	—	—
100 Comm ④	1996, 1998	—	18-4228	18-3705	18-3742	18-3716
100 Comm	1995-97, 1999	18-4223	18-4231	18-3708-1	—	—
100 Comm ③	1984-90	18-4223	18-4231	18-3708-1	18-3741	18-3715
110	1986-89	18-4222	18-4228	18-3705	18-3742	18-3716
112	1996	—	18-4228	18-3705	18-3742	18-3716
115	1973-94	18-4222	18-4228	18-3705	18-3742	18-3716
115 ① ④	1996-99	—	18-4228	18-3705	18-3742	18-3716
115 ②	1996	—	18-4231	18-3708-1	—	—
115 V-4 ④	1997-99	—	18-4228	18-3705	18-3742	18-3716
115 V-4 ② ④	1997	18-4223	18-4231	18-3708-1	—	—
115 FSX/ FPX ④	1998-99	18-4223	18-4231	18-3708-1	—	—
120 ③	1985	18-4223	18-4231	18-3708-1	18-3741	18-3715

APLICACIONES CONTINUAN EN LA SIGUIENTE PÁG.

- ① Modelos equipados con caja de engranajes pequeña.
- ② Modelos equipados con caja de engranajes grande
- ③ Modelos equipados con caja engr. V-6
- ④ Para hélice de 3 palas
- ⑤ Use 18-4222 para hélices 4 palas

- ⑥ Todos modelos excepto DR, DE & DT
- ⑦ Sólo modelos DR, DE & DT
- ⑧ Excepto modelos RSU, RSLU, RWENB, RWLENB
- ⑨ Excepto modelos 1992 WTLNE, WTXNENE
- ⑩ Modelos WTLNE, WTXNENE

- ① 1992 ES models only
- ② Except 1992 ESX models
- ③ Sólo modelos 1992 TL
- ④ Sólo modelos 1992 CX, TX

JOHNSON/EVINRUDE

HP	Año	Espaciador Anterior hélice	Arandela Posterior hélice	Tuerca Hélice	Pasador	Kit Tuerca
120	1986-94	18-4222	18-4228	18-3705	18-3742	18-3716
125 ①	1971-94	18-4222	18-4228	18-3705	18-3742	18-3716
125 ②	1992	—	18-4231	18-3708-1	—	—
125 Comm	1991	—	18-4231	18-3708-1	18-3741	18-3715
125 Comm	1992-96	18-4223	18-4231	18-3708-1	—	—
130	1995-99	18-4223	18-4231	18-3708-1	—	—
135	1973-76	18-4222	18-4228	18-3705	18-3742	18-3716
140	1977-84	18-4222	18-4228	18-3705	18-3742	18-3716
140 ③	1985	18-4223	18-4231	18-3708-1	18-3741	18-3715
140 ⑥	1986-94	18-4222	18-4228	18-3705	18-3742	18-3716
140 ③	1990	18-4223	18-4231	18-3708-1	18-3741	18-3715
140 ④	1992	—	18-4231	18-3708-1	—	—
150	1978-90	18-4223	18-4231	18-3708-1	18-3741	18-3715
150	1991-95	—	18-4231	18-3708-1	18-3741	18-3715
150 ④	1996-99	18-4223	18-4231	18-3708-1	—	—
155 Comm	1984-90	18-4223	18-4231	18-3708-1	18-3741	18-3715
155 Comm	1991-95	—	18-4231	18-3708-1	18-3741	18-3715
175	1977-90	18-4223	18-4231	18-3708-1	18-3741	18-3715
175	1992	—	18-4231	18-3708-1	—	—
175 ④	1993-99	18-4223	18-4231	18-3708-1	—	—
185	1984-85	18-4223	18-4231	18-3708-1	18-3741	18-3715
185 Comm ④	1991-95	—	18-4231	18-3708-1	18-3741	18-3715
200	1976-90	18-4223	18-4231	18-3708-1	18-3741	18-3715
200/225 ④	1991-95	—	18-4231	18-3708-1	18-3741	18-3715
200/225 ④	1996-99	18-4223	18-4231	18-3708-1	—	—
225	1986-90	18-4223	18-4231	18-3708-1	18-3741	18-3715
235	1978-85	18-4223	18-4231	18-3708-1	18-3741	18-3715
250/300	1991	18-4223 ⑤	18-4231	18-3708-1	18-3741	18-3715
250/300	1992	—	18-4231	18-3708-1	—	—
250/300 ④	1993-95	18-4223	18-4231	18-3708-1	—	—
250	1996-99	18-4223	18-4231	18-3708-1	—	—
2.6L	1984-85	18-4223	18-4231	18-3708-1	18-3741	18-3715
275	1986	18-4223	18-4231	18-3708-1	18-3741	18-3715
3.6L	1986-90	18-4223	18-4231	18-3708-1	18-3741	18-3715

OMC SEA DRIVE

V4	1982-90	18-4222	18-4228	18-3708-1	18-3742	18-3715
V6	1982-90	18-4223	18-4231	18-3708-1	18-3741	18-3715
V8	1987, 1989-90	18-4223	18-4231	—	—	—

- ① Modelos equipados con caja de engranajes pequeña
- ② Modelos equipados con caja de engranajes grande
- ③ Modelos equipados con caja engr. V-6
- ④ Para hélices de 3 palas
- ⑤ Use 18-4222 para hélices de 4-palas

- ⑥ Todos los modelos excepto DR, DE & DT
- ⑦ Sólo modelos DR, DE & DT
- ⑧ Excepto modelos RSU, RSLU, RWENB, RWLENB
- ⑨ Excepto 1992 modelos WTLNE, WTXNENE
- ⑩ Modelos WTLNE, WTXNENE

- ① Sólo modelos 1992 ES
- ② Except modelos 1992 ESX
- ③ Sólo modelos 1992 TL
- ④ Sólo modelos 1992 CX, TX

 <p>18-8304 RETÉN ACEITE Reemplaza: 321830</p>	 <p>18-0195 ARANDELA EMPUJE Engranaje delantero y posterior Reemplaza: 314731 Para: 45-60 HP - 2 Cil, 3 Cil, V-4 & V-6</p>	 <p>18-0197 ARANDELA EMPUJE Engranaje delantero Reemplaza: 333725 Para: 40-55 HP - 1989-1995</p>	 <p>18-0198 ARANDELA EMPUJE Engranaje delantero Reemplaza: 324766 Para: 3 Cil, V-4 & V-6</p>
 <p>18-0200 ARANDELA EMPUJE EJE TRANSMISIÓN Reemplaza: 327656 Para: V-4 & V-6</p>	 <p>18-0201 ARANDELA EMPUJE Eje transmisión Reemplaza: 333771 Para: 40-60 HP - 1990-1995</p>	 <p>18-1117 COJINETE Reemplaza: 387817</p>	 <p>18-1154 COJINETE A BOLAS Reemplaza: 377139</p>



**18-1158
COJINETE A RODILLOS**
Reemplaza: 387247



**18-1161
COJINETE AGUJAS**
Reemplaza: 983891



**18-1750
ALOJAMIENTO**
Reemplaza: -
Para: Cobra Drives Y V6



**18-1299
COJINETE**
Reemplaza: 433503
Para: motores V4 & V6 60°



**18-1344
COJINETE AGUJAS**
Ref. # J-1812
Para: Tapa cojinete eje 18-4807
(OE# 439476)



**18-1350
COJINETE AGUJAS**
Reemplaza: 379504



**18-1351
COJINETE AGUJAS**
Reemplaza: 382407



**18-1354
COJINETE AGUJAS**
Reemplaza: 386764



**18-1355
COJINETE AGUJAS**
Reemplaza: 386765



**18-1356
COJINETE AGUJAS
(PIÑÓN)**
Reemplaza: 382343



**18-1357
COJINETE AGUJAS
(PIÑÓN)**
Reemplaza: 384195



**18-1363
COJINETE EMPUJE**
Reemplaza: 397537



**18-1364
COJINETE EMPUJE**
Reemplaza: 397538



**18-1365
COJINETE EMPUJE**
Reemplaza: 387656



**18-1366
COJINETE EMPUJE**
Reemplaza: 382408



**18-1367
COJINETE EMPUJE**
Reemplaza: 385068



**18-1368
COJINETE EMPUJE**
Reemplaza: 398901



**18-1369
COJINETE EMPUJE**
Reemplaza: 432264



**18-1370
COJINETE DE EMPUJE**
Reemplaza: 389042



**18-1371
COJINETE DE EMPUJE**
Reemplaza: 385043

HP	Año	Cojinete Empuje	Cojinete piñón delantero	Cojinete Posterior	Cojinete Empuje	Cojinete empuje rev	Cojinete eje.hel.del	Cojinete Eje he.po.	Cojinete
25D	1989-95	18-1368	18-1356	18-1354	18-1355	18-1364	18-1363	18-1369	18-1351
35	1987	—	—	18-1354	18-1355	—	—	—	—
40	1984-88	—	—	18-1354	18-1355	—	—	—	—
40	1989-Sup	18-1368	18-1356	18-1354	18-1355	18-1364	18-1363	18-1369	18-1351
45 Comm	1985-Sup	—	18-1367	18-1356	18-1351	18-1350	18-1371	18-1366	—
48	1987-88	—	—	18-1354	18-1355	—	—	—	—
48	1989-96	18-1368	18-1356	18-1354	18-1355	18-1364	18-1363	18-1369	18-1351
50	1973-74	18-1367	18-1356	18-1351	18-1350	18-1366	18-1366	—	—
50	1975	—	—	18-1354	18-1355	—	—	—	—
50	1979-88	—	—	18-1354	18-1355	—	—	—	—
50	1989-Sup	18-1368	18-1356	18-1354	18-1355	18-1364	18-1363	18-1369	18-1351
50 ①	1995-Sup	18-1367	18-1356	18-1351	18-1350	18-1371	18-1366	—	—
55	1976-81	—	—	18-1354	18-1355	—	—	—	—
55 ②	1980-82	18-1367	18-1356	18-1351	18-1350	18-1366	18-1366	—	—
55 Comm	1983-Up	—	18-1367	18-1356	18-1351	18-1350	18-1371	18-1366	—
60 ②	1980-81	18-1367	18-1356	18-1351	18-1350	18-1366	18-1366	—	—
60	1980-85	—	—	18-1354	18-1355	—	—	—	—
60 ③	1986-87	—	—	18-1354	18-1355	—	—	—	—
60 ④	1986-97	18-1367	18-1356	18-1351	18-1350	18-1371	18-1366	—	—
65	1973	18-1367	18-1356	18-1351	18-1350	18-1371	18-1366	—	—
65 Comm	1984-97	—	18-1367	18-1356	18-1351	18-1350	18-1371	18-1366	—
70 ④	1974-97	18-1367	18-1356	18-1351	18-1350	18-1371	18-1366	—	—
70 ③	1979-85	—	—	18-1354	18-1355	—	—	—	—
75 ④	1975-88	18-1367	18-1356	18-1351	18-1350	18-1371	18-1366	—	—
75 ③	1979-87	—	—	18-1354	18-1355	—	—	—	—
85	1973-80	18-1365	18-1357	18-1351	18-1350	18-1371	18-1366	—	—
85	1991-95	18-1365	18-1357	18-1351	18-1350	18-1371	18-1366	—	—
88	1987-96	18-1365	18-1357	18-1351	18-1350	18-1371	18-1366	—	—
90	1981-97	18-1365	18-1357	18-1351	18-1350	18-1371	18-1366	—	—
100	1979-80	18-1365	18-1357	18-1351	18-1350	18-1371	18-1366	—	—
100	1990-94	18-1365	18-1357	18-1351	18-1350	18-1371	18-1366	—	—
100 Comm	1984-90	—	18-1365	18-1117	18-1351	18-1158	18-1370	18-1366	—
100 Comm ⑧	1989-90	—	18-1365	18-1357	18-1351	18-1350	18-1371	18-1366	—
100 Comm	1991-93	—	18-1365	18-1117	18-1351	—	18-1370	18-1366	—
110	1986-89	18-1365	18-1357	18-1351	18-1350	18-1371	18-1366	—	—
112	1994-95	18-1365	18-1357	18-1351	18-1350	18-1371	18-1366	—	—
115	1973-85	18-1365	18-1357	18-1351	18-1350	18-1371	18-1366	—	—
115	1990-95	18-1365	18-1357	18-1351	18-1350	18-1371	18-1366	—	—
120	1985	18-1365	18-1117	18-1351	18-1158	18-1370	18-1366	—	—
120	1986-92	18-1365	18-1357	18-1351	18-1350	18-1371	18-1366	—	—
125 Comm ⑤	1989-90	—	18-1365	18-1117	18-1351	18-1158	18-1370	18-1366	—
125 Comm ⑥	1989-90	—	18-1365	18-1357	18-1351	18-1350	18-1371	18-1366	—
125 Comm	1991-94	—	18-1365	18-1117	18-1351	—	18-1370	18-1366	—
125	1992	18-1365	18-1357	18-1351	18-1350	18-1371	18-1366	—	—
135	1973-76	18-1365	18-1357	18-1351	18-1350	18-1371	18-1366	—	—
140	1977-84	18-1365	18-1357	18-1351	18-1350	18-1371	18-1366	—	—
140	1985	18-1365	18-1117	18-1351	18-1158	18-1370	18-1366	—	—
140	1986-92	18-1365	18-1357	18-1351	18-1350	18-1371	18-1366	—	—
140 TX	1988-90	18-1365	18-1117	18-1351	18-1158	18-1370	18-1366	—	—
140 TX	1991-92	18-1365	18-1117	18-1351	—	18-1370	18-1366	—	—
150	1978-90	18-1365	18-1117	18-1351	18-1158	18-1370	18-1366	—	—
150	1991-95	18-1365	18-1117	18-1351	—	18-1370	18-1366	—	—
150 Comm	1993-95	—	18-1365	18-1117	18-1351	—	18-1370	18-1366	—
155 Comm	1984-90	—	18-1365	—	18-1351	18-1158	—	18-1366	—
155 Comm ⑤	1989-90	18-1365	18-1117	18-1351	18-1158	18-1370	18-1366	—	—
155 Comm ⑦	1989-90	18-1365	18-1117	18-1351	18-1158	18-1370	18-1366	—	—
175	1977	18-1365	18-1117	18-1351	18-1158	—	18-1366	—	—
175	1978-90	18-1365	18-1117	18-1351	18-1158	18-1370	18-1366	—	—
175	1991-97	18-1365	18-1117	18-1351	—	18-1370	18-1366	—	—
185	1984-85	18-1365	18-1117	18-1351	18-1158	18-1370	18-1366	—	—
185	1990	18-1365	18-1117	18-1351	18-1158	18-1370	18-1366	—	—
185	1992-94	18-1365	18-1117	18-1351	—	18-1370	18-1366	—	—
200	1976-77	18-1365	18-1117	18-1351	18-1158	—	18-1366	—	—
200	1978-90	18-1365	18-1117	18-1351	18-1158	18-1370	18-1366	—	—
200	1991-97	18-1365	18-1117	18-1351	—	18-1370	18-1366	—	—
200 Comm	1990-91	—	18-1365	18-1117	18-1351	18-1158	18-1370	18-1366	—
225	1986-90	18-1365	18-1117	18-1351	18-1158	18-1370	18-1366	—	—
225	1991-97	18-1365	18-1117	18-1351	—	18-1370	18-1366	—	—
235	1978-85	18-1365	18-1117	18-1351	18-1158	18-1370	18-1366	—	—

① Modelos 3 cilindros ③ Modelos 15" Transom ⑤ Modelos WTP ⑦ Sólo modelos WTA
 ② Modelos cuerda arranque ④ Modelos 20" Transom ⑥ Modelos ESX ⑧ Sólo modelos con prefijo "S"

EJES FUERABORDAS

 <p>18-1723 EJE INFERIOR Reemplaza: 346004 Para: V4 60° incluye: E100, E115, E75, E 90, J115 & J90</p>	 <p>18-2277 EJE INFERIOR Reemplaza: 335722</p>	
 <p>18-2279 EJE INFERIOR Reemplaza: 335679</p>	 <p>18-9219 EJE INFERIOR Reemplaza: 335677</p>	
 <p>18-1722 EJE TRANSMISIÓN Reemplaza: 438399 Para: 20" Modelos, 40-50HP (1997-99)</p>	 <p>18-1721 EJE TRANSMISIÓN Reemplaza: 433067 Para: 20" Modelos, 40-50(1989-92)</p>	
 <p>18-2328 EJE SUPERIOR Reemplaza: 435761</p>	 <p>18-2325 EJE SUPERIOR Reemplaza: 435760</p>	
 <p>18-2327 EJE SUPERIOR Reemplaza: 436234</p>	 <p>18-2326 EJE SUPERIOR Reemplaza: 436232</p>	
 <p>18-2330 EJE SUPERIOR (Extra Largo) Reemplaza: 436235</p>	 <p>18-1732 EJE INFERIOR Reemplaza: 338504 Para: V4 & V6 eje transmisión</p>	 <p>18-2093 RETÉN Reemplaza: 319664, 333096, 398051 Para: 20 - 35 HP(1977-95) retén para eje hélice 18-2026, eje transmisión 18-2033, cárter superior 18-8351</p>

HP	Año	Eje Inferior	Eje superior	Eje Superior (Extra Largo)	HP	Año	Eje Inferior	Eje superior	Eje (Extra Largo)
85 TTL	1991	18-2277	—	—	140 TX	1990-91	18-9219	—	—
85 TTL	1992-95	18-2277	18-2326	—	140 TL	1991-94	18-2277	18-2326	—
88	1991	18-2277	—	—	140 TX	1992-94	18-9219	—	—
88	1992-96	18-2277	18-2326	—	150	1990	18-9219	—	—
90	1991	18-2277	—	—	150	1991	18-9219	—	—
90	1992-97	18-2277	18-2326	—	150	1992-97	18-9219	18-2327	18-2330
90 ① ②	1995-96	—	18-2327	—	150 Comm	1993-95	18-9219	18-2327	18-2330
90 ② ③	1995-96	18-9219	—	18-2330	155 Comm	1990	18-2279③	—	—
90 ②	1997	18-2277	18-2326	—	155 Comm ⑤	1990	18-9219	—	—
100	1991	18-2277	—	—	155 Comm	1991	18-9219	—	—
100	1992-94	18-2277	18-2326	—	155 Comm	1992	18-9219	18-2326	—
100 Comm	1991	18-9219	—	—	175	1990	18-9219	—	—
100 Comm	1992-97	18-9219	18-2326	—	175	1991	18-9219	—	—
112	1994-96	18-2277	18-2326	—	175	1992-97	18-9219	18-2327	18-2330
115	1991	18-2277	—	—	185	1990	18-9219	—	—
115	1992-97	18-2277	18-2326	—	185	1991	18-9219	—	—
115 ① ②	1995-96	—	18-2327	—	185	1992-94	18-9219	18-2326	—
115 ② ③	1995-96	18-9219	—	18-2330	200	1990	18-9219	—	—
115 ②	1997	18-2277	18-2326	—	200	1991	18-9219	—	—
120	1991-93	18-2277	—	—	200	1992-97	18-9219	18-2326	—
120 ④	1993	18-9219	—	—	200 Comm	1990	18-9219	—	—
120 TL	1994	18-2277	18-2326	—	225	1990	18-9219	—	—
120 TX	1994	18-9219	—	—	225	1991	18-9219	—	—
125 Comm	1991-95	18-9219	18-2326	—	225	1992-97	18-9219	18-2326	—
125	1992-93	18-2277	—	—	250	1991-95	18-2279	—	—
125 ④	1993	18-9219	—	—	250	1997	18-2279	—	—
125	1994	18-2277	18-2326	—	300	1990	18-2279	—	—
130	1995-97	18-9219	18-2326	—	300	1991-95	18-2279	—	—

① 20" Modelos ② Modelos 60 grados V ③ 25" Modelos ④ F Sólo sufijo F ⑤ Sólo modelos WTP

**18-1725
EJE HÉLICE**

Reemplaza: 436834
Para: V4 60HP



**18-2187
EJE HÉLICE**

Reemplaza: 395209, 391472



**18-2250
EJE HÉLICE**

Reemplaza: 387879



**18-2251
EJE HÉLICE**

Reemplaza: 435022, 433017, 436740



**18-2252
EJE HÉLICE**

Reemplaza: 387818, 436888



**18-2355
EJE HÉLICE**

Reemplaza: 386659
Para: 35, 40, 48, 50, 55, 60, 70, 75 HP 2 & 3 cil. fuerabordas (1975-1987)



**18-2288
EJE HELICE**

Reemplaza: 397541, 439138



18-1287
ENGRANAJE Y CASQUILLO
Reemplaza: 392475
Para: 25-35HP (1975-88)



18-1291
JUEGO DE ENGRANAJES
Para: Comercial V4 caja de engranajes
- CONTIENE -

Ref #	Desc.	O.E.#
NSS	Engranaje avance	435123
NSS	Engranaje reverso	336574
18-2216	Trinquete	337774



18-1292
JUEGO DE ENGRANAJES
Para: Último modelo V-6 150-225 H.P. con engr. de reverso largo
- CONTIENE -

Ref #	Desc.	O.E.#
NSS	engranaje avance	5004216
NSS	engranaje reverso	336561



18-1293
JUEGO DE ENGRANAJES
Para: 20HP (1984-98), 25HP(1985-02),
30HP (1984-02) 35HP (1984-01)
- CONTIENE -

Ref #	Desc.	O.E.#
18-1287	Engranaje avance	392475
18-1289	Engranaje reverso	327655
18-1288	Piñón	328313
18-1290	Trinquete	337020



18-1288
ENGRANAJE PIÑÓN
Reemplaza: 328313
Para: 25-35HP (1984-96)



18-2207
JUEGO DE ENGRANAJE REVERSO
Reemplaza: 397338
Incluye: engranajes avance y piñón



18-2208
ENGRANAJE REVERSO
Reemplaza: 318304



18-2209
TRINQUETE DESLIZANTE
Reemplaza: 318303



18-2210
JUEGO DE ENGRANAJES
- CONTIENE -

Ref #	Desc.	O.E.#
18-2207	Engranaje avance	397338
18-2208	Engranaje reverso	318304
18-2209	Trinquete deslizante	318303



18-2216
TRINQUETE DESLIZANTE
Reemplaza: 337772, 337774, 334516,
336562, 910995



18-2217
JUEGO DE ENGRANAJES
- CONTIENE -

Ref #	Desc.	O.E.#
NSS	Engranaje avance	435020
NSS	Engranaje reverso	910994
18-2216	Trinquete deslizante	337772



18-2218
JUEGO DE ENGRANAJES AVANCE
Reemplaza: 434063, 989966,
985050, 436746
Incluye: Engranaje avance y piñón



18-2219
ENGRANAJE REVERSO
Reemplaza: 333077, 317838, 340490



18-2220
EMBRAGUE
Reemplaza: 323664, 320630



18-2221
JUEGO ENGRANAJE
- CONTIENE -

Ref #	Desc.	O.E.#
18-2218	Engranaje avance	434063
18-2219	Engranaje reverso	333077
18-2220	Trinquete deslizante	323664





18-2287
EMBRAGUE
Reemplaza: 319895



18-1290
EMBRAGUE
Reemplaza: 337020
Para: 25-35HP (1992-98)



18-2308
EMBRAGUE
Reemplaza: 332491



18-2309
ENGRANAJE REVERSO
Reemplaza: 332489



18-1289
ENGRANAJE REVERSO
Reemplaza: 327655
Para: 25-35 HP (1984-96)

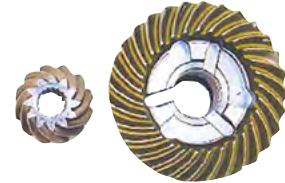

18-2310
JUEGO DE ENGRANAJES AVANCE
Reemplaza: 397627
Incluye: engranaje avance y piñón



18-2315
JUEGO DE ENGRANAJE
— CONTIENE —

Ref #	Desc.	O.E.#
18-2310	juego engranaje avance	397627
18-2309	Engranaje reverso	332489
18-2308	trinquete deslizante	332491



18-2290
JUEGO ENGRANAJE
— CONTIENE —

Ref #	Desc.	O.E.#
NSS	juego engranajes avance	435020, 434026, 983141, 391289
NSS	engranaje reverso	336561
18-2216	trinquete deslizante	337774, 334516, 336562, 910795, 337772



18-1712
RETENEDOR
Reemplaza: 980014
Para: 100, 120, 140, 165, 175, 190, 225, 235 (1968-77)



18-1500
REJILLA ADMISIÓN
Reemplaza: 337778
Para: 100, 120, 125, 140, 150, 175, 200, 225 (1993) (OMC Cobra & V-6)



18-79989
STICKS ARRASTRE
Para: Mayoría de fuerabordas de mas de 150hp con tilt/trim.



18-1343
COJINETE RETENEDOR
Reemplaza: 333957
Para: 100, 120, 125, 140, 150, 175, 200, 225, (1988-92) (Cobra)



18-4807
TAPA COJINETE EJE
Reemplaza: 439476
Para cambio cojinete use 18-1355



18-3766
BASE CAMBIO
Reemplaza: 334163
Para: V-4/V-6, Cobra, Stringer



18-3765
PASADOR ALOJAMIENTO
Reemplaza: 331880
Para: 18-3767 alojamiento



18-71102
KIT REP. CAVA CONTROL
Para: OMC 397272 + 390610

Pack. de 2



18-2243
18-2243-9^①
BOLA DE RETENCIÓN
 Reemplaza: 316506
 9.9 - 35 HP



18-2398
MUELLE TRINQUETE
 Reemplaza: 320311
 Para: 2 & 3 CIL.



18-2399
MUELLE TRINQUETE
 Reemplaza: 324369
 Para: V-4 & V-6

① Precio por pack

TODOS LOS ENGRANAJES MARCHA AVANTE INCLUYEN PIÑONES

HP	Año	Modelo	Eje Hélice	Juego Engranajes	Engranaje empuje	Engranaje reverso	Embrague
20	1985-95	TODOS		18-1293	18-1287 ⑥	18-1289	18-1290
25	1985-95	TODOS		18-1293	18-1287 ⑥	18-1289	18-1290
25D	1989-95	TODOS	18-2288	18-2315	18-2310	18-2309	18-2308
30	1984-96	TODOS		18-1293	18-1287 ⑥	18-1289	18-1290
35	1984-94	TODOS ⑥		18-1293	18-1287 ⑥	18-1289	18-1290
35	1987	AE, AR, AT	—	—	—	—	18-2287
40	1984-88	TODOS	—	18-2289	—	—	18-2287
40	1989-97	TODOS	18-2288	18-2315	18-2310	18-2309	18-2308
48	1987-88	TODOS	—	—	—	—	18-2287
48	1989-96	TODOS	18-2288	18-2315	18-2310	18-2309	18-2308
50	1975	TODOS	—	—	—	—	18-2287
50	1979-88	TODOS	—	18-2289	—	—	18-2287
50	1989-97	2 Cil.	18-2288	18-2315	18-2310	18-2309	18-2308
50	1997	3 Cil.	18-2250	—	18-2207	18-2208	18-2209
55	1976-78	TODOS	—	—	—	—	18-2287
60	1980-85	Arranque eléctrico	—	18-2289	—	—	18-2287
60	1986-87	⑥	18-2250	18-2210	18-2207	18-2208	18-2209
60 ⑥	1986-87	3 Cil.	—	—	—	—	18-2287
60	1988-97	TODOS	18-2250	18-2210	18-2207	18-2208	18-2209
65	1984	TODOS	18-2250	18-2210	18-2207	18-2208	18-2209
65	1987	TODOS	18-2250	18-2210	18-2207	18-2208	18-2209
65	1990-91	TODOS	18-2250	18-2210	18-2207	18-2208	18-2209
65 COMM	1985-97	TODOS	18-2250	18-2210	18-2207	18-2208	18-2209
65 COMM Remote	1992-95	TODOS	18-2250	18-2210	18-2207	18-2208	18-2209
65 COMM Rope	1992-95	TODOS	18-2250	18-2210	18-2207	18-2208	18-2209
70	1975	①	N/D	18-2210	18-2207	18-2208	18-2209
70	1976	TODOS	N/D	18-2210	18-2207	18-2208	18-2209
70	1977-85	⑥	18-2250	18-2210	18-2207	18-2208	18-2209
70 ⑥	1979-85	TODOS	—	—	—	—	18-2287
70	1986-97	TODOS	18-2250	18-2210	18-2207	18-2208	18-2209
70TTL	1992-95	TODOS	18-2250	18-2210	18-2207	18-2208	18-2209
75 ⑥	1975-87	TODOS	—	—	—	—	18-2287
75	1976	⑥	N/D	18-2210	18-2207	18-2208	18-2209
75	1977	⑥	18-2250	18-2210	18-2207	18-2208	18-2209
75	1978-80	⑥	18-2250	18-2210	18-2207	18-2208	18-2209
75	1982-87	⑥	18-2250	18-2210	18-2207	18-2208	18-2209
75	2000-01	FPX & FX	18-2251	18-1291	—	—	18-2216
85	1973-77	TODOS	—	—	—	18-2219	—
85	1978-80	TODOS	18-2252	18-2221	18-2218	18-2219	18-2220
85	1991-95	TODOS	18-2252	18-2221	18-2218	18-2219	18-2220
88	1987-96	TODOS	18-2252	18-2221	18-2218	18-2219	18-2220
90	1981-98 ②	TODOS	18-2252	18-2221	18-2218	18-2219	18-2220
90	1995-01	25" Transoms	18-2251	18-1291	—	—	18-2216
90	1999	TODOS	18-1725	18-2221	18-2218	18-2219	18-2220
100	1979-80, 90-95	TODOS	18-2252	18-2221	18-2218	18-2219	18-2220
100 COMM	1984-90	TODOS	18-2187	—	—	—	18-2216
100 COMM	1989-90, 1998	③	18-2252	18-2221	18-2218	18-2219	18-2220
100 COMM	1993-01	TODOS	18-2251	18-1291	—	—	18-2216
105 JET	1992	TODOS	18-2251	18-2217	—	—	18-2216
105	1997-99	TODOS	18-2251	18-1291	—	—	18-2216
105 COMM	2000-01	TODOS	18-2251	18-1291	—	—	18-2216
110	1986-89	TODOS	18-2252	18-2221	18-2218	18-2219	18-2220
112	1994-96	TODOS	18-2252	18-2221	18-2218	18-2219	18-2220
115	1973-76	TODOS	—	—	—	18-2219	—
115	1977	TODOS	18-2252	—	—	18-2219	18-2220
115	1978-85, 1990-98	TODOS	18-2252	18-2221	18-2218	18-2219	18-2220
115	1995-01	25" Transoms	18-2251	18-1291	—	—	18-2216
115	1999	20" 60 Grados V4	18-2252	18-2221	18-2218	18-2219	18-2216
115	1999	25" 60 Grados V4	18-2251	—	—	—	18-2216
120	1985	TODOS	—	—	—	—	18-2216
120	1986-92	TODOS	18-2252	18-2221	18-2218	18-2219	18-2220
120	1993-94	TL & TX ⑦	18-2252	18-2221	18-2218	18-2219	18-2220
120	1993-94	TX ⑧	18-2251	18-1291	—	—	18-2216
125 COMM	1989-90	④	18-2252	18-2221	18-2218	18-2219	18-2220

① Modelos sólo con suf. "E"

② Modelos sólo con "WTP"

③ Modelos sólo con pref. "S"

④ Sólo Modelos "ESX"

⑤ Todos los modelos excepto "ESX"

⑥ 20" Sólo Transom

⑦ Todos los modelos excepto 140TX

⑧ 15" Modelos

⑨ 1993 Modelos "ESX" sólo con sufijo "F"

⑩ Excepto 1999 modelos "FCX"

⑪ Excepto 1998 modelos "FSX"

⑫ Modelos sólo con sufijo "F"

⑬ Modelos sólo con sufijo "S"

⑭ Para engranajes reversos con 6 enganches

⑮ Excepto modelos AE, AR & AT

⑯ Piñón 18-1288 se vende por separado

TODOS LOS ENGRANAJES MARCHA AVANTE INCLUYEN PIÑONES

HP	Año	Modelo	Eje hélice	Juego Engranajes	Engranaje Empuje	Engranaje Reverso	Embrague
125 COMM	1989-90	⑤	18-2187	—	—	—	18-2216
125 COMM	1992-94, 1996	⑤	18-2251	—	—	—	18-2216
125	1991	②	18-2251	—	—	—	18-2216
125	1991-95	④ ⑨	18-2252	18-2221	18-2218	18-2219	18-2220
125	1993-95	⑥	18-2251	18-1291	—	—	18-2216
125	1996-98	TODOS	18-2251	18-1291	—	—	18-2216
130	1995-01	TL & TX & 25"	18-2251	18-1291	—	—	18-2216
135	2001	TODOS	18-2251	18-1291	—	—	18-2216
140	1977	TODOS	18-2252	—	—	—	18-2220
140	1978-84, 1986-87	TODOS	18-2252	18-2221	18-2218	18-2219	18-2220
140	1985	TODOS	18-2187	—	—	—	18-2216
140	1988-94	⑦	18-2252	18-2221	18-2218	18-2219	18-2220
140	1988-90	TX	18-2187	—	—	—	18-2216
140	1993-94	TX ⑥	18-2251	18-1291	N/D	N/D	18-2216
150	1978-79	TODOS	—	—	—	—	18-2216 ⑩
150	1980-87	CHECK O.E.	18-2187	18-2217	—	—	18-2216
150	1988-89,90	TODOS	18-2187	18-2217	—	—	18-2216
150	1991-99 ①	TODOS	18-2251	18-2290	—	—	18-2216
150	2004	TODOS	18-2251	18-1292	N/D	N/D	18-2216
150 COMM	1993-96	TODOS	18-2251	18-2290	—	—	18-2216
155 COMM	1984-88	TODOS	18-2187	—	—	—	18-2216
155 COMM WTP	1986-88	TODOS	18-2187	—	—	—	18-2216
155 COMM WTL & WTX	1989-90	TODOS	18-2187	—	—	—	18-2216
155 COMM	1989-90	②	18-2187	18-2217	—	—	18-2216
155 COMM	1991-92	TODOS	18-2251	18-2290	—	—	18-2216
175	1977	TODOS	—	N/D	N/D	N/D	18-2220
175	1978-83	TODOS	—	—	—	—	18-2216
175	1985-90	TODOS	18-2187	18-2217	—	—	18-2216
175/185	1991-99 ①	TODOS	18-2251	18-2290	—	—	18-2216
185	1984-85	TODOS	18-2187	18-2217	—	—	18-2216
200	1979-86	TODOS	—	18-2217	—	—	18-2216
200	1988-90	TODOS	18-2187	18-2217	—	—	18-2216
200	1991-99	TODOS	18-2251	18-2290	—	—	18-2216
200	2002-03	TODOS	18-2251	18-1292	N/D	N/D	18-2216
220	1987	TODOS	18-2187	18-2217	—	—	18-2216
225	1986-87	TODOS	—	18-2217	—	—	18-2216
225	1988-89	TODOS	18-2187	18-2217	—	—	18-2216
225	1991-99	TODOS	18-2251	18-2290	—	—	18-2216
225	2002-04	TODOS	18-2251	18-1292	N/D	N/D	18-2216
235	1979-85	TODOS	—	18-2217	—	—	18-2216
250	1991-99	TODOS	18-2251	—	—	—	18-2216
250	2002-03	TODOS	18-2251	18-1292	N/D	N/D	18-2216
275	1985-88	TODOS	18-2251	—	—	—	18-2216
3.6L	1985-87	TODOS	18-2251	—	—	—	18-2216
300	1988-95	TODOS	18-2251	—	—	—	18-2216

- ② Modelos sólo con "WTP"
- ③ Modelos sólo con prefijo "S"
- ④ Sólo modelos "ESX"
- ⑤ Todos modelos exc. "ESX"
- ⑥ 20" sólo Transom
- ⑦ Todos modelos excepto 140TX
- ⑧ 15" Modelos
- ⑨ 1993 Modelos "ESX" sólo suf. "F"
- ⑩ Excepto 1999 modelos "FCX"
- ⑪ Excepto 1998 modelos "FSX"
- ⑫ Modelos sólo con suf. "F"
- ⑬ Modelos sólo con suf. "S"
- ⑭ Para engranajes reverso con 6 enganches
- ⑮ Excepto modelos AE, AR & AT
- ⑯ Piñón 18-1288 se vende por separado

EJES Y ENGRANAJES

HP	Año	Modelo	Eje hélice	Juego engranajes	Engranaje	Engranaje reverso	Embrague
1.6	1990 ①	TODOS	18-2252	18-2221	18-2218	18-2219	18-2220
2	1990 ②	TODOS	18-2187	—	—	—	18-2216
2	1990 ①	TODOS	18-2187	—	—	—	18-2216
3	1990 ①	TODOS	18-2187	18-2217	—	—	18-2216
3	1990	TODOS	18-2187	18-2217	—	—	18-2216
4	1990	TODOS	18-2187	—	—	—	18-2216
1.6	1989	TODOS	18-2252	18-2221	18-2218	18-2219	18-2220
2	1989	TODOS	18-2187	—	—	—	18-2216
3	1989	TODOS	18-2187	18-2217	—	—	18-2216
4	1989	TODOS	18-2187	—	—	—	18-2216
1.6	1988	TODOS	18-2252	18-2221	18-2218	18-2219	18-2220
2	1988	TODOS	18-2187	—	—	—	18-2216
3	1988	TODOS	18-2187	18-2217	—	—	18-2216
1.6	1987	TODOS	18-2252	18-2221	18-2218	18-2219	18-2220
1.8	1987	TODOS	18-2252	18-2221	18-2218	18-2219	18-2220
2.7	1987	TODOS	18-2187	18-2217	—	—	18-2216
3.6	1987	TODOS	18-2187	—	—	—	18-2216
1.6	1986	TODOS	18-2252	18-2221	18-2218	18-2219	18-2220
2.6	1986	TODOS	18-2187	18-2217	—	—	18-2216
1.6 V-4	1985 ③	TODOS	18-2252	18-2221	18-2218	18-2219	18-2220
2.6 V-6	1985 ④	TODOS	18-2187	—	—	—	18-2216
2.5/2.6	1985 ③	TODOS	18-2187	—	—	—	18-2216
1.6 V-4	1984 ③	TODOS	18-2252	18-2221	18-2218	18-2219	18-2220
2.6 V-6	1984 ④	TODOS	18-2187	—	—	—	18-2216
2.5/2.6	1984 ③	TODOS	18-2187	—	—	—	18-2216
1.6	1983	TODOS	18-2252	18-2221	18-2218	18-2219	18-2220
2.6	1983	TODOS	N/D	—	—	—	18-2216
2.5/2.6	1982	TODOS	—	—	—	—	18-2216

- ① Sólo modelos con suf. "E"
- ② Sólo modelos con "WTP"
- ③ Sólo modelos con prefijo "S"
- ④ Sólo modelos "ESX"

Sistema transmisión
JOHNSON / EVINRUDE (OMC/BRP)



18-6526
CABLE ACELERADOR (38")
 Reemplaza: 397004
 Para: modelos 6 & 8 HP desde 1968 - 1990

APLICACIÓN CABLE ACELERADOR			
HP	AÑO INICIO	AÑO FINAL	CABLE ACELERADOR
6	1985	1990	18-6526
8	1985	1990	18-6526
14	1988	1989	18-6526

ARANDELAS

	Ref #	Desc.	O.E. #	D.I.	Ref #	Desc.	O.E. #	D.I.
	18-2224 ^③	.003 Arandela	320166	1.58	18-2230	.004 Arandela	323361	1.24
	18-2225 ^③	.004 Arandela	320167	1.56	18-2231	.005 Arandela	314745	1.24
	18-2226 ^③	.005 Arandela	320168	1.53	18-2232	.003 Arandela	323889	1.22
	18-2227 ^③	.006 Arandela	320169	1.53	18-2233	.004 Arandela	323890	1.22
	18-2228	.007 Arandela	320170	1.53	18-2234 ^{① ③}	.005 Arandela	317232	.22
	18-2229 ^{① ③}	.003 Arandela	323362	1.24				

HP	Año	0.003 Arandela	0.004 Arandela	0.005 Arandela	0.006 Arandela	0.007 Arandela
60	1980-1987	18-2224	18-2225	18-2226	18-2227	18-2228
60	1988-95	18-2232	18-2233	18-2234	—	—
60SST	1989-1990	18-2224	18-2225	18-2226	18-2227	18-2228
60TTL	1992	18-2232	18-2233	18-2234	—	—
65C	1984-91,93-95	18-2232	18-2233	18-2234	—	—
65C	1992	18-2232	18-2233	18-2234	—	—
70	1975-76	18-2232	18-2233	18-2234	—	—
70	1977-85	18-2224	18-2225	18-2226	18-2227	18-2228
70	1986-95	18-2232	18-2233	18-2234	—	—
70TTL	1992	18-2232	18-2233	18-2234	—	—
75	1975-1988	18-2224	18-2225	18-2226	18-2227	18-2228
85	1975-79	18-2229	18-2230	18-2231	—	—
85	1980,91	18-2229	18-2230	18-2231	—	—
85TTL	1992-95	18-2229	18-2230	18-2231	—	—
88	1987-95	18-2229	18-2230	18-2231	—	—
90	1981-95	18-2229	18-2230	18-2231	—	—
100	1979	18-2229	18-2230	18-2231	—	—
100	1980,90-95	18-2229	18-2230	18-2231	—	—
100C	1984-87,89-95	18-2229	18-2230	18-2231	—	—
100PLY	1989	18-2229	18-2230	18-2231	—	—
105JET	1992-93	18-2229	18-2230	18-2231	—	—
110	1986-89	18-2229	18-2230	18-2231	—	—
115	1980-85,90-95	18-2229	18-2230	18-2231	—	—
115	1975-79	18-2229	18-2230	18-2231	—	—
120	1985-95	18-2229	18-2230	18-2231	—	—
125, 125C	1989-95	18-2229	18-2230	18-2231	—	—
125ESX	1989-90	18-2229	18-2230	18-2231	—	—

HP	Año	0.003 Arandela	0.004 Arandela	0.005 Arandela	0.006 Arandela	0.007 Arandela
125WTPL	1990	18-2229	18-2230	18-2231	—	—
135	1975-76	18-2229	18-2230	18-2231	—	—
140	1977-79	18-2229	18-2230	18-2231	—	—
140	1980-95	18-2229	18-2230	18-2231	—	—
150	1979-95	18-2229	18-2230	18-2231	—	—
150C	1986-91,95	18-2229	18-2230	18-2231	—	—
155C	1984-87,89-95	18-2229	18-2230	18-2231	—	—
175	1977	18-2229	18-2230	18-2231	—	—
175	1978-88,90-95	18-2229	18-2230	18-2231	—	—
185	1984-85,90-95	18-2229	18-2230	18-2231	—	—
200	1976-77	18-2229	18-2230	18-2231	—	—
200	1978-83,86-95	18-2229	18-2230	18-2231	—	—
200C	1990	18-2229	18-2230	18-2231	—	—
225	1986-93	18-2229	18-2230	18-2231	—	—
235	1978-85	18-2229	18-2230	18-2231	—	—
1600cc	1988	18-2229	18-2230	18-2231	—	—
2500cc	1988	18-2229	18-2230	18-2231	—	—

① Envase estándar 2 ② Incluye 1 cada uno 18-2229, 18-2230 & 18-2231
 ③ Precio por pieza. Para pedir envasado añadir -9 a la referencia

ZINC es sólo para aplicaciones en agua salada.
MAGNESIO es sólo para aplicaciones en agua dulce.
ALUMINIO es tanto para agua dulce como para agua salada.

 <p>025757 Zinc 603125 Alu. ÁNODO Reemplaza: 433580 Para: 60-225 (1991-93)</p>	 <p>009322 Zinc 603123 Alu. ÁNODO Reemplaza: 173029, 123009, 327606 (1981-91) 9.9-115 HP</p>	 <p>025759 Zinc ÁNODO Reemplaza: 434029</p>
 <p>025339 Zinc 603154 Alu. ÁNODO Reemplaza: 393023, 436745 (1982-87) 60-300 HP Para uso con caja engranajes</p>	 <p>009317 Zinc 603132 Alu. ÁNODO Reemplaza: 433458, 398331 (1987-92) 60-300HP</p>	 <p>009319 Zinc 603124 Alu. ÁNODO Reemplaza: 392462 Para escape alojamiento, 2 & 3 Cil. (1984-99)</p>
 <p>025756 Zinc 603127 Alu. ÁNODO Reemplaza: 431708, 397111 (1988-90) 45-300 HP</p>	 <p>009368 Zinc ÁNODO Reemplaza: 976669 (1969-89) Kit para V4 & V6</p>	 <p>009318 Zinc 603153 Alu. ANODO Reemplaza: 392123 (1982-98) 40-300 HP</p>

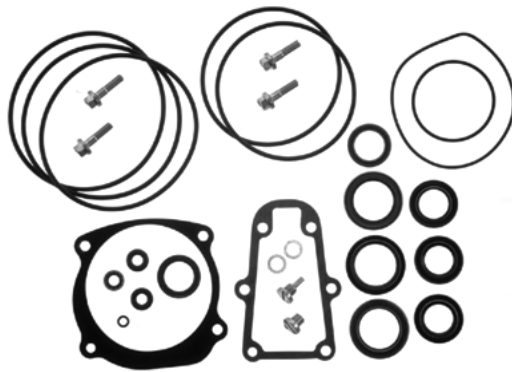

18-2623
KIT RETENES UNIDAD INFERIOR
Reemplaza: 439141

-- CONTIENE --

Ref #	Desc.	O.E. #	Cant.
18-0110	Junta	314082	1
18-2001	Retén	330137	2
18-2002	Retén	320862	2
18-2026	Retén	321453	2
18-2061	Retén	329922	1
18-2062	Retén	329923	1
18-2377	Tornillo	316563	4
18-2378	Tornillo drenaje magnético	318544	1
18-2536	Aro tórico	315788	1
18-2557	Junta impulsor	338484	1
18-4248	Arandela	311598	2
18-7109	Aro tórico	317178	1
18-7120	Aro tórico	307853	1
18-7127	Aro tórico	313446	1
18-7130	Aro tórico	314728	1
18-7133	Aro tórico	305123	2
18-7137	Aro tórico	318372	2
18-7142	Aro tórico	322119	1
18-7144	Aro tórico	333572	3
18-7145	Aro tórico	332584	1
18-7475	Arandela	328743	4
18-8300	Retén	341280	1
18-8301	Retén	341281	1



18-2656
KIT DE RETENES UNIDAD INFERIOR
Reemplaza: 396350

-- CONTIENE --

Ref #	Desc.	O.E. #	Cant.
18-2025	Retén aceite	318971	1
18-2028	retén aceite	321480	2
18-2029	Retén aceite	321481	2
18-4248	Arandela	311598	2
18-7100	Aro tórico	301877	1
18-7104	Aro tórico	308627	1
18-7120	Aro tórico	307853, 322598	1
18-7139	Aro tórico	319085	1
18-7145	Aro tórico	333572	2

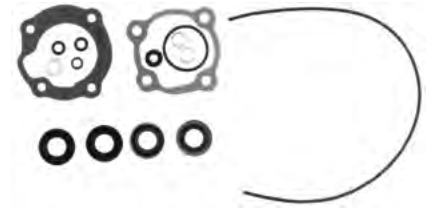

18-2657
KIT RETENES UNIDAD INFERIOR
Reemplaza: 396352

-- CONTIENE --

Ref #	Desc.	O.E. #	Cant.
18-0882	Junta	304764	1
18-0108	Junta inferior caja engranajes	324449	1
18-3360	Junta alojamiento impulsor	329390	1
18-7411	Aro tórico	—	1
18-2027	Retén aceite	321459	2
18-2031	Retén aceite	321787	1
18-2063	Retén aceite	330327	1
18-4248	Arandela	311598	2
18-7100	Aro tórico	301877	1
18-7145	Aro tónico	333572	2
18-7475	Aro Quad	332583	—



18-2658
KIT RETÉN UNIDAD INFERIOR
Reemplaza: 396351

-- CONTIENE --

Ref #	Desc.	O.E. #	Cant.
18-0124	Junta impulsor platina	325537	1
18-2026	Retén aceite	321453	2
18-2033	Retén aceite	321928	2
18-2065	Retén aceite	332261	1
18-2539	Retén goma	328753	1
18-4248	Arandela	311598	2
18-7100	Aro tórico	301877	1
18-7105	Aro tórico	311338	2
18-7108	Aro tórico	313893	1
18-7109	Aro tórico	317178	3
18-7145	Aro tórico	333572	2
18-7146	Aro tórico	554545	1
18-7180	Aro tórico	303347	1
18-2030	Retén aceite	321786	1
18-2027	Retén aceite	321459	1



18-2659
KIT RETÉN UNIDAD INFERIOR
Reemplaza: 396355

-- CONTIENE --

Ref #	Desc.	O.E. #	Cant.
18-0969	Junta impulsor alojamiento	319586	1
18-2059	Retén aceite	321466	1
18-2060	Retén aceite	321467	2
18-2064	Retén aceite	332205	1
18-2532	Retén	305762	1
18-2537	Retén goma	324937	1
18-2855	Junta tapa	314082	1
18-4248	Arandela	311598	2
18-7115	Aro tórico	302588	1
18-7120	Aro tórico	307853	1
18-7137	Aro tórico	318372	1
18-7140	Aro tórico	320303	1
18-7145	Aro tórico	333572	2
18-7475	Aro quad	332584	3

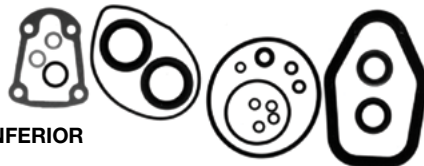

18-2660
KIT RETÉN UNIDAD INFERIOR
Reemplaza: 396349

-- CONTIENE --

Ref #	Desc.	O.E. #	Cant.
18-2059	Retén aceite	321466	1
18-2064	Retén aceite	332205	1
18-2537	Retén goma	324937	1
18-2855	Junta tapa	314082	1
18-4248	Arandela	311598	2
18-7120	Aro tórico	307853	1
18-7127	Aro tórico	313446	1
18-7128	Aro tórico	313754	1
18-7137	Aro tórico	318372	1
18-7145	Aro tórico	333572	2
18-7475	Aro quad	332584	4
18-7174	Aro tórico	910582, 326649	1
18-2001	Retén aceite	330137	2

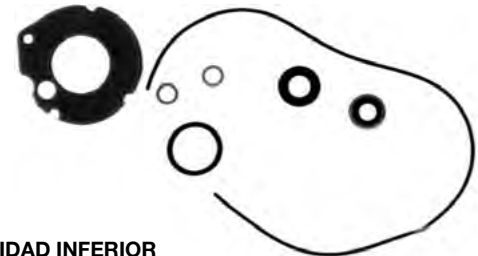

18-2679
KIT RETÉN UNIDAD INFERIOR

-- CONTIENE --

Ref #	Desc.	O.E. #	Cant.
18-2022	Retén aceite	303345	1
18-2035	Retén aceite	327031	1
18-2891	Junta alojamiento cojinete	303339	1
18-4248	Arandela	311598	2
18-7100	Aro tórico	301877	1
18-7117	Aro tórico	303360	1
18-7120	Aro tórico	307853	1
18-2534	Retén	309044	1

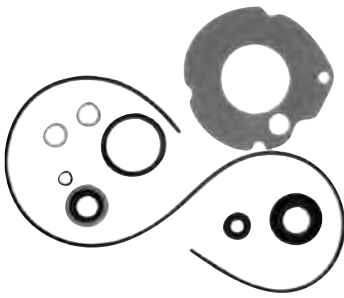

18-2680
KIT RETENES UNIDAD INFERIOR

- CONTIENE -

Ref #	Desc.	O.E. #	Cant.
18-2023	Retén aceite	313282	1
18-2035	Retén aceite	327031	1
18-2891	Junta alojamiento cojinete	303339	1
18-4248	Arandela	311598	2
18-7100	Aro tórico	301877	1
18-7117	Aro tórico	303360	1
18-7120	Aro tórico	307853	1
18-2534	Retén	309044	1



18-2681
KIT RETENES UNIDAD INFERIOR

- CONTIENE -

Ref #	Desc.	O.E. #	Cant.
18-2023	Retén aceite	313282	1
18-2024	Retén aceite	314167	1
18-2891	Junta alojamiento cojinete	303339	1
18-4248	Arandela	311598	2
18-7100	Aro tórico	301877	1
18-7117	Aro tórico	303360	1
18-7120	Aro tórico	307853	1
18-2534	Retén	309044	1

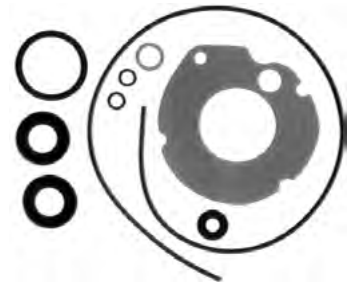

18-2682
KIT RETENES UNIDAD INFERIOR

- CONTIENE -

Ref #	Desc.	O.E. #	Cant.
18-2022	Retén aceite	303345	2
18-2891	Junta alojamiento cojinete	303339	1
18-4248	Arandela	311598	2
18-7100	Aro tórico	301877	1
18-7117	Aro tórico	303360	1
18-7120	Aro tórico	307853	1
18-2534	Retén	309044	1



18-2683
KIT RETENES UNIDAD INFERIOR

- CONTIENE -

Ref #	Desc.	O.E. #	Cant.
18-2023	Retén aceite	313282	2
18-2891	Junta alojamiento cojinete	303339	1
18-4248	Arandela	311598	2
18-7100	Aro tórico	301877	1
18-7117	Aro tórico	303360	1
18-7120	Aro tórico	307853	1
18-2534	Retén	309044	1



18-2684
KIT RETÉN UNIDAD INFERIOR

- CONTIENE -

Ref #	Desc.	O.E. #	Cant.
18-0882	Junta	304764	1
18-2032	Retén aceite	321788	1
18-4248	Arandela	311598	2
18-7100	Aro tórico	301877	1
18-7120	Aro tórico	307853	1
18-2031	Retén aceite	321787	1
18-2534	Retén	309044	1



18-2685
KIT RETÉN UNIDAD INFERIOR

- CONTIENE -

Ref #	Desc.	O.E. #	Cant.
18-2030	Retén aceite	321786	3
18-2031	Retén aceite	321787	1
18-4248	Arandela	311598	2
18-7100	Aro tórico	301877	1
18-7112	Aro tórico	302493	1
18-7120	Aro tórico	307853	1
18-2534	Retén	309044	1
18-0882	Junta	304764	1



18-8383
KIT RETENES
Reemplaza: 5000309
Para: E-Tec 40, 50, 60 HP



18-8384
KIT RETENES
Reemplaza: E-Tec
5006373
Para: E-Tec 75/90/115/150/175/200/225/250 HP



18-8387
KIT RETENES UNIDAD INFERIOR
Reemplaza: 5007987
Para: E-Tec 15, 25, 30 (2010 & sup)

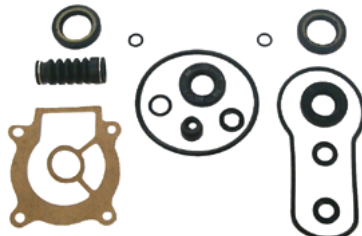

18-8337
KIT RETENES UNIDAD INFERIOR
Reemplaza: 5031456
Para: 40/50 HP 4 tiempos (1999-2003)

- CONTIENE -

Ref #	Desc.	O.E. #	Cant.
18-0461	Junta bomba agua	-	1
18-7151	Aro tórico	-	1
18-7413	Aro tórico	303191	2
18-8331	Junta	-	3
18-8334	Retén	-	1
18-8345	Retén	-	2



18-74108
KIT RETÉN ALOJAMIENTO ENGR.
Reemplaza: 5030973
Para: Johnson Evinrude 60/70 4-Tiempos



18-2686
KIT RETÉN UNIDAD INFERIOR

– CONTIENE –

Ref #	Desc.	O.E. #	Cant.
18-0882	Junta	304764	1
18-2005	Retén aceite	313284	1
18-2021	Retén aceite	302564	1
18-4248	Arandela	311598	2
18-7100	Aro tórico	301877	1
18-7115	Aro tórico	302588	1
18-7120	Aro tórico	307853, 322598	1



18-2687
KIT RETÉN UNIDAD INFERIOR

– CONTIENE –

Ref #	Desc.	O.E. #	Cant.
18-2005	Retén aceite	313284	1
18-4248	arandela	311598	2
18-7120	Aro tórico	307853, 322598	1
18-7152	Aro tórico	307082	1
18-2027	Retén aceite	321459	1
18-7143	Aro tórico	322501	1
18-0173	Retén aceite	313283	1
18-7428	Retén goma	307103	1



18-2688
KIT RETÉN UNIDAD INFERIOR

– CONTIENE –

Ref #	Desc.	O.E. #	Cant.
18-2027	Retén aceite	321459	2
18-2855	Junta alojamiento	314082	1
18-4248	Arandela	311598	2
18-7100	Aro tórico	301877	1
18-7109	Aro tórico	317178	4
18-7127	Aro tórico	313446	1
18-7128	Aro tórico	313754	1
18-2001	Retén aceite	330137	2
18-7129	Aro tórico	314491	1

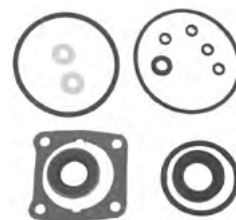

18-2689
KIT RETÉN UNIDAD INFERIOR

– CONTIENE –

Ref #	Desc.	O.E. #	Cant.
18-0173	Retén aceite	313283	1
18-0174	Retén aceite	326716	1
18-0886	Junta alojamiento	307099	1
18-4248	Arandela	311598	2
18-7115	Aro tórico	302588	1
18-7118	Aro tórico	305242	1
18-7120	Aro tórico	307853, 322598	4
18-7152	Aro tórico	307082	1
18-7428	Aro tórico	307103	1

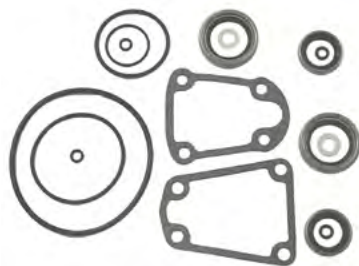

18-2690
KIT RETÉN UNIDAD INFERIOR

– CONTIENE –

Ref #	Desc.	O.E. #	Cant.
18-2855	Junta alojamiento	314082	1
18-2874	Junta tapa solenoide	314876	1
18-4248	Arandela	311598	2
18-7120	Aro tórico	307853, 322598	4
18-7127	Aro tórico	313446	1
18-7129	Aro tórico	314491	1
18-7130	Aro tórico	314728	1
18-7126	Aro tórico	313340	1



18-2691
KIT RETÉN UNIDAD INFERIOR

– CONTIENE –

Ref #	Desc.	O.E. #	Cant.
18-2874	Junta tapa solenoide	314876	1
18-4248	Arandela	311598	2
18-7109	Aro tórico	317178	4
18-7127	Aro tórico	313446	1
18-2001	Retén aceite	330137	2
18-7130	Aro tórico	314728	1
18-2059	Retén aceite	321466	2



18-2692
KIT RETÉN UNIDAD INFERIOR

– CONTIENE –

Ref #	Desc.	O.E. #	Cant.
18-0110	Junta alojamiento	324670	1
18-2026	Retén aceite	321453	2
18-2874	Junta tapa solenoide	314876	1
18-4248	Arandela	311598	2
18-7109	Aro tórico	317178	4
18-7120	Aro tórico	322598	1
18-7127	Aro tórico	313446	1
18-7130	Aro tórico	314728	1
18-7137	Aro tórico	318372	1
18-2001	Retén aceite	330137	2

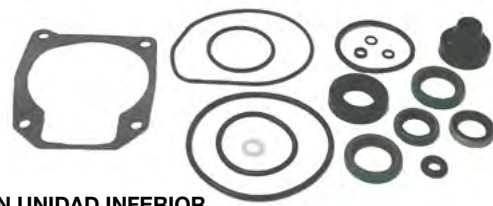

18-2694
KIT RETÉN UNIDAD INFERIOR
Reemplaza: 433550

– CONTIENE –

Ref #	Desc.	O.E. #	Cant.	Ref #	Desc.	O.E. #	Cant.
18-2709	Junta platina desgaste	336530	1	18-7481	Retén	315788	1
18-7115	Aro tórico	302588	1	18-2708	Retén	333758	1
18-7127	Aro tórico	313446	1	18-2059	Retén aceite	321466	2
18-7120	Aro tórico	307853, 322598	1	18-2018	Retén aceite	0767970	2
18-7172	Aro tórico	553126	1	18-2064	Retén aceite	332205	1
18-7137	Aro tórico	318372	1	18-2705	Retén	315748	1
18-7475	Aro tórico	332584	1	18-4248	Arandela	311598	1
				18-7173	Aro tórico	310327, 910582	1

APLICACIÓN KITS RETENES CAJA DE CAMBIO

Modelo	Año	kit retén	Modelo	Año	Kit retén		
5.5	⑧	1955-67	18-2679	85	1991-95	18-2623	
6	⑧	1955-67	18-2679	88	1985-sup	18-2623	
6	⑨	1967-68	18-2680	90 (Elect.)	1964-65	18-2689	
6	⑩	1968-79	18-2681	90 (V-4)	1973-83	18-2692	
7.5	⑧	1955-67	18-2679	90	1985-sup	18-2623	
9.5 (Sufijo M)		1964-67	18-2682	100 (eje largo) 1971-72	18-2691		
9.5 (Sufijo B)		1967-73	18-2683	100 (V-4)	1973-83	18-2692	
9.9/15		1974-Sup	18-2656	100 (Comm)	1984-90	18-2623	
9.9/15 (4 tiempos)		1974-Sup	18-2656	100 (Comm)	1991-95	18-2623	
10		1958-67	18-2682	100	③	1991-92	18-2623
18		1958-73	18-2684	110 (V-4)	1973-83	18-2692	
20		1966-73	18-2684	110	1985-89	18-2623	
20		1979-82	18-2684	115 (eje corto) 1969-71	18-2690		
20		1985-Sup	18-2658	115 (V-4)	1973-83	18-2692	
25		1955-59	18-2686	115	1985-Sup	18-2623	
25		1968-78	18-2684	120	1985	18-2623	
25		1979-82	18-2685	120	1986-92	18-2623	
25		1984	18-2657	120	1993	18-2623	
25		1985-Sup	18-2658	125 (eje largo)	1971-72	18-2691	
25	①	1990-95	18-2694	125	④	1991-92	18-2623
25 (Comm)		1985-Sup	18-2657	125	1993	18-2623	
28		1962-70	18-2686	125 (Comm)	1991-93	18-2623	
28		1985-98	18-2657	135 (V-4)	1973-83	18-2692	
30		1955-59	18-2686	140 (V-4)	1973-83	18-2692	
30		1976-95	18-2658	140	1985	18-2623	
33		1962-70	18-2686	140	⑤	1986-92	18-2623
35		1955-59	18-2686	140	⑥	1992-93	18-2623
35		1977-92	18-2658	140	①	1992-95	18-2623
40 (cambio manual) 1960-73		18-2686		150 (V-6)	1978-86	18-2623	
40 (cambio eléctrico)		1962-70	18-2687	150	⑦	1991	18-2623
40		1976-88	18-2659	150		1991-95	18-2623
40		1989-Sup	18-2694	155 (Comm)	1984-90	18-2623	
48		1976-88	18-2659	155 (Comm)	1991-93	18-2623	
48		1989-96	18-2694	175 (V-6)	1977-86	18-2623	
50		1971-74	18-2688	175	②	1991	18-2623
50		1976-88	18-2659	175	⑦	1992	18-2623
50		1989-Sup	18-2694	175		1991-95	18-2623
50 (3 cil.)		1995-Sup	18-2660	185		1991-93	18-2623
55		1968-69	18-2690	200 (V-6)	1976-86	18-2623	
55		1976-88	18-2659	200		1991-95	18-2623
60 (Manual/Elect.)		1960-68	18-2689	225		1991-95	18-2623
60		1970-71	18-2690	235 (V-6)	1977-86	18-2623	
60 (2 cil.)		1976-88	18-2659	V-8	⑦	1985-91	18-2623
60 (3 cil.)		1978-Sup	18-2660	250 (V-8)		1991-95	18-2623
65 (Manual/Elect.)		1960-68	18-2689	300 (V-8)		1991-95	18-2623
65		1978-Sup	18-2660	OMC SEA DRIVE			
70		1978-Sup	18-2660	1.6L	1985-90	18-2623	
75 (Manual/Elect.)		1960-68	18-2689	1.8L	1987	18-2623	
75		1978-91	18-2660	2.0L	1988-90	18-2623	
75 (Caja engranajes) 1976-88		18-2659		2.5L	1984-85	18-2623	
V-4		1978-84	18-2623	2.6L	1984-86	18-2623	
85 (Manual/Elect.)		1968	18-2689	2.7L	1987	18-2623	
85 (Eje pequeño) 1969-71		18-2690		3.0L	1988-90	18-2623	
85 (Eje largo) 1971-72		18-2691		3.6L	1987	18-2623	
85 (V-4)		1973-83	18-2692	4.0L	1989-90	18-2623	

- ① Sólo sufijos "D"
- ② Sólo modelos "GL" & "EX"
- ③ Modelos 1992 excepto WTLNE, WTXENE
- ④ Sólo modelos 1992 ESX

- ⑤ Sólo modelos 1992 TL
- ⑥ Solo modelos CX
- ⑦ 1992 Contra rotación
- ⑧ 1967 sólo sufijo "D"

- ⑨ 1967 sólo sufijo "S"
1968 sólo sufijo "C"
- ⑩ 1968 sólo sufijos "A" & "R"
- ① Modelos TX y contra la rotación

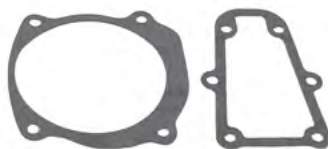

18-2595
JUEGO DE JUNTAS
Reemplaza: 982132

18-2595 APLICACIÓN DE JUEGO DE JUNTAS

HP	AÑOS	HP	AÑOS	HP	AÑOS
85	1978-80	120	1985-90	200	1976-90
88	1987-90	125	1989-90	225	1986-90
90	1981-90	140	1977-90	235	1978-85
100	1979-90	150	1978-90	275	1985-90
100C	1984-89	155C	1984-90	3.6L	1985-90
110	1986-89	175	1977-90	300	1985-90
115	1978-90	185	1984-90		

RETÉN ACEITE



Ref #	O.E. #	Medida eje	Dimensiones (pulg)		Ref #	O.E. #	Medida eje	Dimensiones (pulg)	
			D.E.	Ancho				D.E.	Ancho
18-0173	313283	0.795	1.320	0.307	18-2058	313353	1.938	2.438	0.250
18-0174	326716	0.750	1.382	0.242	18-2059	321466	0.750	1.126	0.200
18-0542	321831, 315288	0.750	1.253	0.186	18-2060	321467	1.000	1.375	0.250
18-0543	321895, 313507	1.540	1.926	0.243	18-2061	329922	0.822	1.375	0.195
18-0559	332585	0.285	0.357	0.940	18-2062	329923	0.875	1.375	0.207
18-2000	309989	1.375	2.000	0.313	18-2063	330327	0.625	1.124	0.188
18-2001	330137	1.125	1.624	0.250	18-2064	332205	0.730	1.130	0.194
18-2002	320862	1.188	1.692	0.250	18-2065	332261	0.625	1.375	0.195
18-2005	313284	0.625	1.128	0.250	18-2066	911019	1.000	1.375	0.435
18-2012	310599	1.000	1.499	0.250	18-2067	911685	2.000	2.509	0.315
18-2016	313992	1.187	1.875	0.250	18-2068	911701	0.500	0.905	0.250
18-2018	305987	1.000	1.375	0.250	18-2068	915702	0.500	0.905	0.250
18-2020	310649	2.500	3.000	0.250	18-2068	916058	0.500	0.905	0.250
18-2021	302564	0.750	1.375	0.250	18-2068	3853655	.500	.905	.250
18-2022	303345	0.554	1.000	0.375	18-2071	981195	1.500	2.125	0.250
18-2023	313282	0.554	1.062	0.312	18-2072	981196	1.750	2.502	0.250
18-2024	314167	0.425	0.937	0.312	18-2073	981268	1.625	2.502	0.250
18-2025	318972	0.500	0.875	0.250	18-2074	339620	1.625	2.125	0.250
18-2026	321453	0.875	1.250	0.188	18-2075	0353076	1.562	2.062	0.300
18-2027	321459	0.625	1.125	0.250	18-8300	341280	0.866	1.378	0.280
18-2028	318973	0.500	1.250	0.188	18-8301	341281	1.220	1.693	0.280
18-2029	321481	0.687	1.250	0.250	18-8304	321830	20.37mm	31.8mm	6.35mm
18-2030	321786	0.625	1.125	0.188	18-8307	331103	1.100	1.628	0.448
18-2031	321787	0.625	1.125	0.312	18-8325	342786	28mm	41.5mm	7/11
18-2032	321788	0.500	1.000	0.188	18-8326	342787	18mm	29mm	8/12
18-2033	321928	0.625	1.375	0.250	18-8349	911795			
18-2034	324639	0.437	0.937	0.188	18-8350	3852548	1.375	2.186	0.500
18-2035	327031	0.425	0.875	0.313	18-8351	328603	1.100	1.690	0.320
					18-8351	321504, 308500	1.110	1.570	0.320
					18-8367	334950	1.250	1.687	0.250

APLICACIÓN RETÉN ACEITE

HP	AÑOS	EJE HÉLICE	CANT.	EJE TRANSMISIÓN	CANT.	CÁRTER SUPERIOR	CANT.	CÁRTER SUPERIOR	CANT.
1.5,2,2.5,3	1958-68	-	1	18-2035	1	-	-	-	-
1.5,2	1968-90	18-2035	1	18-2035	1	-	-	-	-
2.5,4	② 1973-80	18-2035	1	18-2035	2	-	-	-	-
2.5	1987	18-2034	2	18-2035	2	-	-	-	-
2.5,4	② 1981-95	-	1	18-2035	2	-	-	-	-
3 Weedless	1958-68	18-2035	1	-	-	-	-	-	-
3,4,6 Weedless	1968-82	18-2024	1	18-2024	1	-	-	-	-
4	1981-90	18-2034	2	-	-	-	-	-	-
4	1984, 1986-95	-	-	18-2034	2	-	-	-	-
4.5,7.5	1980-87	-	1	18-2034	2	-	-	-	-
5.5,5,6,7.5	① 1957-64	18-2022	1	18-2035	1	-	-	-	-
5,6,8	1980-87	-	-	18-2034	2	-	-	-	-
6	1965-67	-	1	18-2023	1	-	-	-	-
6	1968-79	18-2023	1	18-2024	1	-	-	-	-
9.5	1964-73	18-2022	1	18-2022	1	-	-	-	-
9.9	1974-83	18-2029	1	18-2028	1	18-8304	-	18-0542	1
9.9	1984-95	18-2029	1	18-2028	1	18-8304	-	18-0542+18-2032	1
10	1957-58	18-2005	1	18-2032	1	-	-	-	-
10	1959-63	18-2022	1	18-2022	1	-	-	-	-

① 1968 Modelos 5802M,3M,6802C,3C

② Caja de engranajes estándar

APLICACIONES RETÉN ACEITE (Cont.)

HP	AÑOS	EJE HÉLICE	CANT.	EJE HÉLICE	CANT.	PARTE SUP. CIGÜENAL	CANT.	PARTE SUP. CIGÜENAL	CANT.
10	1981	18-2023 (interior)	1	-	-	18-8304	-	18-0542	1
10	1989	18-2031+18-2027	1	18-2063+18-2027	1	18-8304	-	18-0542+18-2032	1
14	1988-90	18-2031+18-2027	1	18-2063+18-2027	1	18-8304	-	18-0542+18-2032	1
15	1974-83	18-2029	2	18-2028	1	18-8304	-	18-0542	1
15	1984-95	18-2029	2	18-2028	1	18-8304	-	18-0542+18-2032	1
18	1957	18-2005	1	18-2032	1	18-2060	1	-	-
18	1958-73	18-2005	1	18-2032	1	18-2018	1	-	-
20	1981-82	18-2031+18-2030	1	18-2030	1	18-8351	-	-	-
20	1983	18-2031+18-2030	1	18-2027+18-2030	1	18-8351	-	-	-
20	1984	18-2025+18-2027	1	18-2063+18-2030	1	18-8351	-	-	-
20	1985-86	18-2026	1	18-2033	1	18-8350	-	-	-
20	1987-95	18-2026	1	18-2033+18-2065	1	18-8350	-	-	-
25	1969-76	18-2005	1	18-2032	1	18-2018	1	-	-
25	1977-78	18-2005	1	18-2032	1	18-8351	-	-	-
25	1979-82	18-2031+18-2030	1	18-2030	1	18-8351	-	-	-
25	1983	18-2031+18-2030	1	18-2027+18-2030	1	18-8351	-	-	-
25	1984	18-2031+18-2027	1	18-2063+18-2030	1	18-8351	-	-	-
25	1985-86	18-2026	1	18-2033	2	18-8351	-	-	-
25	1987-95	18-2026	1	18-2033+18-2065	1	18-8351	-	-	-
25C	1982	18-2030	1	18-2030	1	18-8351	-	-	-
25C	1983	18-2031+18-2027	1	18-2027+18-2030	1	18-8350	-	-	-
25C	1984-90	18-2031+18-2027	1	18-2063+18-2027	1	18-8350	-	-	-
28	1962-64	18-2021	1	18-2005	1	18-8351	-	-	-
28	1987-90	18-2031+18-2027	1	18-2063+18-2027	1	18-8350	-	-	-
30	1984-86	18-2026	1	18-2033	1	18-8350	-	-	-
30	1987-95	18-2026	1	18-2033 (Interior)	1	18-8350	-	-	-
33	1965-76	18-2021	1	18-2005	1	18-8351	-	-	-
35	1957-59	18-2021	1	18-2005	1	18-2018	1	-	-
35	1976	18-2026	1	18-2027	2	18-8351	-	-	-
35	1977-86	18-2026	2	18-2033	2	18-8351	-	18-2093	-
35	1987-90	18-2026	2	18-2033 (Interior)	1	18-8350	-	18-2093	-
40	1960-61	18-2021	1	18-2005	1	18-2018	1	-	-
40	1962-73	18-2021	1	18-2005	1	18-8351	-	-	-
40	1974-76	18-2021	1	18-2029	1	18-0543	1	18-2001	1
40C	1981-86	18-2021	1	18-2029	2	18-0543	1	18-2001	2
40	1984-85	18-2060	2	18-2059	2	18-0543	1	18-2001	1
40 (AR,AE,AT)	1988	18-2001	1	18-2063+18-2027	1	18-0543	1	18-8307	-
40	1986-89	18-2060	2	18-2064+18-2059	1	18-0543	1	18-8307	-
45C	1985	18-2001	2	18-2063+18-2027	1	18-0543	1	18-8307	-
45C	1986	18-2001	2	18-2064+18-2059	1	18-0543	1	18-8307	-
45C	1987	18-2001	2	18-2063+18-2027	1	18-0543	1	18-8307	-
45C	1988-94	18-2001	2	18-2063+18-2027	1	18-0543	1	18-2001	-
45C	1995	18-2001	2	18-2064+18-2059	1	18-0543	1	-	-
48	1988-95	18-2060	2	18-2064+18-2059	1	18-0543	1	18-2063 (Interior)	1
50	1971-74	18-2001 (Manual)	2	18-2027	2	18-0543	1	18-2001	1
50	1975	18-2060	2	18-2059	1	18-0543	1	18-2001	1
50	1979	18-2001	2	18-2027	2	18-0543	1	18-2001	1
50	1980	18-2060	2	18-2059	1	18-0543	1	18-2001	1
50/60 (arranq.man)	1981-83	18-2001	2	18-2027	1	18-0543	1	18-2001	1
50/60 (Electrico)	1981-83	18-2060	2	18-2059	1	18-0543	1	18-2001	1
50/60	1984-85	18-2060	2	18-2059	1	18-0543	1	18-2001	1
50/60 caja engr. pequeña	1986-87	18-2060	2	18-2064+18-2059	1	18-0543	1	18-2001	1
50/60 caja eng.grande	1986-87	18-2001	2	18-2064+18-2059	1	18-0543	1	18-2001	1
50/60	1988-89	18-2001	2	18-2064+18-2059	1	18-0543	1	18-2001	1
50	1990-95	18-2060	2	18-2064+18-2059	1	18-0543	1	18-2063 (Interior)	1
55	1968-69	18-2012	2	18-2059	2	18-0543	1	18-2001	1
55	1976-77	18-2060	2	18-2059	2	18-0543	1	18-2001	1
55	1978	18-2059	1	18-2059	2	18-0543	1	18-2001	1
55	1979-83	18-2001	2	18-2027	1	18-0543	1	18-2001	1
55 (Electrico)	1980-83	18-2012	2	18-2059	2	18-0543	1	18-2001	1
55C	1984	18-2001	2	18-2063+18-2027	1	18-0543	1	18-2001	1
55C	1985	18-2001	2	18-2063	1	18-0543	1	18-2001	1
55C	1986	18-2001	2	18-2064+18-2059	1	18-0543	1	18-8307	-
55C	1987-94	18-2001	2	18-2063+18-2027	1	18-0543	1	18-8307	-
55C	1995	18-2001	2	18-2064+18-2059	1	18-0543	1	-	-
60 (Manual Shift)	1964-68	18-0173	1	18-0174	1	-	-	-	-
60	1970	18-2012	1	18-2059	2	18-0543	1	18-2001	1
60 (3 Cilindro)	1971	18-2001	2	18-2059	2	18-0543	1	18-2001	1
60 (manual)	1980-83	18-2001	2	18-2027	2	18-0543	1	18-2001	1

Retén aceite
JOHNSON / EVINRUDE (OMC/BRP)

APLICACIÓN RETÉN ACEITE (Cont.)

HP	AÑOS	EJE HÉLICE	CANT.	EJE TRANSMISIÓN	CANT.	PARTE SUP. CIGÜEÑAL	CANT.	PARTE. INF. CIGÜEÑAL	CANT.
60 (Eléctrico)	1980-83	18-2001	2	18-2059	2	18-0543	1	18-2001	1
60	1984-85	18-2060	2	18-2059	2	18-0543	1	18-2001	1
60SST	1989	18-2060	2	18-2064+18-2059	1	18-0543	1	18-2001	1
60SST	1990	18-2060	2	18-2064+18-2059	1	18-0543	1	18-8307	-
60 (3 Cilindros)	1987-95	18-2001	2	18-2064+18-2059	1	18-0543	1	18-8307	-
65 (Manual)	1968	18-0173	1	18-0174	1	18-0543	1	-	-
65 (3 Cilindros)	1972-73	18-2001	2	18-2059	2	18-0543	1	18-2001	1
65C	1984-85	18-2001	2	18-2059	2	18-0543	1	18-2001	1
65C	1986-89	18-2001	2	18-2064+18-2059	1	18-0543	1	18-2001	1
70 (caja engr. grande)	1974-85	18-2001	2	18-2059	2	18-0543	1	18-2001	1
70 (Caja engr. grande)	1986-95	18-2001	2	18-2064+18-2059	1	18-0543	1	18-8307	-
70 Caja engr. pequeña	1977-85	18-2060	2	18-2059	2	18-0543	1	18-8307	-
75 (Manual)	1960-62	18-0173	1	18-0174	1	-	-	-	-
75 (caja engr. grande)	1975-84	18-2001	2	18-2059	2	18-0543	1	18-2001	1
75 (caja engr. grande)	1986-87	18-2001	2	18-2064+18-2059	1	18-0543	1	18-8307	-
75 (caja engr. pequeña)	1975-84	18-2060	2	18-2059	2	18-0543	1	18-2001	1
80	1966-68	18-0173	1	18-0174	1	-	-	-	-
85	1969-70	18-2012	2	18-2059	2	18-2074	1	18-2001	1
85	1971-72	18-2001	2	18-2059	2	18-2074	1	18-2001	1
85	1973-80	18-2001	2	18-2026	2	18-2074	2	18-2001	1
88	1987-94	18-2001	2	18-2061+18-2062	1	18-2074	2	18-8307	-
90	1981-83	18-2001	2	18-2026	2	18-2074	2	18-2001	1
90	1984-94	18-2001	2	18-2061+18-2062	1	18-2062	1	18-8307	-
90 Seadrive	1985-90	18-2001	2	18-2061+18-2062	1	18-2074	2	18-2001	1
100	1971-72	18-2001	2	18-2059	2	18-2074	1	18-2001	1
100	1979-80	18-2001	2	18-2026	2	18-2074	2	18-2001	1
100C	1984-90	18-2002	2	18-2061+18-2062	1	18-2074	2	18-8307	-
110	1986-88	18-2001	2	18-2061+18-2062	1	18-2074	2	18-2001	1
115	1969-70	18-2012	2	18-2059	2	18-2074	1	18-2001	1
115	1973-83	18-2001	2	18-2026	2	18-2074	1	18-2001	1
115	1984-85	18-2001	2	18-2061+18-2062	1	18-2074	2	18-2001	1
115	1990-94	18-2001	2	18-2061+18-2062	1	18-2074	2	18-8307	-
120	1985	18-2002	2	18-2061+18-2062	1	18-2074	2	18-2075	2
120	1986-88	18-2001	2	18-2061+18-2062	1	18-2074	2	18-2075	2
120	1989	18-2002	2	18-2061+18-2062	1	18-2074	2	18-2075	2
120	1990-94	18-2001	2	18-2061+18-2062	1	18-2074	2	18-2075	2
125	1971-72	18-2001	2	18-2059	2	18-2074	1	18-2001	1
125C	1989	18-2002	2	18-2061+18-2062	1	18-2074	2	18-2075	1
125C (ESX modelos)	1989	18-2001	2	18-2061	1	18-2062	1	18-2075	1
135	1973-76	18-2001	2	18-2026	2	18-2074	2	18-2001	1
140	1977-83	18-2001	2	18-2026	2	18-2074	2	18-2001	1
140	1984	18-2001	2	18-2026	2	18-2074	2	18-2001	1
140	1985	18-2002	2	18-2061+18-2062	1	18-2074	2	18-2075	2
140	1986-94	18-2001	2	18-2061+18-2062	1	18-2074	2	18-2075	2
140TX	1989	18-2002	1	18-2061+18-2061	1	18-2074	2	18-2075	2
150	1978-83	18-2002	2	18-2026	2	18-2074	2	18-2075	2
150	1984	18-2002	2	18-2061+18-2062	1	18-2074	2	18-2075	2
150	1985-90	18-2002	2	18-2061+18-2062	1	18-2074	2	18-8307	-
155C	1984-85	18-2002	2	18-2061+18-2062	1	18-2074	2	18-2001	1
155C	1986-90	18-2002	2	18-2061+18-2062	1	18-2074	2	18-8307	-
175	1977-85	18-2002	2	18-2026	2	18-2074	2	18-2001	1
175	1986-90	18-2002	2	18-2061+18-2062	1	18-2074	2	18-8307	-
185	1984-85	18-2002	2	18-2061+18-2062	1	18-2074	2	18-2001	1
185	1990	18-2002	2	18-2061+18-2062	1	18-2074	2	18-2075	1
200	1976-83	18-2002	2	18-2026	2	18-2074	2	18-2001	1
200	1984-85	18-2002	2	18-2061+18-2062	1	18-2074	2	18-8307	-
200,225	1986-90	18-2002	2	18-2061+18-2062	1	18-2074	2	18-2075	2
235	1978-83	18-2002	2	18-2026	2	18-2074	2	18-2001	1
235	1984-85	18-2002	2	18-2061+18-2062	1	18-2074	2	18-2001	1
275	1985-88	18-2002	2	18-2061+18-2062	1	18-2074	2	18-2075	2

APLICACIÓN RETÉN ACEITE - ALOJAMIENTO EJE TRANSMISIÓN

HP	Años	Sierra Retén aceite	Cant.	Desc.	HP	Años	Sierra Retén aceite	Cant.	Desc.
5/6/6.5/8 ①	1987-90	18-2034	1	EH,L	75/80/85	1961-68	18-2060	1	PS
45/55 ①	1990	18-2063	1	EH A	90/100	1964-68	18-2060	1	PS
50/60/65	1958-68	18-2060	1	PS					

① También modelos comerciales
PS Pivote

EH A Alojamiento escape a adaptador
EH,L Eje transmisión a alojamiento de escape

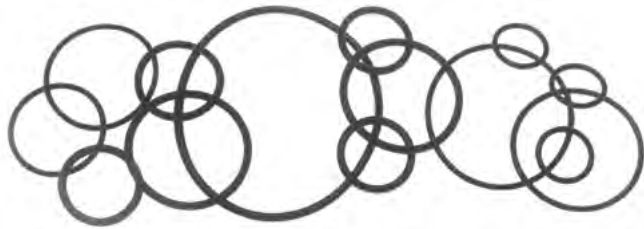

AROS

Ref #	O.E. #	Dimensiones (pulg)		Ref #	O.E. #	Dimensiones (pulg)	
		D.I.	Ancho			D.I.	Ancho
18-7100	25	301877	.245 .155	18-7145	25	333572	.250 .100
18-7101	25	305739	.250 .065	18-7146	25	554545	1.120 .100
18-7102	25	307450	.430 .065	18-7150	35	303598	.225 .115
18-7103	25	308624	.924 .103	18-7150	35	331380	.225 .115
18-7104	25	308627	2.210 .135	18-7150	35	334913	.225 .115
18-7105	25	311338	.750 .065	18-7152	25	307082	2.625 .135
18-7107	25	313175	4.750 .135	18-7153	25	911851	.862 .103
18-7108	25	313893	2.550 .100	18-7153	25	3852565	.862 .103
18-7108	25	338518	2.550 .100	18-7155	25	305270	1.620 .135
18-7109	25	317178	.214 .048	18-7156	25	309731	1.185 .100
18-7111	1	301824	.197 .113	18-7158	25	310967	.740 .100
18-7112	1	302493	1.170 .135	18-7158	25	310585	.740 .100
18-7114	2	302540	1.000 .135	18-7162	25	302337	2.025 .135
18-7115	1	302588	1.735 .135	18-7164	25	302537	1.375 .100
18-7116	1	303067	.360 .100	18-7165	25	304174	.500 .065
18-7117	1	303360	1.060 .135	18-7167	25	310414	3.625 .135
18-7118	25	305242	.300 .135	18-7168	25	202893	.370 .065
18-7120	1	307853	.215 .065	18-7169	25	911686	3.500 .135
18-7121	1	308621	3.100 .135	18-7170	25	307239	1.359 .139
18-7123	1	308876	2.235 .100	18-7172	25	553126	3.250 .135
18-7126	1	313340	1.690 .100	18-7173	25	310327	1.875 .135
18-7127	1	313446	3.315 .135	18-7174	25	910582	.620 .100
18-7128	1	313754	1.835 .100	18-7174	25	326649	.620 .100
18-7129	25	314491	.970 .065	18-7178	25	320140	.920 .135
18-7130	1	314728	2.125 .100	18-7180	25	303347	.445 .090
18-7133	25	305123	3.780 .135	18-7198	25	308626	1.430 .100
18-7133	25	322119	3.780 .135	18-7400	25	908194	4.000 .100
18-7134	25	303059	.500 .100	18-7401	25	908383	2.485 .100
18-7135	1	310584	.750 .135	18-7403	25	909316	1.500 .100
18-7137	25	318372	0.320 .155	18-7404	25	909747	.300 .100
18-7138	25	318717	1.500 .210	18-7406	25	911311	0.250 .065
18-7139	25	319085	1.080 .210	18-7407	25	911700	4.125 .135
18-7140	25	320303	2.750 .135	18-7407	5	3852531	4.125 .135
18-7141	25	321117	.180 .065	18-7408	25	911718	1.060 .100
18-7142	2	322119,	3.940 .135	18-7409	25	911871	1.175 .100
18-7143	25	322501,		18-7411	25	321921	1.237 .103
		331188	1.310 .100	18-7413	25	303191	.301 .070
18-7144	25	326849	4.250 .135	18-7416	25	329380	.612 .103
				18-7417	25	329381	.362 .103
				18-7418	25	326741	4.484 .139
				18-7440-1	4	301967	.799 .103
				18-7457	1	319662	1.799 .103
				18-7461	1	308458	1.612 .103
				18-7475	15	332584	.250 .065
				18-7477	25	909048	.480 .100
				18-7510	5	321163	2.750 .070

① ENV. DE 1 ② ENV. DE 5 ③ ENV. DE 10 ④ ENV. DE 2 ■ Indica aros quad
 ⑤ Precio por pieza. Para pedir envasado añadir -9 a la referencia.

BLOQUE MOTOR

HP	AÑOS	AROS	CANT	DESC
5.5	1959	18-7180	1	L C
9.5	1964-73	18-7156	1	U C
18	1957-72	18-7114	1	CCH
18/25	1957-76	18-7164	1	LL C
20/25 ①	1977,79-90	18-7174	1	L C
20/25	1990-95	18-7146	1	CCH O
25/35	1957,69-76	18-7114	1	CCH
25/18	1971-76	18-7164	1	U C
25 ⑥	1989-90	18-7123	1	CCH
25 ⑥	1989-90	18-7457	1	U C
25/35	1978	18-7134	1	L C
28	1962-64	18-7164	1	LL C
28/30/35	1976-77,79-90	18-7174	1	L C
28/30/35	1990-95	18-7146	1	CCH O
33/35/40	1957-75	18-7164	1	LL C
35	1987	18-7128	1	U C
35	1987	18-7123	1	CCH
40/45 ①	1976,81-95	18-7123	1	CCH
40) ①	1976,81-95	18-7128	1	U C
45/45SS ①	1985-95	18-7128	1	U C
45SS/48	1987-95	18-7123	1	CCH
48/50/55 ①	1971-95	18-7128	1	U C
50	1958-59	18-7133	1	CCH
50/55 ①	1968-90	18-7123	1	CCH
55/60	1968-71	18-7117	1	CCH O
60/65/75/80	1960-68	18-7133	2	CCH
60/SST60	1970-71,81-95	18-7128	1	U C
60/SST60	1970-95	18-7123	1	CCH
60/SST60	1989-90	18-7158	1	L C
65 ①	1972-73,85-95	18-7123	1	CCH
65 ①	1972-73,85-95	18-7128	1	U C
65/70 ①	1989-90	18-7158	1	L C
70	1974-90	18-7123	1	CCH
70	1974-90	18-7128	1	U C
75	1975-88	18-7128	1	U C
75	1975-88	18-7123	1	CCH
V-4	1969-71	18-7117	1	CCH O
85)	1968-80	18-7133	4	CCH
88/90/100 ①	1964,81-95	18-7133	4	CCH
100	1966	18-7120	4	CCHS
110/115	1969-95	18-7133	4	CCH
125/135/140	1971-84	18-7133	4	CCH
150/155/175 ①	1977-90	18-7133	4	CCH
200/235/185	1976-85	18-7133	4	CCH

CCH S Tornillo cigüeñal
L C Parte inferior cigüeñal
LL C Parte larga cigüeñal
① Sólo modelos comerciales

CCH O Cabeza externa cigüeñal
U C Parte superior cigüeñal
CCH Cabeza cigüeñal
⑥ 89 Modelos DR, DE, DT

POWERHEAD

HP	AÑOS	AROS	CANT	DESC
4	1969-90	18-7111	1	FC
5 hasta 300 ①	1957-90	18-7111	2	FC
20/25/30	1984-86	18-7101	1	EPMV
35/40	1984-86	18-7101	1	EPMV
45 ①	1986-87	18-7101	1	EPMV
50	1985-86	18-7101	1	EPMV
55 ①	1986-88	18-7101	1	EPMV
60/65/70 ①	1985-86	18-7101	1	EPMV
75	1983-86	18-7101	1	EPMV
V-4/6 ①	1980-86	18-7101	1	EPMV
200/225	1986-88	18-7115	1	EPP
V-8	1985-86	18-7115	1	EPP

① También modelos comerciales
EPMV Válvula manual
FC Conector combustible
EPP Bomba eléctrica

POWER TILT Y TRIM

HP	AÑOS	AROS	CANT	DESC
35/40/45 ①	1986-89	18-7168	1	LA
45SS	1988-90	18-7134	1	TEC
45SS	1988	18-7141	4	OL
50/55/60 ①	1981-89	18-7168	1	LA
60/70/75	1981-90	18-7174	2	MVS,L
60/70/75	1981-90	18-7141	4	OL
60/70/75	1981-90	18-7165	2	MVS,S
60/70/75	1981-90	18-7102	1	FP
70/75	1981	18-7174	1	TR
V-4/6 ①	1977-79	18-7168	3	RV
V-4/6 ①	1977-90	18-7174	1	TR
V-4/6/8	1977-90	18-7174	2	MVS,L
V-4/6/8 ①	1977-90	18-7102	1	FP
V-4/6/8 ①	1977-90	18-7165	2	MVS,S
V-4/6/8 ①	1977-90	18-7141	4	OL
85	1976-79	18-7168	1	LA
115/135	1974-77	18-7168	1	LA
200	1976	18-7168	3	RV
200/300	1990	18-7168	3	RV

① También modelos comerciales
TEC Tapa final trim a barra
LA Línea montaje
RV Válvula alivio
MVS,L Asiento válvula colector largo
MVS,S Asiento válvula colector pequeño
TR Barra trim
OL Línea aceite
FP llenado tapón

DIRECCIÓN

HP	AÑOS	Aros	Cant	DESC
60/70/75	1981-90	18-7168	4	CP
V-4/6/8	1980-90	18-7168	4	CP
V-6/8	1986-90	18-7129	2	SC
V-6/8	1986	18-7135	3	PVHT

CP Pistón control bomba
RV Válvula alojamiento bomba
SV Válvula
SC Cilindro
PVHT Retén pistón a válvula

ALOJAMIENTO EJE TRANSMISIÓN

HP	AÑOS	AROS	CANT	DESC
2.5	1987-88	18-7101	1	SS
4	③ 1981-90	18-7101	1	SS
4	② 1984,86-90	18-7168	1	K&S
4	④ 1984,86-90	18-7146	2	SB
4.5	1980-84,86-87	18-7168	1	K&S
4.5	1980-87	18-7146	2	SB
4.5	1980	18-7146	1	EHC
5	1984-90	18-7168	1	K&S
5	1984-90	18-7146	2	SB
6	1984-90	18-7168	1	K&S
6	1984-90	18-7146	2	SB
6.5	① 1989-90	18-7168	1	K&S
6.5	① 1989-90	18-7146	2	SB
7.5	1980-83	18-7146	2	SB
7.5	1980-83	18-7168	1	K&S
7.5	1980	18-7146	1	EHC
8	1984-90	18-7146	2	SB
8	1984-90	18-7168	1	K&S
28	1962-64	18-7115	1	SB
33	1965-70	18-7115	1	SB
35	1959	18-7114	1	PS
40	1960-70	18-7102	1	SS
40	1961-70	18-7114	1	PS
40	⑤ 1971-76,81-90	18-7115	1	SB
45SS	1987,88	18-7115	1	SB
60	1964-67	18-7180	4	SA
65	1968	18-7180	4	SA
75	1960-61,64-65	18-7180	4	SA
80	1966-67	18-7180	4	SA

ALOJAMIENTO EJE DE TRANSMISIÓN (Cont.)				
HP	AÑOS	AROS	CANT	DESC
85	1968	18-7180	4	SA
90	1964-65	18-7180	4	SA
100	1966-68	18-7180	4	SA
① Comercial ② Sólo modelos "RD" ③ Sólo modelos "BR" "RL" "RC" "RE" ④ Sólo modelos "R" "RD" ⑤ '82-'90 Comercial EHC tapa alojamiento escape K&S Soporte PS Pivote SS Pasador SA Amortiguador SB Soporte				

CAJA DE ENGRANAJES

HP	AÑOS	AROS	CANT	DESC
1.5/2	1968-90	18-7173	1	PBH
2/2.5/4	1988-90	18-7145	1	D&F S
3/4	1957-79	18-7168	1	DS CC
3/4 caja engr. estánd.	1964-80	18-7173	1	PBH
4	1981-95	18-7162	1	PBH
4 RD Modelos	1984,86-95	18-7118	1	SR
4.5	1980-87	18-7118	1	SR
5/5.5	1957-68	18-7180	1	DS BH
5	1965-68	18-7173	1	PBH
5/6/108	1984-95	18-7118	1	SR
5/6/6.5/8 6.5 HP Comm	1988-95	18-7145	2	D&F S
5/6/108	1989-95	18-7168	1	WT E
5.5/6	1957-79	18-7100	1	SR
5.5/6/7.5	1957-79	18-7117	1	PBH
5.5	1964	18-7120	1	SR PP
6/7.5	1957-79	18-7180	1	DS BH
6	1965-79	18-7120	1	SR PP
6.5/7.5 7.5 HP Comm	1980-90	18-7118	1	SR
6.5 Comm	1989-90	18-7168	1	WT E
7.5/9.5	1957-73	18-7100	1	SR
9.5/10	1958-73	18-7117	1	PBH
9.5	1964-73	18-7120	1	SR PP
9.5	1965-66,68,70-73	18-7168	1	WT E
9.5/9.9/15	1974-84	18-7116	1	DS CC
9.9/15	1974-95	18-7100	1	SR
9.9/15	1974-95	18-7168	1	WT E
9.9/15	1974-90	18-7104	1	PBH
9.9/15	1974-90	18-7139	1	IH
9.9/15	1984-85	18-7120	1	SR PP
9.9/15	1986-95	18-7475	1	SR PP
9.9/15	1988-92	18-7145	2	D&F S
9.9/15	1993-96	18-4248	2	D&F S
10	1957	18-7112	1	PBH
10/14	1957-63,88-90	18-7100	1	SR
10/18/25	1957-77	18-7116	1	DS CC
10/14 Comm	1988-90	18-7145	2	D&F S
14 Comm	1988-89	18-7475	1	SR PP
15A	1987-90	18-7174	1	WT
18/25	1957-76	18-7112	1	PBH
18/20/25	1957-95	18-7100	1	SR
18/20/28	1964-85	18-7120	1	SR PP
20/25	1977,85-95	18-7105	2	IH S
20/25	1985-90	18-7146	1	IH
20/25	1985-95	18-7180	1	SR S
20/25	1985-95	18-7108	1	PBH
20/25	1986-95	18-7475	1	SR PP
20/25/30	1987-95	18-7475	2	PBH S
20/25/28	1988-95	18-7145	2	D&F S
20/25	1988-95	18-7100	1	IH
20/30	1990	18-7475	1	BS
25	1969-86	18-7120	1	SR PP
25	1977	18-7109	2	PBH S
25	1978	18-7134	1	DS CC
25	1989-95	18-7475	1	BS
25	1989-90	18-7172	1	PBH
25	1989-90	18-7109	1	SR PP
25	1989-90	18-7173	1	DS BH

CAJA DE ENGRANAJES (Cont.)				
HP	AÑOS	AROS	CANT	DESC
25	1989-90	18-7137	1	SR
28/33	1962-63,65-67	18-7165	1	WT E
28/33	1962-70	18-7134	1	DS CC
28/33/35	1962-70	18-7115	1	PBH
28	1963-64	18-7100	1	SR
28	1987-95	18-7475	1	SR PP
30/35/33	1965-70,84-85	18-7120	1	SR PP
30/33	1965-95	18-7100	1	SR
30/35	1976-86	18-7109	2	PBH S
30/35	1976-95	18-7108	1	PBH
30/35	1976-95	18-7105	2	IH S
30/35	1983-95	18-7180	1	SR S
30	1984-90	18-7146	1	IH
30/35	1986-95	18-7475	1	SR PP
30/35	1986-95	18-7100	1	IH
30/35	1987-95	18-7145	2	D&F S
35	1957-58	18-7165	1	WT E
35	1957-59,87	18-7134	1	DS CC
35/40	1957-90	18-7100	1	SR
35	1976-77	18-7174	1	DS CC
35	1983-84,86-90	18-7146	1	IH
35	1987	18-7140	1	PBH
35	1987	18-7137	1	SR
35	1987	18-7115	1	DS BH
35	1987,90	18-7475	1	BS
35	1987-90	18-7475	2	PBH S
40	1960-85,89-90	18-7115	1	PBH
40/48	1960-88	18-7134	1	DS CC
40	1962-70	18-7152	1	PBH
40	1965-66,71,73-85	18-7120	1	SR PP
40	1966,70	18-7120	4	PBH S
40	1971,73-76,81-85	18-7165	1	WT E
40	1984	18-7109	4	PBH S
40/45	1984-86	18-7120	1	BS
40/48	1984-88	18-7140	1	PBH
40/48	1984-88	18-7115	1	DS BH
40/45 45 HP Comm	1984-95	18-7137	1	SR
40/45 45 HP Comm	1987-95	18-7475	1	BSS
40/50	1988-95	18-7145	2	D&F S
40/48/50	1989-90	18-7109	1	SR PP
40 Comm	1989-90	18-7165	1	WT E
40 Comm	1989-90	18-7475	1	SR PP
40/48/50	1989-95	18-7172	1	PBH
40/48/50	1989-95	18-7173	1	DS BH
45 Comm	1985-88	18-7134	1	IH
45 Comm	1985-95	18-7128	1	DS BH
45 Comm	1985-95	18-7127	1	PBH
45/48 45 HP Comm	1987-95	18-7145	2	D&F S
45SS	1987-90	18-7134	2	DS CC
45 Comm	1995	18-7475	4	PBH S
48	1987-88	18-7475	3	PBH S
48/50	1987-95	18-7475	1	BS
48	1987-95	18-7137	1	SR
50/60	1958-67	18-7118	1	SR
50/60/65	1958-68	18-7174	1	WT E
50/55	1958-69	18-7174	1	DS CC
50/55/60	1968-71	18-7126	1	DS BH
50/55	1968-72	18-7129	1	PS OP
50	1971	18-7100	1	SR
50	1971-74,79,81	18-7127	1	PBH
50	1971-81	18-7128	1	DS BH
50/55/60	1971-84	18-7109	4	PBH S
50/55	1971-88	18-7134	1	DS CC
50	1973-74	18-7156	2	SA,L
50	1973-74	18-7146	1	SA,S
50/55	1973-95	18-7137	1	SR
50	1975,79,81,			

CAJA ENGRANAJES (Cont.)

CAJA ENGRANAJES (Cont.)

HP	AÑOS	AROS	CANT	DESC	HP	AÑOS	AROS	CANT	DESC
	82-88	18-7115	1	DS BH	V-4	1966-68	18-7118	1	SR
50	⑧ 1975,79,81-88	18-7140	1	PBH	V-4	1966-68	18-7120	1	SR PP
50/60	1981-86	18-7120	1	BSS	80	1967	18-7120	4	PBH S
55	① 1968-69,79-81, 83-95	18-7127	1	PBH	V-4	1968-95	18-7127	1	PBH
55	⑩ 1976-82	18-7140	1	PBH	V-4	1969-72	18-7129	1	PS OP
55	⑩ 1976-82	18-7115	1	DS BH	V-4/6/8	1969-95	18-7130	1	DS BH
55	⑨ 1979-81,83-95	18-7128	1	DS BH	V-4	1971-86	18-7109	4	PBH S
55	⊕ 1981-88	18-7120	1	BS	V-4	1973-74	18-7146	1	SA,S
55 Comm	1988,90-95	18-7475	4	PBH S	V-4	1973-77	18-7156	2	SA,L
55 Comm	1989-95	18-7475	1	BS	V-4/6/8	1973-95	18-7137	1	SR
55 Comm	1989-95	18-7145	2	D&F S	V-4,6,8	1973-90	18-7158	1	DS CC
60 71 "E" Modelos	1964,66-67, 70-71	18-7120	4	PBH S	V-4	1975-77	18-7178	1	SA,S
60	⑦ 1964-67,80-87	18-7115	1	DS BH	V-4	1981-86	18-7120	1	BS
60/65/75 Caja engr. estándar	1964-68	18-7152	1	PBH	V-4/6	1987-95	18-7475	4	PBH S
60	1964-71,86-88	18-7174	1	DS CC	V-4/6/8	1987-95	18-7145	2	D&F S
60 67 Caja engr. estándar	1966-67	18-7120	1	SR PP	85/90	1964-68	18-7152	1	PBH
60/65	1968-71	18-7129	1	PS OP	100	1966-68	18-7167	1	PBH
60	③ 1970-81,86-95	18-7127	1	PBH	100	1984-90	18-7142	1	PBH
60	⑨ 1980-81,86-95	18-7128	1	DS BH	100 Comm	1986-90	18-7475	1	BS
60	1980-85	18-7134	1	DS CC	100 Comm	1987	18-7109	4	PBH S
60	② 1980-87	18-7140	1	PBH	120	1985	18-7142	1	PBH
60/SST60	1980-95	18-7137	1	SR	125	1971	18-7173	1	PBH
60/SST60/					125 Comm	1989-90	18-7142	1	PBH
65 65 HP Comm	1987-95	18-7475	1	BS	125 Comm	1990	18-7174	1	WT
60/SST60/					140	1985,88-90	18-7142	1	PBH
65 65 HP Comm	1987-95	18-7145	2	D&F S	V-6	1976-78	18-7178	1	SA,S
SST60	1989-90	18-7140	1	PBH	V-6	1976-78	18-7156	2	SA,L
SST60	1989-90	18-7174	1	DS CC	V-6	1976-85	18-7109	4	PBH S
60/65/70 65 HP Comm	1989-90	18-7158	1	DS CC	V-6	1976-90	18-7142	1	PBH
SST60	1989-90	18-7115	1	DS BH	V-6	1986	18-7120	1	BS
65/75	1960-68	18-7118	1	SR	155	⑨ 1984,89-90	18-7142	1	PBH
65 Caja engr. estándar.	1968	18-7120	1	SR PP	155	③ 1984-90	18-7144	3	PBH
65 Caja engr. estándar.	1968	18-7115	1	DS BH	200/225	1987	18-7120	1	BS
65	⊕ 1968-73, 85-88,90	18-7174	1	DS CC	V-8	1985-86	18-7120	1	BS
65	⊕ 1971,73,85-86	18-7109	4	PBH S	V-8	1985-90	18-7144	3	PBH
65	⊕ 1972-73,85-95	18-7127	1	PBH	V-8	1985-90	18-7174	1	WT
65	⊕ 1973,85-95	18-7137	1	SR					
65	⊕ 1973,85-95	18-7128	1	DS BH					
65/70 75 "B" Modelos	1973-75	18-7156	2	SA,L					
65/70 75 "B" Modelos	1973-75	18-7146	1	SA,S					
65 Comm	1985-86	18-7120	1	BS					
65/70 65 HP Comm	1988-95	18-7475	4	PBH S					
70/75	1960-65,74-88	18-7174	1	DS CC					
70/75	1974-85	18-7109	4	PBH S					
70/75	1974-95	18-7137	1	SR					
70	⑦ 1974-95	18-7128	1	DS BH					
70	⑦ 1974-95	18-7127	1	PBH					
70 15" Transom	1977-85	18-7115	1	DS BH					
70 15" Transom	1977-85	18-7140	1	PBH					
70	1981-87	18-7120	1	BS					
70	1988-95	18-7475	1	BS					
70	1988-95	18-7145	2	D&F S					
75	1960,63-65	18-7120	4	PBH S					
75	1961-65	18-7174	1	WT E					
75	⑤ 1964-65,75-88	18-7115	1	DS BH					
75	1965	18-7120	1	SR PP					
75	⑥ 1975-87	18-7127	1	PBH					
75 20" Transom	1975-87	18-7128	1	DS BH					
75 15" Transom	1975-88	18-7140	1	PBH					
75	1981-86	18-7120	1	BS					
75	1987-88	18-7475	1	BS					
75	1987-88	18-7145	2	D&F S					
V-4	1964-66,68-70	18-7120	4	PBH S					
V-4	1964-67	18-7174	1	WT E					
V-4	1964-68	18-7115	1	DS BH					
V-4	1964-72	18-7174	1	DS CC					

- ① 35 hp '87 Modelos RC, RL
 ② '62-'70 Sin cambio eléctrico/'89-'90 Comm.
 ③ '65 Caja engr. estándar/'75-'87 15" Transom
 ④ '76-'87 20" Transom
 ⑤ '77-'85 20" Transom
 ⑥ '79-'81 Arranque eléctrico
 ⑦ '79-'81 Arranque manual
 ⑧ '79-'81 Arranque manual/'82 Comm.
 ⑨ '79-'81 Arranque manual/'83-'90 Comm.
 ⑩ '80-'81 Arranque eléctrico/'86-'87 - 15" Transom
 ⑪ '80-'81 Arranque eléctrico/'86,'87 - 20" Transom
 ⑫ '87 Modelos AR, AE
 ⑬ '87 Modelos RC, RL
 ⑭ '89 Modelos DR, DE, DT
 ⑮ '89 WTLZ, WTXZ Modelos '90 WTESM, WTXESM Comm.
 ⑯ '89 WTLZ, WTXZ / '90 WTLES, WTESM Comm.
 ⑰ '89 WTPLY, WTALY, WTPXY, WTAXY, '90 WTPLA, WTALA, WTPXA/Comm.
 ⑱ AR, AE Modelos
 ☆ B, BR Modelos
 ⊕ también modelos comerciales
 ☆ Arranque eléctrico
 * Cambio eléctrico

- BS Juego de tornillos cojinete
 DS BH Eje transmisión a alojamiento cojinete
 DS CC Eje transmisión a alojamiento cigüeñal
 D & F S Tornillo llenado/vaciado
 WT E 5" Caja de engranajes extensión, Tubo de agua
 GC 1 Caja engranajes (11 7/16")
 GC 2 Caja engranajes (12 7/8")
 GC3 Caja engranajes (19 1/2")
 IH Alojamiento impulsor.
 IHS Espaciador alojamiento impulsor.
 PBH Alojamiento cojinete.
 PBH S tornillo alojamiento cojinete
 PS OP Eje hélice bomba aceite
 SA,L Pasador largo
 SA,S Pasador pequeño
 SR Varilla
 SR PP Pasador
 SR S Varilla
 WT Tubo agua

**JOHNSON**

POTENCIA HP	AÑO	NGK	Ref. PRONAUTIC	CHAMPION	Ref. PRONAUTIC
2.0 Excel 4, Ultra	1988-1987	B7HS	050806	UL81C	050988
2.0 Colt, Jr	1990-1971	BR6S	050734	RJ8C/J8C	050945/050903
2.0, 2R	1984-1971	BR6S	050734	RJ8C/J8C	050945/050903
2.0 1 CiL.	2001-1991	BPR6HS	050827	QL87YC/L87YC	050920/050920
2.3 1 CiL.	1998-1991	BPR6HS	050827	QL87YC/L87YC	050920/050920
2.5	1988-1987	BR6HS	050714	QL82C/L82C	050966/050937
3.0 2CiL.	1997-1989	BR6HS	050714	QL82C/L82C	050966/050937
3.3 1 CiL.	2003-1991	BPR6HS	050827	QL87YC/L87YC	050920/050920
4.0 Excel, Ultra	1988-1987	BZ7HS-10	050885	QL77JC4/L77JC4	050914/050906
4.0 2 CiL.	2003-1989	BR6HS	050714	QL82C/L82C	050966/050937
4.0	1988	BZ7HS-10	050885	QL77JC4/L77JC4	050914/050906
4.0	1987-1977	BR6HS	050714	QL82C/L82C	050966/050937
4.0	1984-1981	BZ7HS-10	050885	QL77JC4/L77JC4	050914/050906
4.0	1976-1969	BR6S	050734	RJ8C/J8C	050945/050903
4.5	1985-1980	BR6HS	050714	QL82C/L82C	050966/050937
5.0 Angler	1968-1965	BR6S	050734	RJ8C/J8C	050945/050903
4.0 4 Tiempos	2003-1997	D6HA	050603		
5.0 1 CiL.	2001-1998	BZ7HS-10	050885	QL77JC4/L77JC4	050914/050906
5.0	1997-1990	BR6HS	050714	QL82C/L82C	050966/050937
5.0 4T. OHC 128cc.	1997-2003	D6HA	050603		
6.0, 6R, 6RL	1976-1971	BR6S	050734	RJ8C/J8C	050945/050903
6.0 4T OHC 128cc.	2003-1997	D6HA	050603		
6.0, 2 Tiempos	2001-1977	BR6HS	050714	QL82C/L82C	050966/050937
6.0	1976-1965	BR6S	050734	RJ8C/J8C	050945/050903
6.5 COM	1993-1981	BR6HS	050714	QL82C/L82C	050966/050937
7.5	1997-1977	BR6HS	050714	QL82C/L82C	050966/050937
8.0 COM	2001-1977	BR6HS	050714	QL82C/L82C	050966/050937
8.0 4 T. 211 cc	2003-1996	D6HA	050603		
8.0 4T OHC 211cc.	2003-1996	D6HA	050603		
8.0, 2 Tiempos	2001-1977	BR6HS	050714	QL82C/L82C	050966/050937
9.9 4 T, OHC	2003-1995	DCPR7E	050894	RA8HC	050957
9.9, 2 T SOHC	2003-2002	DCPR7E	050894	RA8HC	050957
9.9, 2 T, OHC	2001-1977	BR7HS	050853	QL82C/L82C	050966/050937
9.9 4T OHC 211cc.	1998-1996	D6HA	050603		
10 COM	2003-1994	BR7HS	050853	QL82C/L82C	050966/050937
10 COM	1993-1992	BZ7HS-10	050885	QL77JC4/L77JC4	050914/050906
10 COM	1982-1981	BUHW-2	050840		
14 COM	1991-1981	BZ7HS-10	050885	QL77JC4/L77JC4	050914/050906
14	1989-1988	BZ7HS-10	050885	QL77JC4/L77JC4	050914/050906
15 Kero	1998-1995	BUHXW-1	050604	UL77V	050932
15 COM	2001-1994	BR7HS	050853	QL82C/L82C	050966/050937
15 COM	1993-1992	BZ7HS-10	050885	QL77JC4/L77JC4	050914/050906
15, 4 T, OHC	2003-1995	DCPR7E	050894	RA8HC	050957
15, 2 T	2001-1994	BR7HS	050853	QL82C/L82C	050966/050937
15	1992-1977	BZ7HS-10	050885	QL77JC4/L77JC4	050914/050906
15	1980-1978	BUHW-2	050840		
15	1976-1974	B7HS	050806	UL81C	050988

Bujías
JOHNSON / EVINRUDE

**JOHNSON**

POTENCIA HP	AÑO	NGK	Ref. PRONAUTIC	CHAMPION	Ref. PRONAUTIC
15	1971-1956	BR6S	050734	RJ8C/J8C	050945/050903
18 Jet 2 Cil.	1998-1995	BR7HS	050853	QL82C/L82C	050966/050937
20 Jet 2 Cil.	2001-1999	BR7HS	050853	QL82C/L82C	050966/050937
20, 2 Cil.	1998-1978	BR7HS	050853	QL82C/L82C	050966/050937
20	1993-1978	BR7HS	050853	QL82C/L82C	050966/050937
25 COM	2002-1981	BUHXW-1	050604	UL77V	050932
25, 3 Cil.	2001-1995	BR6HS	050714	QL82C/L82C	050966/050937
25, E,EL,R,RL	1976-1973	BR6S	050734	RJ8C/J8C	050945/050903
25, 2 Cil.	2002-1977	BR7HS	050853	QL82C/L82C	050966/050937
25	1976-1969	BR6S	050734	RJ8C/J8C	050945/050903
28, SPL, 2 Cil.	1997-1978	BR7HS	050853	QL82C/L82C	050966/050937
28 Jet	2003-1992	BPZ8HS-10	050842	QL78YC/L78YC	050917/050933
30 Jet 2 Cil.	2001-1999	BPR7HS	050829	QL78YC/L78YC	050917/050933
30, 4 T, OHC	2003-1995	DCPR7E	050894	RA8HC	050957
30, 2 Cil.	2002-1978	BR7HS	050853	QL82C/L82C	050966/050937
35 Jet 2 Cil.	2003-1993	BPZ8HS-10	050842	QL78YC/L78YC	050917/050933
35, 3 Cil.	2001-1995	BR7HS	050853		
35, 2 Cil.	1997-1977	BZ7HS-10	050885	QL77JC4/L77JC4	050914/050906
40 Jet 3 Cil.	2001-1999	BR7HS	050853	QL82C/L82C	050966/050937
40 COM 45 cid	2003-1984	BUHXW-1	050604	UL77V	050932
40 COM 43 cid	1990-1981	BR7HS	050853	QL82C/L82C	050966/050937
40, E,EL,R,RL	1976-1975	BZ7HS-10	050885	QL77JC4/L77JC4	050914/050906
40, 4 T, DOHC	2003-2002	DCPR7E	050894	RA8HC	050957
40, 2 Cil.	2002-1989	BPZ8HS-10	050842	QL78YC/L78YC	050917/050933
40, 2 Cil.	1988-1980	BZ7HS-10	050885	QL77JC4/L77JC4	050914/050906
45 COM	2002-1984	BUHXW-1	050604	UL77V	050932
48, SPL 2 Cil.	1997-1994	BPZ8HS-10	050842	QL78YC/L78YC	050917/050933
48, 2 Cil.	1997-1989	BPZ8HS-10	050842	QL78YC/L78YC	050917/050933
48,2 Cil.	1988-1980	BZ7HS-10	050885	QL77JC4/L77JC4	050914/050906
50,3 Cil.	1998-1995	BPZ8HS-10	050842	QL78YC/L78YC	050917/050933
50,2 Cil.	2002-1989	BPZ8HS-10	050842	QL78YC/L78YC	050917/050933
50,2 Cil.	1988-1980	BZ7HS-10	050885	QL77JC4/L77JC4	050914/050906
55 COM,2 Cil.	1995-1994	BPZ8HS-10	050842	QL78YC/L78YC	050917/050933
55 COM	2003-1986	BUHXW-1	050604	UL77V	050932
55,2 Cil.	1989-1976	B7HS	050806	UL81C	050988
60,4 T,OHC	2005-2002	BPR6ES	050826		
60,3 Cil.,56 cid	1998-1994	BPZ8HS-10	050842	QL78YC/L78YC	050917/050933
60,3 Cil.,56 cid	1993-1989	BZ7HS-10	050885	QL77JC4/L77JC4	050914/050906
60,3 Cil.,49 cid	1989-1975	BZ7HS-10	050885	QL77JC4/L77JC4	050914/050906
60,2 Cil.	1985-1980	BZ7HS-10	050885	QL77JC4/L77JC4	050914/050906
65 COM,3 Cil.	1995-1994	BPZ8HS-10	050842	QL78YC/L78YC	050917/050933
65 COM HC LC	2003-1988	BUHXW-1	050604	UL77V	050932
65 COM HC LC	1987-1984	BZ7HS-10	050885	QL77JC4/L77JC4	050914/050906
65 Jet CV4	1997-1992	BR7HS	050853	QL82C/L82C	050966/050937
65,3 Cil.	1973-1972	BZ7HS-10	050885	QL77JC4/L77JC4	050914/050906
70,3 Cil.,56 cid	2001-1997	BPZ8HS-10	050842	QL78YC/L78YC	050917/050933
70,3 Cil.,56 cid	1993-1989	BZ7HS-10	050885	QL77JC4/L77JC4	050914/050906

**JOHNSON**

POTENCIA HP	AÑO	NGK	Ref. PRONAUTIC	CHAMPION	Ref. PRONAUTIC
70,3 Cil.,49 cid	1989-1975	BZ7HS-10	O50885	QL77JC4/L77JC4	O50914/O50906
75,3 Cil.,49 cid	1989-1975	BZ7HS-10	O50885	QL77JC4/L77JC4	O50914/O50906
80 Jet CV4	2001-1979	BR7HS	O50853	QL82C/L82C	O50966/O50937
85,V4 Backtroller	1995-1994	BR7HS	O50853	QL82C/L82C	O50966/O50937
85	1993-1986	BZ7HS-10	O50885	QL77JC4/L77JC4	O50914/O50906
85	1980-1968	B7HS	O50806	UL81C	O50988
88 CV4 SPL	1997-1979	BR7HS	O50853	QL82C/L82C	O50966/O50937
90 Turbojet CV4	1998-1994	BR7HS	O50853	QL82C/L82C	O50966/O50937
90 LV4 FFI	1998	PZFR6H	O50886	XC12PEPB	
90 LV4	2000-1995	BPZ8HS-10	O50842	QL78YC/L78YC	O50917/O50933
90 CV4	1998-1979	BR7HS	O50853	QL82C/L82C	O50966/O50937
100 V4	1980-1979	B7HS	O50806	UL81C	O50988
100 COM	2001-1984	BUHXW-1	O50604	UL77V	O50932
105 COM LV4	2003-1997	BPZ8HS-10	O50842	QL78YC/L78YC	O50917/O50933
105 LV6 105 Jet	2003-1993	BPZ8HS-10	O50842	QL78YC/L78YC	O50917/O50933
110 CV4	1997-1979	BR7HS	O50853	QL82C/L82C	O50966/O50937
112 CV4	1997-1979	BR7HS	O50853	QL82C/L82C	O50966/O50937
115 Turbojet CV4	1998-1994	B7HS	O50806	UL81C	O50988
115 LV4 FFI	1998	PZFR6H	O50886	XC12PEPB	
115 Fast Stike LV4	2002-1995	BPZ8HS-10	O50842	QL78YC/L78YC	O50917/O50933
115 CV4	1998-1979	BR7HS	O50853	QL82C/L82C	O50966/O50937
115 COM	1984-1975	B7HS	O50806	UL81C	O50988
115	1993-1986	BZ7HS-10	O50885	QL77JC4/L77JC4	O50914/O50906
115	1979-1973	BZ7HS-10	O50885	QL77JC4/L77JC4	O50914/O50906
115	1985	BUHXW-1	O50604	UL77V	O50932
120 LV4	2003-1985	BPZ8HS-10	O50842	QL78YC/L78YC	O50917/O50933
125 COM	1972-1971	B7HS	O50806	UL81C	O50988
130 LV4	2003-1985	BPZ8HS-10	O50842	QL78YC/L78YC	O50917/O50933
135 Starflite	1984-1973	BUHXW-1	O50604	UL77V	O50932
140 LV4	2003-1985	BPZ8HS-10	O50842	QL78YC/L78YC	O50917/O50933
140	1984-1973	BUHXW-1	O50604	UL77V	O50932
150 LV6 FFI	1998-1997	PZFR6H	O50886	XC12PEPB	
150 Fast Strike LV6	2002-1991	BPZ8HS-10	O50842	QL78YC/L78YC	O50917/O50933
150 CV6	1991-1988	BZ7HS-10	O50885	QL77JC4/L77JC4	O50914/O50906
150 CV6	1987-1978	BUHXW-1	O50604	UL77V	O50932
150 COM LV6	1998-1993	BPZ8HS-10	O50842	QL78YC/L78YC	O50917/O50933
155 CV6	1987-1978	BUZ8H	O50735	QL16V	O50911
155 COM CV6	1992-1989	BUZ8H	O50735	QL16V	O50911
175 LV6 FFI	1998	PZFR6H	O50886	XC12PEPB	
175 Fast Strike LV6	2002-1991	BPZ8HS-10	O50842	QL78YC/L78YC	O50917/O50933
175 CV6	1991-1988	BZ7HS-10	O50885	QL77JC4/L77JC4	O50914/O50906
175	1987-1977	BUHXW-1	O50604	UL77V	O50932
185	1987-1977	BUZ8H	O50735	QL16V	O50911
185	1993-1990	BZ7HS-10	O50885	QL77JC4/L77JC4	O50914/O50906
200	1983-1976	BUZ8H	O50735	QL16V	O50911
200 COM	1992	BUZ8H	O50735	QL16V	O50911
200 COM	1998-1993	BPZ8HS-10	O50842	QL78YC/L78YC	O50917/O50933



JOHNSON



POTENCIA HP	AÑO	NGK	Ref. PRONAUTIC	CHAMPION	Ref. PRONAUTIC
200 V6	1993-1986	BZ7HS-10	O50842	QL77JC4/L77JC4	O50914/O50906
200 Venom LV6	2003-1994	BPZ8HS-10	O50842	QL78YC/L78YC	O50917/O50933
225 V6	1993-1986	BZ7HS-10	O50885	QL77JC4/L77JC4	O50914/O50906
225 Venom LV6	2003-1994	BPZ8HS-10	O50842	QL78YC/L78YC	O50917/O50933
235	1985-1978	BUHXW-1	O50604	QL16V	O50911
250 LV6	2001-1999	BUHXW-1	O50604	QL16V	O50911
250 V8	1997-1985	BPZ8HS-10	O50842	QL78YC/L78YC	O50917/O50933
275	1988-1985	BPR7HS	O50829	QL78YC/L78YC	O50917/O50933
300 V8	1997-1985	BPZ8HS-10	O50842	QL78YC/L78YC	O50917/O50933



EVINRUDE



POTENCIA HP	AÑO	NGK	Ref. PRONAUTIC	CHAMPION	Ref. PRONAUTIC
1.2 Magneto	1990-1986	BR6S	O50734	RJ8C/J8C	O50945/O50903
2.0 Jr. Colt	1990-1971	BR6S	O50734	RJ8C/J8C	O50945/O50903
2.0, 2R	1984-1971	BR6S	O50734	RJ8C/J8C	O50945/O50903
2.0, 1 CiL.	1998-1991	BPR6HS	O50827	QL87YC/L87YC	O50920/O50938
2.3	1997-1991	BPR6HS	O50827	QL87YC/L87YC	O50920/O50938
2.5	1988-1987	BZ7HS-10	O50842	QL77JC4/L77JC4	O50914/O50906
3.0, 2 CiL.	1997-1989	BR6HS	O50714	QL82C/L82C	O50966/O50937
3.3, 1 CiL.	2003-1991	BPR6HS	O50827	QL87YC/L87YC	O50920/O50938
3.4-4.0 Yachtwin	1974-1964	BR6S	O50734	RJ8C/J8C	O50945/O50903
4.0,Ultra,Excel	1988-1987	BZ7HS-10	O50885	QL77JC4/L77JC4	O50914/O50906
4.0,4R,4W	1976-1969	BR6S	O50734	RJ8C/J8C	O50945/O50903
4.0,2 CiL.	1998-1989	BR6HS	O50714	QL82C/L82C	O50966/O50937
4.0	1987-1977	BR6HS	O50714	QL82C/L82C	O50966/O50937
4.0	1984-1981	BZ7HS-10	O50842	QL77JC4/L77JC4	O50914/O50906
4.5	1985-1980	BR6HS	O50714	QL82C/L82C	O50966/O50937
5.0,4 T,OHC 128cc	2008-1997	DR5HS	O50852		
5.0	1998	BR6HS	O50714	QL82C/L82C	O50966/O50937
5.0	1997-1990	BR6HS	O50714	QL82C/L82C	O50966/O50937
5.0, 4 T	2008-1997	D6HA			
6.0,6R,6RL	1976-1971	BR6S	O50734	RJ8C/J8C	O50945/O50903
6.0,4T,OHC 128cc	2008-1997	DR5HS	O50852		
6.0,2T	1998-1977	BR6HS	O50714	QL82C/L82C	O50966/O50937
6.0	1976-1965	BR6S	O50734	RJ8C/J8C	O50945/O50903
6.0, 4T	2008-1997	D6HA			
6.5 COM	1993-1981	BR6HS	O50714	QL82C/L82C	O50966/O50937
7.5	1997-1977	BR6HS	O50714	QL82C/L82C	O50966/O50937
8.0 COM	1998-1977	BR6HS	O50714	QL82C/L82C	O50966/O50937
8.0 4T. OHC 211cc	2008-1996	DR5HS	O50852		
8.0,2T	1998-1977	BR6HS	O50714	QL82C/L82C	O50966/O50937
8.0, 4T	1997-1995	D6HA			
9.9, 4T,OHC 305cc	2008-1998	DCPR7E	O50894	RA8HC	O50957
9.9,4T,OHC 302cc	1997-1995	DCPR7E	O50894	RA8HC	O50957
9.9,4T,211cc	1997-1996	D6HA			



EVINRUDE



POTENCIA HP	AÑO	NGK	Ref. PRONAUTIC	CHAMPION	Ref. PRONAUTIC
9.9, 2T	2001-1977	BR7HS	O50853	QL82C/L82C	O50966/O50937
9.9	1976-1974	B7HS	O50806	UL81C	O50988
10 COM	2003-1994	BR7HS	O50853	QL82C/L82C	O50966/O50937
10 COM	1993-1992	BZ7HS-10	O50842	QL77JC4/L77JC4	O50914/O50906
10R,10RL,10E,10EL	1976-1975	BZ7HS-10	O50842	QL77JC4/L77JC4	O50914/O50906
14 COM	1991-1981	BZ7HS-10	O50842	QL77JC4/L77JC4	O50914/O50906
14	1989-1988	BZ7HS-10	O50842	QL77JC4/L77JC4	O50914/O50906
15 Kero	1998-1995	BUHXW-1	O50604	UL77V	O50932
15 COM	2001-1994	BR7HS	O50853	QL82C/L82C	O50966/O50937
15 COM	1993-1992	BZ7HS-10	O50842	QL77JC4/L77JC4	O50914/O50906
15,4 T,OHC 305cc	2003-1995	DCPR7E	O50894	RA8HC	O50957
15, 2T	1998-1994	BR7HS	O50853	QL82C/L82C	O50966/O50937
15E,15EL,15R,15RL	1976-1974	BZ7HS-10	O50842	QL77JC4/L77JC4	O50914/O50906
15	1992-1977	BZ7HS-10	O50842	QL77JC4/L77JC4	O50914/O50906
15	1976-1974	B7HS	O50806	UL81C	O50988
18 Jet 2 CiL.	1998-1995	BR7HS	O50853	QL82C/L82C	O50966/O50937
18 Fastwin	1973-1957	BR6S	O50734	RJ8C/J8C	O50945/O50903
18	1973-1957	BR6S	O50734	RJ8C/J8C	O50945/O50903
18	1972-1950	BR6S	O50734	RJ8C/J8C	O50945/O50903
20,2 CiL.	1998-1978	BR7HS	O50853	QL82C/L82C	O50966/O50937
20	1993-1978	BR7HS	O50853	QL82C/L82C	O50966/O50937
25,Evinrude 25	1993-1978	BZ7HS-10	O50842	QL77JC4/L77JC4	O50914/O50906
25 COM	1998-1981	BUHXW-1	O50604	UL77V	O50932
25,3 CiL.	1998-1995	BR6HS	O50714	QL82C/L82C	O50966/O50937
25R,25RL	1976-1973	BR6S	O50734	RJ8C/J8C	O50945/O50903
25E,25EL	1976-1973	BR6S	O50734	RJ8C/J8C	O50945/O50903
25,2 CiL	1998-1977	BR7HS	O50853	QL82C/L82C	O50966/O50937
25	1977	BR7HS	O50853	QL82C/L82C	O50966/O50937
25	1976-1969	BR6S	O50734	RJ8C/J8C	O50945/O50903
25, 4 T	2001-2000	DCPR7E	O50894		
28 Jet	2003-1992	BPZ8HS-10	O50842	QL78YC/L78YC	O50917/O50933
28,2 CiL.	1997-1978	BR7HS	O50853	QL82C/L82C	O50966/O50937
30, 4 T	2003-2000	DCPR7E	O50894	RA8HC	O50957
30,2 CiL.	1998-1978	BR7HS	O50853	QL82C/L82C	O50966/O50937
30,4 T OHC	2003-1995	DCPR7E	O50894		
35 Jet,2 CiL.	2001-1993	BPZ8HS-10	O50842	QL78YC/L78YC	O50917/O50933
35,3 CiL.	2001-1995	BR6HS	O50714	QL82C/L82C	O50966/O50937
35,2 CiL.	1997-1977	BZ7HS-10	O50885	QL77JC4/L77JC4	O50914/O50906
35	1976	BZ7HS-10	O50885	QL77JC4/L77JC4	O50914/O50906
40 COM45 cid	2003-1984	BUHXW-1	O50604	UL77V	O50932
40 COM43 cid	1990-1981	B7HS	O50806	UL81C	O50988
40,4T DOHC 815cc	2008-1999	DCPR7E	O50894	RA8HC	O50957
40,2 CiL.	1998-1989	BPZ8HS-10	O50842	QL78YC/L78YC	O50917/O50933
40,E-TEC	2005-2004	PZFR6H	O50886		
40,2 CiL.	1988-1980	BZ7HS-10	O50842	QL77JC4/L77JC4	O50914/O50906
40	1976-1974	B7HS	O50806	UL81C	O50988
40,4T DOHC	2003-2002	DCPR7E	O50894		

**EVINRUDE**

POTENCIA HP	AÑO	NGK	Ref. PRONAUTIC	CHAMPION	Ref. PRONAUTIC
45 COM	2003-1991	BUHXW-1	O50604	UL77V	O50932
45 COM	1990-1986	BUZHW-2			
48 SPL 2 CiL.	1997-1994	BPZ8HS-10	O50842	QL78YC/L78YC	O50917/O50933
48,2 CiL.	1997-1989	BPZ8HS-10	O50842	QL78YC/L78YC	O50917/O50933
48,2 CiL.	1998-1990	BZ7HS-10	O50885	QL77JC4/L77JC4	O50914/O50906
50,4T,DOHC 815cc	2008-1999	DCPR7E	O50894	RA8HC	O50957
50, 3 CiL.	1998-1995	BPZ8HS-10	O50842	QL78YC/L78YC	O50917/O50933
50, 2 CiL.	2002-1989	BPZ8HS-10	O50842	QL78YC/L78YC	O50917/O50933
50, 2 CiL.	1988-1980	BZ7HS-10	O50885	QL77JC4/L77JC4	O50914/O50906
50	1979-1978	B7HS	O50806	UL81C	O50988
50 E-TEC	2005-2004	PZFR6H	O50886		
55 COM,2 CiL.	1995-1994	BPZ8HS-10	O50842	QL78YC/L78YC	O50917/O50933
55 COM	2003-1986	BUHXW-1	O50604	UL77V	O50932
55,2 CiL.	1989-1976	B7HS	O50806	UL81C	O50988
60,4 T,OHC	2008-2002	BPR6ES	O50826		
60,3 CiL. 56 cid	1998-1994	BPZ8HS-10	O50842	QL78YC/L78YC	O50917/O50933
60,3 CiL. 56 cid	1993-1989	BZ7HS-10	O50885	QL77JC4/L77JC4	O50914/O50906
60,3 CiL. 49 cid	1989-1975	BZ7HS-10	O50885	QL77JC4/L77JC4	O50914/O50906
60,2 CiL.	1985-1980	BZ7HS-10	O50885	QL77JC4/L77JC4	O50914/O50906
60 E-TEC	2005-2004	PZFR6H	O50886		
65,CV4 65 Jet	1997-1992	BR7HS	O50853	QL82C/L82C	O50966/O50937
65 COM,3 CiL.	1995-1994	BPZ8HS-10	O50842	QL78YC/L78YC	O50917/O50933
65 COM HOLO	1997-1988	BUHXW-1	O50604	UL77V	O50932
65 COM HOLO	1987-1984	BZ7HS-10	O50885	QL77JC4/L77JC4	O50914/O50906
70,4T OHC 298cc	2003-1998	BPR6ES	O50826		
70,3 CiL. 56 cid	1998-1994	BPZ8HS-10	O50842	QL78YC/L78YC	O50917/O50933
70,3 CiL. 56 cid	1993-1989	BZ7HS-10	O50885	QL77JC4/L77JC4	O50914/O50906
70,3 CiL. 49 cid	1989-1975	BZ7HS-10	O50885	QL77JC4/L77JC4	O50914/O50906
75,3 CiL. 49 cid	1989-1975	BZ7HS-10	O50885	QL77JC4/L77JC4	O50914/O50906
75 E-TEC	2005-2004	PZFR6H	O50886		
80 Jet CV4	1998-1979	BR7HS	O50853	QL82C/L82C	O50966/O50937
85,V4 Backtroller	1995-1994	BR7HS	O50853	QL82C/L82C	O50966/O50937
85	1993-1986	BZ7HS-10	O50885	QL77JC4/L77JC4	O50914/O50906
85	1980-1968	B7HS	O50806	UL81C	O50988
88 CV4 SPL	1997-1979	BR7HS	O50853	QL82C/L82C	O50966/O50937
90 E-TEC 1.3L	2008-2007	BZFRN-E			
90 Turbojet CV4	1997-1994	BR7HS	O50853	QL82C/L82C	O50966/O50937
90 LV4 FFI	1998-2000	PZFR6H	O50886	XC12PEPB	
90 LV4	1998-1995	BPZ8HS-10	O50842	QL78YC/L78YC	O50917/O50933
90 CV4	1998-1979	BR7HS	O50853	QL82C/L82C	O50966/O50937
90 E-TEC	2005-2004	PZFR6H	O50886		
100 V4	1980-1979	B7HS	O50806	UL81C	O50988
100 COM	1998-1984	BUHXW-1	O50604	UL77V	O50932
105 COM LV4	2003-1997	BPZ8HS-10	O50842	QL78YC/L78YC	O50917/O50933
105 LV6 105 Jet	2003-1993	BPZ8HS-10	O50842	QL78YC/L78YC	O50917/O50933
110 CV4	1997-1979	BR7HS	O50853	QL82C/L82C	O50966/O50937
112 CV4	1997-1979	BR7HS	O5085	QL82C/L82C	O50966/O50937











EVINRUDE



POTENCIA HP	AÑO	NGK	Ref. PRONAUTIC	CHAMPION	Ref. PRONAUTIC
115 Turbojet CV4	1998-1994	B7HS	O50806	UL81C	O50988
115 LV4 FFI	2003-1998	PZFR6H	O50886	XC12PEPB	
115 Intruder LV4	1998-1995	BPZ8HS-10	O50842	QL78YC/L78YC	O50917/O50933
115 CV4	1998-1979	BR7HS	O50853	QL82C/L82C	O50966/O50937
115 COM	1984-1975	B7HS	O50806	UL81C	O50988
115	1993-1986	BZ7HS-10	O50885	QL77JC4/L77JC4	O50914/O50906
115	1979-1973	BZ7HS-10	O50885	QL77JC4/L77JC4	O50914/O50906
115	1985	BUHXW-1	O50604	UL77V	O50932
115 E-TEC 1.7L V4	2008-2007	BZFR6N-E			
120 LV4	2003-1985	BPZ8HS-10	O50842	QL78YC/L78YC	O50917/O50933
125 COM	1972-1971	B7HS	O50806	UL81C	O50988
130 LV4	2003-1985	BPZ8HS-10	O50842	QL78YC/L78YC	O50917/O50933
135	1984-1973	BUHXW-1	O50604	UL77V	O50932
140 LV4	2003-1985	BPZ8HS-10	O50842	QL78YC/L78YC	O50917/O50933
140	1984-1973	BUHXW-1	O50604	UL77V	O50932
150 LV6 FFI	1998-1997	PZFR6H	O50886	XC12PEPB	
150 Intruder LV6	1998-1991	BPZ8HS-10	O50842	QL78YC/L78YC	O50917/O50933
150 CV6	1991-1988	BZ7HS-10	O50885	QL77JC4/L77JC4	O50914/O50906
150 CV6	1987-1978	BUHXW-1	O50604	UL77V	O50932
150 COM LV6	1998-1993	BPZ8HS-10	O50842	QL78YC/L78YC	O50917/O50933
155 CV6	1987-1978	BUHXW-1	O50604	UL77V	O50932
155 COM CV6	1992-1989	BUHXW-1	O50604	UL77V	O50932
175 LV6 FFI	1998	PZFR6H	O50886	XC12PEPB	
175 Intruder LV6	1998-1991	BPZ8HS-10	O50842	QL78YC/L78YC	O50917/O50933
175 CV6	1991-1988	BZ7HS-10	O50885	QL77JC4/L77JC4	O50914/O50906
175	1987-1977	BUHXW-1	O50604	UL77V	O50932
185	1987-1977	BUZ8H		QL16V	O50911
185 COM	1993-1990	BZ7HS-10	O50885	QL77JC4/L77JC4	O50914/O50906
200 Vindicator L	1998-1994	BPZ8HS-10	O50842	QL78YC/L78YC	O50917/O50933
200 V6	1993-1986	BZ7HS-10	O50885	QL77JC4/L77JC4	O50914/O50906
200 LV6 FFI	2004-1999	PZFR6H	O50886	XC12PEPB	
200 COM	1998-1993	BPZ8HS-10	O50842	QL78YC/L78YC	O50917/O50933
200 COM	1992	BUHXW-1	O50604	UL77V	O50932
200	1983-1976	BUHXW-1	O50604	UL77V	O50932
225 Vindicator	1998-1994	BPZ8HS-10	O50842	QL78YC/L78YC	O50917/O50933
225 LV6 FFI	2004-1999	PZFR6H	O50886	XC12PEPB	
225	1993-1986	BZ7HS-10	O50885	QL77JC4/L77JC4	O50914/O50906
235	1985-1978	BUHXW-1	O50604	UL77V	O50932
250 V8	1997-1985	BPZ8HS-10	O50842	QL78YC/L78YC	O50917/O50933
175	1988-1985	BPZ8HS-10	O50842	QL78YC/L78YC	O50917/O50933
300 V8	1997-1985	BPZ8HS-10	O50842	QL78YC/L78YC	O50917/O50933

EVINRUDE / JOHNSON / O.M.C.

Tipo	Modelo Fueraborda	Referencia-Diam./Paso	Ref. Original	Pala	Núcleo
A	 <p>8 - 15 hp 2-1/2" Caja de engranajes</p> <ul style="list-style-type: none"> • 8 hp (4 tiempos) 1996-2005 • 9.9 y 15hp (2 tiempos) 1974-2005 • 9.9 y 15hp (4 tiempos) 1995-2001 <p>Escape a través del núcleo, 13 estrias</p>	62J1591210 9 1/2x10	778772	3	Fijo
		62J251013 10x13	778863	3	Fijo
B	 <p>15 - 35 hp 3" Caja de engranajes</p> <ul style="list-style-type: none"> • 15hp E-TEC H.O 2011 y posteriores • 20hp (2 cilindros) 1984-1997 • 25hp (2 y 3 cilindros) 1984 y post. • 25, 30hp (E-TEC) 2009 y post. • 30hp (2 cilindros) 1984 y post. • 35hp (2 cilindros) 1979-1983 • 35hp (3 cilindros) 1997-2001 <p>Escape a través del núcleo, 14 estrias</p>	62J251015 10x15	763486	3	Fijo
		62U4012149 12 1/4x9		3	Interc. 62BHSJC
C	 <p>40 - 50 hp 3-1/4" Caja de engranajes</p> <ul style="list-style-type: none"> • 40hp (4 tiempos) 1999-2005 • 50hp (4 tiempos) 1999-2005 <p>Escape a través del núcleo, 13 estrias</p>	62U40113410 11 3/4x10		3	
		62U40115811 11 5/8x11		3	
		62U40113812 11 3/8x12		3	
		62U40111813 11 1/8x13		3	
		62U40111414 11 1/4x14		3	
		624U40105812 10 5/8x12	48-8M8026625	4	
		624U40103813 10 3/8x13	48-8M8026630	4	
		624U40101814 10 1/8x14	48-8M8026635	4	
		624U40101815 10 1/8x15	48-8M8026640	4	
			 <p>40 - 75 hp 3-3/8" Caja de engranajes</p> <ul style="list-style-type: none"> • 40hp (2 cilindros) 1984-2005 • 48hp 1987-1996 • 50hp (2 cilindros) 1975-2005 • 55hp 1976-1979 • 65hp (2 cilindros) 1980-1985 • 75hp (3 cilindros) 1975-1985 • Sprint / Formula E 1986-1992 <p>Escape a través del núcleo, 13 estrias</p>	62J48121213 12 1/2x13	763461
62J48121415 12 1/4x15	778774			3	Fijo
62U48121213 12 1/2x13				3	Interc. 62BHJC48
62U48121415 12 1/4x15				3	

Tipo	Modelo Fueraborda	Referencia -Diam./Paso	Ref. original	Palas	Núcleo
D	 <p>45-140 hp 4-1/4" Caja de engran. 2 tiempos motores Fueraborda: • 40hp (E-Tec)2004 y posteriores • 45hp (2cil. comercial) 1986y post. • 50hp (E-Tec) 2004 y posteriores • 50hp (2cil. comercial) 1977-1979 • 50hp (2cil.) 1971-1974 • 50hp (3cil.) 1994 y posteriores • 55hp (2cil. comercial) 1980y post. • 55hp (3cil.) 1968-1969 • 60hp (3cil.) 1970-71, 1986 y post. • 60hp (E-Tec) 2004 y posteriores • 65hp (3cil. comercial) 1984y post. • 65hp (3cil.) 1972-1973 • 70hp (3cil.) 1974 y posteriores • 75hp (3cil.) 1975-1984 • 75hp (E-Tec) 2004 y posteriores 4 tiempos motores Fueraborda: • 60hp 1998 y posteriores • 70hp 1998y posteriores • 90hp 2003 y posteriores • 115hp 2003 y posteriores • 140hp 2003 y posteriores Escape a través del núcleo, 13 estrias</p>	62J701413 14x13	391668	3	Fijo
		62J70133415 13 3/4x15	391198	3	
		62J70131417 13 1/4x17	763463	3	
		62J701417 14x17	176214	3	
		62J70131419 13 1/4x19	763464	3	
		62J150151213 15 1/2x13	763453	3	
E	   <p>90 - 300 hp 4-3/4" Caja de engranajes 2 tiempos Motores Fueraborda: • 90hp 1995 y posteriores • 90hp (E-Tec extra long) 2004y post. • 100hp (comercial) 1984 y post. • 115hp 1995 y posteriores • 120-140hp 1985 • 130hp 1995 y posteriores • 140hp (25") 1989-1994 • 150hp (comercial) 1993 y post. • 150hp 1978 y posteriores • 155hp (comercial) 1978 y post. Transmisiones :Model800, Cobra y King Cobra : • 3.0 L - 8.2 L (no SX colas) 1990-1993 • Cobra 5.8 L 1990-1993 • SeaDrive2.0-4.0L todos los años Escape a través del núcleo, 15 estrias</p>	62J150151215 15 1/2x15	391535	3	
		62J1501517 15x17	391200	3	
		62U150151415 15 1/4x15	48-78116A45	3	
		62U1351517 15x17	48-832828A45	3	
		62U150141219 14 1/2x19	48-832830A45	3	
		62U150141421 14 1/4x21	48-832832A45	3	
		62U1501423 14x23	48-832834A45	3	
		624U1501516 15x16	48-834850A45	4	
		624U150141218 14 1/2x18	48-834852A45	4	
624U1501420 14x20	48-834854A45	4	Interc. 62BHJE		



SHIELDS MARINE HOSE



HIGH STANDARDS MEANS QUALITY ASSURED.

Shields Marine's complete range of hose solutions and accessories are designed to meet the demanding requirements of the marine environment.



Modelo Descripción	HP	Trim & Tilt/ Sistema de arranque	Longitud eje	Tipo de mando	Año Modelo	Modelo especial Código Variac. (Usado motores 25 HP)
B = Inshore series C = Serie C CV = Serie C D = hélice doble rotación DX = hélice doble rotación OX66 EFI E = Serie enduro F = 4 tiempos LF = 4 tiempos mano izquierda L = Mano izquierda LX = Mano izquierda OX66 EFI LZ = Mano izquierda HPDI P = Serie Pro PX = Serie Pro OX66 EFI S = Serie Agua salada SX = Serie agua salada OX66 EFI T = Cuatro tiempos de alto voltaje V = Serie V max VX = V max OX66 EFI VZ = V max HPDI Z = Serie HPDI	Ejemplo: 6 9.9 200 250	T = tilt o trim/tilt (1984-1990) P = eléctrico E = Arranque eléctrico (1984-1990) M = Tilt manual con Arranque manual	S = 15" L = 20" tilt con arranque U = 30"	R = Control Remoto H = Mando popero X = 25"	N = 1984 K = 1985 J = Jet H = 1987 G = 1988 F = 1989 D = 1990 P = 1991 Q = 1992 R = 1993 S = 1994 T = 1995 U = 1996 V = 1997 W = 1998 X = 1999 Y = 2000 Z = 2001 A = 2002 B = 2003 C = 2004 D = 2005	2 = 3 Cil. 1997 3 = 3 Cil. J = 1986

Desde abril de 2005 (2006 Modelo año) Yamaha no detalla el año de fabricación del motor al final de su referencia.

Desde entonces los nuevos modelos tienen una letra entre el control/tilt Método.

Ejemplo:

VZ300TLRD = 2005 VZ300TLR = Nuevo modelo desde abril de 2005. VZ300BTLR = Modelos más nuevos.

EJEMPLO: SX150TLRY - Agua salada EFI, 150 HP, Trim & Tilt con arranque eléctrico, 20", Control remoto, modelo 2000



**18-5130
CDI**

Reemplaza: 688-85540-16-00
 Para: 90(1988-91), C75(1994-96), C85(1991-96),
 CV85(1989-90), E75(1995-96)



**18-5131
CDI**

Reemplaza: 695-85540-11,
 695-85540-12-00
 Para: 9.9(1984-95), 15(1984-95), C25(1992-97),
 CV25(1990)



**18-5132
CDI**

Reemplaza: 63V-85540-00-00,
 63V-85540-01-00, 63V-85540-02-00
 Para: 9.9(1999-09), 15(1999-09)



**18-5110
BOBINA ENCENDIDO**

Reemplaza: 6E5-85570-11-00
 Para: 115 (4 cil.) 1985-91



**18-5111
BOBINA ENCENDIDO**

Reemplaza: 697-85570-11-00
 Para: 55 (2 cil.) 1989-94 y 90 1984-88



18-5112
BOBINA ENCENDIDO
Reemplaza: 6E7-85570-19-00,
680-85570-09-00,
6E7-85570-10-00, 695-85570-10-00
Para: 9.9/15 (1988-93)



18-5128
BOBINA ENCENDIDO
Reemplaza: 6R3-85570-01-00
Para: 115/130/150HP (1994-04) 175HP
(1994-95, 1997-98, 2000) 200HP (1994-98) 225HP (1997)
B115HP 1998-99) C115HP (1997-98) últimos modelos
V4 & V6



18-5183
BOBINA, CARGA
Reemplaza: 63V-85520-00,
63V-85520-01
Para: 9.9(1996-09), 15(1996-09)



18-5195
BOBINA, ENCENDIDO
Reemplaza: 689-81311-40-00
Para: 25(1984-87), 30(1984-86), C30(1991-92),
C40(1994-97), CV30(1989-90), CV40(1990)



18-5138
BOBINA, ENCENDIDO
Reemplaza: 680-85570-00-00; 680-85570-02-00
Para: T6 (02-05); F6, F8 (01-05); C25 (96-97)



18-5113
BOBINA, ENCENDIDO
Reemplaza: 61N-85570-00-00, 61N-85570-10-00
Para: 25(1994-95, 2001-09)



18-25650
BOBINA, PULSADOR
Reemplaza: 66M-85580-00-00
Para: F9.9(2005-06), T9.9(2005-06),
F15(1998-06)



18-25652
BOBINA, PULSADOR
Reemplaza: 63V-85580-01-00
Para: 9.9(2003-09), 15(2003-09)



18-25604
BOBINA LUZ
Reemplaza: 63V-85533-00-00
Para: 9.9(1996-09), 15(1996-09)



18-5135
CDI
Reemplaza: 6E5-85540-10-00,
6E5-85540-11-00, 6E5-85540-12-00
Para: 115 ET 1984-1989; 130 ET 1988-1989; C115TLR
1991-1996; C115TXR 1992-1996; L130ETX 1989; 1989
2-225HP



18-5136
CDI
Reemplaza: 6F5-85540-21-00, 6F5-85540-22-00
Para: 40HP 2 Cilindro (Int'l)



18-25300
CAJA CDI
Reemplaza: 66M-85540-01-00
Para: F9.9(2005-06), F15(2000-06)



MP39160
INTERRUPTOR
PULSADOR MOMENTANEO
Para instalaciones fueraborda.



MP51020 (LLAVE)
MP51022 (CAJA DE 100 PCS)
LLAVE ENCENDIDO
Reemplaza: 703-82510-12-00
Caja de control Yamaha 2 & 4 T
Mismos colores del cableado que el original



MP51030 (LLAVE)
MP51032 (CAJA DE 100 PCS)
LLAVE ENCENDIDO
Reemplaza: 61B-82510-01-00,
61B-82510-00-00
Yamaha montaje salpicadero 2 T
Aplicación motores dobles...



MP51040 (LLAVE)
MP51042 (CAJA DE 100 PCS/CTN)
LLAVE ENCENDIDO
Reemplaza: 703-82510-43-00
Caja control Yamaha 2 & 4 T
Pulsar para el starter
Mismos colores del cableado que el original



MP51050 (LLAVE)
MP51052 (CAJA DE 100 PCS)
LLAVE ENCENDIDO
Reemplaza: 6K1-82510-06-00
Yamaha montaje salpicadero 2 & 4 T
Aplicación montaje doble, Pulsar=starter
Mismos colores que el cableado original



MP28860
HOMBRE AL AGUA
Reemplaza: 682-82556-00-00



18-65450
INTERRUPTOR PARADA MOTOR
Reemplaza: 6E9-82575-02-00
Para: Yamaha 6(1995-00), 8(1995-09),
9.9(1994-95), C30(1994-96), C40(1994-97)



18-5225
KIT CABLES DE BUJÍAS
Kit incluye un rollo de 7,5mts. de cable encendido de Hypalon de 7mm. con alma metálica y un surtido de 3 tipos de terminales para motores fueraborda.



18-5226
CABLE ENCENDIDO
Alma metálica
100' Bobina
7mm Hypalon

Pack. de 10



18-5750
18-5750-9①
TAPA DE BUJÍAS UNIVERSAL
Reemplaza: OMC 581027, 580339
Con terminal conector



18-5752
TAPA DE BUJÍAS UNIVERSAL
8mm

Pack. de 10



18-5224
18-5224-9①
TERMINAL CABLE BUJÍAS
Reemplaza: Mercury 20121
OMC 510364

① Precio por pack

TABLA APLICACIÓN ENCENDIDO YAMAHA FUERABORDA

HP	Año Inicio	Año final	CDI	Bobina encendido	Bobina de carga (Stator)	Bobina de impulso	Bobina iluminación
9.9	1984	1995	18-5131	18-5111	-	-	-
9.9	1996	1998	-	18-23602	18-5183	18-25652	18-25604
9.9	1999	2009	18-5132	18-23602	18-5183	18-25652	18-25604
15	1984	1995	18-5131	18-5112	-	-	-
15	1996	1998	-	18-23602	18-5183	18-25652	18-25604
15	1999	2009	18-5132	-	18-5183	18-25652	18-25604
20	1996	1997	-	18-5113	-	-	-
25	1984	1987	-	-	18-5195	-	-

APLICACIONES CONTINÚAN EN LA SIGUIENTE PÁGINA

TABLA APLICACIÓN ENCENDIDO YAMAHA FUERABORDA

HP	Año Inicio	Año final	CDI	Bobina encendido	Bobina de carga (Stator)	Bobina de impulso	Bobina iluminación
25	1994	2009	-	18-5113	-	-	-
30	1984	1986	-	-	18-5195	-	-
90	1984	1988	-	18-5111	-	-	-
90	1988	1991	18-5130	-	-	-	-
115	1984	1989	18-5135	18-5110	-	-	-
115	1994	2009	-	18-5128	-	-	-
130	1988	1989	18-5135	18-5110	-	-	-
130	1994	2004	-	18-5112	-	-	-
150	1984	1989	-	18-5110	-	-	-
150	1994	2009	-	18-5112	-	-	-
175	1984	1989	-	18-5110	-	-	-
175	1994	1995	-	18-5112	-	-	-
175	2000	2000	-	18-5112	-	-	-
200	1984	1989	-	18-5110	-	-	-
200	1994	1998	-	18-5112	-	-	-
225	1994	1997	-	18-5112	-	-	-
B115	1998	1999	-	18-5112	-	-	-
C25	1992	1995	18-5131	18-5112	-	-	-
C25	1996	1997	18-5131	18-5138	-	-	-
C30	1991	1992	-	-	18-5195	-	-
C30	1993	1997	-	18-5113	-	-	-
C40	1991	1997	-	-	18-5195	-	-
C55	1991	1994	-	18-5111	-	-	-
C75	1994	1996	18-5130	-	-	-	-
C85	1991	1996	18-5130	-	-	-	-
C115	1991	1996	18-5135	18-5110	-	-	-
C115	1997	2000	-	18-5112	-	-	-
C150	1996	1999	-	18-5112	-	-	-
CV25	1990	1990	18-5131	18-5112	-	-	-
CV30	1989	1990	-	-	18-5195	-	-
CV40	1990	1990	-	-	18-5195	-	-
CV55	1989	1990	-	18-5111	-	-	-
CV85	1989	1990	18-5130	-	-	-	-
D150	1997	1999	-	18-5112	-	-	-
E48	1995	1996	-	18-5112	-	-	-
E75	1995	1996	18-5130	-	-	-	-
F6	2001	2008	-	18-5138	-	-	-
F8	2001	2015	-	18-5138	-	-	-
F9.9	2005	2006	18-25300	-	-	18-25650	-
F9.9	2007	2014	-	18-5138	-	-	-
F15	1998	1999	-	-	-	18-25650	-
F15	2000	2005	18-25300	-	-	18-25650	-
F25	1998	2004	-	-	-	-	-
F25	2005	2005	-	-	-	-	-
F30	2001	2005	-	-	-	-	-
F40	2000	2008	-	-	-	-	-
L130	1989	1989	18-5135	-	-	-	-
L130	1994	2001	-	18-5112	-	-	-
L150	1986	1989	-	18-5110	-	-	-
L150	1994	1999	-	18-5112	-	-	-
L200	1986	1989	-	18-5110	-	-	-
L200	1994	1999	-	18-5112	-	-	-
P115	1994	1996	-	18-5112	-	-	-
P150	1994	1999	-	18-5112	-	-	-
P175	1994	1999	-	18-5112	-	-	-

APLICACIONES CONTINUAN EN LA SIGUIENTE PÁGINA

TABLA APLICACIÓN ENCENDIDO YAMAHA FUERABORDA

HP	Año Inicio	Año final	CDI	Bobina encendido	Bobina de carga (Stator)	Bobina de impulso	Bobina iluminación
P200	1994	1999	-	18-5112	-	-	-
PROV150	1986	1989	-	18-5110	-	-	-
S115	1996	1999	-	18-5112	-	-	-
S130	1996	1999	-	18-5112	-	-	-
S150	1996	1999	-	18-5112	-	-	-
S175	1996	1999	-	18-5112	-	-	-
S200	1996	1999	-	18-5112	-	-	-
T8	2001	2010	-	18-5138	-	-	-
T9.9	2005	2006	18-25300	18-23601	-	18-25650	-
T9.9	2007	2014	-	18-5138	-	-	-
T25	2001	2004	-	-	-	-	-
T25	2005	2005	-	18-23205	-	-	-
T25	2006	2006	-	-	-	-	-
V150	2000	2008	-	18-5112	-	-	-
V175	2000	2000	-	18-5112	-	-	-
V6EXCEL	1987	1989	-	18-5110	-	-	-
V6SPECIAL	1984	1986	-	18-5110	-	-	-



**18-5819
SOLENOIDE**

Reemplaza: 65W-81941-00-00
Para: F25 (1998-04), F30 (2001-04), F40 (2000-04)



**18-5853
SOLENOIDE**

Reemplaza: 61A-81941-00-00, 6E5-81941-11-00, 6E5-81941-10-00, 6E5-81941-00-00
Para: 2-tiempos: 115hp - 150hp. (1994-Actual); 175hp (1994-2000); 200hp (1994-2005); 225hp. (1995-2004); 250hp (1990-2004)



**18-5879
SOLENOIDE**

Reemplaza: 688-81950-10-00, 688-81941-00-00
Para: 2-tiempos: 40hp (1984-88); 50hp (1984-88); 60hp. (2001-06); 70hp. (1991-Actual); 90hp. (1984-91)



**18-5746
ENSAMBLAJE STATOR**

Reemplaza: 6H3-85510-A0, 6H3-85510-A1
Para: E60(1995-99), P60(1991), 70(1984-91)



**18-17300
ENSAMBLAJE RECTIFICADOR**

Reemplaza: 65W-81960-10-00
Para: F25(2004 & Sup), F40(2004 & Sup)



**18-6410
MOTOR ARRANQUE FUERABORDA**

Reemplaza: Yamaha 689-81800-13-00, 689-81800-11, 689-81800-12
Para: 25-40HP (11 dientes)



**18-6411
MOTOR ARRANQUE FUERABORDA**

Reemplaza: 6H3-81800-11-00, 6H3-81800-10
Para: 60HP



CE

18-6412
MOTOR ARRANQUE FUERABORDA
Reemplaza: 697-81800-12, 99999-03249-00
Para: 55-60HP 2 cilindros (9 dientes)



CE

18-6413
MOTOR ARRANQUE FUERABORDA
Reemplaza: 6E5-81800-11-00,
6E5-81800-12-00
Para: 55-60HP 2 cilindros (9 dientes)



CE

18-6415
MOTOR ARRANQUE FUERABORDA
Reemplaza: 6N7-81800-10-00
Para: 115-250HP (9 dientes)



CE

18-6420
MOTOR ARRANQUE FUERABORDA
Reemplaza: 6L2-81800-20-00
Para: 20HP MLHU & MSHU (1996),
20HP MLHV & MSHV 1997 25 (1988-98)



CE

18-6421
MOTOR ARRANQUE FUERABORDA
Reemplaza: 6F5-81800-11, 6J4-81800-01-00
Para: 25HP (1998&2001), 30HP (1996-99 & 2001),
40HP (1992-03) C40 1997-02, P40 (1998)
50 (1992-97 & 2000 & 2002-03) C50 (1998-01), P50 (1993-96)



CE

18-6422
MOTOR ARRANQUE FUERABORDA
Reemplaza: 6H4-81800-12-00
Para: 40HP (1984-86), 50HP (1986-88), Pro 50
(1987-88)



CE

18-6423
MOTOR ARRANQUE FUERABORDA
Reemplaza: 688-81800-12-00
Para: C75 (1994-96), (1998-99), P75 (1996-99),
C80 TLRV (1997), C85 (1991-96)
CV85 (1990), 90 (1984-03), B90 (1998-99) C90 (1997-01)



CE

18-6425
MOTOR ARRANQUE FUERABORDA
Reemplaza: 67F-81800-02-00
Para: F75 (2003), F80 (2001-02), F90 (2003), F100
(2001-02)



CE

18-6426
MOTOR ARRANQUE FUERABORDA
Reemplaza: 68F-81800-01-00
Para: LZ150(00-05), LZ200(00-11), VZ150(00-11),
VZ175(01-11), VZ200(01-04), Z150(00-05), Z175(01-
05), Z200(00-11)



CE

18-6427
MOTOR ARRANQUE FUERABORDA
Reemplaza: 68V-81800-01-00
Para: F115 2001-03



18-6832
MOTOR ARRANQUE
Reemplaza: 60V-81800-00-00,
60X-81800-00-00
Para: 250HP 2003-04



18-6833
MOTOR ARRANQUE
Reemplaza: 69J-81800-00-00
Para: 2002-2004 200-225HP



18-6861
MOTOR ARRANQUE
Reemplaza: Yamaha 61A-81800-01-00,
61H-81800-01-00, 69L-81800-00-00
Hitachi S114-559B
Para: Motores Yamaha 200-250HP



18-6942
MOTOR ARRANQUE
Reemplaza: Yamaha 69W-81800-00-00
Hitachi S114-682
Para: 2002-04 60HP, 2003-04 50HP



18-6943
MOTOR ARRANQUE
Reemplaza: 66M-81800-01-00, 02-00
Para: Motores 9.9-15HP



18-6961
MOTOR DE ARRANQUE
Reemplaza: 6CB-81800-00-00
Para: 200, 225, 250 4 Ciclo (2006 & Sup)



18-50000
MANETA
Reemplaza: 689-5755-01-00, 6G1-15779-00-00
Para: Yamaha 15 hp & sup (1988 & sup)



18-50001
MANETA
Reemplaza: 6G1-15755-00-00, 6G1-15779-00-00
Para: 2.5-9.9 hp(1988 & Sup)



18-56007
ALOJAMIENTO ESCOBILLAS
Reemplaza: 61A-81840-00-00
Para motor de arranque: 61A-81800-00-00, 61A-81800-01-00, 69L-81800-00-00
Para: 225 (1991-96), 250 (1990-95), L225 (1994-99), L250 (1990-99), LX225, LX250 (2000-03), P150, P175 (1994-96), P200 1991-96, S225/S250 1996-99), SX225, SX250 (2000-03), V200/V225 (1998-99), VX200 (2000-05), VX225 (2000-04), VX250 (2002-04)



18-56005
ALOJAMIENTO ESCOBILLAS
Reemplaza: 6E5-81840-10-00
Para motores de arranque: 689-81800-13-00 (18-6410), 6H3-81800-11-00 (18-6410), 6F5-81800-11-00, 6J481800-01-00 (18-6421), 6H4-81800-12-00 (18-6422), 6E5-81800-11-00, 6E5-81800-12-00 (18-6413)



18-6798
MOTOR TRIM
Reemplaza: 69J-43880-00-00, 60V-43880-00-00
(Aro incluido)
Para: F200, F225 (2004-06), F250 (2005-06), LF200, LF225, LF250, LZ200, LZ225, LZ250 (2004-06)



18-6748
MOTOR TRIM
Reemplaza: 67C-43880-00-00
Para: F30, F40 (2001 & Sup)

HP	Temp.	Modelo	Año	Motor de arranque	HP	Temp.	Modelo	Año	Motor de arranque
9.9		9.9	1984-1997	18-6420	15		F15MLHA - F15MLHD	2002-2005	18-6943
9.9	4	F9.9ELR2	2006 & SUP	18-6943	15	4	F15MLHK	2006 & SUP	18-6943
9.9		F9.9ELR2D	2005	18-6943	15		F15MLHY - F15MLHZ	2000-2001	18-6943
9.9	4	F9.9MLH2	2006 & SUP	18-6943	15	4	F15MSH	2006 & SUP	18-6943
9.9		F9.9MLH2D	2005	18-6943	15		F15MSHA - F15MSHD	2002-2005	18-6943
9.9	4	F9.9MSH2D	2006 & SUP	18-6943	15	4	F15MSHK	2006 & SUP	18-6943
9.9		F9.9MSH2D	2005	18-6943	15		F15MSHY - F15MSHZ	2000-2001	18-6943
9.9	4	T9.9ELH2	2006 & SUP	18-6943	15	4	F15PLH	2006 & UP	18-6943
9.9		T9.9ELH2D	2005	18-6943	15		F15PLHA - F15PLHD	2002-2005	18-6943
9.9	4	T9.9ELR2 - T9.9EXH2	2006 & SUP	18-6943	15	4	F15PLHK	2006 & SUP	18-6943
9.9		T9.9EXH2D	2005	18-6943	15		F15PLHZ	2001	18-6943
15		15	1984-1997	18-6420	15	4	F15PLR	2006 & SUP	18-6943
15	4	F15ELH	2006 & SUP	18-6943	15		F15PLRA - F15PLRD	2002-2005	18-6943
15		F15ELHA - F15ELHD	2002-2005	18-6943	15	4	F15PLRK	2006 & SUP	18-6943
15	4	F15ELHK	2006 & SUP	18-6943	15		F15PLRZ	2001	18-6943
15		F15ELHY - F15ELHZ	2000-2001	18-6943	25		25 (2 CIL)	1984-1987	18-6410
15	4	F15ESH	2006 & SUP	18-6943	25		25 (2 CIL)	1988-2009	18-6420
15		F15ESHA - F15ESHD	2002-2005	18-6943	25		C25	1991-1997	18-6410
15	4	F15ESHK	2006 & SUP	18-6943	25		CV25	1990	18-6410
15		F15ESHY - F15ESHZ	2000-2001	18-6943	25	2	25ELH	2006 & SUP	18-6420
15	4	F15MLH	2006 & SUP	18-6943	25		25ELH - 25ELN	1984-1987	18-6410

APLICACIONES CONTINUAN EN LA SIGUIENTE PAGINA

HP	Temp.	Modelo	Año	Motor de arranque	HP	Temp.	Modelo	Año	Motor de arranque
25	2	25ELR	2006 & SUP	18-6420	70		70ETLD - 70ETLN	1984-1990	18-6411
25	2	25ESH	2006 & SUP	18-6420	70	2	70TLR	2006 & SUP	18-6411
25		25ESH - 25ESN	1984-1987	18-6410	70		70ETLN - 70TRP	1984-2005	18-6411
25	2	25ESR	2006 & SUP	18-6420	70		C70	2000-2001	18-6411
25		25LH - 25LN	1984-1987	18-6410	70		C70TLRY - C70TLRZ	2000-2001	18-6411
25	2	25MLH	2006 & SUP	18-6420	75		C75	1994-1999	18-6423
25		25MLHX3	1999	18-6421	75		C75TLRS - C75TLRX	1994-1999	18-6423
25	2	25MSH	2006 & SUP	18-6420	75		F75	2003-2004	18-6425
25		25MSHX3 - 25MSHZ3	1999-2001	18-6421	75		F75	2005-2011	18-6427
25		25SH - 25SN	1984-1987	18-6410	75		F75TLRB - F75TLRD	2003-2005	18-6425
25		C25ELD - C25HSHV	1990-1997	18-6410	75		F75TLRD	2005	18-6427
30		30	1984-1986	18-6410	75		P75	1996-1999	18-6423
30		30	1987-2001	18-6421	75		P75TLHU - P75TLHX	1996-1999	18-6423
30		30ELHT - 30ELHY	1995-2001	18-6421	80		C80	1997	18-6423
30		30ELJ - 30ELN	1984-1986	18-6410	80		C80TLRV	1997	18-6423
30		30ELRT - 30ELRZ	1995-2001	18-6421	80		F80	1999-2003	18-6425
30		30ESJ - 30ESN	1984-1986	18-6410	80		F80TJRA - F80TLRZ	2001-2003	18-6425
30		30ESRT - 30MSHZ	1995-2001	18-6421	85		C85	1991-1996	18-6423
30		C30	1991-1997	18-6410	85		C85ELD - C85TLRU	1990-1996	18-6410
30		C30ELD - C30MLHS	1990-1997	18-6410	85		CV85	1989-1990	18-6423
30		CV30	1989-1990	18-6410	85		CV85ELF	1989	18-6410
30		CV30ELF	1989	18-6410	90		90	1984-2009	18-6423
40		40	1984-1988	18-6422	90		90ETLD - 90TJRZ	1984-2001	18-6410
40		40	1989-2005	18-6421	90	2	90TLR	2006 & SUP	18-6410
40		40EJRQ	1992	18-6421	90		90TLRA - 90TLRZ	1991-2005	18-6410
40		40EJRR - 40TLHV	1993-2001	18-6421	90		B90	1997-1999	18-6423
40	2	40TLR	2006 & SUP	18-6421	90		B90TLRV - B90TLRX	1997-1999	18-6410
40		40TLRA - 40TLRZ	1994-2005	18-6421	90		C90	1997-2001	18-6423
40		C40	1991-1997	18-6410	90		C90TLRV - C90TLRZ	1997-2001	18-6410
40		C40ELRP	1991	18-6410	90		F90	2003-2004	18-6425
40		C40ELRQ - C40TLRZ	1992-2001	18-6410	90		F90	2006-2011	18-6427
40		CV40ELD	1990	18-6410	90	4	F90TJR	2006 & UP	18-6427
40		F40TLRX	1999	18-6413	90		F90TJRB - F90TJRC	2003-2004	18-6425
40		P40	1998	18-6421	90	4	F90TLR	2006 & SUP	18-6427
40		P40TLHW - P40TLRW	1998	18-6421	90		F90TLRB - F90TLRC	2003-2004	18-6425
50		50	1984-1988	18-6422	90	4	F90TXR	2006 & SUP	18-6427
50		50	1989-2009	18-6421	100		F100	1999-2003	18-6425
50		50EJRQ - 50TLHV	1992-2001	18-6421	100		F100TLRA - F100TXRZ	2001-2003	18-6425
50	2	50TLR	2006 & SUP	18-6421	115		115	1984-1996	18-6413
50		50TLRA - 50TLRZ	1996-2005	18-6421	115		115	2000-2009	18-6415
50		C50	1998-2001	18-6421	115		115ETLD	1990	18-6413
50		C50TLRW - C50TLRZ	1998-2001	18-6421	115		115ETLD-JD	1990	18-6413
50		F50	1995-2002	18-6413	115		115ETLF	1989	18-6413
50		F50TJRA - F50TLRZ	1995-2002	18-6413	115		115ETLF-JD	1989	18-6413
50		P50	1991-1996	18-6421	115		115ETLG	1988	18-6413
50		P50TLRR - P50TLRU	1993-1996	18-6413	115		115ETLG-JD	1988	18-6413
50		T50	1996-2002	18-6413	115		115ETLH	1987	18-6413
50		T50TLRA - T50TLRY	1996-2002	18-6413	115		115ETLH-JD	1987	18-6413
55		C55	1991-1995	18-6412	115		115ETLJ - 115TXRT	1984-1996	18-6413
55		CV55	1989-1990	18-6412	115		C115	1991-1996	18-6413
60		60	2001-2005	18-6411	115		C115	2000	18-6415
60	2	60TLR	2006 & SUP	18-6411	115		C115LXRQ - C115TXRU	1991-1996	18-6413
60		60TLRA - 60TLRZ	2001-2005	18-6411	115		F115	2000-2011	18-6427
60		C60	1996-2001	18-6411	115	4	F115TJR	2006 & SUP	18-6427
60		C60ELRU - C60TLRZ	1996-2001	18-6411	115		F115TJRA - F115TJRD	2002-2005	18-6427
60		P60	1991-1999	18-6411	115	4	F115TLR	2006 & UP	18-6427
60		P60TLHP - P60TLHX	1991-1999	18-6411	115		F115TLRA - F115TLRZ	2001-2005	18-6427
70		70	1984-2009	18-6411	115	4	F115TXR	2006 & SUP	18-6427

APLICACIONES CONTINUAN EN LA SIGUIENTE PAGINA

HP	Tiemp.	Modelo	Año	Motor de arranque	HP	Tiemp.	Modelo	Año	Motor de arranque
115		F115TXRA - F115TXRZ	2001-2005	18-6427	200		L200ETF - L200TXRU	1986-1996	18-6413
115		LF115	2000-2011	18-6427	200	4	LF200TXR	2006 & SUP	18-6833
115	4	LF115TXR	2006 & SUP	18-6427	200		LF200TXRA - LF200TXRD	2002-2005	18-6833
115		LF115TXRA - LF115TXRD	2002-2005	18-6427	200		LX200	1999-2001	18-6415
115		P115	1993-1996	18-6413	200		LZ200	2002-2011	18-6426
115		P115TLRR - S115TLRU	1993-1996	18-6413	200	2	LZ200TXR	2006 & SUP	18-6426
130		130	1988-1996	18-6413	200		LZ200TXRA - LZ200TXRZ	2000-2005	18-6426
130		130	2000-2004	18-6415	200		P200TLRS - P200TLRU	1994-1996	18-6413
130		130ETLD - 130TXRT	1988-1995	18-6413	200		S200	1996	18-6413
130		L130	1989-1996	18-6413	200		S200TXRU	1996	18-6413
130		L130	2000-2001	18-6415	200		SX200	1999-2005	18-6415
130		L130ETXD - S130TXRU	1990-1996	18-6413	200		V-200	1998-1999	18-6424
150		150	1984-1996	18-6413	200		V200TLRW - V200TLRX	1998-1999	18-6861
150		150	2000-2009	18-6415	200		VX200	2000-2003	18-6424
150		150ETLD - 150TXRT	1990-1997	18-6413	200		VX200TLRA - VX200TLRZ	2001-2003	18-6861
150		C150	1996	18-6413	200		VZ200	2001-2004	18-6426
150		C150TLRU	1996	18-6413	200		VZ200TLRA - VZ200TLRZ	2001-2004	18-6426
150		C150TXRU	1996	18-6413	200		Z200	2000-2011	18-6426
150		DX150	1999-2005	18-6415	200	2	Z200TLR	2006 & SUP	18-6426
150		L150	1986-1996	18-6413	200		Z200TLRD	2005	18-6426
150		L150ETXD - L150TXRU	1986-1996	18-6413	200		Z200TLRY - Z200TLRZ	2000-2001	18-6426
150	4	LF150TXR	2006 & SUP	18-6413	200	2	Z200TXR	2006 & SUP	18-6426
150		LX150	1999-2001	18-6415	200		Z200TXRA - Z200TXRZ	2000-2005	18-6426
150		LZ150	2000-2005	18-6426	225		Z25TUR	1995	18-6861
150	2	LZ150TXR	2006 & SUP	18-6426	225		Z25TXRS	1994	18-6861
150		LZ150TXRA - LZ150TXRZ	2000-2005	18-6426	225		Z25TXRT	1995	18-6861
150		Z150	2000-2005	18-6415	225	4	F225TUR	2006 & SUP	18-6833
150		P150	1991-1996	18-6413	225		F225TURA - F225TURD	2002-2005	18-6833
150		P150TLRQ - P150TLRU	1986-1996	18-6413	225	4	F225TXR	2006 & SUP	18-6833
150		PRO V-150	1986-1990	18-6413	225		F225TXRA - F225TXRD	2002-2005	18-6833
150		S150	1996	18-6413	225		L225	1994-1999	18-6424
150		S150TLRU / S150TXRU	1996	18-6413	225		L225TUR - L225TXRX	1994-1999	18-6861
150		SX150	2000-2001	18-6415	225	4	LF225TUR	2006 & SUP	18-6833
150		V-150	2000-2008	18-6415	225		LF225TURA - LF225TURD	2002-2005	18-6833
150		VX150	2000-2004	18-6415	225	4	LF225TXR	2006 & SUP	18-6833
150		VZ150	2000-2011	18-6426	225		LF225TXRA - LF225TXRD	2002-2005	18-6833
150	2	VZ150TLR	2006 & SUP	18-6426	225		LX225	2000-2003	18-6424
150		VZ150TLRA - Z150TLRZ	2000-2004	18-6426	225		LX225TXRA - LX225TXRZ	2000-2003	18-6861
150	2	Z150TXR	2006 & SUP	18-6426	225		S225	1996-1999	18-6424
150		Z150TXRA - Z150TXRZ	2000-2004	18-6426	225		S225TURU - S225TXRX	1996-1999	18-6861
175		175	1984-1995	18-6413	225		SX225	2000-2003	18-6424
175		175	2000	18-6415	225		SX225TURA - SX225TXRZ	2000-2003	18-6861
175		175ETLD - 175TXRT	1984-1995	18-6413	225		V225	1998-1999	18-6424
175		P175	1994-1996	18-6413	225		V225TLRW - V225TLRX	1998-1999	18-6861
175		P175TLRS - P175TLRU	1994-1996	18-6413	225		VX225	2000-2003	18-6424
175		S175 / S175TXRU	1996	18-6413	225		VX225TLRA - VX225TLRZ	2000-2003	18-6861
175		V-175	2000	18-6415	250		250	1990-1995	18-6424
175		VZ175	2001-2011	18-6426	250		250ETXD - 250TXRT	1990-1995	18-6861
175	2	VZ175TLR	2006 & SUP	18-6426	250		L250	1990-1999	18-6424
175		VZ175TLRA - VZ175TLRZ	2001-2005	18-6426	250		L250ETXD - L250TXRX	1990-1999	18-6861
175		Z175	2001-2005	18-6426	250		LX250	2000-2003	18-6424
175	2	Z175TXR	2006 & SUP	18-6426	250		LX250TURA - LX250TXRZ	2000-2003	18-6861
175		Z175TXRA - Z175TXRZ	2001-2005	18-6426	250		S250	1996-1999	18-6424
200		200	1984-1996	18-6413	250		S250TURU - S250TXRX	1996-1999	18-6861
200		200ETLD - 200TXRT	1984-1996	18-6413	250		SX250	2000-2003	18-6424
200	4	F200TXR	2006 & SUP	18-6833	250		SX250TURA - SX250TXRZ	2000-2003	18-6861
200		F200TXRA - F200TXRD	2002-2005	18-6833			V-6 SPECIAL	1984-1986	18-6413
200	4	F200XTR	2006 & SUP	18-6833			V-6 SPECIAL L	1984	18-6413
200		L200	1986-1996	18-6413			V-6SPECIAL X	1984	18-6413

18-6259
MOTOR TILT/TRIM
Reemplaza: 6H1-43880-00-00
(Incluye Aro)
Para: 70/90HP (1987-91), C85/P60HP (1991)

18-6787
MOTOR TILT/TRIM
Reemplaza: 67F-43880-00-00
(Incluye Aro)
Para: Yamaha 4-Tiempos F75 (2003-04), F80 (1999-03), F90 (2003-04), F100 (1999-02)

18-6788
MOTOR TILT/TRIM
Reemplaza: 6H5-43880-02-00
(Incluye Aro)
Para: Yamaha 40-50hp (1985-92)

18-6789
MOTOR TILT/TRIM
Reemplaza: 62X-43880-09-00
(Incluye Aro)
Para: Yamaha 40-100hp (1995-03)

18-6760
MOTOR TRIM
Reemplaza: 6G5-43880-02-00
(Incluye Aro)
Para: 115-200HP (1987-96)

18-6781
MOTOR TILT/TRIM
Reemplaza: 6HI-43880-02-00
2-cables de conexión, 3 tornillos
Para: 40HP (1994) 50HP (1992-95) 60HP (1997-sup) 70HP (1996-sup) 90HP (1992-sup)

18-6782
MOTOR TILT/TRIM
Reemplaza: 6IA-43880-01-00, 61A-43880-02-00
3-tornillos, 4 cables conexión
(Incluye Aro)
Para: 225-250HP

18-6783
MOTOR TILT/TRIM
Reemplaza: 64E-43880-00-00, 64E-43880-01-00
2-cable 4-tornillos
(Incluye Aro)
Para: 115-225HP (1997-2002)

18-6811
MOTOR POWER TRIM
Reemplaza: 62Y-43880-00-00, 62Y-43880-00-00, 69W-43880-00-00
(Incluye Aro)
Para: 40(2003 & sup), 50(2003 & sup), C40(2003), F50(2003-04), T50(2003-04), 2002-04 60hp 4-tiempos

18-6812
MOTOR TRIM
Reemplaza: 62X-43880-00-00, 62X-43880-01-00, 62X-43880-09-00
Para: 1995-03 Yamaha 40-100HP

18-6821
MOTOR TRIM
Reemplaza: 688-43880-11-00, 6E5-43880-01-00, -02-00
Para: Yamaha 50-200HP 1985-86

18-6836
MOTOR TRIM
Reemplaza: 6C5-43880-00-00
Para: 2005-06 F50 y F60

18-6823
CABLEADO
Convierte de 3 a 2 cables

18-1522
RELE
Reemplaza: 63P-81950-00
Para: 25-150, 220-225 HP (06-Sup), 150 HP(04-Sup)

18-1523
RELE
Reemplaza: 61A-81950-01
Para: F25 HP (98-Sup), T25 HP(01-Sup), 60 HP(93-Sup), 70 HP (93-Sup), 75 HP (94-99), 80 HP (97), 85 HP (93-96), 90 HP (93-09), 150 HP (99-05), 200 HP (98-05), 225 HP (90-04), 250 HP (90-04)

18-1524
RELE
Reemplaza: 6H1-81950-01-00
Para: 40(1994-05), 50 (1994-05), C40(1997-01), C50 (1998-01), F30 (2000-08), F40 (2000-08), F50 (1995-04), F60 (2002-04), P40 (1998), P50 (1992-96), T50 (1996-04), T60 (2003-04)

18-1525
RELE
Reemplaza: 60E-81950-00-00
Para: F30LA (2013-19), F30LEHA (2013-19), F40JEA (2008-19), F40JEHA (2008-19), F40LEHA (2008-19), F40SA(2018-19), F50SA(2018-19), F50LA (2012), F50LB (2013-19), F50TLR (2005-11), T50LA (2012), T50LB(2013-19), T50TLR (2005-11), F60JA(2012), F60JB (2013-19), F60LA (2012), F60LB (2013-19), F60TJR (2005-10), F60TLR (2005-11), T60LA (2012), T60LB (2013-19), T60TLR(2005-11), F70LA (2010-19), F75LA (2012-17), F75TLR (2015-11), F90JA (2012-17), F90LA (2012-17), F90TJR (2005-11), F90TLR (2005-11), F90TXR (2005-11), F90XA (2012-17), LF115XA(2011-18), LF115XA(2011-18), LF115XB(2014-18), F115JA (2011-14), F115JB (2014-18), F115LA (2011-14), F115LB (2014-18), F115XA (2011-14), F115XB (2014-18)

18-7484
ARO
Reemplaza: 65W-43871-00-00
Para: F25-F40 1999-2008 con Power Trim

18-2083
RETEN INYECTOR COMB.
Reemplaza: 68V-13766-00-00

RETENES TRIM

18-2081
Reemplaza: 64E-43822-00-00

18-2082
Reemplaza: 64E-4384J-00-00



18-9802
LUZ PUESTA A PUNTO
Hasta 10,000 RPM's



18-7058
KIT CARBURADOR
Reemplaza: 61N-14392-00-00,
6L2-14392-00-00, 63V-W0093-00-00
Para: 9.9(1996-09), 15(1996-09)



18-7059
KIT CARBURADOR
Reemplaza: 677-W0093-00-00,
677-W0093-04-00
Para: 9.9(1984-85), 15(1984-85)



18-7002
KIT CARBURADOR
Reemplaza: 6E5-W0093-06-00
Para: 115 (1986-88,1992-93, 1995), 130
(1988,1992-93, 1995), 150, 175 (1986-
87, 1992-95), 200 (1986-87,1992-95),
225 (1992-93)

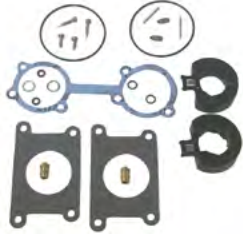

18-7290*
KIT CARBURADOR
Reemplaza: 696-W0093-02-00
*kit contiene componentes suficientes
para reconstruir 2 carburadores

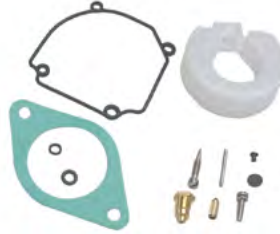

18-7291
KIT CARBURADOR
Reemplaza: 6H1-W0093-01-00
(3) de 18-7291 = (1) de 6H1-W0093-01-00



18-7293
KIT CARBURADOR
Reemplaza: 6A1-W0093-01-00



18-7736
KIT CARBURADOR
Reemplaza: 67D-W0093-00-00
Para: (1999-02) F4



18-7737
KIT CARBURADOR
Reemplaza: 61N-W0093-00-00
Para: (1993-97) C30



18-7738
KIT CARBURADOR
Reemplaza: 66M-W0093-01-00,
66M-W0093-00-00
Para: (1998-02) F15



18-7739
KIT CARBURADOR
Reemplaza: 6L2-W0093-00-00
Para: (1996-97) 20 (1988-02) 25 3 cil



18-7740
KIT CARBURADOR
Reemplaza: 6E9-W0093-02-00
Para: (1990-94) C40 2 cil



18-7741
KIT CARBURADOR
Reemplaza: 6E9-W0093-03-00
Para: (1995-98) C40 2 cil



18-7742
KIT CARBURADOR
Reemplaza: 6H0-W0093-00-00
Para: (1997) C80



18-7743
KIT CARBURADOR
Reemplaza: 67F-W0093-00-00
Para: (1999-02) F80/F100



18-7744
KIT CARBURADOR
Reemplaza: 6N6-W0093-02-00
Para: (1990-91) 115, 130, L130



18-7747
KIT CARBURADOR
Reemplaza: 6G5-W0093-08-00
Para: (1985-86) 150/175/200, V6 especial



18-7756
KIT CARBURADOR
Reemplaza: 64D-W0093-00-00
Para: (1996-01) 150/150L/175 (1996-99)
200/L200 (2000-01) 150/175 (1997-98)
D150

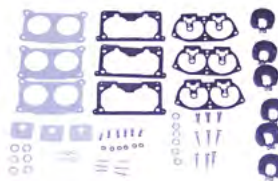

18-7759
KIT CARBURADOR
Reemplaza: 6K7-W0093-09-00
Para: (1990-91) 150/175/200 (1991-92) P200



18-7765
KIT CARBURADOR
Reemplaza: 6G1-W0093-00-00



18-7766
KIT CARBURADOR
Reemplaza: 6H3-W0093-02-00
(3) de 18-7766 = (1) de 6H3-W0093-02-00



18-7767
KIT CARBURADOR
Reemplaza: 6H4-W0093-01-00
(3) de 18-7767 = (1) de 6H4-W0093-01-00



18-7768
KIT CARBURADOR
Reemplaza: 6H4-W0093-03-00
(3) 18-7768 = (1) 6H4-W0093-03-00

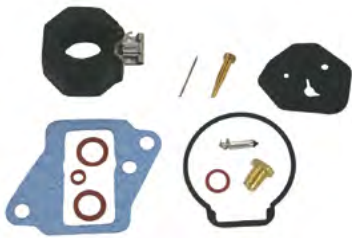

18-7769
KIT CARBURADOR
Reemplaza: 6E7-W0093-04-00



18-7770
KIT CARBURADOR
Reemplaza: 689-W0093-02-00



18-7772
KIT CARBURADOR
Reemplaza: 61A-W0093-01-00, 61A-W0093-00-00
Para: (1991-96) 225/250 3.1 litro, L225, L250



18-34600
CARBURADOR
Reemplaza: 66M-14301-00-00,
66M-14301-12-00
Para: F15(2006 & Sup)



18-34601
CARBURADOR
Reemplaza: 67D-14301-13-00
Para: F4(2005 & Sup)



18-34603
CARBURADOR
Reemplaza: 63V-14301-00-00
Para: 9.9(1996-03), 15(1996-03)



18-34604
CARBURADOR
Reemplaza: 69M-14301-11-00
Para: F2.5MSH(2006 & Sup)



18-34605
CARBURADOR
Reemplaza: 66T-14301-00-00
Para: T40/T30 Enduro Series



18-7049
VÁLVULA DE AGUJA
Reemplaza: 62Y-14392-00-00, 61N-14392-00-00,
6L2-14392-00-00
Para: C30(1993-97)



18-7054
VÁLVULA DE AGUJA
Reemplaza: 6G1-14546-00-00, 6G1-14546-01-00
Para: 3(1988-02), 6(1986-00), 8(1984-03), 9.9(1996-03),
15(1996-03), F25(1998-03), F30(2000-02), F40(2000-02),
T25(2001-03)



18-7055
VÁLVULA DE AGUJA
Reemplaza: 6E5-14546-00-00, 6J8-14546-00-00
Para: 25 MLHV3(1997), 25MLHW3(1998), 25 MSHV3(1997), 25 MSHW3(1998), 30(1987-98), 115(1986-09), 130(1988-04), 150(1986-09), 175(1986-95, 2000), 200(1986-98), 225(1990-97), B115(1998-99), 250(1991-95), C115(1991-00), C150(1996-99), D150(1997-99), L130(1989-01), L150(1986-99), L200(1986-99), L225(1994-96), L250(1990-96), P115(1993-96), P150(1991-99), P175(1994-99), P200(1991-99), S115(1996-99), S130(1996-99), S150(1996-99), S175(1996-99), S200(1996-99), S225(1996), S250(1996), V150(2000-08), V175(2000)



18-7056
VÁLVULA AGUJA
Reemplaza: 6H3-14590-00-00, 6H3-14590-01-00, 67F1439A-00-00, 6H2-14591-00-00
Para: 40(1984-92), 50(1984-92), 70(1984-01), C40(1991-94), C60(1996-01), C70(2000-01), CV40(1990), E60(1995-00), F80(2000-02), F100(2000-02), P50(1991-92), P60(1991-99)



18-7060
VÁLVULA AGUJA
Reemplaza: 692-14590-00-00, 692-14590-01-00
Para: 90(1984-02), B90(1997-99), C75(1994-99), C80(1997), C85(1991-96), C90(1997-01), CV85(1989-90), E75(1995-00), P75(1996-99)



18-7073
VÁLVULA AGUJA
Reemplaza: 6E8-14380-12-00, 6E7-14390-12-00
Para: 9.9(1986-95), 15(1986-95)



18-7079
VÁLVULA AGUJA
Reemplaza: 626-14390-90
Para: 9.9(1984-85), 15(1984-85)



18-7063
FLOTADOR
Reemplaza: 6L2-14385-00-00
Para: 20(1996-97), 25(1988-09), C30(1993-97), F15(1989-06), F40(1999), F50(1995-03), F60(2002-04), F9.9(2005-06), T50(1996-04), T60(2003-04), T9.9(2005-06)



18-7064
FLOTADOR
Reemplaza: 63V-14985-00
Para: 9.9(1996-09), 15(1996-09), F25(1998-13), F30(2001-05), F40(2000-08), T25(2001-13)



18-7065
FLOTADOR
Reemplaza: 647-14385-00-00
Para: 4(1984-85), 5(1984-85), 9.9(1984-85), 15(1984-85)



18-7066
FLOTADOR
Reemplaza: 648-14385-00-00
Para: 25(1984-87), 30(1984-86), C25(1991-97), C30(1991-92), Cv25(1990), CV30(1989-90)



18-7067
FLOTADOR
Reemplaza: 6G1-14985-00-00
Para: 3(1988-02), 6(1986-00), 8(1984-00), 40(1984-88), 50(1984-88), 70(1984-91), C60(1996-01), E60(1995-00), PRO 50(1987-88), P60(1991)



18-7068
FLOTADOR
Reemplaza: 6E5-14385-01-00, 6E5-14385-00-00
Para: 115(1984), 150(1984), 175(1984), 200(1984)



18-7069
FLOTADOR
Reemplaza: 6E5-14385-02-00
Para: 115(1986-09), 130(1988-04), 150(1986-09), 175(1986-00), 200(1986-98), 200(1990-97), B115(1989-99), C115(1991-00), C150(1996-99), D150(1997-99), L130(1989-01), L150(1986-99), L200(1986-99), P115(1993-96), P150(1991-99), P175(1994-99), P200(1991-99), PRO150(1986-90), S115(1996-99), S130(1996-99), S150(1996-99), S175(1996-99), S200(1996-99), V150(2000-08), V6 Excel(1987-89), V6 Special(1986)



18-7392
FLOTADOR
Reemplaza: 676-14985-01-00
Para: 90(1984-90), C40(1991-97), C75(1994-99), C80(1997), C85(1991-96), CV40(1990), CV85(1989-90), E75(1995-00)



18-7393
FLOTADOR
Reemplaza: 6E7-14385-00-00
Para: 4(1986-94), 5(1994), 9.9(1986-95), 15(1986-95)



18-0710
JUNTA CAMARA DE FLOTADOR
Reemplaza: 68V-14984-00
Para: F115 (2000-10), LF115 (2000-10), F200 (2002-10), LF200 (2002-10), F225(2002-05), LF225(2002-05), F225TXR modelos(2007-10), LF225TXR modelos(2007-10)



18-0711
JUNTA CAMARA DE FLOTADOR
Reemplaza: 66K-14984-00
Para: DX 150(1999-05), LX 150(1999-01), LZ 150(2000-05), PX 150(1999), VX 150(2000-04), VZ 150(2000-10), Z 150(2000-05), VZ 175(2001-10), Z175(2001-05), LX200(1999-01), LZ200(2000-10), SX200(1999-05), V200(1999), VX200(2000-05), VZ200(2001-09), Z200 (2000-10), L225(1999), LX225(2000-03), S225(1999), SX225(2000-03), V225(1999), VX225(2000-04), VZ225(2003-09), L250(1999), LX250(2000-03), LZ250(2003-05), S250(1999), SX250(2000-03), VX250(2002-04), VZ250(2003-09), Z250(2003-05), LZ300(2004-06), VZ300(2004-09), Z300(2004-06)



18-0712
JUNTA CAMARA DE FLOTADOR
Reemplaza: 63P-14984-00
Para: F150 TLR (2004-10), F150 TXR (2004-10), LF150 TXR (2004-10)



18-0713
JUNTA CAMARA DE FLOTADOR
Reemplaza: 6P2-14984-00
Para: F225TLR(2007-09), F250(2005-10), LF250(2005-10)



18-0714
JUNTA CAMARA DE FLOTADOR
Reemplaza: 6AW-14984-00
Para: F300(2007-09), LF300(2007-09), F350(2007-10), LF350(2007-10)



18-0715
JUNTA CAMARA DE FLOTADOR
 Reemplaza: 65L-14984-00
 Para: V200(1998), L225(1997-98), S225(1997-98), V225(1998), L250(1997-98), S250(1997-98)

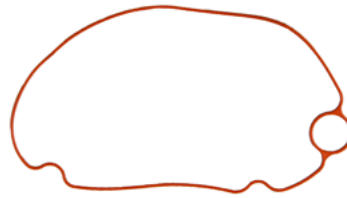

18-0716
JUNTA CAMARA DE FLOTADOR, VITON
 Reemplaza: 6CB-14984-00
 Para: F115(2001-14), F200(2011-14), F225(2010-14), F250(2010-14), F300(2010-14), F350(2011-14), FL250(2010), FL300(2010), LF115(2011-14), LF200(2011-14), LF225(2010-14), LF250(2010-14), LF300(2010-14), LF350(2011-14), VF150(2013-14), VF200(2010-14), VF225(2010-14), VF250(2009-14)

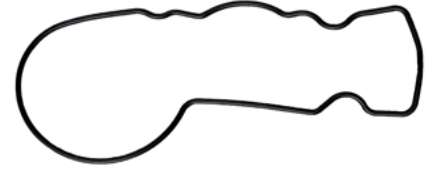

18-0717
JUNTA CAMARA FLOTADOR, VITON
 Reemplaza: 6C5-14984-00
 Para: F50(2005-14), F60(2005-14), F70(2010-14), F75(2005-14), F90(2005-14), T50(2005-14), T60(2005-14)



18-99146
JUNTA CAMARA FLOTADOR
 Reemplaza: 677-14384-01
 Para: 9.9(1984-95), 15(1984-95)



18-0707
RETÉN, VITON
 Reemplaza: 6CB-13016-00
 Para: F115(2011-14), F175(2014), F200(2011-14), F225(2010-14), F250(2010-14), F300(2010-14), F350(2012-14), FL250(2010), FL300(2010), LF115(2011-14), LF200(2011-14), LF225(2010-14), LF250(2010-14), LF300(2010-14), LF350(2012-14), VF150(2013-14), VF200(2010-14), VF225(2009-14), VF250(2009-14)

H.P.	Año	kit carb	Por motor	Válvula aguja	Por motor	H.P.	Año	kit carb	Por motor	Válvula aguja	Por motor
2	1984-88	18-7293	1			PRO 50	1989-90	18-7768	3		
3	1988-02	18-7765	1	18-7054	1	P50	1991-92	18-7768	3	18-7056	3
F4	1999-02	18-7736	1			P50	1993-96	18-7768	3		
6	1986-96	18-7765	1	18-7054	1	C55	1991-95	18-7290	2		
6	1997-00		1	18-7054	1	CV55	1989-90	18-7290	2		
8	1984-96	18-7765	1	18-7054	1	60	2001-02			18-7056	3
8	1997-00		1	18-7054	1	C60	1996-01	18-7766	3	18-7056	3
9.9	1984-85	18-7059	1	18-7079	1	E60	1995-00	18-7766	3	18-7056	3
9.9	1986-95	18-7769	1	18-7073	1	P60	1991	18-7766	3	18-7056	3
9.9	1996-03	18-7058	1	18-7054	1	P60	1992-99			18-7056	3
9.9	2004-09	18-7058	1			70	1984-91	18-7766	3	18-7056	3
F9.9	2006	18-7738	1			70	1992-01			18-7056	3
T9.9	2005-06	18-7738	1			C70	2000-01			18-7056	3
15	1984-85	18-7059	1	18-7079	1	C75	1994-97	18-7291	3	18-7060	3
15	1986-92	18-7769	1	18-7073	1	C75	1998-99	18-7742	3	18-7060	3
15	1993-95			18-7073	1	E75	1995-00	18-7291	3	18-7060	3
15	1996-03	18-7058	1	18-7054	1	P75	1996-99			18-7060	3
15	2004-09	18-7058	1			C80	1997	18-7742	3	18-7060	3
F15	1998-05	18-7738	1			F80	1999-02	18-7743	3	18-7056	3
20	1996-97	18-7739	1			C85	1991-96	18-7291	3	18-7060	3
25 (2 cil)	1984-87	18-7770	1			CV85	1989-90	18-7291	3	18-7060	3
25 (2 cil)	1988-09	18-7739	1			90	1984-91	18-7291	3	18-7060	3
F25	1998-03		1	18-7054	1	90	1992-02			18-7060	3
C25	1991-1997	18-7770	1			B90	1997-99			18-7060	3
CV25	1990	18-7770	1			C90	1997-01			18-7060	3
T25	2001-03		1	18-7054	1	F100	1999-02	18-7743	3	18-7056	3
30	1984-86	18-7770	1			115	1986-88, 1992-95	18-7002	2	18-7055	4
30	1987-98		1	18-7055	1	115	1990-91	18-7744	2	18-7055	4
F30	2000-02		1	18-7054	1	115	1992-09		2	18-7055	4
C30	1991-92	18-7770	1			B115	1998-99			18-7055	4
C30	1993-97	18-7737	1	18-7049	1	C115	1991			18-7055	4
CV30	1989-90	18-7770	1			C115	1992-95	18-7002	2	18-7055	4
40	1984-88	18-7767	3	18-7056	3	C115	1996-00			18-7055	4
40	1989-92	18-7768	3	18-7056	3	P115	1993-96	18-7002	2	18-7055	4
40	1993-05	18-7768	3			S115	1996-99			18-7055	4
F40	2000-02			18-7054	3	130	1988, 1992-95	18-7002	2	18-7055	4
C40	1991-93	18-7740	1	18-7056	2	130	1990-91	18-7744	1	18-7055	4
C40	1994-97	18-7741	1			130	1992-04			18-7055	4
C40	2002-03	18-7768	3			L130	1989			18-7055	4
P40	1998	18-7768	1			L130	1990-91	18-7744	1	18-7055	4
E48	1995-00	18-7290	2			L130	1992-95	18-7002	2	18-7055	4
50	1984-88	18-7767	3	18-7056	3	L130	1996-01			18-7055	4
50	1989-92	18-7768	3	18-7056	3	S130	1996-99			18-7055	4
50	1993 & Sup	18-7768	3			150	1985-86	18-7747	1	18-7055	6
C50	1998-01	18-7768	3			150	1987, 1992-95	18-7002	3	18-7055	6
PRO 50	1987-88	18-7767	3			150	1990-91	18-7759	1	18-7055	6

H.P.	Año	kit carb	Por motor	Válvula aguja	Por motor	H.P.	Año	kit carb	Por motor	Válvula aguja	Por motor
150	1996-01	18-7756	3	18-7055	6	S175	1996-99	18-7756	3	18-7055	6
150	2002-09			18-7055	6	V175	2000	18-7756	3		
C150	1996-99	18-7756	3	18-7055	6	200	1985	18-7747	2		
D150	1997-99	18-7756	3	18-7055	6	200	1986-87, 1992-95	18-7002	3	18-7055	6
L150	1988, 1992-95	18-7002	3	18-7055	6	200	1990-91	18-7759	1	18-7055	6
L150	1990-91	18-7759	1	18-7055	6	200	1996-98	18-7756	3	18-7055	6
L150	1996-99	18-7756	3	18-7055	6	L200	1988, 1992-95	18-7002	3	18-7055	6
Z150						L200	1990-91	18-7759	1	18-7055	6
P150	1991	18-7759	1	18-7055	6	L200	1996-99	18-7756	3	18-7055	6
P150	1992-95	18-7002	3	18-7055	6	P200	1991	18-7759	1	18-7055	6
P150	1996-99	18-7756	3	18-7055	6	P200	1993-95	18-7002	3	18-7055	6
PRO V150	1987	18-7002	3			P200	1996-99	18-7756	3	18-7055	6
PRO V150	1990	18-7759	1			S200	1996-99	18-7756	3	18-7055	6
S150	1996-99	18-7756	3	18-7055	6	V6 Special	1984-86	18-7747	2		
V150	2000-01	18-7756	3			V6 Excel	1987-89	18-7759	1		
V150	2002-08			18-7055	6	225	1990-91	18-7759	1	18-7055	6
175	1985-86	18-7747	2			225	1992-95	18-7002	3	18-7055	6
175	1987, 1992-95	18-7002	3	18-7055	6	225	1996-97	18-7756	3	18-7055	6
175	1990-91	18-7759	1	18-7055	6	L225	1994-96	18-7772	6	18-7055	6
175	1992-95			18-7055	6	S225	1996	18-7772	6	18-7055	6
175	2000	18-7756	3	18-7055	6	250	1990-95	18-7772	6	18-7055	6
P175	1994-95	18-7002	3	18-7055	6	L250	1991-96	18-7772	6	18-7055	6
P175	1996-99	18-7756	3	18-7055	6	S250	1996	18-7772	6	18-7055	6

* Kit carburador contiene componentes suf. para reconstruir 2 carb

18-35302
ENS.BOMBA COMBUSTIBLE
Reemplaza: 66M-24410-10-00
Para: F9.9(2005-06), T9.9(2005-06), F15(1998-06)



18-7334
BOMBA COMBUSTIBLE

Reemplaza:
692-24410-00-00, 663-24410-00-00,
6A0-24410-00-00, 6A0-24410-05-00,
6A0-24410-04-00, 6A0-24410-03-00,
6A0-24410-02-00, 6A0-24410-01-00
Para: 2-tiempos 40 HP - 90 HP (1984-
2009). Use kit 18-7797



18-7340
BOMBA COMBUSTIBLEE
Reemplaza: 68V-13907-03-00,
68V-13907-02-00, 68V-13907-01-00,
68V-13907-00-00
Para: F115(2000-04, 2006-11), LF115(2000-11)



18-7341
BOMBA COMBUSTIBLE

Reemplaza: 66K-13907-00-00
Para: DX150(1999-01), LX150(1999-
01), LX200(1999-01), LX225(2000-
01), LX250(2000-01), PX150(1999),
SX150(1999-01), SX200(1999-01),
SX225(2000-01), SX250(2000-01),
V200(1999), V225(1999), VX150(2000-01),
VX200(2000-01), VX225(2000-01)



18-7342
BOMBA COMBUSTIBLE

Reemplaza: 68F-13907-00,
68F-13907-01-00, 68F-13907-00-00
Para: LZ150(2000-05), LZ200(2000-
12), VZ150(2000-12), VZ175(2001-12),
VZ200(2001-04), Z150(2000-05), Z175(2001-
05), Z200(2000-12)



18-7343
BOMBA COMBUSTIBLE

Reemplaza: 60V-13907-00-00
Para: LZ250(2003-05), LZ300(2004-
06), VZ200(2005-09), VZ225(2003-09),
VZ250(2003-09), VZ300(2004-09),
Z250(2003-05), Z300(2004-06)



18-7349
BOMBA COMBUSTIBLE

Reemplaza:
6E5-24410-03-00,
6E5-24410-10-00,
6E5-24410-04-00,
6E5-24410-02-00,
6E5-24410-01-00,
6E5-24410-00-00
Para: 2-tiempos 115 HP - 300 HP (1984-
2004)
Use Kit 18-7788



18-7388
DIAFRAGMA

Reemplaza: 6G1-24411-00-00
Para: 3(1988-02), 6(1986-00), 8(1984-09),
9.9(1996-09), 15(1996-09)



18-7389
DIAFRAGMA

Reemplaza: 6E0-24411-00-00
Para: 4(1984-99), 5(1984-85, 1994-02)



18-7390
DIAFRAGMA

Reemplaza: 63V-24411-00-00
Para: 9.9(1996-09), 15(1996-09)

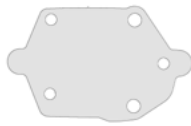

18-7391
DIAFRAGMA

Reemplaza: 692-24411-00-00
Para: 40(1995-05), 50(1995-09), 60(2001-
05), 70(1995-09), 90(1995-09), B90(1997-99),
C25(1996-97), C30(1996-97), C40(1995-03),
C50(1998-01), C55(1995), C60(1996-01),
C70(2000-01), C75(1995-99), C80(1997),
C85(1995-96), C90(1997-01), E48(1995-00),
E60(1995-00), E75(1995-00), P40(1998),
P50(1995-96), P60(1995-99), P75(1996-99)



18-7787
KIT BOMBA COMBUSTIBLE

Para: 40-90 HP

- CONTIENE -	
Ref #	Descripción O.E. #
18-7840	Diafragma (Front) 663-24411-00-00
18-7839	Diafragma 648-24411-00-00



18-7788
KIT BOMBA COMBUSTIBLE

Reemplaza: 6E5-24411-00-00
(V-4, V-6)

- CONTIENE -	
Ref #	Descripción O.E. #
18-7843	Junta (Post.) 6E5-24411-00-00
18-7842	Diafragma (Sup.) 6E5-24471-00-00

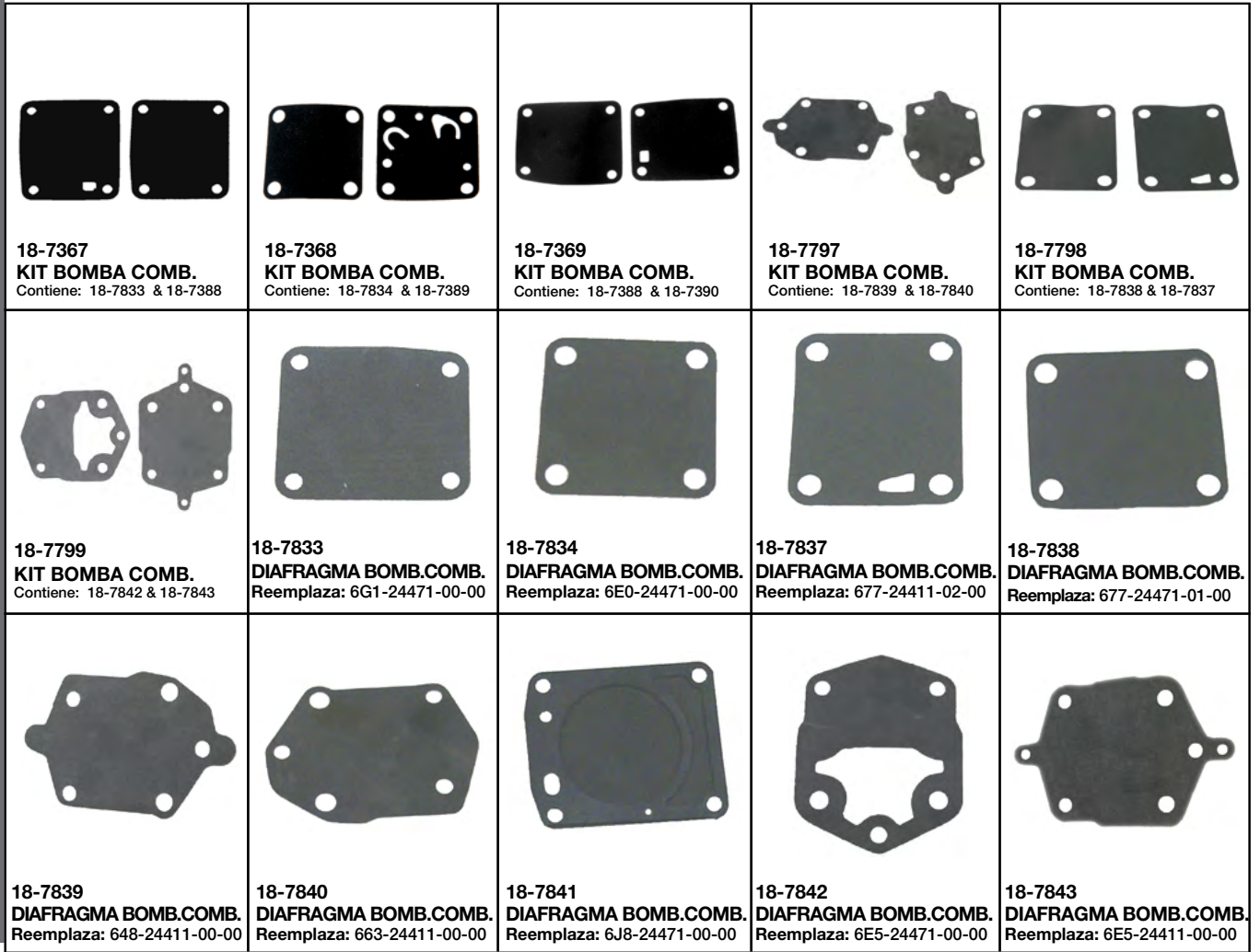

18-7367
KIT BOMBA COMB.
Contiene: 18-7833 & 18-7388

18-7368
KIT BOMBA COMB.
Contiene: 18-7834 & 18-7389

18-7369
KIT BOMBA COMB.
Contiene: 18-7388 & 18-7390

18-7797
KIT BOMBA COMB.
Contiene: 18-7839 & 18-7840

18-7798
KIT BOMBA COMB.
Contiene: 18-7838 & 18-7837

18-7799
KIT BOMBA COMB.
Contiene: 18-7842 & 18-7843

18-7833
DIAFRAGMA BOMB.COMB.
Reemplaza: 6G1-24471-00-00

18-7834
DIAFRAGMA BOMB.COMB.
Reemplaza: 6E0-24471-00-00

18-7837
DIAFRAGMA BOMB.COMB.
Reemplaza: 677-24411-02-00

18-7838
DIAFRAGMA BOMB.COMB.
Reemplaza: 677-24471-01-00

18-7839
DIAFRAGMA BOMB.COMB.
Reemplaza: 648-24411-00-00

18-7840
DIAFRAGMA BOMB.COMB.
Reemplaza: 663-24411-00-00

18-7841
DIAFRAGMA BOMB.COMB.
Reemplaza: 6J8-24471-00-00

18-7842
DIAFRAGMA BOMB.COMB.
Reemplaza: 6E5-24471-00-00

18-7843
DIAFRAGMA BOMB.COMB.
Reemplaza: 6E5-24411-00-00

Modelo	Año	Diafragma	Kits	Modelo	Año	Diafragma	Kits	Modelo	Año	Diafragma	Kits
3	1988-02	18-7833 / 18-7388	18-7367	E75	1995-00	18-7840		VZ175	2002-04	18-7842 / 18-7843	18-7799
4	1984-99	18-7834 / 18-7389	18-7368	P75	1996-99	18-7840		Z175	2001-01	18-7842	
5	1984-85	18-7834 / 18-7389	18-7368	C80	1997	18-7840		Z175	2002-04	18-7842 / 18-7843	18-7799
5	1986-91	18-7834		85	1990	18-7798		200	1984-98	18-7842 / 18-7843	18-7799
5	1994-02	18-7834 / 18-7389	18-7368	C85	1991-94	18-7839 / 18-7840	18-7797	L200	1986-99	18-7842 / 18-7843	18-7799
6	1986-00	18-7833 / 18-7388	18-7367	C85	1995-96	18-7840		LX200	1999-01	18-7842	
8	1984-09	18-7833 / 18-7388	18-7367	CV85	1989-90	18-7839 / 18-7840	18-7797	LZ200	2000-01	18-7842	
9.9	1984-95	18-7837 / 18-7838	18-7798	90	1984-94	18-7839 / 18-7840	18-7797	LZ200	2002-04	18-7842 / 18-7843	18-7799
9.9	1996-09	18-7388 / 18-7390	18-7369	90	1995-09	18-7840		P200	1991-99	18-7842 / 18-7843	18-7799
15	1984-95	18-7837 / 18-7838	18-7798	B90	1997-99	18-7840		S200	1996-99	18-7842 / 18-7843	18-7799
20	1996-09	18-7388 / 18-7390	18-7369	C90	1997-01	18-7840		SX200	1999-01	18-7842	
20	1996-97	18-7837		I15	1984-04	18-7842 / 18-7843	18-7799	SX200	2002-04	18-7842 / 18-7843	18-7799
25	1984-87	18-7840		B115	1998-99	18-7842 / 18-7843	18-7799	V200	1999	18-7842	
25	1984-87			C115	1991-00	18-7842 / 18-7843	18-7799	V200	1998	18-7842 / 18-7843	18-7799
25	1988-09	18-7837		P115	1993-96	18-7842 / 18-7843	18-7799	VX200	2000-01	18-7842	
C25	1991-95	18-7840	18-7797	S115	1996-99	18-7842 / 18-7843	18-7799	VX200	2002-04	18-7842 / 18-7843	18-7799
C25	1996-97	18-7840		130	1988-04	18-7842 / 18-7843	18-7799	VZ200	2001	18-7842	
CV25	1990	18-7839 / 18-7840	18-7797	C150	1996-99	18-7842 / 18-7843	18-7799	VZ200	2002-04	18-7842 / 18-7843	18-7799
25	1990	18-7837		L130	1989-99	18-7842 / 18-7843	18-7799	Z200	2000-01	18-7842	
30	1984-86	18-7839 / 18-7840	18-7797	L130	2000-01	18-7842		Z200	2002-04	18-7842 / 18-7843	18-7799
30	1987-90	18-7841		S130	1996-99	18-7842 / 18-7843	18-7799	225	1990-97	18-7842 / 18-7843	18-7799
30	1991-02	18-7841		150	1984-04	18-7842 / 18-7843	18-7799	L225	1994-99	18-7842 / 18-7843	18-7799
C30	1991-95	18-7839 / 18-7840	18-7797	D150	1997-99	18-7842 / 18-7843	18-7799	LX225	2000-01	18-7842	
C30	1996-97	18-7840		L150	1986-99	18-7842 / 18-7843	18-7799	LX225	2002-03	18-7842 / 18-7843	18-7799
CV30	1989-90	18-7839 / 18-7840	18-7797	LX150	1999-01	18-7842		S225	1996-99	18-7842 / 18-7843	18-7799
40	1984-94	18-7839 / 18-7840	18-7797	LZ150	2000-01	18-7842		SX225	2000-01	18-7842	
40	1995-01	18-7840		LZ150	2002-04	18-7842 / 18-7843	18-7799	SX225	2002-03	18-7842 / 18-7843	18-7799
C40	1991-94	18-7839 / 18-7840	18-7797	DX150	1999-01	18-7842		V225	1999	18-7842	
C40	1995-02	18-7840		DX150	2002-04	18-7842 / 18-7843	18-7799	V225	1998	18-7842 / 18-7843	18-7799
CV40	1990	18-7839 / 18-7840	18-7797	P150	1991-99	18-7842 / 18-7843	18-7799	VX225	2000-01	18-7842	
P40	1998	18-7840		S150	1996-99	18-7842 / 18-7843	18-7799	VX225	2002-04	18-7842 / 18-7843	18-7799
E48	1995-00	18-7840		SX150	1999-01	18-7842		VZ225	2003-04	18-7842 / 18-7843	18-7799
50	1986-94	18-7839 / 18-7840	18-7797	SX150	2002-04	18-7842 / 18-7843	18-7799	250	1990-95	18-7842 / 18-7843	18-7799
50	1995-09	18-7840		V150	2000-01	18-7842		L250	1990-99	18-7843	
C50	1998-01	18-7840		V150	2002-04	18-7842 / 18-7843	18-7799	LX250	2000-01	18-7842	
P50	1991-94	18-7839 / 18-7840	18-7797	VX150	2000-01	18-7842		LX250	2002-03	18-7842 / 18-7843	18-7799
P50	18-1995-96	18-7840		VX150	2002-01	18-7842 / 18-7843	18-7799	LZ250	2003-04	18-7842 / 18-7843	18-7799
55	1990	18-7798		VZ150	2000-04	18-7842		S250	1996-99	18-7842 / 18-7843	18-7799
C55	1991-94	18-7839 / 18-7840	18-7797	VZ150	2002-04	18-7842 / 18-7843	18-7799	SX250	2000-01	18-7842	
CV55	1989-90	18-7839 / 18-7840	18-7797	Z150	2000-01	18-7842		SX250	2002-03	18-7842 / 18-7843	18-7799
60	2001-05	18-7840		Z150	2002-04	18-7842 / 18-7843	18-7799	VX250	2002-04	18-7842 / 18-7843	18-7799
C60	1996-01	18-7840		PRO 150H	1987			VZ250	2003-04	18-7842 / 18-7843	18-7799
E60	1995-00	18-7840		7798				Z250	2003-04	18-7842 / 18-7843	18-7799
P60	1991-94	18-7839		175	1984-95	18-7842 / 18-7843	18-7799	LZ300	2004	18-7842 / 18-7843	18-7799
70	1984-94	18-7839 / 18-7840	18-7797	175	1996-00	18-7842		VZ300	2004	18-7842 / 18-7843	18-7799
70	1995-09	18-7840		P175	1994-99	18-7842 / 18-7843	18-7799	Z300	2004	18-7842 / 18-7843	18-7799
C70	2000-01	18-7840		S175	1996-99	18-7842 / 18-7843	18-7799	V6			
C75	1994	18-7839 / 18-7840	18-7797	V175	2000	18-7842		Special	1984-86	18-7842 / 18-7843	18-7799
C75	1995-99	18-7840		VZ175	2001	18-7842		V6 Excel	1987-89	18-7842 / 18-7843	18-7799

- DISEÑO UNIVERSAL -

SOPORTES SEPARADORES COMBUSTIBLE/AGUA



Tipo soporte	Ref #	Reemplaza	Tipo	Ref #	Reemplaza
1/4" Acero inox	18-7777	MAR-FLTHD-SS-12	1/4" Aluminio	18-7853-1	MAR-FLTHD-AL-12
3/8" Acero inox	18-7776		3/8" Aluminio	18-7775	

KITS SEPARADORES COMBUSTIBLE/AGUA



KITS FILTROS DE 21 MICRAS PARA MOTORES CON CARBURADOR



Tipo kit	Ref #	Micras	Contenido	Reemplaza
1/4" Aluminio (Filtro corto)	18-7848-1 508522	21	1 - 18-7844 filtro & 1 18-7853-1 Soporte 2 - 18-4256 1/4" tapones	
1/4" Pack Aluminio Contiene filtro recambio	18-7848-2	21	2 - 18-7844 filtro & 1 18-7853-1 Soporte 2 - 18-4256 1/4" tapones	
1/4" Aluminio (Filtro alto)	18-7852-1	21	1 - 18-7845 filtro & 1 18-7853-1 Soporte 2 - 18-4256 1/4" Tapones	MAR-SEPAR-AT-OR
1/4" Pack aluminio Contiene filtro recambio	18-7852-2	21	2 - 18-7845 filtro & 1 18-7853-1 Soporte 2 - 18-4256 1/4" Tapones	
3/8" Aluminio (Filtro alto)	18-7775-1	21	1 - 18-7845 filtro & 1 18-7775 Soporte 2 - 18-4264 3/8" Tapones	
1/4" Acero inox. (Filtro alto)	18-7777-1	21	1 - 18-7845 filtro & 1 18-7777 Soporte 2 - 18-4256 1/4" Tapones	ABB-SPRTR-HD-SS
3/8" Acero inox. (Filtro alto)	18-7776-1	21	1 - 18-7845 filtro & 1 18-7776 Soporte 2 - 18-4264 3/8" Tapones	



FILTROS DE 10 MICRAS PARA MOTORES DE INYECCIÓN

Tipo Kit	Ref #	Micras	Contenido	Reemplaza
1/4" Aluminio (Filtro corto)	18-7983-1	10	1 - 18-7944 filtro & 1 18-7853-1 soporte 2 - 18-4256 1/4" tapones	
1/4" Pack aluminio Contiene filtro recambio	18-7983-2	10	2 - 18-7944 filtro & 1 18-7853-1 soporte 2 - 18-4256 1/4" tapones	
1/4" Aluminio (Filtro alto)	18-7982-1	10	1 - 18-7945 filtro & 1 18-7853-1 soporte 2 - 18-4256 1/4" tapones	
1/4" Pack aluminio Contiene filtro recambio	18-7982-2	10	2 - 18-7945 filtro & 1 18-7853-1 Soporte 2 - 18-4256 1/4" tapones	
1/4" Aluminio (Filtro alta capacidad)	18-7966-1	10	1 - 18-7866 filtro & 1 18-7853-1 Soporte 2 - 18-4256 1/4" Tapones	MAR-SEPAR-AT-OR
3/8" Aluminio (Filtro alto)	18-7986-1	10	1 - 18-7945 filtro & 1 18-7775 Soporte 2 - 18-4264 3/8" Tapones	
1/4" Acero inox (Filtro alto)	18-7984-1	10	1 - 18-7945 filtro & 1 18-7777 Soporte 2 - 18-4256 1/4" Tapones	MAR-SPRTR-HD-SS
3/8" Acero inox (Filtro alto)	18-7985-1	10	1 - 18-7945 filtro & 1 18-7776 Soporte 2 - 18-4264 3/8" Tapones	

Sistema de combustible
YAMAHA



KITS FILTROS DE 10 MICRAS CON CAZOLETA DE DRENAJE

Permiten el drenaje y alargan la vida útil del filtro. Usar AquaVue™ para fueraborda, instalaciones bajo cubierta.

Kit Tipo	Ref #	Micron Rating	Contiene
1/4" Aluminio con cazoleta AquaVue™	18-7932-1	10	1 - 18-7919 filtro & 1 18-7853-1 soporte 1 - 18-7922-1 Cazoleta AquaVue™ 2 - 18-4256 1/4" tapones
1/4" Aluminio con cazoleta metálica	18-7951	10	1 - 18-7919 filtro & 1 18-7853-1 soporte 1 - 18-7924 Cazoleta metálica 2 - 18-4256 1/4" tapones
1/4" Acero inox con cazoleta AquaVue™	18-7937-1	10	1 - 18-7919 filtro & 1 18-7777 soporte 1 - 18-7922-1 Cazoleta AquaVue™ 2 - 18-4256 1/4" tapones
1/4" Acero inox con cazoleta metálica	18-7938	10	1 - 18-7919 filtro & 1 18-7777 soporte 1 - 18-7924 Cazoleta metálica 2 - 18-4256 1/4" tapones

SOPORTE Y KIT - PARA APLICACIONES EN PEQUEÑOS FUERABORDAS Y AGUA DULCE

18-7774

SOPORTE DE ALUMINIO COMPACTO



18-7965-1

KIT SEPARADOR COMPACTO 10 MICRAS

Reemplaza: MAR-MINIF-LT-AS

Contiene:

1 - 18-7774 soporte
1 - 18-7865 Filtro



FILTROS DE RECAMBIO



**DISEÑO UNIVERSAL
REEMPLAZO DIRECTO PARA MERCURY
PARA MERCURY Y YAMAHA**

FILTROS DE RECAMBIO DE 10 MICRAS

Ref #	Descripción	Reemplaza
18-7944	Corto - 3.875"	
18-7945	Largo - 4.35"	ABB-FUELF-IL-TR
18-7866	Alta capacidad - 6"	MAR-FUELF-IL-TR
18-7865	Compacto 10 Micras	MAR-MINIF-IL-TR

FILTROS DE RECAMBIO DE 10 MICRAS

Ref #	Descripción	Reemplaza
18-7844	Corto - 3.875"	
18-7845	Largo - 4.35"	ABB-FUELF-IL-TR



**FILTROS DE RECAMBIO DE 10 MICRAS Y
KITS CON CAZOLETA DE DRENAJE**

FILTROS DE RECAMBIO

Ref #	Descripción	Reemplaza
18-7919	Recambio	MAR-24563-00-00 Racor S3213
18-7920	Recambio	Racor S3214
18-7947	Recambio • Para - 120RRAC01	Racor S3240
18-7948	Recambio • Para - 320RRAC01	Racor S3227
18-7949	Recambio • Para - 660RRAC02	Racor S3232

FILTROS DE RECAMBIO

Ref #	Descripción	Reemplaza
18-7922-1	Cazoleta AquaVue™	
18-7924	Cazoleta metálica	MAR-10171-00-10

FILTROS Y CAZOLETAS

Ref #	Descripción
18-7928-1	Filtro & AquaVue™ cazoleta • Tipo Mercury/Yamaha Contiene: 18-7919 filtro, cazoleta 18-7922-1
18-7929	Filtro & Cazoleta metálica • Tipo Mercury/Yamaha Contiene: 18-7919 filtro, Cazoleta 18-7924



18-8953
**TAPA SEPARADORA DE
COMBUSTIBLE/AGUA**
Para: Yamaha mini-10 talla filtro



18-8954
**TAPA SEPARADORA DE
COMBUSTIBLE/AGUA**
Para: Yamaha 18-7866 talla filtro



18-7486
ARO,
CAZOLETA FILTRO
COMBUSTIBLE
Reemplaza:
61A-24564-00-00
Para: V6



18-7487
ARO, ELEMENTO FILTRO
COMBUSTIBLE
Reemplaza:
65L-24564-00-00
Para: V6



18-7488
JUNTA,
CAZOLETA FILTRO
COMBUSTIBLE
Reemplaza:
6P3-24564-00-00
Para: F/LF 150 - F300 (2006 - Actual),
VZ150 - VZ300 (2006 - Actual), Z200 -
Z300 (2006 - Act.)



18-7710
FILTRO COMBUSTIBLE
Reemplaza:
68T-24251-00-00
Para: F6, F8 (2001 & Sup)



18-7713
FILTRO COMBUSTIBLE
(EN LINEA)
Reemplaza: 646-24251-02-00
Para: 6 (1989, 1992-99), 8 (1989-99,
2001-02), F4 (1999-02), F9.9 (1989-95,
1997-99, 2001-02), FT 9.9 (1988-90)



18-7780
FILTRO COMBUSTIBLE
Reemplaza:
6F5-24563-00-00
Para: 9.9 - 225NR



18-7781
FILTRO COMBUSTIBLE
Reemplaza:
61N-24563-00-00
Para: 9.9/90° SX



18-7782
FILTRO COMBUSTIBLE
Reemplaza:
61A-24563-00-00
Para: V6, 3.1L, D-T



18-7516
FILTRO COMBUSTIBLE
Reemplaza: 67F-24251-02-00
Para: F100(1999-01)



18-7517
FILTRO COMBUSTIBLE
Reemplaza: 65L-24563-00-00
Para: 150-250 (1997-05)



18-7955
ELEMENTO FILTRO
COMBUSTIBLE 10 MICRONES
Reemplaza: 68F-24563-10-00
Para: 150hp -300hp. (2004-2006)
Modelos Z, VZ, LZ



18-7979
FILTRO COMBUSTIBLE
Reemplaza: 68V-24563-00-00



18-79799
FILTRO COMBUSTIBLE
Reemplaza: 6D8-WS24A-00-00
F50-F115 despues abril 2006
Para filtro alojamiento solo "6D8" !



18-79809
FILTRO COMBUSTIBLE
Reemplaza: 6P3-24563-01-00,
6P3-WS24A-00-00, 6P3-
WS24A-01-00
F150, F200, F225, F250, Z-VZ 150 a 300
hp. posterior Abril 2006
Para filtro alojamiento solo"6P3"



18-79905
FILTRO COMBUSTIBLE 10
MICRONES
Reemplaza: 69J-24501-10-00
Para: F150 - F225 (2006 - Actual), F250 -
(2005 -Actual)



18-79970
FILTRO COMBUSTIBLE
Reemplaza: 6BG-13915-00
Para: F30(2013), F40(2008-13), F50(2005-13),
F60(2005-13), F70(2010-13), F75(2005-13),
F90(2005-13), T50(2005-13), T60(2005-13)



18-79972
ELEMENTO, FILTRO
(ENTRADA CARB)
Reemplaza: 67F-14371-01
Para: F75(2003-04), F80(2002-03),
F90(2003-04), F100(2002-03)



18-79973
FILTRO COMBUSTIBLE
Reemplaza: 6C5-13915-00
Para: F75(2005-13), F60(2005-13), F70(2010-13),
F75(2005-13), F90(2005-13), T50(2005-13), T60(2005-13)



FILTRO COMBUSTIBLE

Ref #	Aplicación:
18-7828-1	1/4" Capacidad pequeña (Para 1/4" Línea combustible)
18-7829	1/4" Capacidad larga (Para 1/4" Línea combustible)
18-7830	5/16" Reemplaza: 65W-24251-10-00
18-7831	3/8"



18-79977
FILTRO COMBUSTIBLE
Reemplaza: 6L5-24251-00
Para: 3(1992-02), F2.5(2003-12), F4(1999-08)



18-79979
FILTRO COMBUSTIBLE
Reemplaza: 6CB-24501-00
F225 4.2L (2010), F250 4.2L (2010), F300 4.2L (2010), LF225 4.2L (2010), LF250 4.2L (2010), LF300 4.2L (2010), VF200 4.2L (2009-10), VF225 4.2L (2009-10), VF250 4.2L (2009-10)



18-79980
FILTRO COMBUSTIBLE
REEMPLAZA: 68F-24563-00
Para: LZ150(2000-04), LZ200(2000-04), LZ250(2003-04), VZ150(2000-04), VZ175(2001-04), VZ200(2001-04), VZ225(2003-04), VZ250(2003-04), Z150(2000-04), Z175(2001-04), Z200(2000-04), Z250(2003-04)

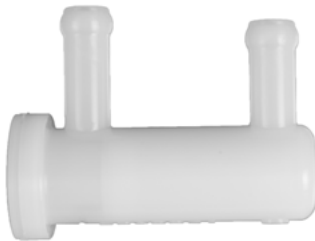

18-79981
FILTRO COMBUSTIBLE
Reemplaza: 69J-24501-00
Para: F150(2004-05), F200(2002-05), F225(2002-05), LF150(2004-05), LF200(2002-05), F225(2002-05)



18-79982
FILTRO COMBUSTIBLE
Reemplaza: 69J-24502-00
Para: F150(2005-14), F200(2005-10), F225(2005-10), F75(2005-14), F90(2005-14), FL150(2010), LF150(2005-14), LF200(2005-10), LF225(2005-10)



18-79983
FILTRO COMBUSTIBLE
Reemplaza: 6C5-24251-00
Para: F115(2014-15), F30(2013-15), F40(2008-15), F50(2005-15), F60(2005-15), F70(2010-15), F75(2005-15), F90(2005-15), LF115(2014-15), T50(2005-15), T60(2005-11), VF115(2015)



18-79984
FILTRO COMBUSTIBLE
Reemplaza: 6AW-24502-10, 6AW-24502-00-00
Para: 2007-09, F350(2007-11), FL350(2010), LF300(2007-09), LF350(2007-11)



18-79985
FILTRO COMBUSTIBLE
Reemplaza: 68V-24502-30, 68V-24502-20-00
Para: F115(2010-11), LF115(2010-11)



18-79986
FILTRO COMBUSTIBLE
Reemplaza: 68V-24502-02, 68V-24502-01-00, 68V-24502-00-00
Para: F115(2005-09), LF115(2005-09)



18-79907
FILTRO VST
Reemplaza: 60V-24251-01-00
Para: LZ150(2005), VZ150(2005-10), Z150(2005), VZ175(2005-10), Z175(2005), LZ200(2005-10), VZ200(2005-09), Z200(2005-10), VZ225(2005-09), LZ250(2005), VZ250(2005-09), Z250(2005), LZ300(2005-06), VZ300(2005-09), Z300(2005-06)



18-79900
FILTRO VST (TAN)
Reemplaza: 66K-13915-00-00
Para: DX150 (1999-05), LX150 1999-01, PX150 (1999), SX150 (1999-04), VX150 (2000-04), LX200 (1999-01), SX200 (1999-05), V200 (1999), VX200 (2000-05), L225 (1999), LX225 (2000-03), S225 (1999), SX225 (2000-03), V225 (1999), VX225 (2000-04), L250 (1999), LX250 (2000-03), SX250 (2000-03), VX250 (2002-04)



18-79901
FILTRO VST (azul)
Reemplaza: 66L-13915-00-00
Para: L225 (1997-98), S225 (1997-98), L250 (1997 - 98), V200 (1998), V225 (1998)

**18-79902
FILTRO VST**

Reemplaza:
63P-13915-00-00
Para: F150 TXR(2004-09), F150 TLR(2004-09), F150 TJR(2009), LF150 TXR(2004-09), F250 TXR(2005-09), F250 TUR(2005-09), F300 TXR(2007-09), F300 TUR(2007-09), F350 TXR(2007-09), F350 TUR(2007-09), F225TLR (2007-09)



**18-79903
FILTRO VST**

Reemplaza:
68V-13915-00-00
Para: F115 (2000-09), F200 TXR(2002-09), LF200 TXR(2002-09), F225 TXR(2002-09), F225 TUR(2002-09)



**18-79904
FILTRO VST (AMARILLO)**

Reemplaza:
68F-13915-00-00
Para: HPDI 150(2000-05), V-Max HPDI 150(2000-09), V-Max HPDI 175(2001-09), HPDI 200(2000-09), HPDI 225(2003-09), HPDI 250 (2003-09), HPDI 300(2004-09)



**18-79978
FILTRO VST**

Reemplaza: 6CB-13915-00
Para: F225 4.2L (2010), F250 4.2L (2010), F300 4.2L (2010), LF225 4.2L (2010), LF250 4.2L (2010), LF300 4.2L (2010), VF200 4.2L (2009-10), VF225 4.2L (2009-10), VF250 4.2L (2009-10)



**18-79910
FILTRO COMBUSTIBLE**

Reemplaza: 61N-24560-00, 61N-24560-10
Para: 15(1994-09), 20(1996-97), 25(1994-09), 30(1995-01), 40(1994-05), 50(1994-09), 60(2001-05), 70(1994-09), 9.9(1994-09), 90(1994-09), B90(1997-99), C25(1994-97), C30(1994-97), C40(1994-03), C50(1998-01), C55(1994-95), C60(1996-01), C75(1994-99), C80(1997), C85(1994-96), C90(1997-01), E48(1995-00), E60(1995-00), E75(1995-00), F15(2005-10), F20(2006-10), F25(2005, 2009-10), F40(1999), F50(1995-04), F9.9(2005-06)



**18-79950
KITS VST**

Reemplaza: Kit 1
Para: F150(04-12), LF150(04-12)



**18-79951
KITS VST**

Reemplaza: Kit 2
Para: F115(00-11), F200(02-10), F225(02-06), F225TXR(07-10), LF115(00-11), LF200(02-10), LF225(02-06), LF225 TXR(07-10)
Incluye filtro 18-79903 VST



**18-79952
KITS VST**

Reemplaza: Kit 3
Para: DX150(99-05), L225(99), L250(99), LX150(99-01), LX200(99-01), LX225(00-03), LX250(00-03), PX150(99), S225(99), S250(99), SX150(99-04), SX200(00-05), SX225(00-03), SX250(00-03), V200(99), V225(99), VX150(00-04), VX200(00-05), VX225(00-04), VX250(02-04)
Incluye 18-79900 VST filtro & 18-0711 junta

**18-79953
KITS VST**

Reemplaza: Kit 4
LZ150(00-05), LZ200(00-11), LZ225(03-05), LZ300(04-06), VZ150(00-11), VZ175(01-11), VZ200(01-09), VZ225(03-09), VZ250(03-09), VZ300(04-09), Z150(00-05), Z175(01-05), Z200(00-11), Z250(03-05), Z300(04-06)
Incluye 18-79904 VST filtro

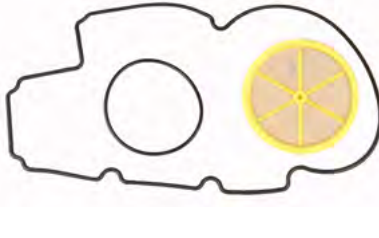

NEW

**18-79954
KIT VST FILTRO & JUNTA**

Para: F225TLR (2007-2009), F250 (2005-2010), LF250 (2005-2010)



NEW

**18-79955
KIT VST FILTRO & JUNTAS**

Para: F300 (2007-2009), LF300 (2007-2009), F350 (2007-2010), LF350 (2007-2010)



NEW

**18-79956
KIT VST FILTRO & JUNTA**

Para: F115 (2001-2014), F200 (2011-2014), F250 (2010-2014), F300 (2010-2014), F350 (2011-2014), FL250 (2010), FL300 (2010), LF115 (2011-2014), LF200 (2011-2014), LF225 (2010-2014), LF250 (2010-2014), LF300 (2010-2014), LF350 (2011-2014), VF150 (2013-2014), VF200 (2010-2014), VF225 (2010-2014), VF250 (2009-2014)



NEW

**18-79957
KIT VST FILTRO & JUNTA**

Para: F50 (2005-2014), F60 (2005-2014), F70 (2010-2014), F75 (2005-2014), F90 (2005-2014), T50 (2005-2014), T60 (2005-2014)



**18-2083
RETÉN INYECTOR COMBUSTIBLE**

Reemplaza:
68V-13766-00-00





18-7655
SENSOR OXÍGENO
Reemplaza: 67H-8592A-01-00,
67H-8592A-00-00
Para: PX150 (1999), DX150 (99-05),
LX150, LX200 (99-01), VX150 (00-04)



18-7656
SENSOR OXÍGENO
Reemplaza: 68F-8592A-00-00
Para: L225, L250 (98-99), LX225, LX250 (00-03), LZ150
(00-05), LZ200 (00-12), S225, S250 (97-99), SX150 (99-
04), SX200 (99-05), SX225, SX250 (00-03), V200, V225
(98-99), VX200 (00-05), VX225 (98-05), VX250 (02-04),
VZ150 (00-14), VZ175 (01-12), VZ200 (01-04), Z150 (00-
05), Z175 (01-05), Z200 (00-12)



18-7606
SENSOR DE AGUA
Reemplaza: MAR-10171-30-00

LÍNEAS DE COMBUSTIBLE LONGITUD 2,44 mts.

3/8"
LÍNEA DE COMB.

18-8017EP-1 SILVERADO 4000 Premium

OE# 6YL-24306-60-00



*



18-8077-1
CONECTOR
DEPÓSITO
(SE VENDE SEPARADO)



18-8076
CONECTOR
COMBUSTIBLE

18-8005S
BOMBA MANUAL

18-8076
CONECTOR
COMBUSTIBLE



*

COMPONENTES DE LA LÍNEA DE COMBUSTIBLE

Para: F75-F250 y 115-300 HP

* Depósitos y motores ilustrativos.



112356
Línea de Combustible Universal
Longitud: 2 mts.

112358
Línea de Combustible Universa
Longitud: 3 mts.



112363
Línea de Combustible Yamaha



112361
Línea de Combustible Yamaha



112351
Kit bomba de combustible y manguera Sirflex
Longitud: 2 mts.

112355
Kit bomba de combustible y manguera Sirflex
Longitud: 3 mts.



112364
Kit bomba combustible y manguera Sirflex
Longitud: 2 mts.



BOMBA DE MANO



18-8002S 1/4"
BOMBA DE MANO
1/4" (6-7 mm)

18-8005S 3/8"
112352 (8-10 mm)
BOMBA DE MANO
3/8" (9-10 mm)
Reemplaza: 174512
Gran capacidad

18-8004 5/16"
112350 (8 mm)
BOMBA DE MANO
5/16" (8 mm)
Gran capacidad



18-8040
CODO DEPÓSITO
Rosca
1/4" NPT
Reemplaza: ABA-FBARB-90-DG
(Latón)



18-8055S
115415
CONECTOR MANGUERA
1/4" NPT dientes conector manguera de 5/16" D.I
Reemplaza: ABA-FLINE-BA-RB
(Latón)



18-8077-1
18-8077-1-10 ①
CONECTOR DEPÓSITO
(1/4" NPT)
Para: F75-F250 y 115-300HP
para: 18-80413, 18-80414, 18-80415



18-80413
CONECTOR COMBUSTIBLE
1/4"
Reemplaza: 6Y1-24305-06-00, 6Y1-24305-04
Para: 18-8077-1



18-80414
CONECTOR COMBUSTIBLE
Reemplaza: 6G1-24305-05-00, 6G1-24305-04
Para: 6 (1989,1992-93), 8 (1984-85,1989-93,2001-02), 9.9 (1984-93, 2000-03), 15 (1984-93, 2000-03), 25 (1984-85, 1988-93, 2000-03), 30 (1984-87, 1989-93, 1999, 2001-02), 40 (1984-86, 1988-90, 1992-93, 2000-03), 50 (1986-93, 2000-03), 60 (2001-03), 70 (1984-93, 2000-03), 90 (1984-93, 2000-03), C25 (1991, 1993), C30 (1991-93), C40 (1991-93, 2000-02), C50 (2000-01), C55 (1991-93), C60 (2000-01), C70 (2000-01), C85 (1991-93), C90 (2000-01), E48 (2000), F6 (2001-03), F8 (2001-03), F9.9 (1985-93, 2001-03), F15 (1998-99, 2000-01), F25 (1998-99, 2000-03), F30 (2001-03), F40 (1999, 2000-03), F50 (1999, 2000-03), F60 (2002-03), T8 (2001-03), T9.9 (1991-93, 1999, 2001-03), T25 (2001-03), T50 (1999, 2000-03), T60 (2003)
Use con Yamaha 6mm línea combustible
Para 18-8077-1



18-80415
CONECTOR COMBUSTIBLE
Reemplaza: 6E5-24305-05, 6Y2-24305-05
Use con Yamaha 8mm línea combustible
Para: 18-8077-1























Referencia	Ø	Referencia	Ø
016734	8-16mm	016744	110-130mm
016735	12-20mm	016745	140-160mm
016736	20-32mm		
016750	25-35mm		
016737	24-40mm		
016738	35-50mm		
016739	40-60mm		
016740	50-70mm		
016741	60-80mm		
016742	70-90mm		
016743	90-110mm		



016734
ABRAZADERAS INOXIDABLES NORMA
Abrazaderas a tornillo sin fin. Fleje ancho anticortante de 12mm (excepto Ref. 016734, y Ref. 016735 con eje de 9mm). Tornillo inox. Con cabeza hexagonal ranurada de 7mm. Fabricados, totalmente, en Acero inoxidable AISI 316. W5.

① Pack de 10 - Precio por embalaje

 <p>18-3040 CEF 18-3040S IMPULSOR Reemplaza: 63V-44352-01-00 Para: T8 (2001-Sup) /9.9/15 (2-tiempos) (1996-Sup)/F15 (1998-Sup), F20 (2006-Sup)</p>	 <p>18-3042 IMPULSOR Reemplaza: 67F-44352-00-00 Para: F75 (03-05), F80 Jet Drive (2001-02), F80 (1999-03), F100 (1999-02), F90 (2003-05), F90 Jet Drive (2003-04)</p>	 <p>18-3063 IMPULSOR Reemplaza: 662-44352-01-00 (6/8 HP)</p>	 <p>18-3065 IMPULSOR Reemplaza: 6L2-44352-00-00 (25 HP)</p>
 <p>18-3066 IMPULSOR Reemplaza: 6G1-44352-00-00 (6 & 8 HP)</p>	 <p>18-3067 IMPULSOR Reemplaza: 689-44352-02-00 (25 HP)</p>	 <p>18-3068 IMPULSOR Reemplaza: 6H4-44352-00-00, 6H4-44352-02-00 (30,40,50 HP)</p>	 <p>18-3069 IMPULSOR Reemplaza: 6H3-44352-00-00, 697-44352-00-00 55, 60, 70 HP, F50, T50</p>
 <p>18-3070 IMPULSOR Reemplaza: 688-44352-03-00 (C75, C85, 90 HP)</p>	 <p>18-3071 IMPULSOR Reemplaza: 6E5-44352-00-00, 6E5-44352-01-00 (115, 150, 175, 200, 250 HP)</p>	 <p>18-3072 IMPULSOR Reemplaza: 646-44352-01-00 (2 HP)</p>	 <p>18-3073 CEF 18-3073S IMPULSOR Reemplaza: 6E0-44352-00-00 (4 & 5 HP)</p>
 <p>18-3074 CEF 18-3074S IMPULSOR Reemplaza: 682-44352-01-00 (9.9,15 HP)</p>	 <p>18-3088 IMPULSOR Reemplaza: 6F5-44352-00-00 (C40 HP)</p>	 <p>18-8910 IMPULSOR Reemplaza: 68T-44352-00-00 Para: F6, F8 (2001-Sup)</p>	 <p>18-8911 IMPULSOR Reemplaza: 6L5-44352-00-00 Para: 3(1988-02), F2.5(2003-12)</p>
 <p>18-8925 IMPULSOR Reemplaza: 6AW-44352-00-00 Para: F300, F350, LF 300, LF 350 & FL350 (2006 & Sup)</p>	 <p>18-43716 PASADOR IMPULSOR Reemplaza: 93604-18080-00 Para: 3(1988-02), 4(1984-99), 5(1984-01), F2.5(2003-14), F4(1999-14), F6(2009-14)</p>	 <p>18-3162 ALOJAMIENTO IMPULSOR Reemplaza: 67F-44322-00-00 Para: F75 (2003-04), F80(1999-03), F90(2003-04), F100(1999-02)</p>	 <p>18-3164 ALOJAMIENTO IMPULSOR Reemplaza: 6L5-44322-00-00 Para: F2.5 (2003-04), 3 (1988-99, 2002)</p>

APLICACIONES EMPIEZAN EN LA PÁGINA 284
TABLA APLICACIONES POR MOTOR EN LA PÁGINA 276

 <p>18-3456 ALOJAMIENTO IMPULSOR Reemplaza: 6G1-44322-00-00 Para: 6 (1986-00), 8 (1984-05)</p>	 <p>18-3333 ALOJAMIENTO IMPULSOR Reemplaza: 61A-44322-00-00</p>	 <p>18-3435 ALOJAMIENTO IMPULSOR Reemplaza: 663-44322-00-00</p>	 <p>18-3328 ALOJAMIENTO IMPULSOR Reemplaza: 646-44322-00-00 Para: 2 (1989,1991-99,2002)</p>	
 <p>18-3443 ALOJAMIENTO IMPULSOR Reemplaza: 61N-44322-01-00 Para: (1998-03) F25, (1993-97) C30</p>	 <p>18-3444 ALOJAMIENTO IMPULSOR Reemplaza: 63V-44322-00-00 Para: 9.9/15 (1996-04), F15 (1998-04), F6/F8/T8 (20001-04)</p>	 <p>18-3449 ALOJAMIENTO IMPULSOR Reemplaza: 63D-44322-00-00 Para: 40 (1995-04), 50 (1995-97, 1999-04)</p>	 <p>18-3519 ALOJAMIENTO IMPULSOR Reemplaza: 61A-44322-02-00 Para: F225 despues 04/2007 / F250 despues 4/2006</p>	 <p>18-3185 BOMBA AGUA ALOJAMIENTO Reemplaza: 61N-44311-01-00, 61N-44311-00-00 Para: C30 (1993-97), F25 (1998-06)</p>
 <p>18-43263 BOMBA AGUA ALOJ. Reemplaza: 68D-G4311-01-00 Para: Yamaha F4(2002-08)</p>	 <p>18-3170 BOMBA AGUA ALOJ. Reemplaza: 6E5-44311-00-00</p>	 <p>18-3171 BOMBA AGUA ALOJ. Reemplaza: 688-44311-01-00</p>	 <p>18-3173-1 BOMBA AGUA ALOJ. Reemplaza: 61A-44311-00-00, 61A-44311-01-00</p>	 <p>18-3356 BOMBA AGUA ALOJ. Reemplazar: 63V-44301-00-00 Para: 2-tiempos: 9.9hp-15hp (1996-actual), 4-tiempos: 6hp-8hp (2001-actual); 9.9hp. (2006-actual); 15hp (1998-actual)</p>
 <p>18-3482 ALOJAMIENTO BOMBA AGUA Reemplaza: 6CE-44311-01-00</p>	 <p>18-3486 ALOJAMIENTO BOMBA AGUA Reemplaza: 6L2-44311-01-00 Para: F25C (2016-17)</p>	 <p>18-3483 ALOJAMIENTO BOMBA AGUA Reemplaza: 6AW-44311-01-00 Para: F300, LF300 (2007-09), F350A, LF350A (2010-11), F350B, LF350B (2012-15), F350C, LF350C (2013-18), FL350 (2010)</p>	 <p>18-3484 ALOJAMIENTO BOMBA AGUA Reemplaza: 6AW-44311-01-00 Para: F15C, F20 (2006-17)</p>	
 <p>18-3485 ALOJAMIENTO BOMBA AGUA Reemplaza: 6CJ-44311-00-00 Para: F70A (2010-17)</p>	 <p>18-4567 ALOJAMIENTO BOMBA AGUA Reemplaza: 6AH 44311-00 Para: F4 (2009-17), F6 (2009-17)</p>	 <p>18-9081 ALOJAMIENTO TAPA BOMBA AGUA Reemplaza: 6E5-44312-00-00 Para: 75 (2017), 90 (2016-20017), 115 (1984-2017), 130 (1988-2004), 150-250 (1984-2017), 250 (1990-2017), 300 (2004-2009)</p>	 <p>18-9082 ALOJAMIENTO TAPA BOMBA AGUA Reemplaza: 6AW-44312-00-00 Para: F225(2010-15), F250 (2010), F250 (2010-15), F300 (2007-15), F350 (2007-15), FL250 (2010), FL300 (2010), FL350 (2010), LF225 (2010-15), LF250 (2010-15), LF300 (2007-15), LF350 (2007-15), VF250 (2015)</p>	

Ref #	O.E. #	Aplicación
18-0256	97095-08045-00 97080-08045-00	8-1.25 x 45mm F6 (2001-05), F8 (2001-05) M8-1.25x45mm 18-8S/S
18-2605	90119-08M87-00	F80 (1999-03), F90 (2003-04), F100 (1999-02) M8-1.25x75mm 18-8 S/S
18-2606	90119-08M13-00	F80 (1999-03), F90 (2003-04), F100 (1999-02) M8-1.25x50mm 18-8 S/S
18-2607	97095-06040-00	Para: 3HP (1988-99, 2002) M8-1.0x40mm 18-8 S/S
18-8400-9 ^{①②}	90119-08M15-00	8-1.25 x 29mm

LLAVE IMPULSORA	
18-3297	90280-03M03-00
18-3305	90280-03024-00, 90280-03003-00
18-3300	90280-04M00-00
18-3301	90280-04M04-00
18-3302	90280-04M05-00



**18-3518
PLATINA**
Reemplaza: 6P2-44323-00-00
Para: F225 despues 04/2007 / F250 despues 4/2006



**18-3520
PLATINA**
Reemplaza: 60X-44323-00-00
Para: VZ200 (3.3L) 2005-2010, VZ225 (3.3L) 2003-2010, VZ250 (3.3L) 2003-2010, VZ300 (3.3L) 2005-2010



**18-3521
PLATINA**
Reemplaza: 68V-44323-00-00
Para: F115 2002-2010 / LF115 2002-2010

① Precio por envase ② Pack. de 4



**18-3194
PLATINA IMPULSOR**
Reemplaza: 61N-44323-00
Para: C30 (1993-97), F25 (1998-06)



**18-3357
PLATINA IMPULSOR**
Reemplaza: 646-44323-00-00
Para: 2 (1989, 1991-99, 2002)



**18-3142
PLATINA IMPULSOR**
Reemplaza: 68T-44323-00-00
Para: F6, F8 (2001-05)



**18-3143
PLATINA IMPULSOR**
Reemplaza: 67F-44323-00-00
Para: F75 (2003-04), F80(1999-03), F90(2003-04), F100(1999-02)



**18-3163
PLATINA IMPULSOR**
Reemplaza: 6L5-44323-00-00
Para: 3HP (1988-99, 2002)



**18-3344
PLATINA IMPULSOR**
Reemplaza: 6E5-44323-00-00



**18-3345
PLATINA IMPULSOR**
Reemplaza: 6G5-44323-00-00



**18-3186
PLATINA IMPULSOR**
Reemplaza: 63D-44323-00-00
Para: 40 (1995-04), 50 (1995-97, 1999-04)



**18-3195
PLATINA IMPULSOR**
Reemplaza: 63V-44323-00-00
Para: 9.9/15 (1996-04), F15 (1998-04)



18-3196
PLATINA IMPULSOR
 Reemplaza: 66T-44323-00-00
 Para: F30 (2001-04), F40 (2000-04),
 T25 (2001-04)



18-3436
PLATINA IMPULSOR
 Reemplaza: 663-44323-00-00



18-1831
DAMPER RETÉN AGUA
 Reemplaza: 682-44366-00
 Para: 9.9(1984-95), 15(1984-95)



18-1832
DAMPER RETÉN AGUA
 Reemplaza: 682-44367-00
 Para: 9.9(1984-95), 15(1984-95)

18-1830
DAMPER RETÉN AGUA

Reemplaza: 663-44366-00
 Para: 25 ML, MS(1997-02), 30(1987-01), 40(1984-05), 50(1986-09), 60(2001-05), 70(1984-09), 90(1984-09), B90(1997-99), C30(1995), C40(1991-01), C50(1998-01), C55(1991-95), C60(1996-01), C70(2000-01), C75(1994-99), C80(1997), C85(1991-96), C90(1997-01), E48(1995-00), E60(1995-00), E75(1995-00), F30(2001-05, 2013), F40(1999-13), F50(1995-13), F60(2002-13), F70(2010-13), F75(2003-11), F80(1999-03), F90(2003-13), F100(1999-03), F200(2002-12), F225(2002-12), F250(2005-12), L225(1994-99), L250(1990-99), LF200(2002-12), LF225(2002-10), LF250(2005-12), LX225(2000-03), LX250(2000-03), LZ250(2003-05), LZ300(2004-06), P40(1998), P50(1991-96), P60(1991-99), P75(1996-99), S225(1996-99), S250(1996-99), SX225(2000-03), SX250(2000-03), T25(2001-13), T50(1996-13), T60(2003-13), V200(1998-99), V225(1998-99), VX200(2000-05), VX225(2000-04), VX250(2002-04), VZ200(2005-09), VZ225(2005-09), VZ250(2003-09), VZ300(2004-09), Z250(2003-05), Z300(2004-06)



18-1828
RETEN
 Reemplaza: 663-44366-00
 Para: F30 (2013-+17), F40A (2008-17)



18-1836
RETEN
 Reemplaza: 6L2-44367-00
 Para: F15C, F20 (2006-17)



18-1837
RETEN
 Reemplaza: 6L2-44367-10
 Para: F25C (2016-17)



18-1840
RETEN
 Reemplaza: 6EE-G4366-00
 Para: F2.5 (2015-17)



18-1829
RETEN
 Reemplaza: 6AW-44365-00-00
 Para: F225 (2010-15), F250 (2010), F250 (2010-15), F300 (2007-15), F350 (2007-15), FL250 (2010), FL300 (2010), FL350 (2010), LF225 (2010-15), LF250 (2010-15), LF300 (2007-15), LF350 (2007-15), VF250 (2015)



CORREAS DENTADAS

REFERENCIA	REEMPLAZA	PARA:
18-15130	6C5-46241-00-00	F25 (2009-2017), T25 (2009-2017), F30 (2013-2017), F40 (2008-2017), F50 (2005-2017), T50 (2005-2010), F60 (2005-2017), T60 (2005-2017), F70 (2010-2017)
18-15131	67F-46241-00-00	F75 (2003-2011), F80 (1999-2003), F90 (2005-2015), F100 (1999-2003), F115 (2000-2014), LF115 (2000-2014)
18-15132	6P2-46241-02-00	F200 (2011-2017), LF200 (201-2017), F225 (2007-2017), F250 (2005-2017), LF250 (2005-2017)
18-15133	6G8-46241-00-00	F9.9 (1985-2005), FT9.9 (1985-1990), T9.9 (1991-2005)
18-15134	6CB-W4624-00-00	F22582010-2017), LF225 (2010-2017), F250 (2010-2017), FL250 (2010-2017), LF250 (2010-2017), F300 (2010-2017), FL300 (2010), LF300 (2010-2017), VF200 (2009-2017), VF225 (2009-2017), VF250 (2009-2017)
18-15135	65W-46241-00-00	F25 (1998-2005), T25 (2001-2005), F30 (2001-2005), F40 (2000-2008)
18-15136	6AH-46241-00-00	F15 (2006-2017), F20 (2006-2017)
18-15137	66M-46241-00-00	F9.9 (2005-2006), F15 (1998-2005)
18-15138	68T-46241-00-00	F6 (2001-2008), T8 (2001-2010), F8 (2001-2017), F9.9 (2007-2017)
18-15139	6AW-W4624-00-00	F300/LF300 (5.3L) (2007-09), F350/LF350 (5.3L) (2007-09), F350A/LF350A (5.3L) (2010-11), F350/LF350 (5.3L) (2012-15), F350C/LF350C (2016-18)
18-15140	63P-46241-00-00	F150/LF150 (2004-11), F150/LF150 (2012-14), F150B/LF150B (2015-18)
18-15141	69J-46241-00-00	F200/LF200 (2002-10), F225/LF225 (2002-10)
18-15142	6DA-W4624-00-00	F150C/LF150C (2017-18), VF150 (2013-17), VF150A (2018)
18-15143	60V-46241-00-00	VZ200 (2005-09), VZ225 (2005-09), VZ250 (2005-09), Z250/LZ250 (2003-05), VZ300 (2005-09), Z300/LZ300 (2004-06)
18-15144	62Y-46241-00-00	F40 (1999), F50 (1995-03), T50 (1996-04), F60 (2002-04), T60 (203-04)
18-15145	68F-46241-10-00	VZ150 (2004-14), Z150/LZ150 (2004-05)

TABLA EQUIVALENCIA TURBINA YAMAHA

MOTOR YAMAHA	REFERENCIA YAMAHA	PRONAUTIC
F6 A,B, F8C, F8F	68T-44352-00-00	18-8910
FT8 D/6, FT9,9G, FT9,9J	68T-44352-00-00	18-8910
F9,9C, F15A	63V-44352-00-00	18-3040
F15C	63V-44352-00-00	18-3040
F20A	6H4-44352-00-00	18-3068
F20B	63V-44352-00-00	18-3040
F25A	6H4-44352-00-00	18-3068
FT25B	6H4-44352-00-00	18-3068
F25G	6L2-44352-00	18-3065
F25D	6H4-44352-00-00	18-3068
FT25F	6H4-44352-00-00	18-3068
F30A	6H4-44352-01-00	18-3068
F30B y F40F	6H4-44352-01-00	18-3068
F40B	6H4-44352-00-00	18-3068
F50A	6H4-44352-00-00	18-3068
FT50B	697-44352-00-00	18-3069
FT50C	697-44352-00-00	18-3069
F50F	6H3-44352-00-00	18-3069
FT50G, FT50J, FT60D, FT60G	6H3-44352-00-00	18-3069
F50H, F60A, F60C, F60F	697-44352-00-00	18-3069
FT60B	6H3-44352-00-00	18-3069
F70A	6H3-44352-00-00	18-3069
F80A F100A	67F-44352-00-00	18-3042
F80C	67F-44352-00-00	18-3042
F100D	67F-44352-00-00	18-3042
F100F	6E5-44352-00-00	18-3071
F115A	6E5-44352-00-00	18-3071
F115B, F130A	6E5-44352-00-00	18-3071
F150A, F150B, F150D, F150F	6E5-44352-01-00	18-3071
F150G, F175A, F175C, F200F, F200G	6E5-44352-01-00	18-3071
F200A, F225A, F200C, F225B, F200C	6E5-44352-01-00	18-3071
F225C, F250A	6E5-44352-01-00	18-3071
F225F, F225B, F250D, F300B, F300C	6CE-44352-00-00	18-45617-1
F300A	6AW-44352-00-00	18-8925
F350A	6AW-W0078-00-00	



18-1833
DAMPER RETÉN
Reemplaza: 647-44366-00
Para: 6(1986-00), 8(1984-00), 9.9(1996-09), 15(1996-09), F9.9(2005-06), F15(1998-06), T9.9(2005-06)



18-1834
DAMPER RETÉN AGUA
Reemplaza: 682-44365-00
Para: 6(1986-00), 8(1984-00), 9.9(1996-09), 15(1996-09), F9.9(2005-06), F15(1998-06), T9.9(2005-06)

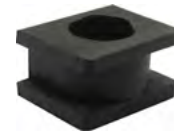

18-3505
DAMPER RETÉN AGUA
Reemplaza: 63V-44365-10-00
Para: 2-tiempos: 9.9hp & 15hp 1997-Actual
4-tiempos: F6 & F/T8 2001-Actual; F/T 9.9 2005-Actual; F15 1998-Actual



18-3166
DAMPER RETÉN AGUA
Reemplaza: 6E0-44366-00-00
Para: 2 (1984-85, 88-99, 2002), 3 (1988-99, 02), 4 (1984-85, 88-99), 5 (1984-85, 95-02), F2.5 (2003-05)



18-3176
DAMPER RETÉN AGUA
Reemplaza: 68T-44366-00-00
Para: F6, F8 (2001-05), C30 (1993-97)



18-9075
ESPACIADOR
Reemplaza: 61A-45538-00-00
Para: 2-tiempos: 115hp.-300hp.(1993-Actual), 4-tiempos: 115hp.-225hp.(2002-Actual)



18-9076
COLLAR
Reemplaza: 61A-45527-00-00
Para: 2-tiempos: 115hp.-300hp. 1993-Actual), 4-tiempos: 115hp.-225hp.(2002-Actual)



18-9077
ARANDELA
Reemplaza: 90206-22M19
Para: 2-tiempos: 115hp.-300hp.(1993-Actual) 4-tiempos: 115hp.-225hp.(2002-Actual)



18-9078
ARANDELA ACERO INOX
Reemplaza: 90201-22M01
Para: 2-tiempos: 115hp.-300hp.(1993-Actual), 4-tiempos: 115hp.-225hp.(2002-Actual)



18-9079
KIT ARANDELA
Para: Yamaha 2-tiempos115-300hp (1993 & Sup); Yamaha 4-tiempos 115-225hp (2002 & Sup); Mercury 4-tiempos 225 EFI S/N 0T653945 & Sup



18-3148
KIT BOMBA DE AGUA
Sin alojamiento
Reemplaza: 682-W0078-A1-00

-- CONTIENE --



18-3397
KIT BOMBA DE AGUA
Sin alojamiento
Reemplaza: 679-W0078-00-00, 679-W0078-A0-00

-- CONTIENE --

Ref #	Descripción	O.E.#	Cant.
18-0768	Junta	682-44315-A0-00	1
18-3074	Impulsor	682-44352-01-00	1
18-3305	Chaveta	90280-03024	1

Ref #	Descripción	O.E. #	Cant.
18-3088	Impulsor	6F5-44352-00	1
18-3300	Chaveta	90280-04M00-00	1
18-0256	Tornillo	97395-08045-00	2















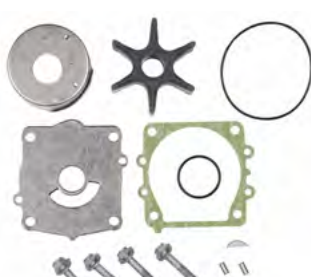



18-3408
KIT BOMBA COMBUSTIBLE CON ALOJAMIENTO
Reemplaza: 6H4-W0078-00, A0, 663-44311-02
Para: 40(1984-87), 50(1984-87), Pro50(1987)



18-3409
KIT BOMBA AGUA CON ALOJAMIENTO
Reemplaza: 67F-W0078-00, 67F-44311-01
Para: F75(2006-10), F80(1999-03), F90(2006-10), F100(1999-03)



18-3410
KIT BOMBA AGUA CON ALOJAMIENTO
Reemplaza: 68T-W0078-00, 63V-44301-00
Para: F6(01-08), F8(01-09), F9.9(07-09)

 <p>18-3411 KIT BOMBA DE AGUA CON ALOJAMIENTO Reemplaza: 682-W0078-A1, 682-44300-01 Para: 9.9(1984-95), 15(1984-95), F9.9(1985-96), FT9.9(1985-90), T9.9(1991-96)</p>	 <p>18-3412 KIT BOMBA DE AGUA CON ALOJAMIENTO Reemplaza: 63V-W0078-01, 63V-44301-00 Para: 9.9(1996-09), 15(1996-09), F9.9(2005-06), F15(1998-05), T9.9(2005-06)</p>	 <p>18-3516 KIT BOMBA DE AGUA CON ALOJAMIENTO Reemplaza: 60X-W0078-00-00 Para: VZ200 (3.3L) 2005-2010, VZ225 (3.3L) 2003-2010, VZ250 (3.3L) 2003-2010, VZ300 (3.3L) 2005-2010</p>	
 <p>18-3442 KIT REPARACIÓN BOMB. DE AGUA Reemplaza: 68V-W0078-00-00 Para: F115 2002-2010 / LF115 2002-2010</p>	 <p>18-3515 KIT BOMBA REPARACIÓN Reemplaza: 6P2-W0078-00-00 Para: F225 fabricado antes 04/2007 / F250 fabricado antes 4/2006</p>	 <p>18-3461 KIT BOMBA AGUA CON ALOJAMIENTO Reemplaza: 6H3-W0078-00-00, A0, 6H3-44311-00 Para: 70(1984-91), P60(1991), T50(1996)</p>	
 <p>18-3466 KIT BOMBA AGUA CON ALOJAMIENTO Reemplaza: 6H3-W0078-01, 6H3-44311-00 Para: 70(1992-03), C60(1996-01), E60(1995-96), P60(1992-99), C70(2000-01), T50(1997-10), T60(2003-10)</p>	 <p>18-3522-1 KIT BOMBA AGUA CON ALOJAMIENTO Reemplaza: 60X-W0078-00, 61A-44311-01 Para: VZ200(2005-09), VZ225(2003-09), VZ250(2003-09), VZ300(2004-09)</p>	 <p>18-3523-1 KIT BOMBA AGUA CON ALOJAMIENTO Reemplaza: 68V-W0078-00, 61A-44311-01 Para: F115 & LF115 (2002 & Sup)</p>	 <p>18-48619 KIT COMPLETO BOMBA DE AGUA Reemplaza: 68D-WG078-00-00 Para: Yamaha F4(2002-08)</p>
 <p>18-3432 KIT BOMBA DE AGUA Reemplaza: 61N-W0078-11-00 Para: F25(1998-05)</p>	 <p>18-3450 KIT BOMBA AGUA Reemplaza: 68T-W0078-00-00 Para: F6, F8 (2001-05)</p>	 <p>18-3451 KIT BOMBA AGUA Reemplaza: 67F-W0078-00-00 Para: F75 (2003-06), F80(1999-03), F90(2003-04), F100(1999-02)</p>	 <p>18-3460 KIT BOMBA AGUA Reemplaza: 6N0-W0078-A0-00, 6G1-W0078-A1-00, 6G1-W0078-01-00 Para: 6(1986-00), 8(1984-05)</p>
 <p>18-3462 KIT BOMBA DE AGUA Reemplaza: 6A1-W0078-02-00 Para: 2(1988-02)</p>	 <p>18-3463 KIT BOMBA DE AGUA Reemplaza: 6A1-W0078-01-00 Para: 2(1984-87)</p>	 <p>18-3464 KIT BOMBA AGUA Reemplaza: 6H3-W0078-01-00 Para: C60(1996), E60(1995-96), P60(1992-96), 70(1992-96)</p>	 <p>18-3465 KIT BOMBA AGUA Reemplaza: 6H3-W0078-02-00 Para: T50(1997-05), 60(2001-03), C60(1997-01), C70(2000-01), P60(1997-99), T60(2003-05), 70(1997-03)</p>

18-3310
KIT BOMBA AGUA
Sin alojamiento
Reemplaza: 6G5-W0078-01-00



— CONTIENE —

Ref #	Descripción	O.E. #	Cant.
18-3071	Impulsor	6E5-44352-00	1
18-3345	Platina impulsor	6G5-44323-00	1
18-3302	Chaveta	90280-04M05-00	1
18-0244	Junta bomba agua	6E5-44315-A0-00	1
18-0256	Tornillo	97395-08045-00	4
18-7483	Aro	93210-37M67-00	1
18-7485	Aro	93210-86M38-00	1

18-3311
KIT BOMBA DE AGUA
Sin alojamiento
Reemplaza: 6G5-W0078-A1-00



— CONTIENE —

Ref #	Descripción	O.E. #	Cant.
18-3170	Alojamiento bomba de agua	6E5-44311-00	1
18-3071	Impulsor	6E5-44352-00	1
18-3345	Platina impulsor	6G5-44323-00	1
18-3302	Chaveta	90280-04M05-00	1
18-0244	Junta bomba de agua	6E5-44315-A0-00	1
18-0256	Tornillo	97395-08045-00	4
18-7483	Aro	93210-37M67-00	1
18-7485	Aro	93210-86M38-00	1

18-3312
KIT BOMBA DE AGUA
Sin alojamiento
Reemplaza: 6N6-W0078-00-00

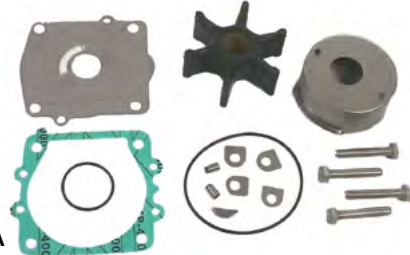

— CONTIENE —

Ref #	Descripción	O.E. #	Cant.
18-3302	Chaveta	90280-04M05-00	1
18-3333	Alojamiento impulsor	61A-44322-00	1
18-3071	Impulsor	6E5-44352-00	1
18-3344	Platina impulsor	6E5-44323-00	1
18-0244	Junta bomba de agua	6E5-44315-A0-00	1
18-0256	Tornillo	97395-08045-00	4
18-7483	Aro	93210-37M67-00	1
18-7485	Aro	93210-86M38-00	1

18-3313-1
KIT BOMBA DE AGUA
Sin alojamiento
Reemplaza: 6N6-W0078-01-00

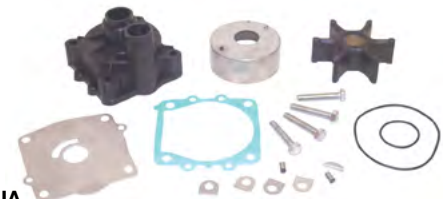

— CONTIENE —

Ref #	Descripción	O.E. #	Cant.
18-3173-1	Alojamiento bomba agua	61A-44311-00	1
18-3302	Chaveta	90280-04M05-00	1
18-3333	Alojamiento impulsor	61A-44322-00	1
18-3071	Impulsor	6E5-44352-00	1
18-3344	Platina impulsor	6E5-44323-00	1
18-0244	Junta bomba agua	6E5-44315-A0-00	1
18-0256	Tornillos	97395-08045-00	4
18-7483	Aros	93210-37M67-00	1
18-7485	Aros	93210-86M38-00	1

18-3370
KIT BOMBA AGUA
Sin alojamiento
Reemplaza: 692-W0078-00-00, 692-W0078-01-00,
692-W0078-A0-00



— CONTIENE —

Ref #	Descripción	O.E. #	Cant.
18-3301	Chaveta	90280-04M04-00	1
18-3070	Impulsor	688-44352-03	1
18-0239	Junta	688-44315-A0-00	1
18-0240	Junta	688-44316-A0-00	1
18-7436	Aro	93210-46044-00	1

18-3371
KIT BOMBA DE AGUA
Con alojamiento
Reemplaza: 692-W0078-A0-00



— CONTIENE —

Ref #	Descripción	O.E. #	Cant.
18-3171	Bomba agua alojamiento	688-44311-01	1
18-3301	Chaveta	90280-04M04-00	1
18-3070	Impulsor	688-44352-03	1
18-0239	Junta	688-44315-A0-00	1
18-0240	Junta	688-44316-A0-00	1
18-7436	Aro	93210-46044-00	1

18-3372
KIT BOMBA DE AGUA
Sin alojamiento
Reemplaza: 6E5-W0078-01-00



— CONTIENE —

Ref #	Descripción	O.E. #	Cant.
18-3302	Chaveta	90280-04M05-00	1
18-3071	Impulsor	6E5-44352-00	1
18-3344	Platina impulsor	6E5-44323-00	1

18-3373
KIT BOMBA AGUA
Con alojamiento
Reemplaza: 6E5-W0078-A1-00



— CONTIENE —

Ref #	Descripción	O.E. #	Cant.
18-3170	Junta bomba alojamiento	6E5-44311-00-00	1
18-3302	Chaveta	90280-04M05-00	1
18-3071	Impulsor	6E5-44352-00	1
18-3344	Platina impulsor	6E5-44323-00	1
18-0244	Junta bomba combustible	6E5-44315-A0-00	1
18-0256	Tornillo	97395-08045-00	4
18-7483	Aro	93210-37M67-00	1
18-7485	Aro	93210-86M38-00	1

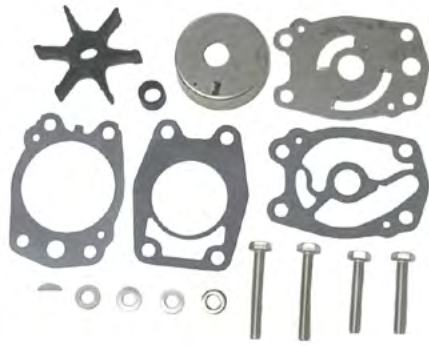

**18-3374
KIT BOMBA AGUA**

Sin alojamiento

Reemplaza: 6F5-W0078-00-00, 6F5-W0078-A0-00

-- CONTIENE --

Ref #	Descripción	O.E. #	Cant.
18-3300	Chaveta	90280-04M00-00	1
18-3088	Impulsor	6F5-44352-00	1
18-0256	Tornillo	97395-08045-00	2



**18-3398
KIT BOMBA AGUA**

Con alojamiento

Reemplaza: 6F5-W0078-A0-00, 6F5-W0078-00-00

-- CONTIENE --

Ref #	Descripción	O.E. #	Cant.
18-3088	Impulsor	6F5-44352-00	1
18-3300	Chaveta	90280-04M00-00	1
18-0256	Tornillo	97395-08045-00	2



**18-3395
KIT BOMBA AGUA**

Sin alojamiento

Reemplaza: 61A-W0078-01-00

-- CONTIENE --

Ref #	Descripción	O.E. #	Cant.
18-3071	Impulsor	6E5-44352-00	1
18-3345	Platina impulsor	6G5-44323-00	1
18-3302	Chaveta	90280-04M05-00	1
18-3333	Alojamiento impulsor	61A-44322-00	1
18-0244	Junta bomba de agua	6E5-44315-A0-00	1
18-0256	Tornillo	97395-08045-00	4
18-7483	Aro	93210-37M67-00	1
18-7485	Aro	93210-86M38-00	1



**18-3396-1
KIT BOMBA AGUA**

Con alojamiento

Reemplaza: 61A-W0078-A2-00, 61A-W0078-A3-00

-- CONTIENE --

Ref #	Descripción	O.E. #	Cant.
18-3173-1	Alojamiento bomba agua	61A-44311-00	1
18-3071	Impulsor	6E5-44352-00	1
18-3345	Platina impulsor	6G5-44323-00	1
18-3302	Chaveta	90280-04M05-00	1
18-3333	Alojamiento impulsor	61A-44322-00	1
18-0244	Junta bomba agua	6E5-44315-A0-00	1
18-0256	Tornillo	97395-08045-00	4
18-7483	Aro	93210-37M67-00	1
18-7485	Aro	93210-86M38-00	1



**18-3425
KIT BOMBA DE AGUA**

Sin alojamiento

Reemplaza: 663-W0078-00-00, 663-W0078-A0-00

-- CONTIENE --

Ref #	Descripción	O.E. #	Cant.
18-0292	Platina	663-44315-A0-00-00	1
18-3435	Alojamiento impulsor	663-44322-00-00	1
18-0294	Platina	663-44324-A0-00-00	1
18-3069	Impulsor	6H3-44352-00-00	1
18-0256	Tornillo	97395-08045-00	2
18-3436	Impulsor platina	663-44323-00-00	1
18-3297	Llave impulsor	90280-03M03-00	1



**18-3426
KIT BOMBA AGUA**

Con alojamiento

Reemplaza: 689-W0078-04-00, 689-W0078-A4-00

-- CONTIENE --

Ref #	Descripción	O.E. #	Cant.
18-3067	Impulsor	689-44352-02-00	1
18-3294	Llave impulsor	-	1



**18-3434
KIT BOMBA AGUA**

Sin alojamiento

Reemplaza: 63D-W0078-01-00, 63D-44311-00-00

Para: 40/50(1995-03),P40(1998), C40 3 cyl(1997-02), C50(1999-01),F40 2.6L(1999), F50(1995-03), P50 (1995-96), F60(2002-03)

Para kit con alojamiento, 18-3415



**18-3415
KIT BOMBA AGUA**

Con alojamiento

Reemplaza: 63D-W0078-01-00, 63D-44311-00-00

Para: 40/50(1995-03),P40(1998), C40 3 cyl(1997-02), C50(1999-01),F40 2.6L(1999), F50(1995-03), P50 (1995-96), F60(2002-03)

Para kit sin alojamiento, 18-3434



18-3440
KIT BOMBA AGUA
Sin alojamiento
Reemplaza: 66T-W0078-00-00
Para: T25 (2001-04), F30 (2001-04), F40 (2000-04)



18-3413
KIT BOMBA AGUA
Con alojamiento
Reemplaza: 66T-W0078-00, 66T-44311-00
Para: F30(2001-05), F40(2000-08), T25 (2001-06)
Para kit sin alojamiento, 18-3440

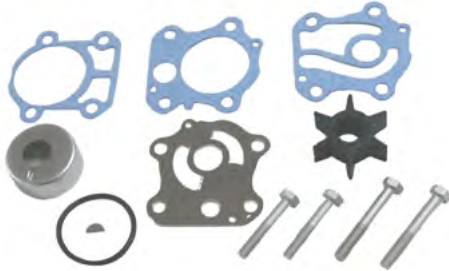

18-3428-1
KIT BOMBA AGUA
Sin alojamiento
Reemplaza: 6H3-W0078-00-00, 6H3-W0078-A0-00
-- CONTIENE --

Ref #	Descripción	O.E. #	Cant.
18-0240	Junta bomba agua	688-44316-A0-00	1
18-3069	Impulsor	6H3-44352-00-00	1
18-7436	Aro	93210-46044-00	1
18-0256	Tornillo	97395-08045-00	2
18-0756-1	Junta bomba agua	6H3-44315-A0-00	1
18-0757	Junta platina	6H3-44324-A0-00	1



18-3429
KIT BOMBA DE AGUA
Sin alojamiento
Reemplaza: 6H4-W0078-00-00, 6H4-W0078-A0-00
-- CONTIENE --

Ref #	Descripción	O.E. #	Cant.
18-0292	Junta montaje	688-44315-A0-00	1
18-3435	Alojamiento impulsor	663-44322-00-00	1
18-0294	Junta platina desgaste a base bomba	663-44324-A0-00	1
18-3068	Impulsor	6H4-44352-02-00, 6H4-44352-00-00	1
18-0256	Tornillo	97395-08045-00	2
18-3436	Impulsor platina	663-44323-00-00	1



18-3430
KIT REPARACIÓN BOMBA DE AGUA
Sin alojamiento
Reemplaza: 6J8-W0078-A1-00
-- CONTIENE --

Ref #	Descripción	O.E. #	Cant.
18-0292	Junta	688-44315-A0-00	1
18-3435	Alojamiento	663-44322-00-00	1
18-0294	Junta platina desgaste a bomba agua	663-44324-A0-00	1
18-3068	Impulsor	6H4-44352-02-00, 6H4-44352-00-00	1
18-0256	Tornillo	97395-08045-00	2
18-3436	Platina	663-44323-00-00	1



18-3431
KIT BOMBA AGUA
Sin alojamiento
Reemplaza: 6L2-W0078-00-00
-- CONTIENE --

Ref #	Descripción	O.E. #	Cant.
18-3065	Impulsor	6L2-44352-00-00	1
18-7483	Aro	93210-37M67-00	1



18-3427
KIT BOMBA AGUA
Con alojamiento
Reemplaza: 689-W0078-A6-00
-- CONTIENE --

Ref #	Descripción	O.E. #	Cant.
18-3294	Llave impulsor	—	1
18-3067	Impulsor	689-44352-02-00	1

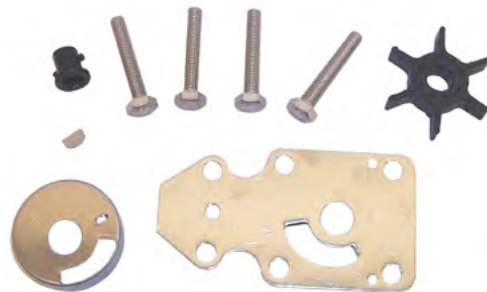

18-3433
KIT BOMBA AGUA
Sin alojamiento
Reemplaza: 63V-W0078-01-00
Para: 9.9/15(1996-04), F15 (1998-04)

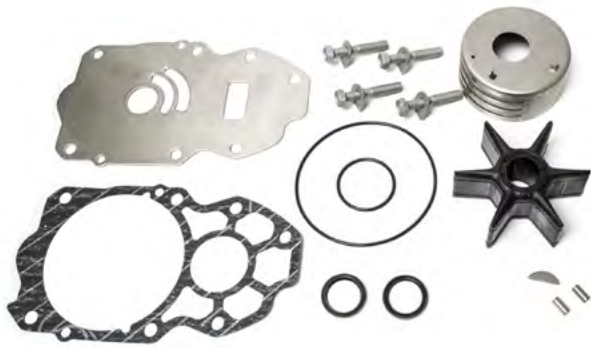

18-3470
KIT REPARACION BOMBA AGUA
Reemplaza: 6CE-W0078-01
Para: F225 (2010-15), F250 (2010), F250 (2010-15), F300 (2007-15), F350 (2007-15), FL250 (2010), FL300 (2010), FL350 (2010), LF225 (2010-15), LF250 (2010-15), LF300 (2007-15), LF350 (2007-15), VF250 (2015)



18-3471
KIT REPARACION BOMBA AGUA
Reemplaza: 6CE-W0078-01 + 6CE-44311-01
Para: F225 (2010-15), F250 (2010), F250 (2010-15), F300 (2007-15), F350 (2007-15), FL250 (2010), FL300 (2010), FL350 (2010), LF225 (2010-15), LF250 (2010-15), LF300(2007-15), LF350 (2007-15), VF250 (2015)

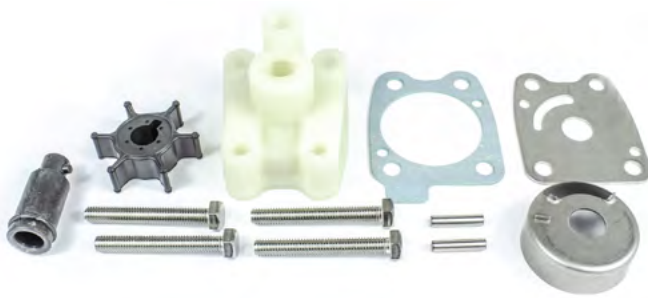

18-3473
KIT BOMBA AGUA
Reemplaza: 6 6EE-W0078-00-00
Para: F4 (2009-17), F6 (2009-17)



18-3474
KIT BOMBA AGUA
Reemplaza: CB-W0078-00-00
Para: VF225, VF250 (2009-18)



18-3475
KIT BOMBA AGUA
Reemplaza: 69G-W0078-00
Para: T9.9 (2007-17)



18-3477
KIT BOMBA AGUA
Reemplaza: 6AW-W0078-00-00
Para: F300, LF300 (2007-09)



18-3479
KIT BOMBA AGUA
Reemplaza: 6AH-W0078-00
Para: F15C, F20 (2006-17)



18-3490
KIT BOMBA AGUA
Reemplaza: 6BG-W0078-00-00
Para: F30 (2013-17), FD40A (2008-17)



18-3494
KIT BOMBA AGUA
Reemplaza: 6CJ-W0078-00-00
Para: F70A (2010-17)



18-4527

JUEGO BOMBA DE AGUA (sin alojamiento)

Reemplaza: 6FM-W0078-00-00

Para: F25C (2016-17)

- CONTIENE:

Referencia	Desc.	O.E.#	Cant.
18-4576	Placa de desgaste	6fm-44323-01	1
18-3486	Alojamiento bomba de agua	6l2-44311-01	1
18-4548	Inserto de copa	6l244322-00	1
18-9092	Placa	6l2-44328-00	2
18-3065	Impulsor	6l2-44352-00	1
18-1837	Amortiguador sello de agua 3	6l2-44367-10	1
18-3305	Llave de aspa (662)	90280-03024	1
18-71332	Junta tórica	93210-45161	1
18-43717	Pasador (688)	93604-10m03	2



18-4532

JUEGO BOMBA DE AGUA (sin alojamiento)

Reemplaza: 6EG-W0078-00-00

Para: F2.5 (2015-17)

- CONTIENE:

Referencia	Desc.	O.E.#	Cant.
18-1840	Amortiguador sello de agua 2	6ee-g4366-00	1
18-99157	Junta bomba de agua	6eg-g4315-00	1
18-4547	Inserto de copa	6eg-g4322-00	1
18-4574	Placa de desgaste	6eg-g4323-00	1
18-9089	Placa	6eg-g4328-00	2
18-8911	Impulsor	6l5-44352-00	1
18-43717	Pasador (688)	93604-10m03	2
18-8406	Tornillo con arandela	97595-06535	4



18-4533

JUEGO BOMBA DE AGUA (sin alojamiento)

Reemplaza: 65N-W0078-A0-00

Para: B115(1998-99), D150(1997-98), DX150(1999-05)

- CONTIENE:

Referencia	Desc.	O.E.#	Cant.
18-3519	Inserto de copa	61a-44322-02	1
18-0453	Junta bomba de agua	65n-44315-a0	1
18-0408	Placa de desgaste	65n-44323-00	1
18-3071	Impulsor	6e5-44352-01	1
NSS	Tornillo con arandela	90119-08m14	4
18-3302	Llave de aspa (6e5)	90280-04m05	1
18-7483	Junta tórica (6g8)	93210-37m67	1
18-7485	Junta tórica (6e5)	93210-86m38	1
NSS	Pasador (614)	93606-12019	2



18-4534

JUEGO BOMBA DE AGUA (SIN ALOJAMIENTO)

Reemplaza: 69M-WG078-00-00

Para: F2.5 (2003-15)

- CONTIENE:

Referencia	Desc.	O.E.#	Cant.
18-3166	Amortiguador sello de agua 2	6e0-44366-00	1
18-7119	Junta tórica	93210-33m85	1
18-3164	Inserto de copa	6l5-44322-00	1
18-8911	Impulsor	6l5-44352-00	1
18-0409	Placa de desgaste	69m-g4323-00	1
18-43716	Pasador	93604-18080	2
18-71330	Junta tórica	93210-05001	1
18-2607	Tornillo	97095-06040	4
18-9091	Placa	69m-g4328-00	1



MODELOS 4-TIEMPOS

HP MODEL	AÑO	IMPULSORES	CUP	LÁMINA	ALOJAMIENTO	SELLO AMORTIGUADOR	CUBIERTA BOMBA DE AGUA	KIT SIN CASCASA	KIT CON CASCASA
F2,5	2003-15	18-8911		18-0409		18-3166		18-4534	
F2,5	2016-18	18-8911	18-4547	18-4547		18-1840		18-4532	
4	1984-99	18-3073							
F4	1999-13	18-3073							
F4	2014-18	18-3073	18-4546	18-4573	18-4567	18-1840		18-3473	
F6	2001-08	18-8910	18-3444	18-3142	18-3356	18-3176		18-3450	18-3410
F6	2009-17	18-3073	18-4546	18-4573	18-4567			18-3473	
F8	2001-17	18-8910	18-3444	18-3142	18-3356	18-3176		18-3450	18-3410
T8	2001-10	18-3040	18-3444	18-3142	18-3356	18-3176		18-3450	18-3410
F9.9	1985-05	18-3074				18-1834		18-3148	18-3411
F9.9	2005-06	18-3040	18-3444	18-3195	18-3356	18-1833		18-3433	18-3412
F9.9	2007-17	18-8910	18-3444	18-3142	18-3356	18-3176		18-3450	18-3410
FT 9.9	1985-90	18-3074				18-1834		18-3148	18-3411
T9.9	1985-05	18-3074				18-1834		18-3148	18-3411
T9.9	2005-06	18-3040	18-3444	18-3195	18-3356	18-1833		18-3433	18-3412
T9.9	2007-17	18-3040	18-3444	18-3142	18-3356	18-3176		18-3475	
F15	1998-06	18-3040	18-3444	18-3195	18-3356	18-1833		18-3433	18-3412
F15C	2006-18	18-3040	18-3444	18-3142	18-3484	18-1836		18-3479	
F20	2006-18	18-3040	18-3444	18-3412	18-3484	18-1836		18-3479	
F25	1998-05	18-3068	18-3443	18-3194	18-3185				18-3432
F25A	2009-17	18-3068	18-3443	18-3194	18-3185				18-3432
F25B	2012-17	18-3068	18-3443	18-3194	18-3185				18-3432
F25C	2016-17	18-3065	18-4548	18-4576	18-3486	18-1837		18-4527	
T25	2001-06, 2009-17	18-3068	18-3449	18-3196				18-3443	18-3413
F30	2001-05	18-3068	18-3449	18-3196				18-3440	18-3413
F30	2013-17	18-3068	18-3449	18-3186		18-1828	18-9083	18-3490	18-3413
F40	1999	18-3069	18-3449	18-3186				18-3434	18-3415
F40	2000-06	18-3068	18-3449	18-3196				18-3440	18-3413
F40A	2008-17	18-3068	18-3449	18-3186		18-1828	18-9083	18-3490	18-3413
F40B	2007-08	18-3068	18-3449	18-3196				18-3440	18-3413
F50	1995-17	18-3069	18-3449	18-3486				18-3434	18-3415
F50	1996	18-3069	18-3435					18-3428-1	18-3461
F50	1997	18-3069	18-3435					18-3465	18-3466
T50	1996	18-3069	18-3435					18-3428-1	18-3461
T50	1997-17	18-3069	18-3435					18-3465	18-3466
F60	2002-17	18-3069	18-3449	18-3186				18-3434	18-3415
T60	2003-17	18-3069	18-3435					18-3465	18-3466
F70A	2010-17	18-3069	18-3449		18-3485			18-3494	
F75A	2003-17	18-3042	18-3162	18-31143		18-1830		18-3451	18-3409
F75B	2017	18-3071	18-3519	18-3521	18-3173-1	18-1835	18-9081	18-3442	18-3523-1
F80	1999-03	18-3042	18-3162	18-3143		18-1830		18-3451	18-3409
F90	2003-11	18-3042	18-3162	18-3143		18-1830		18-3451	18-3409
F90A	2012-17	18-3042	18-3162	18-3143		18-1830		18-3451	18-3409
F90B	2016-17	18-3071	18-3519	18-3521	18-3173-1	18-1835	18-9081	18-3442	18-3523-1

MODELOS 4-TIEMPOS

HP MODEL	AÑO	IMPULSORES	CUP	LÁMINA	ALOJAMIENTO	SELLO AMORTIGUADOR	CUBIERTA BOMBA DE AGUA	KIT SIN CARCASA	KIT CON CARCASA
VF90A	2018	18-3071	18-3519	18-3521	18-3173-1	18-1835	18-9081	18-3442	18-3523-1
F100	1999-03	18-3042	18-3162	18-3143		18-1830		18-3451	18-3409
F115/LF115	2000-01	18-3071	18-3333	18-3344	18-3173-1	18-1835	18-9081		18-3313-1
F115/LF115	2002-17	18-3071	18-3519	18-3521	18-3173-1	18-1835	18-9081	18-3442	18-3523-1
VF115	2015-17	18-3071	18-3519	18-3521	18-3173-1	18-1835	18-9081	18-3442	18-3523-1
F150/LF150	2004-11	18-3071	18-3519	18-3345	18-3173-1	18-1835	18-9081	18-3395	18-3396-1
F150A/LF150A	2012-14	18-3071	18-3519	18-3345	18-3173-1	18-1835	18-9081	18-3395	18-3396-1
F150B/LF150B	2015-18	18-3071	18-3519	18-3345	18-3173-1	18-1835	18-9081	18-3395	18-3396-1
F150C/LF150C	2017	18-3071	18-3519	18-3345	18-3173-1	18-1835	18-9081	18-3395	18-3396-1
VF150	2013-17	18-3071	18-3519	18-3345	18-3173-1	18-1835	18-9081	18-3395	18-3396-1
VF150AS	2018	18-3071	18-3519	18-3345	18-3173-1	18-1835	18-9081	18-3395	18-3396-1
F175A	2014-18	18-3071	18-3519	18-3345	18-3173-1	18-1835	18-9081	18-3395	18-3396-1
F175/LF175C	2017	18-3071	18-3519	18-3345	18-3173-1	18-1835	18-9081	18-3395	18-3396-1
VF175	2015-18	18-3071	18-3519	18-3345	18-3173-1	18-1835	18-9081	18-3395	18-3396-1
F200/LF200	2002-10	18-3071	18-3519	18-3345	18-3173-1	18-1835	18-9081	18-3395	18-3396-1
F200A/LF200A	2010-17	18-3071	18-3519	18-3345	18-3173-1	18-1835	18-9081	18-3395	18-3396-1
F200B/LF200B	2012-18	18-3071	18-3519	18-3345	18-3173-1	18-1835	18-9081	18-3395	18-3396-1
F200C/LF200C	2013-18	18-3071	18-3519	18-3345	18-3173-1	18-1835	18-9081	18-3395	18-3396-1
VF200	2009-18	18-3071	18-3519	18-3345	18-3173-1	18-1835	18-9081		
F225/LF225	2002-10	18-3071	18-3519	18-3345	18-3173-1	18-1835	18-9081	18-3395	18-3396-1
F225/LF225	2007-09	18-3071	18-3519	18-3518	18-3173-1	18-1835	18-9081	18-3395	
F225A/LF225A(3.3L)	2011-17	18-3071	18-3519	18-3345	18-3173-1	18-1835	18-9081	18-3395	18-3396-1
F225A/LF225A(4.2L)	2010-17	18-45617-1	18-3457	18-3549	18-3482	18-1829	18-9082	18-3470	18-3471
F225B/LF225B(4.2L)	2016-17	18-45617-1	18-3457	18-3459	18-3482	18-1829	18-9082	18-3470	18-3471
F225B/LF225B(3.3L)	2016-17	18-3071	18-3519	18-3345	18-3173-1	18-1835	18-9081	18-3395	18-3396-1
VF225(4.2L)	2009-18	18-3071	18-3519		18-3173-1	18-1835	18-9081	18-3774	
F250/LF250(3.3L)	2005	18-3071	18-3519	18-3345	18-3173-1	18-1835	18-9081	18-3395	18-3396-1
F250/LF250(3.3L)	2006-11	18-3071	18-3519	18-3518	18-3173-1	18-1835	18-9081	18-3615	
F250A/LF250A(3.3L)	2010-17	18-3071	18-3519	18-3518	18-3173-1	18-1835	18-9081	18-3515	
F250A/LF250A(4.2L)	2014-17	18-45647-1	18-3457	18-3459	18-3482	18-1829	18-9082	18-3470	18-3471
F250B/LF250B(3.3L)	2008-09	18-3071	18-3519	18-3518	18-3173-1	18-1835	18-9081	18-3515	
F250B/LF250B(4.2)	2016-17	18-45617-1	18-3457	18-3459	18-3482	18-1829	18-9082	18-3470	18-3471
FL250	2010	18-45617-1	18-3457	18-3459	18-3482	18-1829	18-9082	18-3470	18-3471
VF250	2009-18	18-3071	18-3519		18-3173-1	18-1835	18-9081	18-3474	
VF250(XA Moldes)	2015-18	18-45617-1	18-3457	18-3459	18-3482	18-1829	18-9082	18-3470	18-3471
F300/LF300(5.3I)	2007-09	18-8925	18-3457	18-0421	18-3483	18-1835	18-9081	18-3477	
F300/LF300(4.2L)	2010-18	18-45617-1	18-3457	18-3459	18-3482	18-1829	18-9082	18-3470	18-3471
FL300	2010,2016	18-45617-1	18-3457	18-3459	18-3482	18-1829	18-9082	18-3470	18-3471
F350/LF350(5.3L)	2007-09	18-8925	18-3457	18-0421	18-3483	18-1835	18-9081	18-3477	
F350A/LF350A(5.3L)	2010-11	18-8925	18-3457	18-0421	18-3483	18-1835	18-9081	18-3477	
F350B/LF350B(5.3L)	2012-15	18-8925	18-3457	18-0421	18-3483	18-1835	18-9081	18-3477	
F350C/LF350C(5.3L)	2016-18	18-8925	18-3457	18-0421	18-3483	18-1835	18-9081	18-3477	
FL350(5.3L)	2010	18-8925	18-3457	18-0421	18-3483	18-1835	18-9081	18-3477	

MODELOS 2-TIEMPOS

HP\Modelo	Año	Impulsor	Impulsor aloj.	Platina	Alojamiento	Kit con alojamiento	Kit sin alojamiento
2	1984-87	18-3072	18-3328	18-3357	—	18-3463	—
2	1988-02	18-3072	18-3328	18-3357	—	18-3462	—
4	1984-99	18-3073				—	—
5	1984-02	18-3073				—	—
6	1986-00	18-3066	18-3456		—	—	18-3460
8	1984-09	18-3066	18-3456		—	—	18-3460
9.9	1984-95	18-3074				18-3411	18-3148
9.9	1996-09	18-3040	18-3444	18-3195		18-3412	18-3433
15	1984-95	18-3074				18-3411	18-3148
15	1996-09	18-3040	18-3444	18-3195		18-3412	18-3433
20	1996-97	18-3065			—	—	18-3431
25	1984-85	18-3067				18-3426	—
25	1986-87	18-3067				18-3427	—
25 (2 cil)	1988-09	18-3065			—	—	18-3431
25 (3 cil)	1996-02	18-3068	—	—	—	—	—
C25	1990-97	18-3067				18-3427	—
CV25	1990	18-3067				18-3427	—
30	1984-85	18-3067				18-3426	—
30	1986	18-3067				18-3427	—
30	1987-01	18-3068	18-3435	18-3436	—	—	18-3430
C30	1990-92	18-3067				18-3427	—
C30	1993-97	18-3068	18-3443	18-3194	18-3185	18-3432	—
40	1984-87	18-3068	18-3435	18-3436	—	18-3408	18-3429
40	1988-94	18-3068	18-3435	18-3436	—	—	18-3429
40	1995-05	18-3069	18-3449	18-3186		18-3415	18-3434
C40	1990-91	18-3088	—	—	—	18-3375	18-3374
C40	1992-97	18-3088	—	—	—	18-3398	18-3397
C40	1997-03	18-3069	18-3449	18-3186		18-3415	18-3434
P40	1998	18-3069	18-3449	18-3186		18-3415	18-3434
50	1984-87	18-3068	18-3435	18-3436	—	18-3408	18-3429
50	1988-94	18-3068	18-3435	18-3436	—	—	18-3429
50	1995-09	18-3069	18-3449	18-3186		18-3415	18-3434
C50	1998-01	18-3069	18-3449	18-3186		18-3415	18-3434
PRO 50	1987	18-3068	18-3435	18-3436	—	18-3408	18-3429
PRO 50	1988-90	18-3068	18-3435	18-3436	—	—	18-3429
P50	1991-93	18-3068	18-3435	18-3436	—	—	18-3429
P50	1995-96	18-3069	18-3449	18-3186		—	18-3434
50 Jet	1986-89	18-3068	—	—	—	—	—
C55	1991-94	18-3069	18-3435	18-3436	—	—	18-3425
CV55	1989	18-3069	18-3435	18-3436	—	—	18-3425
60	2001-03	18-3069	18-3435	—	—	—	18-3465
60	2004-05	18-3070	—	—	18-3171	18-3371	18-3370
C60	1996-01	18-3069	18-3435	—	—	18-3466	18-3465
E60	1995-96	18-3069	18-3435	—	—	18-3466	18-3465
E60	1997-00	18-3069	—	—	—	—	—
P60	1991	18-3069	18-3435	—	—	18-3461	18-3428-1
P60	1992-99	18-3069	18-3435	—	—	18-3466	18-3465
70	1984-91	18-3069	18-3435	—	—	18-3461	18-3428-1
70	1992-03	18-3069	18-3435	—	—	18-3466	18-3465
70	2004-09	18-3070	—	—	18-3171	18-3371	18-3370
C70	2000-01	18-3069	18-3435	—	—	18-3466	18-3465
C75	1994-99	18-3070	—	—	18-3171	18-3371	18-3370
E75	1995-00	18-3070	—	—	—	—	—
P75	1996-99	18-3070	—	—	—	—	—
C80	1997	18-3070	—	—	—	—	—
85	1985	18-3070	—	—	—	—	—
C85	1989-97	18-3070	—	—	18-3171	18-3371	18-3370
CV85	1989-91	18-3070	—	—	18-3171	18-3371	18-3370
90	1984-09	18-3070	—	—	18-3171	18-3371	18-3370
90 Jet	1986-89	18-3070	—	—	—	—	—
B90	1997-99	18-3070	—	—	—	—	—

① 2.6L motor ② 3.1L motor * modelos con eje 20" ** excluye 4.2L

MODELOS 2-TIEMPOS

HP/Modelo	Año	Impulsor	Impulsor aloj.	Platina	Alojamiento	Kit con alojamiento	Kit sin alojamiento
C90	1997-01	18-3070	—	—	18-3171	18-3371	18-3370
C115	1991-92	18-3071	—	18-3344	18-3170	18-3373	18-3372
C115	1993-96	18-3071	18-3333	18-3344	18-3173-1	18-3313-1	18-3312
C115	1997-00	18-3071	—	18-3344	—	—	—
P115 (62A)	1993-96	18-3071	18-3333	18-3344	18-3173-1	18-3313-1	18-3312
115 (6N6), (6E5)	1984-94	18-3071	—	18-3344	18-3170	18-3373	18-3372
115 (6N6)	1994	18-3071	18-3333	18-3344	18-3173-1	18-3313-1	18-3312
130 (6L1), (6N7)	1988-92	18-3071	—	18-3344	18-3170	18-3373	18-3372
130 (6N7)	1993-96	18-3071	18-3333	18-3344	18-3173-1	18-3313-1	18-3312
130	1997-01	18-3071	—	18-3344	—	—	—
130	2002-04	—	—	18-3344	—	—	—
L130 (6L6), (6N4)	1989-92	18-3071	—	18-3344	18-3170	18-3373	18-3372
L130 (6N4)	1993-96	18-3071	18-3333	18-3344	18-3173-1	18-3313-1	18-3312
L130	1997-01	18-3071	—	18-3344	—	—	—
C150 (6E5)	1996-99	18-3071	18-3333	18-3345	18-3173-1	18-3396-1	18-3395
150 (6R2), (6G4)	1984-91	18-3071	—	18-3344	18-3170	18-3311	18-3310
150 (6R2)	1992-09	18-3071	18-3333	18-3345	18-3173-1	18-3396-1	18-3395
L150 (6R0), (6K0)	1986-91	18-3071	—	18-3344	18-3170	18-3311	18-3310
L150 (6R0)	1992-99	18-3071	18-3333	18-3345	18-3173-1	18-3396-1	18-3395
P150	1986-91	18-3071	—	18-3344	18-3170	18-3311	18-3310
P150	1992-99	18-3071	18-3333	18-3345	18-3173-1	18-3396-1	18-3395
150/175/200ETLN	1984	18-3071	—	18-3344	18-3170	18-3311	18-3310
PRO V150 (6J9)	1986-89	18-3071	—	18-3344	18-3170	18-3311	18-3310
PRO V150D (6N9)	1990	18-3071	—	18-3344	18-3170	18-3311	18-3310
PX150	1999	18-3071	18-3333	18-3345	18-3173-1	18-3396-1	18-3395
SX150	1999-04	18-3071	18-3333	18-3345	18-3173-1	18-3396-1	18-3395
V150	2000-08	18-3071	18-3333	18-3345	18-3173-1	18-3396-1	18-3395
VZ150	2001-09	18-3071	18-3333	18-3345	18-3173-1	18-3396-1	18-3395
Z150/LZ150	2001-05	18-3071	18-3333	18-3345	18-3173-1	18-3396-1	18-3395
175 (6G5)	1984-91	18-3071	—	18-3344	18-3170	18-3311	18-3310
175 (6R3)	1992-00	18-3071	18-3333	18-3345	18-3173-1	18-3396-1	18-3395
P175 (62H)	1994-99	18-3071	18-3333	18-3345	18-3173-1	18-3396-1	18-3395
VZ175	2001-09	18-3071	18-3333	18-3345	18-3173-1	18-3396-1	18-3395
Z175	2001-05	18-3071	18-3333	18-3345	18-3173-1	18-3396-1	18-3395
200 (6G6), (6R4)	1984-91	18-3071	—	18-3344	18-3170	18-3311	18-3310
200 (6R4)	1992-99	18-3071	18-3333	18-3345	18-3173-1	18-3396-1	18-3395
L200 (6K1), (6R1)	1986-91	18-3071	—	18-3344	18-3170	18-3311	18-3310
L200	1992-99	18-3071	18-3333	18-3345	18-3173-1	18-3396-1	18-3395
LX200	1999-02	18-3071	18-3333	18-3345	18-3173-1	18-3396-1	18-3395
P200	1991-99	18-3071	18-3333	18-3345	18-3173-1	18-3396-1	18-3395
SX200	1999-05	18-3071	18-3333	18-3345	18-3173-1	18-3396-1	18-3395
V200	1998-99	18-3071	18-3333	18-3345	18-3173-1	18-3396-1	18-3395
VZ200	2001-04	18-3071	18-3333	18-3345	18-3173-1	18-3396-1	18-3395
VZ200	2005-09	18-3071	18-3519	18-3520	18-3173-1	—	18-3516
Z200/LZ200	2000-10	18-3071	18-3333	18-3345	18-3173-1	18-3396-1	18-3395
V6 Special (6G7)	1984-86	18-3071	—	18-3344	18-3170	18-3311	18-3310
V6 Excel (6K7)	1987-89	18-3071	—	18-3344	18-3170	18-3311	18-3310
225 (6R5)	1990-91	18-3071	—	18-3344	18-3170	18-3311	18-3310
225 ^①	1992-97	18-3071	18-3333	18-3345	18-3173-1	18-3396-1	18-3395
225/L225/S225 ^②	1994-99	18-3071	18-3333	18-3345	18-3173-1	18-3396-1	18-3395
LX225/SX225	2000-03	18-3071	18-3333	18-3345	18-3173-1	18-3396-1	18-3395
V225	1998-99	18-3071	18-3333	18-3345	18-3173-1	18-3396-1	18-3395
VX225	2000-04	18-3071	18-3333	18-3345	18-3173-1	18-3396-1	18-3395
VZ225	2003-09	18-3071	18-3519	18-3520	18-3173-1	—	18-3516
250/L250	1990-96	18-3071	18-3333	18-3345	18-3173-1	18-3396-1	18-3395
L250/S250	1997-99	18-3071	18-3333	18-3345	18-3173-1	18-3396-1	18-3395
VX250	2002-04	18-3071	18-3333	18-3345	18-3173-1	18-3396-1	18-3395
VZ250	2003-09	18-3071	18-3519	18-3520	18-3173-1	—	18-3516
Z300	2006	18-3071	18-3519	—	18-3173-1	—	18-3515
LZ300	2006	18-3071	18-3519	—	18-3173-1	—	18-3515
VZ300	2004-09	18-3071	18-3519	18-3520	18-3173-1	—	18-3516

① 2.6L motor

② 3.1L motor

* modelos con eje 20"

** excluye 4.2L

NEW



**18-3524
TERMOSTATO**

Reemplaza: 6CE-12411-00-00
Para: F225/LF225 (2010-2016), F250/LF250 (2010-2016), VF250 (2015), F300/LF300 (2010-2016), FL250/FL300 (2010)

50°C



**18-3525
TERMOSTATO**

Reemplaza: 60V-12411-00
Para: F115(2005-14), LF115(2005-14), LZ250(2003-05), LZ300(2004-06), VZ200(2005-09), VZ225(2005-09), VZ250(2005-09), VZ300(2005-09), Z250(2003-05), Z300(2004-06)

60°C



**18-3625
TERMOSTATO**

(Retén incluido)
Reemplaza: 6F5-12411-03-00
9.9EL, 9.9ES, 15EL, 15ES (1986-1995), 9.9L, 9.9S, 15L, 15S (1986-1990), 9.9M, 15ML, 15MS, C55EL (1991-1995), C25EL, C40EL (1991-1997), C25ML (1993-1997), C25MS, C40MS, C40PL (1992-1997), C30EL (1991-1992), CV30EL (1989-1990), C40ML (1994-1995), C55TL (1993-1995), CV25EL, CV25EM, CV40EL (1990), CV55EL (1989)

50°C



**18-3623
TERMOSTATO**

(Retén Incluido)
Reemplaza: 6E5-12411-02-00
8MSH-0405, 8MSH-0406, 8MSH-0407, 8MSH-0608, 8MSHD-2005

60°C



**18-3632
TERMOSTATO**

Reemplaza: 67F-12411-01-00
Para: F75-F250 (2005 & Sup)

50°C



**18-3540
TERMOSTATO**

Reemplaza: 6E5-12411-30-00
Para: 9.9-15 (1996-06), 20 (1996-97), 25 (1988-95), 30 3-cyl (1987-91), 40 (1986-05), C40 3-cyl (1998-02), 50 (1986-05), C50 (1998-01), P50 (1987-96), 115 (1984-05), B115 (1998-99), C115 (1991-00), P115 (1993-96), S115/S130 (1996-98), 130/L130 (1988-05), 150/175/200 (1986-05), C150 (1996-99), D150/DX150 (1997-05), L150/L200 (1986-99), LX150/LX200 (1999-01), P150 (1986-99), PX150 (1999), SX150/SX200 (1999-04), V150 (2000-05), VX150 (2000-05), VZ150/VZ175/VZ200 (2001-05), Z150/Z175/Z200 (2000-05), P200 (1991-93), V200/V225 (1998-99), VX200/VX225 (2000-05), V6 Special (1984-86), V6 Excel (1987-89), 225 2.6L (1990-97), 250/L250 2.6L (1990-95)
Nota: No encajarán 3.1 L

60°C



**18-3541
TERMOSTATO**

Reemplaza: 66M-12411-01-00
Para: F6 (2001-05), F8 (2001-05), T8 (2001-05), F9.9 (1985-05), T9.9 (1985-05), T9.9 (1991-05), F15 (1998-05), F25 (1998-05), T25 (2001-05), F30 (2001-05), F40 4 cil. (1999), F40 3 cil. (2000-05), F50 (1995-05), T50 (1996-05), F60 (2002-05), T60 (2003-05), F80 (1999-00), F100 (1999-00)

50°C



**18-3622
KIT TERMOSTATO**

Reemplaza: 6H3-12411-11-00
60TLR-0405, 70TLR-0405, 70TLR-0406, 70TLR-0407, 70TLR-0408

50°C



**18-3624
KIT TERMOSTATO**

Reemplaza: 69M-12411-01-00
F2.5MSH-0405, F2.5MSH-0406, F2.5MSH-0407, F2.5MSH0608, F2.5MSHD-2005

① 18-3608D



**18-3608
KIT TERMOSTATO**

Para: 115 (1991-02), C115 (1991-99), P115 (1993-96), S115 (1996-99), 130 (1991-02), L130 (1991-00), S130 (1996-99), 150 (1991-02), C150 (1996-99), L150 (1991-99), P150 (1991-99), S150 (1996-99), V150 (2000-02), Z150 (2001-02), 175 (1991-95, 97), P175 (1994-99), V175 (2000), Z175 (2001-02), 200 (1991-98), L200 (1991-99), P200 (1991-99), S200 (1996-99), V200 (1998-99), Z200 (2001-02), 225 (1991-97), V225 (1998-99)

— CONTIENE —

Ref #	Descripción	O.E. #	Cant.
18-3540	Termostato	6E5-12411-30-00	1
18-0844	Junta	688-12414-A1-00	1

① 18-3609D



**18-3609
KIT TERMOSTATO**

Para: 25 (1996-98, 2001-02), 40 (1991-99, 01), C40 (1997-02), P40 (1998), 50 (1991-97, 1999-02), C50 (1998-01), P50 (1991-96), L225 (1994-99), S225 (1996-99), 250 (1991-95), L250 (1991-99), S250 (1996-99)

— CONTIENE —

Ref #	Descripción	O.E. #	Cant.
18-3540	Termostato	6E5-12411-30-00	1
18-0829	Junta	61A-12414-A0-00, 6J8-12414-A0-00	1

60°C



**18-3611
KIT TERMOSTATO**

Para: 15 (2006), F15 (1998-06), F25 (1999-06), F30 (2001-06), F40 (1999-06), F50 (1996-06), F60 (2002-06), F9.9 (2005-06), T25 (2001-06), T50 (1996-06), T60 (2003-06), T9.9 (2005-06)

① Referencias acabadas en "D" envasadas en display

APLICACIONES TERMOSTATO EN LA SIGUIENTE PÁGINA

APLICACIÓN TERMOSTATO 2 TIEMPOS

HPModelo	Año	Termostato	Junta	Kit termostato	HPModelo	Año	Termostato	Junta	Kit termostato
F2.5	2003-11	Kit sólo	18-0754	18-3624	E75	1995-00	—	18-0844	—
4	1986-88	18-3540	—	—	P75	1996-99	—	18-0844	—
4	1989-99	18-3623	—	—	C80	1997	—	18-0844	—
F4	1999-11	18-3541	18-0754	—	F80	1999-00	18-3541	—	—
5	1995-02	18-3623	—	—	90	1984-09	—	18-0844	—
6	1986-88	18-3540	—	—	90 Jet	1986-00	—	18-0844	—
6	1989-00	18-3623	—	—	B90	1997-99	—	18-0844	—
F6	2001-04	18-3541	—	—	C90	1997-01	—	18-0844	—
F6	2005-08	18-3541	—	—	F100	1999-00	18-3541	—	—
F6	2009-11	18-3541	18-0754	—	115	1984-09	18-3540	18-0844	18-3608
8	1986-88	18-3540	—	—	B115	1998-99	18-3540	18-0844	18-3608
8	1989-09	18-3623	—	—	C115	1991-00	18-3540	18-0844	18-3608
F8	2001-04	18-3541	—	—	P115	1993-96	18-3540	18-0844	18-3608
F8	2005-11	18-3541	—	—	S115	1996-99	18-3540	18-0844	18-3608
T8	2001-04	18-3541	—	—	130	1988-04	18-3540	18-0844	18-3608
T8	2005-10	18-3541	—	—	L130	1989-01	18-3540	18-0844	18-3608
9.9	1986-95	18-3625	18-0836	—	S130	1996-99	18-3540	18-0844	18-3608
9.9	1996-09	18-3540	18-0836	—	C150	1996-99	18-3540	18-0844	18-3608
F9.9	1985-11	18-3541	—	—	150	1984	—	18-0844	—
FT9.9	1985-90	18-3541	—	—	150	1985	18-3623	18-0844	—
T9.9	1991-04, 2007-11	18-3541	—	—	150	1986-09	18-3540	18-0844	18-3608
T9.9	2005-06	18-3541	18-0835	18-3611	D150	1997-99	18-3540	18-0844	18-3608
15	1984-85	—	18-0836	—	DX150	1999-05	18-3540	18-0844	18-3608
15	1986-95	18-3625	18-0836	—	L150	1986-99	18-3540	18-0844	18-3608
15	1996-09	18-3540	18-0836	—	LX150	1999-01	18-3540	18-0844	18-3608
F15	1998-06	18-3541	18-0835	18-3611	LZ150	2000-05	18-3540	18-0844	18-3608
20	1996-97	18-3540	18-0829	18-3609	Z150	2000-05	18-3540	18-0844	18-3608
25 (2 cil)	1984-87	—	18-0232	—	P150	1991-99	18-3540	18-0844	18-3608
25 (2 cil)	1988-09	18-3540	18-0829	18-3609	PX150	1999	18-3540	18-0844	18-3608
C25	1991-97	18-3625	18-0232	—	PRO V150	1986-90	18-3540	18-0844	18-3608
CV25	1990	18-3625	18-0232	—	S150	1996-99	18-3540	18-0844	18-3608
F25	1998-11	18-3541	18-0835	18-3611	SX150	1999-04	18-3540	18-0844	18-3608
T25	2001-11	18-3541	18-0835	18-3611	V150	2000-08	18-3540	18-0844	18-3608
30	1984-85	—	18-0232	—	VX150	2000-04	18-3540	18-0844	18-3608
30	1986	18-3625	18-0835	—	VZ150	2000-11	18-3540	18-0844	18-3608
30	1987-88	18-3540	18-0829	18-3609	175	1984	—	18-0844	—
30	1989-91	18-3623	18-0829	—	175	1985	18-3623	18-0844	—
30	1992-02	—	18-0829	—	175	1986-00	18-3540	18-0844	18-3608
C30	1991-92	18-3625	18-0232	—	P175	1994-99	18-3540	18-0844	18-3608
C30	1993-94, 1996-97	18-3623	18-0232	—	S175	1996-99	18-3540	18-0844	18-3608
F30	2001-05	18-3541	18-0835	18-3611	V175	2000	18-3540	18-0844	18-3608
40	1984-85	—	18-0829	—	VZ175	2001-10	18-3540	18-0844	18-3608
40	1986-05	18-3540	18-0829	18-3609	Z175	2001-05	18-3540	18-0844	18-3608
C40	1991-97	18-3625	—	—	200	1984	—	18-0844	—
C40	1998-03	18-3540	18-0829	18-3609	200	1985	18-3623	18-0844	—
F40	1999-11	18-3541	18-0835	18-3611	200	1986-98	18-3540	18-0844	18-3608
F40 2.6L	1999	18-3541	18-0835	18-3611	L200	1986-99	18-3540	18-0844	18-3608
P40	1998	18-3540	18-0829	18-3609	LX200	1999-01	18-3540	18-0844	18-3608
50	1984-85	—	18-0829	—	LZ200	2000-11	18-3540	18-0844	18-3608
50	1986-09	18-3540	18-0829	18-3609	P200	1991-99	18-3540	18-0844	18-3608
C50	1998-01	18-3540	18-0829	18-3609	SX200	1999-05	18-3540	18-0844	18-3608
F50	1995-11	18-3541	18-0835	18-3611	V200	1998-99	18-3540	18-0829	18-3609
PRO 50	1987-90	18-3540	18-0829	18-3609	VX200	2000-05	18-3540	18-0829	18-3609
P50	1991-96	18-3540	18-0829	18-3609	VZ200	2001-04	18-3540	18-0844	18-3608
50 Jet	1986-00	18-3540	18-0829	18-3609	Z200	2000-11	18-3540	18-0844	18-3608
T50	1996-11	18-3541	18-0835	18-3611	V6 Special	1985-86	18-3540	18-0844	18-3608
C55	1991-95	18-3625	—	—	V6 Excel	1987-89	18-3540	18-0844	18-3608
CV55	1989-90	18-3625	—	—	225	1990-97	18-3540	18-0844	18-3608
60	2001-05	Kit sólo	18-0835	18-3622	L225	1994-99	18-3540	18-0829	18-3609
C60	1996-01	Kit sólo	18-0835	18-3622	S225	1996-99	18-3540	18-0829	18-3609
E60	1995-00	Kit sólo	18-0835	18-3622	LX225	2000-03	18-3540	18-0829	18-3609
F60	2002-11	18-3541	18-0835	18-3611	SX225	2000-03	18-3540	18-0829	18-3609
P60	1991-99	Kit sólo	18-0835	18-3622	V225	1998-99	18-3540	18-0829	18-3609
T60	2003-11	18-3541	18-0835	18-3611	VX225	2000-04	18-3540	18-0829	18-3609
70	1984-09	Kit sólo	18-0835	18-3622	250	1990-95	18-3540	18-0829	18-3609
C70	2000-01	Kit sólo	18-0835	18-3622	L250	1990-99	18-3540	18-0829	18-3609
F70	2010	18-3541	18-0835	18-3611	LX250	2000-03	18-3540	18-0829	18-3609
C75	1994-99	—	18-0844	—	S250	1996-99	18-3540	18-0829	18-3609
					SX250	2000-03	18-3540	18-0829	18-3609
					VX250	2002-04	18-3540	18-0829	18-3609

APLICACIONES CONTINÚAN EN LA SIGUIENTE PÁGINA

APLICACIÓN DEL TERMOSTATO DE 4 TIEMPOS YAMAHA

HP/Model	AÑO	TERMOSTATO	JUNTA	KIT TERMOSTATO	CANT. POR MOTOR
F2.5	2003-17	Kit only	18-0754	18-3624	1
F4	1999-17	18-3541	18-0754		1
F6	2001-08	18-3541	18-99120		1
F6	2009-17	18-3541	18-0754		1
F8	2001-10	18-3541	18-99120		1
F8A	2011-14	18-3541	18-99120		1
F8B	2015-18	18-3541	18-99120		1
T8	2001-10	18-3541	18-99120		1
F9.9	1985-05	18-3541	18-99120		1
F9.9(66N)	2005-06	18-3541	18-0835	18-3611	1
F9.9A	2011-12	18-3541	18-99120		1
F9.9B	2013-18	18-3541	18-99120		1
F9.9F	2007-10	18-3541	18-99120		1
FT9.9	1985-90	18-3541	18-99120		1
T9.9	1991-05	18-3541	18-99120		1
T9.9(66R)	2005-06	18-3541	18-0835	18-3611	1
T9.9A	2011-12	18-3541	18-99120		1
T9.9B	2013-18	18-3541	18-99120		1
T9.9G	2007-10	18-3541	18-99120		1
F15	1998-06	18-3541	18-0835	18-3611	1
F25	1998-05	18-3541	18-0835	18-3611	1
F25A	2009-18	18-3541	18-0835	18-3611	1
F25B	2012-18	18-3541	18-0835	18-3611	1
F25	1998-08	18-3541	18-0835	18-3611	1
T25	2001-04	18-3541	18-0835	18-3611	1
T25	2001-08	18-3541	18-0835	18-3611	1
T25	2009-18	18-3541	18-0835	18-3611	1
F30	2001-05	18-3541	18-0835	18-3611	1
F30	2013-18	18-3541	18-0835	18-3611	1
F40	1999-06	18-3541	18-0835	18-3611	1
F40A	2008-18	18-3541	18-0835	18-3611	1
F40B	2007-08	18-3541	18-0835	18-3611	1
F50	1995-18	18-3541	18-0835	18-3611	1
T50	1996-18	18-3541	18-0835	18-3611	1
F60	2002-18	18-3541	18-0835	18-3611	1
T60	2003-18	18-3541	18-0835	18-3611	1
F70A	2010-18	18-3541	18-0835	18-3611	1
F75A	2003-17	18-3632			1
F75B	2017-18	18-3641			1
F80	1999-00	18-3541			1
F80	2001-03	18-3632			1
F90	2003-11	18-3632			1

APLICACIONES CONTINÚAN EN LA SIGUIENTE PÁGINA

APLICACIÓN DEL TERMOSTATO DE 4 TIEMPOS YAMAHA

HP/Model	AÑO	TERMOSTATO	JUNTA	KIT TERMOSTATO	CANT. POR MOTOR
F90A	2012-17	18-3632			1
F90B	2016-18	18-3641			1
VF90A	2018	18-3641			1
F100	1999-00	18-3541			1
F100	2001-03	18-3632			1
F115/LF115	2000-14	18-3525			1
F115/LF115	2014-18	18-3639			1
VF115	2015-18	18-3639			1
F150/LF150	2004-11	18-3632	18-99127		1
F150A/LF150A	2012-14	18-3632	18-99127		1
F150LF150BF150C/ LF150C	2015-18	18-3632	18-99127		1
VF150	2013-17	18-3636			1
VF150A	2018	18-3636			1
F175A	2014-18	18-3636			1
F175C/LF175C	2017	18-3636			1
VF175	2015-18	18-3636			1
F200/LF200	2005-10	18-3636			2
F200A/LF200A	2011-17	18-3632			2
F200B/LF200B	2012-18	18-3632			1
F200C/LF200C	2013-18	18-3636			1
VF200	2009-10	18-3636			2
VF200LA	2011-18	18-3632			2
F225/LF225	2005-10	18-3637			2
F225A/LF225A	2011-17	18-3632			2
F225A/LF225A	2010-17	18-3632			2
F225B/LF225B	2016-17	18-3524			2
F225B/LF225B	2008-09	18-3524			2
VF225	2009-10	18-3632			2
VF225LA	2011-18	18-3632			2
F250/LF250	2005-11	18-3637			2
F250A/LF250A	2010-17	18-3632			2
F250B/LF250B	2016-17	18-3524			2
VF250	2010	18-3524			2
VF250LA	2011-18	18-3632			2
VF250XA	2015-17	18-3637			2
F300/LF300	2007-09	18-3524			2
F300A/LF300A	2010-18	18-3634			2
F350/LF350	2007-09	18-3524			2
F350A/LF350A	2010-11	18-3634			2
F350B/LF350B	2012-15	18-3634			2
F350C/LF350C	2016-18	18-3634			2

**TODOS LOS PISTONES
TODOS LOS PISTONES SE SUMINISTRAN CON AROS, BULÓN Y CIERRES**



Aros pistón disponibles individualmente.

V-4 & V-6 Pistones y aros

STANDARD			.25mm O.S.		.50mm O.S.	
18-4128 (babor) Reemplaza: 6G5-11642-00-93	18-4129 (Estr.) Reemplaza: 6G5-11631-00-93	— CONTIENE —	18-4130 (babor)		18-4132 (babor) Reemplaza: 6G5-11646-01-00	18-4133 (Estr.) Reemplaza: 6G5-11636-01-00
Ref #	Aros	O.E. #				
18-3934	Standard	6E5-11610-03-00				

MOTORES V-6 (1992-2001)

18-4080 (babor) Reemplaza: 6R5-11642-11-93	18-4081 (Estr.) Reemplaza: 6R5-11631-11-93	— CONTIENE —	18-4082 (babor) Reemplaza: 6R5-11645-11-00	18-4083 (Estr.) Reemplaza: 6R5-11635-11-00	18-4084 (babor) Reemplaza: 6R5-11646-11-00	18-4085 (Estr.) Reemplaza: 6R5-11636-11-00
Ref #	Aros	O.E. #				
18-39320	Standard	6R5-11603-00				

★ ★ **Aros y pistones en línea** ★ ★

STANDARD			.25mm O.S.		.50mm O.S.	
18-4091 Reemplaza: 6H3-11631-01-96 — CONTIENE —			18-3977 Reemplaza: 682-11610-11-00		18-4096 Reemplaza: 6K511636-03-00	
Ref #	Aros	O.E. #	18-4145 Reemplaza: 61N-11635-00-00		18-4146 Reemplaza: 61N-11636-00-00	
18-3963	Standard	6K5-11601-02-00			— CONTIENE —	
18-4135 Reemplaza: 6E7-11631-00-97 — CONTIENE —			18-4142 Reemplaza: 6H4-11635-01-00		18-4099 Reemplaza: 6H1-11636-03-00	
Ref #	Aros	O.E. #	18-3958 Reemplaza: 61N-11604-00-00 — CONTIENE —			
18-3976	Standard	682-11610-01-00				
18-4138 Reemplaza: 689-11631-00-95 — CONTIENE —						
Ref #	Aros	O.E. #				
18-3954	Standard	689-11610-01-00				
18-4141 Reemplaza: 6H4-11631-00-96 — CONTIENE —						
Ref #	Aros	O.E. #				
18-3960	Standard	6H4-11610-00-00				
18-4097 Reemplaza: 6H1-11631-03-95 — CONTIENE —						
Ref #	Aros	O.E. #				
18-3969	Standard	688-11603-A0-00				

APLICACIÓN PISTONES

HP/Modelo	Años	PISTONES			AROS		
		Std.	.25mm	.50mm	Std.	.25mm	.50mm
9.9/15	1984-96	18-4135	—	18-4137	18-3976	18-3977	—
9.9/15	1997-2009	18-4135	—	18-4137	18-3976	18-3977	—
25	1985	18-4138	—	—	18-3954	—	—
30	1984-86	18-4138	—	—	18-3954	—	—
C30	1991-92	18-4138	—	—	18-3954	—	—
C30	1993-97	—	18-4145	18-4146	—	18-3961	—
40	1984-88	18-4141	—	—	18-3960	18-3961	18-3962
C40	1997-99,2001-02	—	18-4142	—	18-3960	18-3961	18-3962
P40	1998	—	—	—	18-3960	18-3961	18-3962
E48	1997	18-4097	—	18-4099	18-3969	—	—
50	1984-88	18-4141	—	—	18-3960	—	18-3962
50	1996-97, 1999, 2000,2002-03	18-4141	18-4142	—	18-3960	18-3961	18-3962
C50	1998-99, 2001	—	18-4142	—	18-3960	18-3961	18-3962
P50	1996	—	18-4142	—	18-3960	18-3961	18-3962
Pro50	1987-88	18-4141	—	—	18-3960	—	—
60	2001-05	18-4091	—	—	18-3963	—	—
C60	1996-01	18-4091	—	—	18-3963	—	—
E60 MLH,T,U,V	1995-00	—	—	18-4096	18-3963	—	—
P60	1991-99	18-4091	—	—	18-3963	—	—
70	1984-09	18-4091	—	—	18-3963	—	—
C70	2000-01	18-4091	—	—	18-3963	—	—
75	1994-98	18-4097	—	18-4099	18-3969	—	—
C75	1996	18-4097	—	18-4099	18-3969	—	—

APLICACIONES CONTINUAN EN LA SIGUIENTE PÁGINA



APLICACIÓN PISTON (Cont.)

HP/Modelo	Años	Estr.	PISTON		Estr.	AROS	
			.25mm	.50mm		.25mm	.50mm
C75	1998-99	18-4097	—	18-4099	18-3969	—	—
E75	1996-97	18-4097	—	18-4099	18-3969	—	—
P75	1996-99	18-4097	—	18-4099	18-3969	—	—
C80	1997	18-4097	—	18-4099	18-3969	—	—
C85	1996	18-4097	—	18-4099	18-3969	—	—
90	1994-09	18-4097	—	18-4099	18-3969	—	—
C90	1997-01	18-4097	—	18-4099	18-3969	—	—

V4 & V-6 Motores		Años	PISTON						AROS
			babor Std.	Estr. Std.	babor .25mm	Estr. .25mm	babor .50mm	Estr. .50mm	Std.
115 con/22mm pasador	V-4	1984-86	18-4128	18-4129	18-4130	—	18-4132	18-4133	18-3934
115 con/22mm pasador	V-4	1987-92	18-4128	18-4129	18-4130	—	18-4132	18-4133	18-3934
115 con/23mm pasador	V-4	1993-03	18-4080	18-4081	18-4082	18-4083	18-4084	18-4085	18-39320
130 con/22mm pasador	V-4	1984-92	18-4128	18-4129	18-4130	—	18-4132	18-4133	18-3934
130 con/23mm pasador	V-4	1993-03	18-4080	18-4081	18-4082	18-4083	18-4084	18-4085	18-39320
150, 175 con/22mm pasador	V-6	1984-92	18-4128	18-4129	18-4130	—	18-4132	18-4133	18-3934
150, 175 con /23mm pasador	V-6	1993-99	18-4080	18-4081	18-4082	18-4083	18-4084	18-4085	18-39320
200, 225 con/22mm pasador	V-6	1984-92	18-4128	18-4129	18-4130	—	18-4132	18-4133	18-3934
200, 225 con/22mm pasador	V-6	1993-99	18-4080	18-4081	18-4082	18-4083	18-4084	18-4085	18-39320
ESPECIAL J,K,LN,XN (6G7)	V-6	1984-86	18-4128	18-4129	18-4130	—	18-4132	18-4133	18-3934

 <p>18-1755 BIELA Reemplaza: 650-11651-04-00 Para: 9.9, 15 (1996-97)</p>	 <p>18-1756 BIELA Reemplaza: 688-11650-03-00 Para: 55 (1991-95), 75 (1994-99), 80 (1997), 85 (1991-96), 90 (1997, 2000-01)</p>	 <p>18-1755K KIT BIELA Reemplaza: 650-11651-04-00 Para: E336 9.9 (1996-97), 15 (1996-97)</p>	 <p>18-4157 BIELA Reemplaza: 6R5-11650-10-00 Para: V6 150/175/200 (1992-03)</p>	 <p>18-1410 COJINETE Reemplaza: 93310-32337-00 Para: 115 (1993-03), 130 (1993-00, 2002-03), 150 (1992-00, 2002-03), 175 (1992-98, 2000), 200 (1992-98), 225 (1992-93, 1997)</p>
--	--	--	--	---

 <p>18-1411 COJINETE Reemplaza: 93310-620V5-00 Para: 9.9 (1996-97), 15 (1996-97)</p>	 <p>18-4077 COJINETE Reemplaza: 93310-730V8-00 Para: 45, 55, 90 HP -3 Cil.</p>	 <p>18-4078 COJINETE Reemplaza: 93310-836V2-00 Para: V4 & V6 (1990 motores)</p>	 <p>18-0191 ARANDELA Reemplaza: 92990-06600-00</p> <p>18-0192 Reemplaza: 92990-10600-00, 929-90106-00-00, 92900-10600-00, 92901-10600-00, 92902-10600-00, 92903-10600-00, 92995-10600-00</p>	 <p>18-79974 FILTRO ACEITE Reemplaza: 6J8-13411-00 Para: 20(1996-97), 25(1988-01), 30(1987-02), 40(1989-05), 50(1989-09), 60(2001-05), 70(1989-09), C30(1995), P40(1998), P50(1991-96), P60(1991-99), PRO50(1989-90)</p>
--	--	---	---	--

 <p>18-79975 FILTRO ACEITE Reemplaza: 6E5-13411-00 Para: 115(1988-09), 130(1988-05), 150(1989-09), 175(1989-00), 200(1989-98), 225(1990-97), B115(1988-99), D150(1997-99), DX150(1999-05), L130(1989-01), L150(1988-99), L200(1988-99), LX150(1999-01), LX200(1999-01), LZ150(2000-05), LZ200(1999-12), P115(1993-96), P150(1991-99), P175(1994-99), P200(1991-99), PRO V150(1988-90), PX150(1999), S115-(1996-99), S130(1996-99), S150(1996-99), S200(1996-99)SX150(1999-04), SX200(1999-05), V150(2000-08), V175(2000), V6 Excel(1988-89), VX150(2000-04), VZ150(2000-12), VZ175(2001-12), VZ200(2001-04), Z150(2000-05), Z175(2001-05), Z200(2000-12)</p>	 <p>18-79976 FILTRO ACEITE Reemplaza: 61A-13411-00 Para: 225(1994-95), 250(1990-95), L225(1994-99), L250(1990-99), LX225(2000-03), LX250(2000-03), LZ250(2003-05), LZ300(2004-06), S225(1996-99), S250(1996-99), SX225(2000-03), SX250(2000-03), V200(1998-99), V225(1998-99), VX200(2000-05), VX225(2000-04), VX250(2002-04), VZ200(2005-09), VZ225(2003-09), VZ250(2003-09), VZ300(2004-09), Z250(2003-05), Z300(2004-06)</p>
--	--

 <p>18-79971 FILTRO ACEITE, ELECTRICO Reemplaza: 68F-13440-00 Para: LZ150(2000-05), LZ200(2000-12), LZ250(2003-05), LZ300(2004-06), VZ150(2000-12), VZ175(2001-12), VZ175(2001-12), VZ200(2001-09), VZ225(2003-09), VZ250(2003-09), VZ300(2004-09), Z150(2000-05), Z175(2001-05), Z200(2000-12), Z250(2003-05), Z300(2004-06)</p>	 <p>18-79961 FILTRO ACEITE Reemplaza: 6H1-13411-00 Para: 90(1990-01), B90(1997-99), C90(2000-01), P75(1996-99)</p>	 <p>18-7911-1 1879111E Easterner FILTRO ACEITE Reemplaza: 5GH-13440-00, 5GH-13440-10, 5GH-13440-30</p>	 <p>18-7954 187954E Easterner FILTRO ACEITE Reemplaza: N26-13440-00-00 Para: F350</p>
---	--	---	---



18-8700
188700E Easterner
FILTRO ACEITE
 Reemplaza: 5GH-13440-20, 5JW-13400-00-00, 2MB-E3440-00-00, 1WD-E3440-00-00
 Para: F15(2006-12), F20(2006-12), F25(2009-12), F40(2008-12), F50(2005-12), F60(2005-12), F70(2010-12), T25(2009-12), T50(2005-12), T60(2005-12)



18-2456
TORNILLO DRENAJE
 Reemplaza: 90340-14M06-00.
 Para: 15-350HP. 1995-2018.



**FILTRO ACEITE
 4-CICLO FUERABORDA**

Modelo	Año	Reemplaza	Ref.
F/T9.9	1990-03	6G8-13440-00-00	18-7901
F/T50	1995-99	3FV-13440-00-00	18-7902
F15,F25	1998-99	3FV-13440-00-00	18-7902
F80/F100	1999	3FV-13440-00-00	18-7902
F40	1999-00	3FV-13440-00-00	18-7902
F200/F225	2002-06	69J-13440-00-00, -01-00, -03-00	18-7906-1
F150	2004-06	69J-13440-00-00, -01-00, -03-00	18-7906-1
F250	2005-06	69J-13440-00-00, -01-00, -03-00	18-7906-1
F350	2008-up	N26-13440-00-00	18-7954

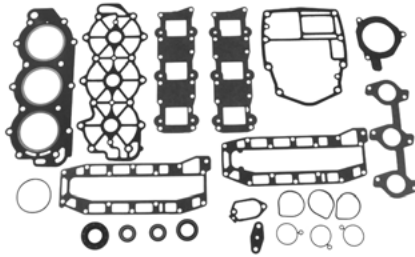

18-99061
JUEGO JUNTAS
 Reemplaza: 63D-W0001-00
 Para: 40(1995-05), 50(1995-069), C40(1997-02), C50(1998-01), P40(1998), P50(1995-96)



18-99073
JUEGO JUNTAS
 Reemplaza: 65W-W0001-20
 Para: F25(1998-00)

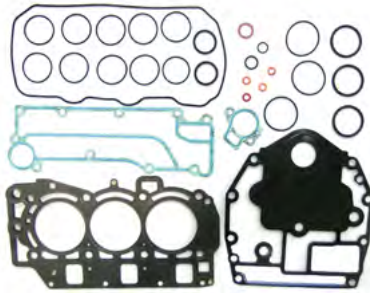

18-99092
JUEGO JUNTAS
 Reemplaza: 67C-W0001-00
 Para: F30(2001), F40(2000-01)

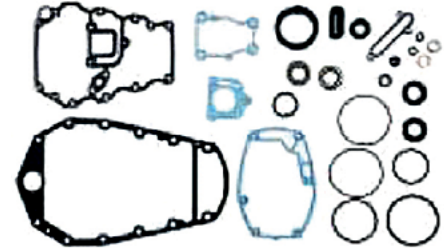

18-99093
JUEGO JUNTAS
 Reemplaza: 67C-W0001-20
 Para: F30(2001), F40(2000-01), T25(2001)

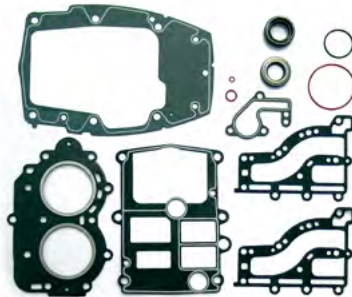

18-99097
JUEGO JUNTAS
 Reemplaza: 682-W0001-06
 Para: 9.9(1994-95), 15(1994-95)

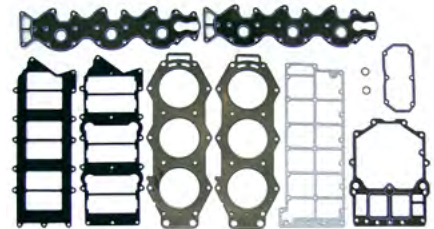

18-99103
JUEGO JUNTAS
 Reemplaza: 68F-W0001-01
 Para: LZ150(2004-05), LZ200(2004-10), VZ150(2004-10), VZ175(2004-10), VZ200(2004), Z150(2004-05), Z175(2004-05), Z200(2004-10)

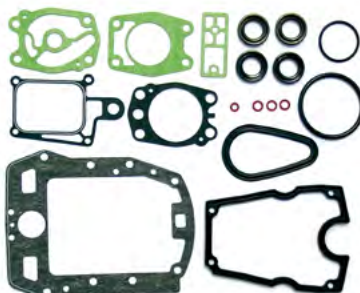

18-99104
JUEGO JUNTAS
 Reemplaza: 6A0-W0001-21
 Para: C40(1992-94)

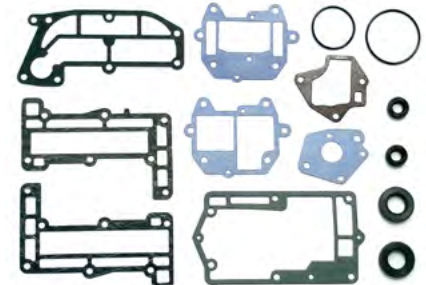

18-99117
JUEGO JUNTAS
 Reemplaza: 6G1-W0001-A2
 Para: 6(1996), 8(1996)

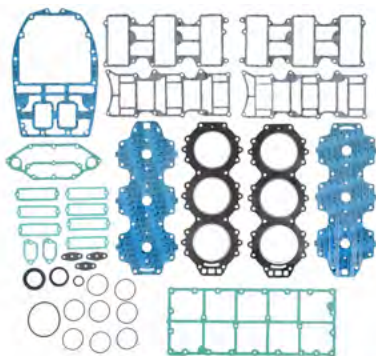

18-4400

JUEGO DE JUNTAS BLOQUE DE MOTOR

Reemplaza: 61A-W0001-01-00, 61A-W0001-A1-00

— CONTIENE —

Ref #	Descripción	O.E. #	Cant.
18-3891	Junta culata	61A-11181-00-A0	2
18-0829	Aro	61A-12414-A0-00, 6J8-12414-A0-00	2
18-0808	Junta válvula presión	6G5-11382-A1-00	1

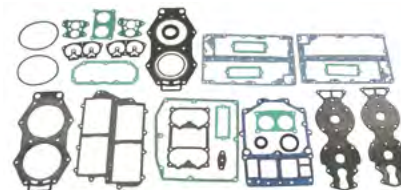

18-4403

JUEGO JUNTAS BLOQUE MOTOR

Reemplaza: 6F3-W0001-04-00, 6F3-W0001-A4-00

— CONTIENE —

Ref #	Descripción	O.E. #	Cant.
18-3832	Junta culata	6E5-11181-02-00	2
18-0844	Junta tapa termostato	688-12414-A1-00	2
18-2079	Retén aceite	93101-22M15-00	1
18-2085	Retén aceite	93102-35M13-00	1
18-7442	Aro	93210-74M35-00	1
18-7444	Aro	93211-04384-00	2
18-0782	Junta tapa	6E5-11381-A1-00	1
18-0799	Junta tapa escape	6E5-41112-A1-00	2
18-0823	Junta colector escape	6E5-13645-A1-00	1
18-0785	Junta montaje carburador	6E5-14198-A1-00	2
18-0813	Junta base	6G5-45113-A0-00	1
18-2592	Junta flotador	6E5-14384-03-00	2
18-0781	Junta tapa agua	6E5-11193-A0-00	2

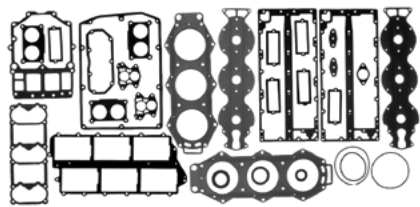

18-4404

JUEGO JUNTAS BLOQUE MOTOR

Reemplaza: 6G5-W0001-03-00, 6G5-W0001-A3-00

— CONTIENE —

Ref #	Descripción	O.E. #	Cant.
18-3894	Junta culata	6G5-11181-A0-00	2
18-0844	Junta tapa termostato	688-12414-A1-00	2
18-2079	Retén aceite	93101-22M15-00	1
18-2085	Retén aceite	93102-35M13-00	1
18-7442	Aro	93210-74M35-00	1
18-7444	Aro	93211-04384-00	2
18-0785	Junta montaje carburador	6E5-14198-A1-00	3
18-0808	Junta válvula presión	6G5-11382-A1-00	1
18-0813	Junta base	6G5-45113-A0-00	1
18-0782	Junta tapa	6E5-11381-A1-00	1
18-0809	Junta bloque	6G5-13645-A1-00	1
18-0812	Junta tapa escape	6E5-41112-A1-00	2
18-0779	Junta tapa agua	6G5-11193-A0-00	2

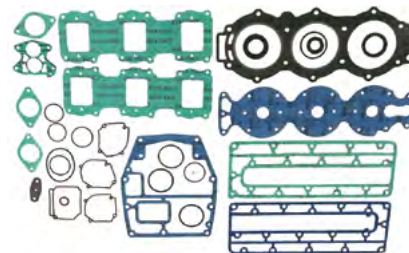

18-4405

JUEGO DE JUNTAS BLOQUE MOTOR

Reemplaza: 6H1-W0001-00-00, 6H1-W0001-01-00, 6H1-W0001-A0-00

— CONTIENE —

Ref #	Descripción	O.E. #	Cant.
18-3805	Junta culata	688-11181-02-00	1
18-0840-1	Aro	676-14984-00-00	3
18-0844	Junta tapa termostato	688-12414-A1-00	1
18-0847	Junta tapa escape	688-41112-A0-00	1
18-0826	Junta tornillo drenaje	90430-14115-00	1
18-7436	Aro	93210-46044-00	3
18-0767	Junta Tapa Agua	688-11193-01-00	1

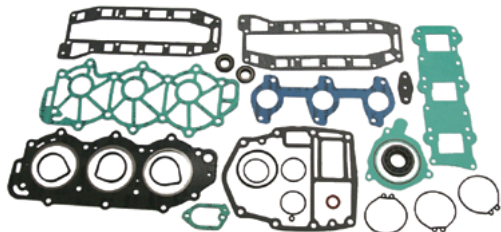

18-4407

JUEGO JUNTAS BLOQUE MOTOR

Reemplaza: 6H4-W0001-01-00, 6H4-W0001-A1-00

— CONTIENE —

Ref #	Descripción	O.E. #	Cant.
18-3830	Junta culata	6H4-11181-00-00	1
18-0826	Junta tornillo drenaje	90430-14115-00	1
18-0815	Junta tapa agua	6H4-11193-A1-00	1
18-0798	Junta tapa escape	6H4-41114-A0-00	1
18-0829	Junta tapa	61A-12414-A0-00, 6J8-12414-A0-00	1

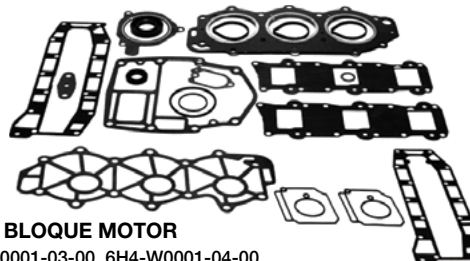

18-4409

JUEGO JUNTAS BLOQUE MOTOR

Reemplaza: 6H4-W0001-03-00, 6H4-W0001-04-00

— CONTIENE —

Ref #	Descripción	O.E.#	Cant.
18-3830	Junta culata	6H4-11181-00-00	1
18-0826	Junta tornillo drenaje	90430-14115-00	1
18-7432	Aro	93210-32768-00	1
18-0815	Junta tapa agua	6H4-11193-A1-00	1
18-0798	Junta tapa escape	6H4-41114-A0-00	1
18-0829	Junta tapa	61A-12414-A0-00, 6J8-12414-A0-00	1

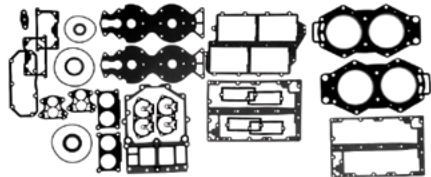

18-4411

JUEGO JUNTAS BLOQUE MOTOR

Reemplaza: 6N6-W0001-03-00, 6N6-W0001-A3-00

— CONTIENE —

Ref #	Descripción	O.E. #	Cant.
18-3832	Junta culata	6E5-11181-02-00	2
18-0844	Junta tapa termostato	688-12414-A1-00	2
18-2079	Retén aceite	93101-22M18-00	1
18-2085	Retén aceite	93102-35M13-00	1
18-7442	Aro	93210-74M35-00	1
18-7444	Aro	93211-04384-00	2
18-0782	Junta tapa	6E5-11381-A1-00	1
18-0799	Junta tapa escape	6E5-41112-A1-00	2
18-0823	Junta colector escape	6E5-13645-A1-00	1
18-0785	Junta montaje carburador	6E5-14198-A1-00	2
18-0813	Junta base	6G5-45113-A0-00	1
18-2592	Junta flotador	6E5-14384-03-00	2
18-0781	Junta tapa agua	6E5-11193-A0-00	2

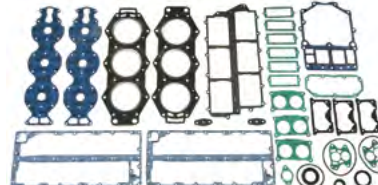

18-4412

JUEGO JUNTAS BLOQUE MOTOR

Reemplaza: 6R3-W0001-03-00, 6R3-W0001-A3-00

— CONTIENE —

Ref #	Descripción	O.E. #	Cant.
18-3894	Junta culata	6G5-11181-A0-00	2
18-0844	Junta tapa termostato	688-12414-A1-00	2
18-2079	Retén aceite	93101-22M18-00	1
18-2085	Retén aceite	93102-35M13-00	1
18-7442	Aro	93210-74M35-00	1
18-7444	Aro	93211-04384-00	2
18-0782	Junta tapa	6E5-11381-A1-00	1
18-0809	Junta bloque	6G5-13645-A1-00	1
18-0812	Junta tapa escape	6G5-41112-A1-00	2
18-0779	Junta tapa agua	6G5-11193-A0-00	2
18-0785	Junta montaje carburador	6E5-14198-A1-00	3
18-0808	Junta válvula presión	6G5-11382-A1-00	1
18-0816	Junta base	6G5-45113-A0-00	1

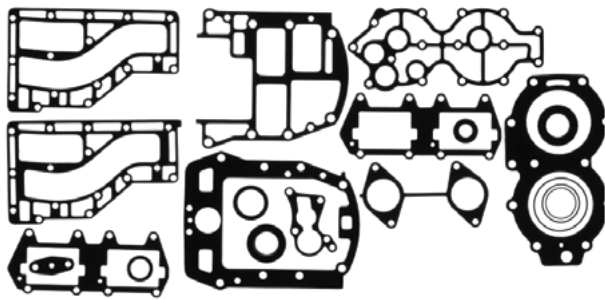

18-4413
JUEGO JUNTAS BLOQUE MOTOR

Reemplaza: 6R6-W0001-01-00

— CONTIENE —

Ref #	Descripción	O.E. #	Cant.
18-3892	Junta culata	676-11181-00-A0	1
18-7126	Aro	—	1

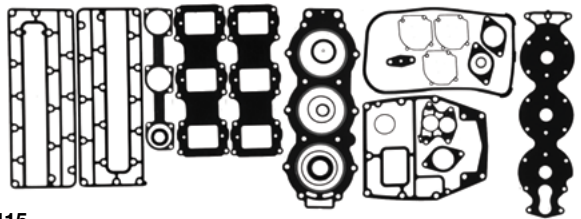

18-4415
JUEGO JUNTAS BLOQUE MOTOR

Reemplaza: 688-W0001-00-00, 688-W0001-A0-00

— CONTIENE —

18-0840	Retén cazoleta comb	676-14984-00-00	3
18-3805	Junta culata	688-11181-02-00	1
18-0844	Junta tapa termostato	688-12414-A1-00	1
18-0846	Junta montaje carburador	688-14198-A1-00	3
18-0847	Junta tapa escape	688-41112-A0-00	2
18-0826	Junta tornillo drenaje	90430-14115-00-00	1
18-0767	Junta	688-11193-01-00	1
18-0845	Junta platina colector admisión	688-13621-A1-00	2
18-7441	Aro	93210-62269-00	1

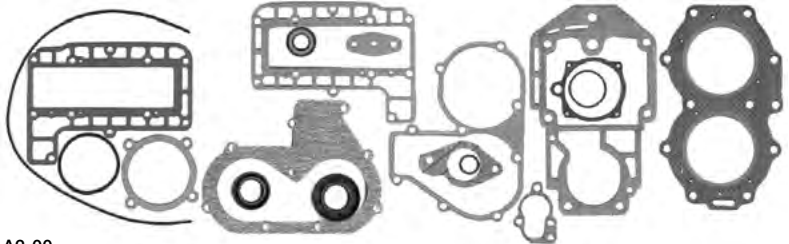

18-4417
JUEGO JUNTAS BLOQUE MOTOR

Reemplaza: 695-W0001-01-00, 695-W0001-02-00, 695-W0001-A2-00

— CONTIENE —

Ref #	Descripción	O.E. #	Cant.
18-0231	Junta	648-13621-A1-00	1
18-0771	Junta colector admisión	648-13645-A0-00	1
18-0775	Junta montaje carburador	648-14198-A0-00	1
NSS	Junta	648-14384-01-00	1
18-0232	Junta tapa	655-12414-A1-00	1
18-0250	Junta tapa escape	664-41114-A0-00	2
18-2078	Retén aceite	93101-16M36-00	1
18-0570	Retén aceite	93102-23096-00	1
18-3849	Junta culata	695-11181-A0-00	1
18-0739	Junta superior	689-45113-A1-00	1

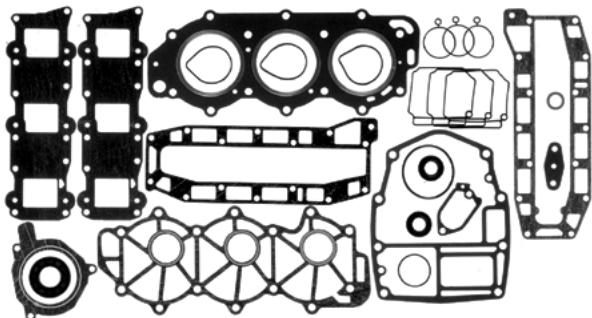

18-4419
JUEGO JUNTAS BLOQUE MOTOR

Reemplaza: 6H4-W0001-02-00, 6H4-W0001-A2-00

— CONTIENE —

Ref #	Descripción	O.E. #	Cant.
18-3830	Junta culata	6H4-11181-00-00	1
18-0826	Junta tornillo drenaje	90430-14115-00-00	1

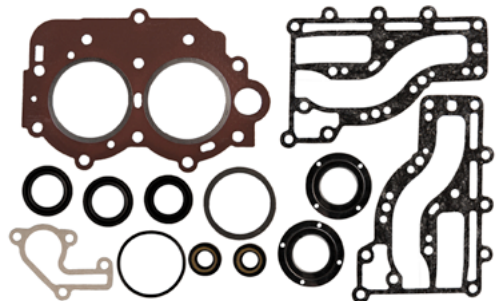

18-99175
JUEGO JUNTAS BLOQUE MOTOR

Reemplaza: 63V-W0001-00, 63V-W0001-01

Para: 9.9(1996-00), 15(1996-00)

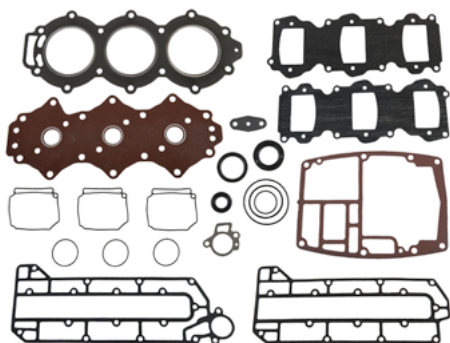

18-99176
JUEGO JUNTAS BLOQUE MOTOR

Reemplaza: 6H3-W0001-02

Para: 60(2001-05), 70(1994-09), C70(2000-01), P60(1994-99)

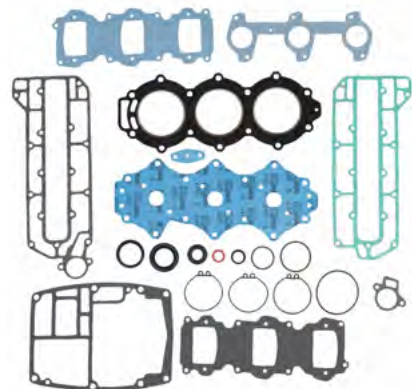

18-4427
JUEGO JUNTAS BLOQUE MOTOR

Reemplaza: 6H3-W0001-A0-00

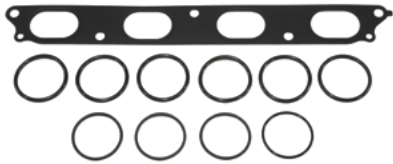

18-0663
KIT DE JUNTAS
 Para: Yamaha F75 (2003-04), F80 (1999-03), F90 (2003-04), F100 (1999-02)



18-99048
JUNTA CULATA
 Reemplaza: 60V-11181-00
 Para: LZ250(2003-05), VZ200(2005-09), VZ225(2003-09), VZ250(2003-09), Z250(2003-05)

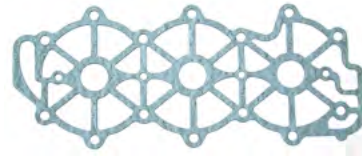

18-99059
JUNTA CULATA
 Reemplaza: 63D-11193-A0
 Para: 40(1995-05), 50(1995-09), C40(1997-03), C50(1998-01), P40(1998), P50(1995-96)



18-99060
JUNTA CULATA
 Reemplaza: 63D-11181-A1
 Para: 40(1997-05), 50(1997-08), C40(1997-03), C50(1998-01), P40(1998)



18-99062
JUNTA CULATA
 Reemplaza: 68F-11181-00
 Para: LZ150(2000-05), LZ200(2000-10), VZ150(2000-10), VZ175(2001-10), VZ200(2001-04), Z150(2000-05), Z175(2001-05), Z200(2000-10)

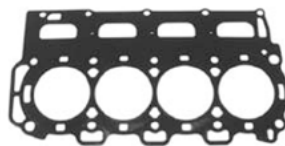

18-99094
JUNTA CULATA
 Reemplaza: 67F-11181-02
 Para: F75(2004-05), F90(2004-05), F115(2004-05), LF115(2004-05)



18-3804
JUNTA CULATA
 Reemplaza: 689-11181-02-00, 689-W0001-A1-00



18-3805
JUNTA CULATA
 Reemplaza: 688-11181-02-00, 688-11181-A1-00



18-3827
JUNTA CULATA
 Reemplaza: 6G8-11181-00-00, 6G8-11181-A1-00



18-3828
JUNTA CULATA
 Reemplaza: 6E7-11181-00-00, 6E7-11181-A1-00



18-3829
JUNTA CULATA
 Reemplaza: 6J8-11181-00-00, 6J8-11181-A1-001



18-3830
JUNTA CULATA
 Reemplaza: 6H4-11181-00-00, 6H4-11181-A1-00



18-3831
JUNTA CULATA
 Reemplaza: 6H3-11181-01-00, 6H3-11181-A1-00



18-3832
JUNTA CULATA
 Reemplaza: 6E5-11181-02-00, 6E5-11181-A1-00



18-3847
JUNTA CULATA
 Reemplaza: 6L2-11181-A1-00, 6L2-11181-A2-00



18-3848
JUNTA CULATA
 Reemplaza: 697-11181-A0-00, 697-11181-A1-00



18-3849
JUNTA CULATA
 Reemplaza: 695-11181-A0-00, 695-11181-A1-00



18-3891
JUNTA CULATA
 Reemplaza: 61A-11181-A0-00, 61A-11181-A1-00



18-3892
JUNTA CULATA
 Reemplaza: 676-11181-A0-00, 676-11181-A1-00



18-3894
JUNTA CULATA
 Reemplaza: 6G5-11181-00-00, 6G5-11181-A0-00

JUEGO JUNTAS BLOQUE MOTOR \ APLICACIÓN JUNTA CULATA

HP	Año	Juego juntas bloque motor	Junta Culata	HP	Año	Juego juntas bloque motor	Junta Culata
6	1988-96	18-99117		F80	1999-01		18-99094
8	1984-96	18-99117		F80	2002-03		18-99094
9.9	1984-87		18-3828	C85	1991	18-4415	18-3805
9.9	1988-91		18-3828	C85	1992-93		18-3805
9.9	1992-93		18-3828	C85	1994-96		18-3805
9.9	1994-95		18-3828	CV85	1989-90	18-4415	18-3805
9.9	1996	18-99175		90	1984-93	18-4405	18-3805
9.9	1997-00	18-99175	18-99140	90	1994-09		18-3805
9.9	2001-08		18-99140	B90	1997-99		18-3805
F9.9	1986-89		18-3827	C90	1997-01		18-3805
F9.9	1990-05		18-3827	F90	2003-04		18-99094
FT9.9	1985-87		18-3827	F90	2005-11		18-99094
FT9.9	1988-89		18-3827	F100	1999-01		18-99094
FT9.9	1990		18-3827	F100	2002-03		18-99094
T9.9	1991-05		18-3827	115	1984		18-3832
15	1984-87		18-3828	115	1985		18-3832
15	1988-91		18-3828	115	1986 1		18-3832
15	1992-93		18-3828	115	1986-89 2	18-4403	18-3832
15	1994-95	18-99097		115	1990-99	18-4411	18-3832
15	1996	18-99175		115	2000-01		18-3832
15	1997-00	18-99175	18-99140	115	2002-09		18-3832
15	2001-08		18-99140	B115	1998-99		18-3832
20	1996-97		18-3847	C115	1991-95	18-4403	18-3832
25 (2 cil)	1984-87		18-3804	C115	1996-99		18-3832
25 (2 cil)	1988-93	18-4422	18-3847	C115	2000		18-3832
25 (2 cil)	1994-09		18-3847	F115	2000-01		18-99094
25 (3 cil)	1997-02		18-3829	F115	2002-05		18-99094
C25	1991-93	18-4417	18-3849	F115	2006-11		18-99094
C25	1994-97		18-3849	LF115	2000-01		18-99094
CV25	1990	18-4417	18-3849	LF115	2002-05		18-99094
F25	1998-01	18-99073		LF115	2006-11		18-99094
30	1984-86		18-3804	P115	1993-96	18-4411	18-3832
30	1987-94		18-3829	S115	1996-99	18-4411	18-3832
30	1993-02		18-3829	130	1988-99	18-4403	18-3832
C30	1991-92		18-3804	130	2000-01		18-3832
C30	1995-97		18-3829	130	2002-04		18-3832
CV30	1989-90		18-3804	L130	1989	18-4403	18-3832
F30	2000	18-99093		L130	1990-99	18-4411	18-3832
F30	2001-05	18-99092		L130	2000-01		18-3832
40	1984-88	18-4407	18-3830	S130	1996-99	18-4411	18-3832
40	1989-91	18-4419	18-3830	150	1984-89	18-4404	18-3894
40	1992-94	18-4409	18-3830	150	1990-95	18-4412	18-3894
40	1995-05	18-99061	18-99060	150	1996-03		18-3894
C40 2 Cil	1991		18-3892	150	2004-09		18-3894
C40 2 Cil	1992-93	18-4413	18-3892	C150	1996-99	18-4404	18-3894
C40 2 Cil	1994-97	18-4414	18-3892	D150	1997-99		18-3894
C40 3 Cil	1998-03	18-99061	18-99060	DX150	1999-03		18-3894
CV40	1990		18-3892	DX150	2004-05		18-3894
F40	2000-08	18-99092		L150	1986-89	18-4404	18-3894
P40	1998	18-99061	18-99060	L150	1990-95	18-4412	18-3894
50	1984-88	18-4407	18-3830	L150	1996-99		18-3894
50	1989-91	18-4419	18-3830	LX150	1999-01		18-3894
50	1992-94	18-4419	18-3830	LZ150	2000-03		18-99062
50	1995-09	18-99061	18-99060	LZ150	2004-05	18-99103	18-99062
C50	1998-01	18-99061	18-99060	Z150	2000-03		18-99062
PRO 50	1987-88	18-4407	18-3830	Z150	2004-05	18-99103	18-99062
PRO 50	1989-90	18-4419	18-3830	P150	1991-93	18-4412	18-3894
P50	1991	18-4419	18-3830	P150	1994-95		18-3894
P50	1992-94	18-4409	18-3830	P150	1996-99		18-3894
P50	1995-96	18-99061	18-99060	PX150	1999		18-3894
C55	1991		18-3848	PRO V150	1987-89	18-4404	18-3894
C55	1992-93		18-3848	PRO V150	1990	18-4412	18-3894
C55	1994-95		18-3848	S150	1996-99		18-3894
CV55	1989-90		18-3848	SX150	1999-03		18-3894
60	2001-05	18-99176	18-3831	SX150	2004		18-3894
C60	1996-01		18-3831	V150	2000-03		18-3894
E60	1995-00		18-3831	V150	2004-08		18-3894
P60	1991	18-4427	18-3831	VX150	2000-03		18-3894
P60	1992-93		18-3831	VX150	2004		18-3894
P60	1994-99	18-99176	18-3831	VZ150	2000-03		18-99062
70	1984-91	18-4427	18-3831	VZ150	2004-11	18-99103	18-99062
70	1992-93		18-3831	175	1984-89	18-4404	18-3894
70	1994-09	18-99176	18-3831	175	1990-95	18-4412	18-3894
C70	2000-01	18-99176	18-3831	175	2000		18-3894
C75	1994-96		18-3805	P175	1996-99		18-3894
C75	1998-99		18-3805	S175	1996-99		18-3894
E75	1995-00		18-3805	V175	2000		18-3894
F75	2003-04		18-99094	VZ175	2001-02		18-99062
F75	2005, 2007-11		18-99094	VZ175	2003-11	18-99103	18-99062
F75	2006		18-99094	Z175	2001-03		18-99062
P75	1996-99		18-3805	Z175	2004-05	18-99103	18-99062
C80	1997		18-3805	200	1984-89	18-4404	18-3894

① LJ:-357803/XJ:-700843

② LJ: 357804/XJ: 700844

③ 2.6 litros

④ 3.1 litros











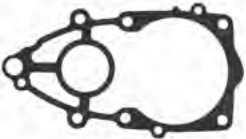



HP	Año	Juego de juntas bloque motor	Junta Culata	HP	Año	Juego de juntas bloque motor	Junta Culata
200	1990-95	18-4412	18-3894	L225 ④	1994-96	18-4400	18-3891
200	1996-98		18-3894	L225	1997-99		18-3891
L200	1986-89	18-4404	18-3894	S225	1996	18-4400	18-3891
L200	1990-95	18-4412	18-3894	S225	1997-99		18-3891
L200	1996-99		18-3894	LX225	2000-03		18-3891
LX200	1999-01		18-3894	SX225	2000-03		18-3891
LZ200	2000-03		18-99062	V225	1998-99		18-3891
LZ200	2004-11	18-99103	18-99062	VX225	2000-04		18-3891
P200	1991-95		18-3894	VZ225	2003-04		18-99048
P200	1996-99		18-3894	VZ225	2005-09		18-99048
S200	1996-99		18-3894	250	1990-95	18-4400	18-3891
SX200	1999-03		18-3894	L250	1990-96	18-4400	18-3891
SX200	2004-05		18-3894	L250	1997-99		18-3891
V200	1998-99		18-3891	LX250	2000-03		18-3891
VX200	2000-05		18-3891	LZ250	2003-04		18-99048
VZ200	2000-03		18-99062	LZ250	2005		18-99048
VZ200	2004-09	18-99103	18-99062	S250	1996	18-4400	18-3891
Z200	2000-03		18-99062	S250	1997-99		18-3891
Z200	2004-11	18-99103	18-99062	SX250	2000-03		18-3891
V6 Special	1984-86	18-4404	18-3894	VZ250	2003-04		18-99048
V6 Excel	1987-89		18-3894	VZ250	2005-09		18-99048
225 ③	1990-95		18-3894	Z250	2003-04		18-99048
225	1996-97		18-3894	Z250	2005		18-99048
225 ④	1994-95	18-4400	18-3891				

① LJ:-357803/XJ:-700843

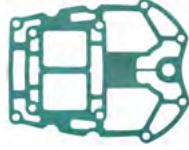
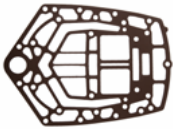
② LJ: 357804/XJ: 700844

③ 2.6 litros

④ 3.1 litros

 <p>18-0406 JUNTA BOMBA DE AGUA Reemplaza: 60X-43315-A0-00 Para: VZ200 (3.3L) 2005-10, VZ225 (3.3L) 2003-10, VZ250 (3.3L) 2003-10, VZ300 (3.3L) 2005-10</p>	 <p>18-0605 RETÉN COLECTOR ESCAPE Reemplaza: 67F-41138-00-00 Para: F75 2003-Actual: F80 1999-2003; F90 2003-Actual: F100 1999-2003; F115 2000-Actual.</p>	 <p>18-0617 RETÉN ESCAPE Reemplaza: 67F-45127-00-00 Para: F75 2003-Actual: F80 1999-2003; F90 2003-Actual: F100 1999-2003; F115 2000-Actual.</p>	 <p>18-0618 JUNTA DE COLECTOR ESCAPE Reemplaza: 68V-45123-00-00</p>
 <p>18-0619 RETÉN TUBO ESCAPE Reemplaza: 69J-41138-00-00</p>	 <p>18-0656 RETÉN TUBO ESCAPE Reemplaza: 69J-45123-00-00</p>	 <p>18-0755 JUNTA VACIADO DE CÁRTER Reemplaza: 90430-14M09-00, 904-30142-28-00, 90430-14228-00 Para: 4-tiempos 9.9hp.- 300hp. / 1999 - Actual</p>	 <p>18-0849 JUNTA MONTAJE BOMBA COMBUSTIBLE Reemplaza: 650-24431-A0-00</p>
 <p>18-0856 JUNTA Reemplaza: 64D-14384-01-00</p>	 <p>18-99000 JUNTA COLECTOR ESCAPE Reemplaza: 61A-41134-A0 Para: 225 (1994-95), 250 (1992-95), L225 (1994-99), L250 (1992-99), LX225 (2000-03), LX250 (2000-03), LZ250 (2003-05), LZ300 (2004-05), S225 (1996-99), S250 (1996-99), SX225 (2000-03), SX250 (2000-03), V200 (1998-99), V225 (1998-99), VX200 (2000-05), VX250 (2000-04), VZ200 (2005), VZ225 (2003-05), VZ250 (2003-05), VZ300(2004-05), Z250 (2003-05), Z300 (2004-05)</p>	 <p>18-99001 JUNTA DE CARTER SUPERIOR Reemplaza: 61A-45114-A0 Para: 225 (1994-95), 250 (1992-95), L225 (1994-99), L250 (1992-99), LX225 (2000-03), LX250 (2000-03), S225 (1996-99), S250 (1996-99), SX225 (2000-03), SX250 (2000-03), V200(1998-99), V225 (1998-99), VX200 (2000-05), VX225 (2000-04), VX250 (2002-04)</p>	 <p>18-99002 JUNTA COLECTOR ESCAPE Reemplaza: 62Y-41133-00 Para: F25(1998-00), F40(1999), F50(1995-00), T50(1996-00)</p>
 <p>18-99003 JUNTA ESCAPE Reemplaza: 62Y-41134-01 Para: F30(2002-05), F40(2002-08), F50(2002-04), F60(2002-04), T25(2002-05), T50(2002-04)</p>	 <p>18-99004 JUNTA CÁRTER SUPERIOR Reemplaza: 63D-45114-A0 Para: 40(1995-05), 50(1995-09), C40(1997-03), C50(1998-01), P40(1998), P50(1995-96)</p>	 <p>18-99005 JUNTA SILENCIADOR Reemplaza: 63D-45123-00 Para: 40(1995-05), 50(1995-09), C40(1997-03), C50(1998-01), P40(1998), P50(1995-96)</p>	 <p>18-99006 JUNTA COLECTOR ESCAPE Reemplaza: 63V-41133-A1 Para: 9.9(1997-09), 15(1997-09)</p>



18-99008
JUNTA COLECTOR ESCAPE
Reemplaza: 64J-41133-10
Para: F40(2008-10), F60(2002-04), T25(2009-10), T60(2003-04)



18-99009
JUNTA SILENCIADOR
Reemplaza: 663-45123-00
Para: (1985-94), (1984-94), C55(1991-95), CV55(1989-90), E48(1995-00), F40(1999), F50(1995-04), P50(1991-94), PR50(1989), PRO 50(1987-90), T50(1996-04)

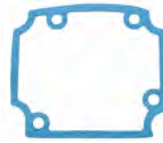

18-99010
JUNTA COLECTOR ESCAPE
Reemplaza: 664-41134-A0
Para: C25(1992-97), C30(1992-97)



18-99012
JUNTA COLECTOR ESCAPE
Reemplaza: 66M-41133-00
Para: F15(1998-04)

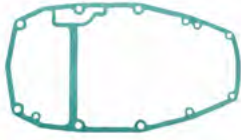

18-99013
JUNTA CÁRTER SUPERIOR
Reemplaza: 66M-45113-00
Para: F9.9 (2005-06), F15(1998-05), T9.9(2005-06)



18-99014
JUNTA COLECTOR ESCAPE
Reemplaza: 676-41133-A0
Para: C40(1992-97)

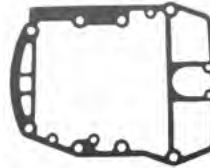

18-99015
JUNTA CÁRTER SUPERIOR
Reemplaza: 676-45114-A0
Para: C40(1991-97), CV40(1990)



18-99016
JUNTA COLECTOR ESCAPE
Reemplaza: 67C-41133-00
Para: F25(2001-05, 2009-10), F30(2001-05), F40(2000-08), F50(2001-04), T25(2005-06)



18-99017
JUNTA SILENCIADOR
Reemplaza: 67C-45123-00
Para: F30(2001-05), F40(2000-10), F60(2002-04), T25(2001-06, 2009-10), T60(2003-04)



18-99018
JUNTA COLECTOR ESCAPE
Reemplaza: 67F-41133-A1
Para: F75(2003-10), F90(2004-10), F115(2004-10), LF115(2004-10)



18-99019
JUNTA COLECTOR ESCAPE
Reemplaza: 67F-41134-A0
Para: F75(2003-10), F80(1999-03), F90(2003-10), F100(1999-03), F115(2000-10), LF115(2000-10)



18-99020
JUNTA SILENCIADOR
Reemplaza: 67F-45123-00
Para: F75(2003-10), F80(1999-03), F90(2003-10), F100(1999-03)



18-99021
JUNTA COLECTOR ESCAPE
Reemplaza: 682-41133-A0
Para: 9.9(1992-95), 15(1992-95)



18-99022
JUNTA CÁRTER SUPERIOR
Reemplaza: 682-45113-A1
Para: 9.9(1984-95), 15(1984-95)



18-99023
JUNTA COLECTOR ESCAPE
Reemplaza: 688-41133-00
Para: 90(1984-09), B90(1997-99), C75(1994-96, 98-99), C80(1997), C85(1991-96), C90(1997-01), CV85(1989-90), E75(1995-00), P75(1996-99)

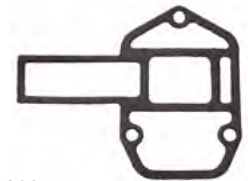

18-99024
JUNTA COLECTOR ESCAPE
Reemplaza: 688-41134-A0
Para: 90(1984-09), B90(1997-99), C75(1994-99), C80(1997), C85(1991-96), C90(1997-01), CV85(1989-90), E75(1995-00), P75(1996-99)

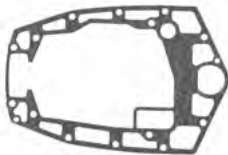

18-99025
JUNTA CÁRTER SUPERIOR
Reemplaza: 688-45114-A1
Para: 90(1984-09), B90(1997-99), C75(1994-99), C80(1997), C85(1991-96), C90(1997-01), CV85(1989-90), E75(1995-00), P75(1996-99)



18-99026
JUNTA SILENCIADOR
Reemplaza: 688-45123-00
Para: 90(1984-09), B90(1997-99), C75(1994-99), C80(1997), C85(1991-96), C90(1997-01), CV85(1989-90), E75(1995-00), P75(1996-99)

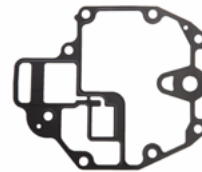

18-99027
JUNTA CÁRTER
Reemplaza: 68T-13475-00
Para: F6(2001-08), F8(2001-10), F9.9(2007, 2010), T8(2001-10), T9.9(2007-10)

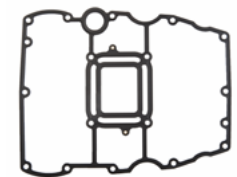

18-99028
JUNTA CÁRTER
Reemplaza: 68V-15312-00
Para: F75(2003-10), F90(2004-10), F115(2004-10), LF115(2004-10)



18-99030
JUNTA CÁRTER SUPERIOR
Reemplaza: 697-45114-A0
Para: E48(1995-00), C55(1992-95)

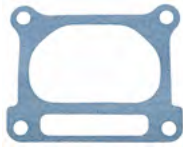

18-99032
JUNTA COLECTOR ESCAPE
Reemplaza: 69J-41134-A0
Para: F200(2002-05), F225(2002-05), LF200(2002-05), LF225(2002-05)

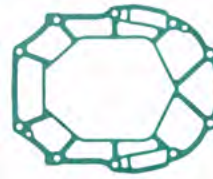

18-99033
JUNTA COLECTOR ESCAPE
Reemplaza: 69J-41135-A0
Para: F200(2002-10), F225(2002-10), F250(2005-10), LF200(2002-10), LF225(2002-10), LF250(2005-10)



18-99034
JUNTA COLECTOR ESCAPE
Reemplaza: 69J-41136-A0
Para: F200(2002-05), F225(2002-05), F250(2005), LF200(2002-05), LF225(2002-05), LF250(2005)



18-99037
JUNTA COLECTOR ESCAPE
Reemplaza: 6E5-41134-A0
Para: 115(1992-09), 130(1992-04), B115(1998-99), C115(1992-00), L130(1994-01), P115(1993-96), S115(1996-99), S130(1996-99)

18-99038
JUNTA COLECTOR ESCAPE

Reemplaza: 6E5-41135-A0
Para: 115(1992-09), 130(1992-04), 150(1992-09), 175(1992-95), 2000, 200(1992-98), 225(1992-97), B115(1998-99), C115(1992-00), C150(1996-99), D150(1997-99), DX150(1999-05), L150(1992-01), L200(1992-99), LX150(1999-01), LX200(1999-01), LZ150(2000-05), LZ200(2000-10), P115(1993-96), P150(1992-99), P175(1994-99), P200(1992-99), PX150(1999), S115(1996-99), S130(1996-99), S150(1996-99), S175(1996-99), S200(1996-99), SX150(1999-04), SX200(1999-05), V150(2000-08), V175(2000), VX150(2000-04), VZ150(2000-10), VZ175(2001-10), VZ200(2001-04), Z150(2000-05), Z175(2001-05), Z200(2000-10)



18-99039
JUNTA COLECTOR ESCAPE
Reemplaza: 6G5-41134-A1
Para: 115(2003-04), 130(2003-04), 150(2003-09), DX150(2003-05), LZ150(2003-05), LZ200(2003-10), SX150(2003-04), SX200(2003-05), V150(2003-08), VX150(2003-10), VZ150(2003-10), VZ175(2003-10), VZ200(2003-04), Z150(2003-05), Z175(2003-05), Z200(2003-10)



18-99040
JUNTA CÁRTER SUPERIOR
Reemplaza: 6G5-45114-A1
Para: 115(2003-09), 130(2003-04), 150(2003-09), DX150(2003-05), LZ150(2003-05), LZ200(2003-10), SX150(2003-04), SX200(2003-05), V150(2003-08), VX150(2003-04), VZ150(2003-10), VZ175(2003-10), VZ200(2003-04), Z150(2003-05), Z175(2003-05), Z200(2003-10)



18-99045
JUNTA CÁRTER SUPERIOR
Reemplaza: 6G8-45113-A1
Para: F9.9(1997-05), T9.9(1995-05)



18-99046
JUNTA CÁRTER SUPERIOR
Reemplaza: 6H3-45114-A1
Para: 60(2002-05), 70(1984-069), C60(1996-01), C70(2001-02), E60(1995-00), P60(1991-99)



18-99047
JUNTA SILENCIADOR
Reemplaza: 6H3-45123-00
Para: 60(2001-05), 70(1984-09), C60(1996-01), C70(2000-01), E60(1995-00), P60(1991-99)



18-99049
JUNTA
Reemplaza: 60V-13621-A0
Para: LZ250(2003-05), LZ300(2004-06), VZ200(2005-09), VZ225(2003-09), VZ250(2003-09), VZ300(2004-09), Z250(2003-05), Z300(2004-06)



18-99050
JUNTA DE ADMISIÓN
Reemplaza: 60V-13645-00
Para: LZ250(2003-05), LZ300(2004-06), VZ200(2005-09), VZ225(2003-09), VZ300(2004-09), Z250(2003-05), Z300(2004-06)



18-99051
JUNTA TAPA VÁLVULA
Reemplaza: 61A-11193-A1
Para: L225(1996-99), L250(1996-99), LX225(2000-03), LX250(2000-03), S225(1996-99), S250(1996-99), SX225(2000-03), SX250(2000-03), V200(1998-99), V225(1998-99), VX200(2000-05), VX225(2000-04)



18-99052
JUNTA TAPA
Reemplaza: 61A-11381-A0
Para: 225(1994-95), 250(1992-95), L225(1994-99), L250(1992-99), LX225(2000-03), LX250(2000-03), S225(1996-99), S250(1996-99), SX225(2000-03), SX250(2000-03), V200(1998-99), V225(1998-99), VX200(2000-05), VX225(2000-04), VX250(2002-04)



18-99053
JUNTA DE ADMISIÓN
Reemplaza: 61A-13621-A0
Para: 225(1994-95), 250(1992-95), DX150(1999-05), L225(1994-99), L250(1992-99), LX150(1999-01), LX200(1999-01), LX225(2000-03), LX250(2000-03), LZ150(2000-05), LZ200(2000-10), PX150(1999), S225(1996-99), S250(1996-99), SX150(1999-04), SX200(1999-05), SX225(2000-03), SX250(2000-03), V200(1998-99), V225(1998-99), VX150(2000-04), VX200(2000-05), VX225(2000-04), VX250(2002-04), VZ150(2000-10), VZ175(2001-10), VZ200(2001-04), Z150(2000-05), Z175(2001-05), Z200(2000-10)



18-99054
JUNTA DE ADMISIÓN
Reemplaza: 61A-13645-00
Para: 225(1994-95), 250(1990-95), L225(1994-96), L250(1990-96), S225(1996), S250(1996)

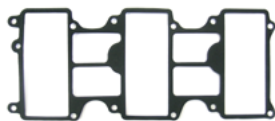

18-99055
JUNTA COLECTOR
Reemplaza: 61A-13646-00
Para: 225(1994-95), 250(1990-95), L225(1994-96), L250(1990-96), S225(1996), S250(1996)





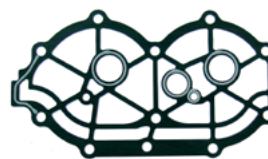









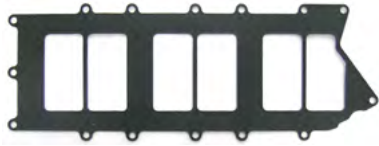





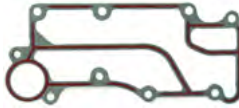



18-99056
JUNTA BASE
Reemplaza: 61A-45113-A0
Para: 225(1994-95), 250(1990-95), L225(1994-99), L250(1990-99), LX225(2000-03), LX250(2000-03), S225(1996-99), S250(1996-99), SX225(2000-03), SX250(2000-03), V200(1998-99), V225(1998-99), VX200(2000-05), VX225(2000-04), VX250(2002-04)













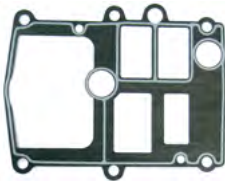





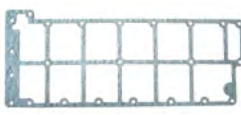
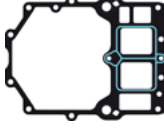

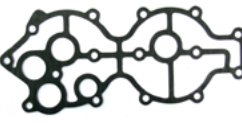
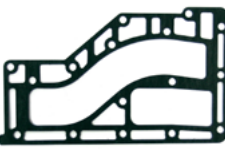
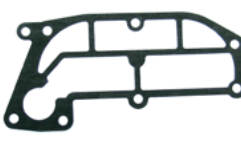

18-99057
JUNTA TAPA VÁLVULA
Reemplaza: 61T-11193-A1
Para: C30(1993-97)

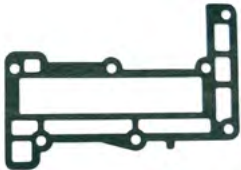

18-99063
JUNTA CÁRTER INFERIOR
Reemplaza: 63V-45315-A0
Para: 9.9(1996-09), 15(1996-09), F9.9(2005-06), F15(1998-05), T9.9(2005-06)

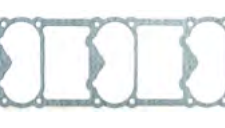
 <p>18-0242 JUNTA VALVULA Reemplaza: 663-13622-00-00,663-13622-A0-00</p>	 <p>18-99066 JUNTA ADMISIÓN Reemplaza: 65L-13645-00 Para: DX150(1999-05), L225(1997-99), L250(1997-99), LX150(1999-01), LX200(1999-01), LX225(2000-03), LX250(2000-03), LZ150(2000-05), LZ200(2000-10), PX150(1999), S225(1997-99), S250(1997-99), SX150(1999-04), SX200(1999-05), SX200(2000-03), SX225(2000-03), SX250(2000-03), V200(1998-99), V225(1998-99), VX150(2000-04), VX200(2000-05), VX225(2000-04), VX250(2002-04), VZ150(2000-10), VZ175(2001-10), VZ200(2001-04), Z150(2000-05), Z175(2001-05), Z200(2000-10)</p>		 <p>18-99067 JUNTA ADMISIÓN Reemplaza: 65L-13646-00 Para: DX150(1999-05), L225(1997-99), L250(1997-99), LX150(1999-01), LX200(1999-01), LX225(2000-03), LX250(2000-03), LZ150(2000-05), LZ200(2000-10), PX150(1999), S225(1997-99), S250(1997-99), SX150(1999-04), SX200(1999-05), SX200(2000-03), SX225(2000-03), SX250(2000-03), V200(1998-99), V225(1998-99), VX150(2000-04), VX200(2000-05), VX225(2000-04), VX250(2002-04), VZ150(2000-10), VZ175(2001-10), VZ200(2001-04), Z150(2000-05), Z175(2001-05), Z200(2000-10)</p>	
 <p>18-99064 JUNTA ADMISIÓN Reemplaza: 64E-13645-A0 Para: 150(1996-99), 200(1996-98), 225(1996-97), D150(1997-99), L150(1996-99), L200(1996-99), P150(1996-99), P175(1996-99), P200(1996-99), S150(1996-99), S175(1996-99), V150(2000-08), V175(2000)</p>	 <p>18-99068 JUNTA TAPA RESPIRADERO Reemplaza: 65W-11169-00 Para: F25(1998-01), T25(2001)</p>	 <p>18-99069 JUNTA BASE Reemplaza: 65W-11351-00 Para: F25(1998-02), T25(2001-02)</p>	 <p>18-99070 JUNTA CARTER Reemplaza: 65W-11356-00 Para: F25(1998-05), T25(2001-06)</p>	 <p>18-99071 JUNTA Reemplaza: 65W-14457-10 Para: F25(1999-05), T25(2001-06)</p>
 <p>18-99072 JUNTA ESCAPE Reemplaza: 65W-41114-00 Para: F25(1998-05), T25(2001-06)</p>	 <p>18-99074 JUNTA BASE Reemplaza: 66M-11351-10 Para: F9.9(2005-06), F15(2005), T9.9(2005-06)</p>	 <p>18-99075 JUNTA TAPA Reemplaza: 66M-11356-00 Para: F9.9(2005-06), F15(1998-05), T9.9(2005-06)</p>	 <p>18-99076 JUNTA BOMBA AGUA Reemplaza: 66M-13329-10 Para: F9.9(2005-06), F15(2001-05), T9.9(2005-06)</p>	
 <p>18-99078 JUNTA Reemplaza: 66M-41138-00 Para: F15(1998-04)</p>	 <p>18-99079 JUNTA CÁRTER SUPERIOR Reemplaza: 66M-45115-00 Para: F9.9(2005-06), F15(1998-05), T9.9(2005-06)</p>	 <p>18-99080 JUNTA ADMISIÓN Reemplaza: 676-13646-A0 Para: C40(1991-97), CV40(1990)</p>	 <p>18-99082 JUNTA BOMBA AGUA Reemplaza: 676-44315-A1 Para: C40(1991-97), CV40(1990)</p>	 <p>18-99083 JUNTA BOMBA AGUA Reemplaza: 676-44324-A0 Para: C40(1991-97), CV40(1990)</p>
 <p>18-99084 JUNTA ESCAPE Reemplaza: 676-45127-00 Para: C40(1991-97), CV40(1990)</p>	 <p>18-99085 JUNTA ESCAPE Reemplaza: 676-45128-00 Para: C40(1991-97), CV40(1990)</p>	 <p>18-99086 JUNTA BOMBA AGUA Reemplaza: 679-44316-A0 Para: C40(1991-97), CV40(1990)</p>	 <p>18-99087 JUNTA CARTER INFERIOR Reemplaza: 679-45315-A0 Para: C40(1991-94), CV40(1990)</p>	 <p>18-99088 JUNTA TAPA Reemplaza: 67C-11356-00 Para: F30(2001-05), F40(2000-08)</p>

 <p>18-99089 JUNTA ESCAPE Reemplaza: 67C-41114-00 Para: F30(2001), F40(2000-01)</p>	 <p>18-99091 JUNTA Reemplaza: 67C-45113-00 Para: F25(2001), F30(2001), F40(2000-01), t25(2001)</p>	 <p>18-99095 JUNTA BASE Reemplaza: 682-11351-A0 Para: 9.9(1984-95), 15(1984-95)</p>	 <p>18-99096 JUNTA Reemplaza: 682-41112-A1 Para: 9.9(1984-95), 15(1984-95)</p>	 <p>18-60508 JUNTA TERMOSTATO Reemplaza: 60V-12414-A0-00 Para: Yamaha LZ250(2003-05), LZ300(2004-06), VZ200(2005-09), VZ225(2003-09), VZ250(2003-09), VZ300(2004-09), Z250(2003-05), Z300(2004-06)</p>
 <p>18-99098 JUNTA ADMISIÓN Reemplaza: 688-13621-A1 Para: 90(1992-09), B90(1997-99), C75(1994-99), C80(1997), C85(1992-96), C90(1997-01), E75(1995-00), P75(1996-99)</p>	 <p>18-99099 JUNTA TAPA VÁLVULA Reemplaza: 68F-11193-01 Para: LZ150(2000-05), LZ200(2000-08), VZ150(2000-08), VZ175(2001-08), VZ200(2001-04), Z150(2000-05), Z175(2001-05), Z200(2000-08)</p>	 <p>18-99100 JUNTA Reemplaza: 68F-11381-00 Para: LZ150(2000-05), LZ200(2000-10), VZ150(2000-10), VZ175(2001-10), VZ200(2001-04), Z150(2000-05), Z175(2001-05), Z200(2000-10)</p>	 <p>18-99101 JUNTA ESCAPE Reemplaza: 68F-41114-00 Para: LZ150(2000-05), LZ200(2000-10), VZ150(2000-10), VZ175(2001-10), VZ200(2001-04), Z150(2000-05), Z175(2001-05), Z200(2000-10)</p>	 <p>18-99102 JUNTA BASE Reemplaza: 68F-45113-00 Para: 150(2004-08), DX150(2004-05), LZ150(2000-05), LZ200(2000-08), SX150(2004), SX200(2004-05), V150(2004-08), VX150(2004), VZ150(2000-08), VZ175(2001-08), VZ200(2001-04), Z150(2000-05), Z175(2001-05), Z200(2000-08)</p>
 <p>18-99105 JUNTA ADMISIÓN Reemplaza: 6E5-13621-A1 Para: 115(1992-09), 130(1992-04), 150(1992-09), 175(1992-95, 2000), 200(1992-98), B115(1998-969), C115(1992-00), C150(1996-99), L130(1992-01), L150(1992-99), L200(1992-98), P115(1993-96), P150(1993), S115(1996-99), S130(1996-99), S150(1996-99), S175(1996-99), S200(1996-99)</p>	 <p>18-99106 JUNTA TAPA VÁLVULA Reemplaza: 6E9-11193-A0 Para: C40(1991-97), CV40(1990)</p>	 <p>18-99107 JUNTA ESCAPE Reemplaza: 6E9-41114-A0 Para: C40(1992-97)</p>	 <p>18-99108 JUNTA TAPA VÁLVULA Reemplaza: 6G1-11193-A1 Para: 6(1986-00), 8(1984-09)</p>	 <p>18-99109 JUNTA Reemplaza: 6G1-13621-A1 Para: 6(1991-00), 8(1991-09)</p>
 <p>18-99110 JUNTA ADMISIÓN Reemplaza: 6G1-13645-A1 Para: 6(1991-00), 8(1991-09)</p>	 <p>18-99111 JUNTA ADMISIÓN Reemplaza: 6G1-14198-A1 Para: 6(1986-00), 8(1984-09)</p>	 <p>18-99112 JUNTA ESCAPE Reemplaza: 6G1-41112-A1 Para: 6(1986-00), 8(1984-09)</p>	 <p>18-99113 JUNTA ESCAPE Reemplaza: 6G1-41114-A0 Para: 6(1991-00), 8(1991-09)</p>	 <p>18-99114 JUNTA ESCAPE Reemplaza: 6G1-41133-A0 Para: 6(1992-00), 8(1992-09)</p>
 <p>18-99115 JUNTA BASE Reemplaza: 6G1-45113-A1 Para: 6(1986-00), 8(1984-09)</p>	 <p>18-99116 JUNTA BOMBA AGUA Reemplaza: 6G1-45315-A0 Para: 6(1986-00), 8(1984-09)</p>	 <p>18-99118 JUNTA CARBURADOR Reemplaza: 6G5-14483-A1 Para: C150(1996-99)</p>	 <p>18-99119 JUNTA BASE Reemplaza: 6G8-11351-A0 Para: F9.9(1985-05), FT9.9(1985-90), T9.9(1991-05)</p>	 <p>18-99120 JUNTA TERMOSTATO Reemplaza: 6G8-12414-A0 Para: F6(2001-04), F8(2001-04), F9.9(1985-05, 2007, 2010), FT9.9(1985-90), T8(2001-04), T9.9(1991-05, 2007-10)</p>



18-99121
JUNTA ADMISIÓN
Reemplaza: 6G8-13646-A0
Para: F9.9(1985-05), FT9.9(1985-90), T9.9(1991-05)



18-99122
JUNTA ADMISIÓN
Reemplaza: 6G8-14198-A0
Para: F9.9(1992-05), T9.9(1992-05)



18-99123
JUNTA
Reemplaza: 6G8-15374-00
Para: F9.9(1985-05), FT9.9(1985-90), T9.9(1991-05)



18-99124
JUNTA TERMOSTATO
Reemplaza: 6H3-12414-A1
Para: 60(2001-05), 70(1984-09), C60(1996-01), C70(2000-01), E60(1995-00), P60(1991-99)



18-99125
JUNTA ADMISIÓN
Reemplaza: 6H3-13622-00
Para: 70(1985-91), P60(1991)



18-99126
JUNTA ADMISIÓN
Reemplaza: 6H3-14198-01
Para: 70(1984-91), P60(1991)



18-99128
JUNTA ESCAPE
Reemplaza: 6H3-41114-A0
Para: 60(2001-05), 70(1992-09), C60(1996-01), C70(2000-01), E60(1995-00), P60(1992-99)

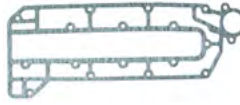

18-99129
JUNTA ESCAPE
Reemplaza: 6H3-41112-A0
Para: 60(2001-05), 70(1986-09), C60(1996-01), C70(2000-01), E60(1995-00), P60(1991-99)



18-99130
JUNTA ESCAPE
Reemplaza: 6H3-45113-A0
Para: 60(2001-025), 70(1984-09), C60(1996-01), C70(2000-01), E60(1995-00), P60(1991-99)



18-99132
JUNTA
Reemplaza: 6H4-13621-A1
Para: 40(1984-05), 50(1984-09), C40(1997-03), C50(1998-01), P40(1998), P50(1991-96), PR50(1989), Pro 50(1987-90)



18-99133
JUNTA
Reemplaza: 6H4-14198-01
Para: 40(1989-05), 50(1989-09), C40(1997-03), C50(1998-01), P40(1998), P50(1991-96), PR50(1989), Pro 50(1989-90)



18-99134
JUNTA
Reemplaza: 6H4-15369-A1
Para: 40(1984-01), 50(1984-09), C40(1997-03), C50(1998-01), P40(1998), P50(1991-96), PR50(1989), Pro 50(1987-90)



18-99135
JUNTA ESCAPE
Reemplaza: 6H4-41112-A0
Para: 40(1992-05), 50(1992-09), C40(1997-03), C50(1998-01), P40(1998), P50(1992-96)



18-99136
JUNTA ADMISIÓN
Reemplaza: 6K7-13646-A1
Para: 225(1990-95), P150(1994-95), P175(1994-95), P200(1992-95), V6 Excel(1987-89)



18-99137
JUNTA ESCAPE
Reemplaza: 6L2-41133-A2
Para: 25(2004-08)



18-99138
JUNTA BOMBA AGUA
Reemplaza: 6L2-45315-A0
Para: 20(1996-97), 25(1992-09)

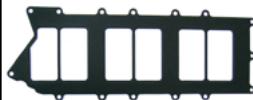

18-99139
JUNTA ADMISIÓN
Reemplaza: 6OV-13646-00
Para: LZ250(2003-05), LZ300(2004-06), VZ200(2005-09), VZ225(2003-09), VZ250(2003-09), VZ300(2004-09), Z250(2003-05), Z300(2004-06)



18-99140
JUNTA CULATA
Reemplaza: 63V-11181-A1, 63V-11181-A2
Para: 9.9(1997-08), 15(1997-08)



18-99141
JUNTA TAPA
Reemplaza: 6H3-11193-A1
Para: 60(2001-05), 70(1984-09), C60(1996-01), C70(2000-01), E60(1995-00), P60(1991-99)



18-99142
JUNTA TERMOSTATO
Reemplaza: 6E9-12414-A0, 6E9-12414-A1
Para: C40(1992-97)



18-99143
JUNTA VÁLVULA
Reemplaza: 6H3-13621-A1
Para: 60(2001-05), 70(1992-09), C60(1996-01), C70(2000-01), E60(1995-00), P60(1992-99)



18-99144
JUNTA TAPA MEZCLADO
Reemplaza: 6E7-14227-00
Para: 9.9(1984-95), 15(1984-95)



18-99145
JUNTA CARBURADOR
Reemplaza: 677-14198-00, 677-14198-A1
Para: 9.9(1984-91), 15(1984-91)



18-99147
JUNTA BOMB. COMB.
Reemplaza: 6G1-24431-01
Para: 3(1990-02), 6(1990-00), 8(1990-09), 9.9(1996-09), 15(1996-09)

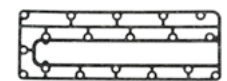

18-99148
JUNTA TAPA ESCAPE
Reemplaza: 688-41114-A0
Para: 90(1992-09), B90(1998-99), C75(1994-99), C80(1997), C85(1992-96), C90(1997-01), E75(1995-00), P75(1996-99)

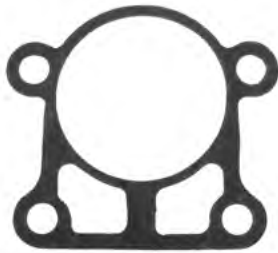

18-99149
JUNTA BOMBA AGUA
 Reemplaza: 663-44316-A0
 Para: 25(1997-02), 30(1992-01), 40(1992-94), 50(1992-94), C30(1995), C55(1992-95), E48(1995-00), P50(1992-94)

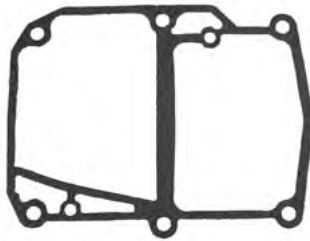

18-99150
JUNTA CÁRTER SUPERIOR
 Reemplaza: 63V-45113-A1
 Para: 9.9(1997-09), 15(1997-09)

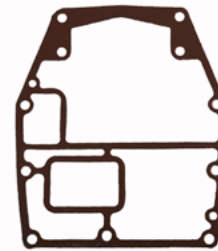

18-99151
JUNTA CÁRTER SUPERIOR
 Reemplaza: 688-45113-A0
 Para: 90(1984-09), B90(1997-99), C75(1994-99), C80(1997), C85(1991-96), C90(1997-01), C85(1989-90), E75(1995-00), P75(1996-99)



18-99152
JUNTA CÁRTER INFERIOR
 Reemplaza: 683-45315-A0
 Para: 9.9(1984-95), 15(1984-95), F9.9(1986-05)

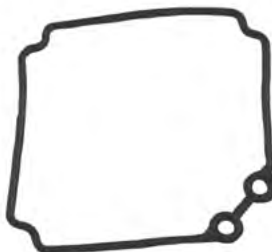

18-0765
JUNTA COMANDA FLOTACIÓN
 Reemplaza: 6L2-14384-00-00

Pack. de 2



18-0775
18-0775-9①
JUNTA MONTAJE
 Reemplaza: 648-14198-A0-00



18-0785
JUNTA MONTAJE CARBURADOR
 Reemplaza: 6E5-14198-A1-00

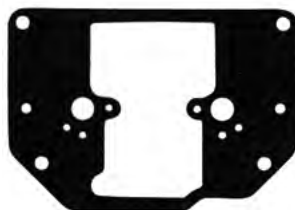

18-0786
JUNTA CAMARA FLOTACIÓN
 Reemplaza: 6E5-14384-02-00



18-2592
JUNTA FLOTADOR
 Reemplaza: 6E5-14384-03-00
 Para: V-4 Fuerbordas: 115, 130, 150, 175, 200, 225 (1986-96) V-6 Especial & Excel (1986-89)

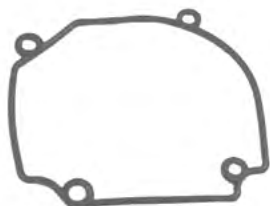

18-0840-1
JUNTA CAMARA FLOTACIÓN
 Reemplaza: 676-14984-00-00













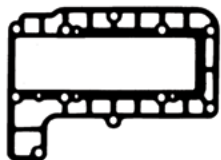
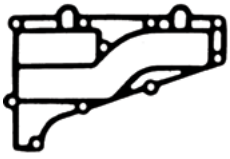

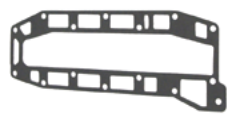

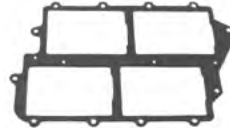
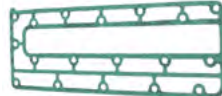





18-0807-1
JUNTA
 Reemplaza: 6K7-13645-A1-00







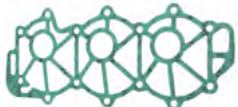
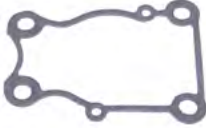



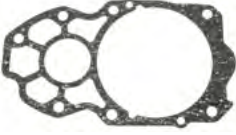









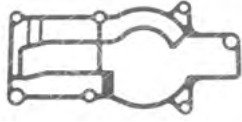
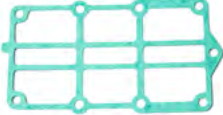



18-0809
JUNTA
 Reemplaza: 6G5-13645-A1-00

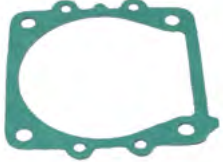

18-64415
O₂ KIT SENSOR
 Reemplaza: 68F-W1135-00-00
 Para: Yamaha DX150(2001-05), LX150(2001), LX200(2001), LX225(2001-02), LX250(2001-02), LZ150(2000-05), LZ200(2000-12), SX150(2001-04), SX200(2001-05), SX225(2001-02), SX250(2001-02), VX150(2001-04), VX200(2001-02), VX225(2001-02), VZ150(2000-14), VZ175(2001-12), VZ200(2001-04), Z150(2000-05), Z175(2001-05), Z200(2000-12)

 <p>18-0808 JUNTA VÁLVULA PRESIÓN Reemplaza: 6G5-11382-A1-00</p>	 <p>18-0250 JUNTA TAPA ESCAPE Reemplaza: 664-41114-A0-00</p>	 <p>18-0743 JUNTA TAPA ESCAPE ESCAPE Reemplaza: 6L2-41112-A1-00</p>	 <p>18-0744 JUNTA TAPA ESCAPE Reemplaza: 6L2-41114-A1-00</p>	 <p>18-0798 JUNTA TAPA ESCAPE Reemplaza: 6H4-41114-A0-00</p>
 <p>18-0799 JUNTA TAPA ESCAPE Reemplaza: 6E5-41112-A1-00</p>	 <p>18-0812 JUNTA TAPA ESCAPE Reemplaza: 6G5-41112-A1-00</p>	 <p>18-0823 JUNTA TAPA ESCAPE Reemplaza: 6E5-13645-A1-00</p>	 <p>18-0847 JUNTA TAPA ESCAPE Reemplaza: 688-41112-A0-00 Para: 90 HP</p>	 <p>18-0739 JUNTA SUPERIOR Reemplaza: 689-45113-A1-00</p>
 <p>18-0813 JUNTA BASE Reemplaza: 6G5-45113-A0-00</p>	 <p>18-0232 JUNTA TAPA Reemplaza: 655-12414-A1-00</p>	 <p>18-0782 JUNTA TAPA Reemplaza: 6E5-11381-A1-00</p>	 <p>18-0829 JUNTA TAPA Reemplaza: 61A-12414-A0-00, 6J8-12414-A0-00</p>	 <p>18-99127 JUNTA TERMOSTATO Reemplaza: 63P-12414-00-00. Para: F150/LF150(2014-11), F150A/LF150A(2012-14), F150B/LF150B(2015-18)</p>
 <p>18-0754 JUNTA TERMOSTATO Reemplaza: 68D-E2414-A0-00 Para: F2.5MSH-0405, F2.5MSH-0406, F2.5MSH-0407, F2.5MSH0608, F2.5MSHD-2007</p>	 <p>18-0835 JUNTA TERMOSTATO Reemplaza: 62Y-12414-00-00 Para: F 9.9, T9.9 (2005-06), 15 (2006), F15, F25 (1998-06), T25, F30 (2001-06), F40 4cil (1999), F40 3cil (2000-06), F50 (1996-06), T50 (1996-06), F60 (2002-06), T60 (2003-06)</p>	 <p>18-0836 JUNTA TERMOSTATO Reemplaza: 682-12414-A1-00 Para: 9.9, 15 (1984-06)</p>	 <p>18-0844 JUNTA TERMOSTATO Reemplaza: 688-12414-A1-00 Para: 90 HP V-4, V-6</p>	 <p>18-0767 JUNTA Reemplaza: 688-11193-01-00 Para: 90 HP</p>
 <p>18-0779 JUNTA Reemplaza: 6G5-11193-A0-00</p>	 <p>18-0781 JUNTA Reemplaza: 6E5-11193-A0-00</p>	 <p>18-0815 JUNTA Reemplaza: 6H4-11193-A1-00</p>	 <p>18-0483 JUNTA BOMBA Reemplaza: 63D-44316-00-00 Para: 40 (1995-04), 50 (1995-97, 1999-04)</p>	 <p>18-0753 JUNTA BOMBA AGUA Reemplaza: 6G1-44315-A0-00 Para: 6 (1986-00), 8 (1984-05)</p>

 <p>18-0239 JUNTA BOMBA AGUA Reemplaza: 688-44315-A0-00</p>	 <p>18-3458 JUNTA BOMBA AGUA Reemplaza: 6CE-44315-00-00 Para: F225(2010-15), F250(2010), F250(2010-15), F300(2007-15), F350(2007-15), FL250(2010), FL300(2010), FL350(2010), LF225(2010-15), LF250(2010-15), LF300(2007-15), LF350(2007-15), VF250(2015).</p>	 <p>18-60512 JUNTA Reemplaza: 68D-E1169-A0-00 Para: Yamaha F4(2002-08)</p>	 <p>18-60521 JUNTA TAPA CILINDRO Reemplaza: 69M-11196-A0-00 Para: Yamaha F2.5(2003-14), F4(1999-14), F6(2009-14)</p>	 <p>18-60529 JUNTA COLECTOR ESCAPE Reemplaza: 66T-41133-A0-00 Para: Yamaha T40/T30 Enduro Series</p>
 <p>18-63966 JUNTA CULATA CILINDRO Reemplaza: 66M-11181-10-00 Para: Yamaha F9.9(2005-06), F15(2005-06), T9.9(2005-06)</p>	 <p>18-60513 JUNTA Reemplaza: 66M-11357-00-00 Para: Yamaha F9.9(2005-06), F15(1998-06), T9.9(2005-06)</p>	 <p>18-60522 JUNTA TAPA CILINDRO Reemplaza: 66T-11181-A0-00 Para: Yamaha F2.5(2003-14), F4(1999-14), F6(2009-14)</p>	 <p>18-60518 JUNTA TAPA CILINDRO Reemplaza: 68D-11351-A0-00 Para: Yamaha F4(2002-08).</p>	 <p>18-60530 JUNTA TAPA ESCAPE Reemplaza: 66M-41114-01-00 Para: Yamaha F9.9(2005-06), F15(2005-06), T9.9(2005-06)</p>
 <p>18-60523 JUNTA TAPA CILINDRO Reemplaza: 69M-11181-00-00 Para: Yamaha F2.5(2003 & Sup)</p>	 <p>18-60519 JUNTA TAPA CILINDRO Reemplaza: 68D-E1193-A0-00 Para: Yamaha F4(2002-08)</p>	 <p>18-60527 JUNTA MOTOR Reemplaza: 67D-45113-A0-00 Para: Yamaha F4(1999-08)</p>	 <p>18-60532 JUNTA TAPA ESCAPE Reemplaza: 66T-41114-A0-00 Para: Yamaha T40/T30 Enduro Series</p>	 <p>18-60520 JUNTA TAPA CILINDRO Reemplaza: 66T-11193-A0-00 Para: Yamaha T40/T30 Enduro Series</p>
 <p>18-60528 JUNTA MOTOR Reemplaza: 66T-45113-A0-00 Para: Yamaha T40/T30 Enduro Series</p>	 <p>18-60534 JUNTA COLECTOR Reemplaza: 66M-13645-00-00 Para: Yamaha F9.9(2005-06), F15(1998-06), T9.9(2005-06)</p>	 <p>18-60535 JUNTA COLECTOR Reemplaza: 65W-13645-00-00 Para: F25(1998-05), T25(2001-06)</p>	 <p>18-60540 JUNTA TERMOSTATO Reemplaza: 676-12414-A0-00 Para: Yamaha T40/T30 Enduro Series</p>	 <p>18-60541 JUNTA TAPA BOMBA AGUA Reemplaza: 6BX-G4315-01-00 Para: F4(2009-14), F6(2009-14)</p>
 <p>18-0240 JUNTA BOMBA DE AGUA Reemplaza: 688-44316-A0-00</p>	 <p>18-0244 JUNTA BOMBA DE AGUA Reemplaza: 6E5-44315-A0-00</p>	 <p>18-0292 PLATINA A JUNTA BASE BOMBA Reemplaza: 663-44315-A0-00</p>	<p>Pack. de 2</p>  <p>18-0294 18-0294-9 ① PLATINA A JUNTA BASE BOMBA Reemplaza: 663-44324-A0-00</p>	 <p>18-0756-1 JUNTA BOMBA DE AGUA Reemplaza: 6H3-44315-A0-00</p>



18-0757
JUNTA PLATINA
Reemplaza: 6H3-44324-A0-00

Pack. de 2



18-0768
18-0768-9 ①
JUNTA PLATINA
Reemplaza: 682-44315-A0-00



18-0826
JUNTA TORNILLO DRENAJE
Reemplaza: 90430-14115-00
Para: 40-90 HP



18-4274
ESPACIADOR HÉLICE
Reemplaza: 688-45997-01-00



18-2448
KIT INFERIOR DE LLENADO Y VACIADO
M8 - 1.25 Dientes
Para: Yamaha, Nissan/Tohatsu, & Honda parte inferior



18-4698
18-46981-9 ①
(Pack. de 50)
ARAND. DRENAJE/ LLENADO
Reemplaza: 90430-08020-00



18-2371
18-23711-9 ①
(Pack. de 50)
TORNILLO DRENAJE
M8 - 1.25 Dientes
Reemplaza: 90340-08002-00, 90340-08M04-00
Use Junta 18-4698



18-2374
18-23741-9 ①
(Pack. de 50)
TORNILLO DRENAJE MAGNÉTICO
M8 - 1.25 Dientes
Reemplaza: 688-45341-00-00, 688-45341-10-00
Use junta 18-4698



18-2388
EJE HÉLICE
Reemplaza: 688-45611-00-00
Para: F40 (1999) F50(1999-00) C60/C70/ C90 (2000-01) C75 (1994) C85 (1991-94)



18-2385
EJE HÉLICE
Reemplaza: 6E5-45611-01-00
Para: 115/130HP

MUELLE



18-51001
Reemplaza: 63V-15713-00-00
Para: 9.9(1996-09), 15(1996-09), F6(2001-08), F8(2001-14), F9.9(2005-14), F15(1998-14), F20(2006-14), T8(2002-10), T9.9(2007-14)



18-51002
Reemplaza: 67D-15713-00-00
Para: F2.5(2003-14), F4(1999-14), F6(2009-14)



18-51003
Reemplaza: 66T-15713-00-00
Para: F25(2009-14), F30(2001-05), F40(2001-08)

Modelo	Año	Ref #	Modelo	Año	Ref #
40EJRP - 50TLHS	1984-1997	N/D	F115TLR	2006 & SUP	18-2385
50ETSN - 50TLHS	1984-1994	N/D	F115TLRA - F115TLRZ	2001-2005	18-2385
T50TLRY - C90TLRZ	1989-2001	18-2388	F115TXR	2006 & SUP	18-2385
50ETSK	1984-2001	18-2385	F115TXRA -200ETXN	1984-2004	18-2385
115TLR	2006 & SUP	18-2385	V-6 SPECIAL	1985-1986	18-2385
115TLRA - 115TRR	1991-2005	18-2385	V-6 SPECIAL L	1984-1986	18-2385
115TXR	2006 & SUP	18-2385	V-6 SPECIAL LK	1985	18-2385
115TXRA - 115TXRA	1991-2005	18-2385	V-6 SPECIAL X	1984-1986	18-2385
F115TJR	2006 & SUP	18-2385	V-6 SPECIAL XK	1985	18-2385
F115TJRA - F115TJRD	2002-2005	18-2385			



















18-2773
ALOJAMIENTO COJINETE
Reemplaza: 663-45331-00-94
Para: E48 (1995, 1997-00) / C55 (1991-95)



18-2782
ALOJAMIENTO COJINETE
Reemplaza: 688-45331-00-94
Para: F40 (1999) F50/T50 (1996-00) 60 (2002-03) C60 (1996-01) E60 (1995-99) P60 (1991-99) 70 (1984-03) C70 (2000-01) C75 (1994-96 / 1998-99) E75 (1995-00) P75 (1996-99) C80 (1997) C85 (1991-96)

① Precio por Pack

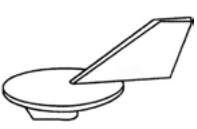
**ZINC para aplicaciones en agua salada.
MAGNESIO solo para aplicaciones en agua dulce.
ALUMINIO para aplicaciones en agua dulce y salada.**

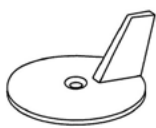
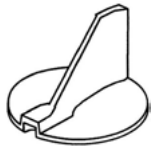
 <p>① 18-6118A Alu. ANODO CILINDRO Reemplaza: 68V-11325-01-00 Para: F75-F250 / 2004 hasta Abril 2006</p>	 <p>① 18-6119A Alu. ③ 18-6119 Zinc ANODO Reemplaza: 61A-45371-00-00</p>	 <p>① 18-6120A Alu. ③ 025961 Zinc ANODO Reemplaza: 61N-45251-01-00</p>	 <p>① 18-6121A Alu. ③ 18-6121Z ANODO Reemplaza: 6K1-45371-02-00 Para: FL150 (2004-2005); L150 - L200 (1987-2002)</p>	 <p>① 18-6122A Alu. ③ 18-6122 Zinc ANODO Reemplaza: 69L-45371-00-00 Para: VZ200 - VZ300 / 3.3L (2005-Actual), VX225 - VX250 / 2.6L (2002-2005), Z250 - Z300 / 3.3L (2004-Actual)</p>
 <p>18-6246 TORNILLO TRIM Reemplaza: 90105-10M00-00 M10 - 1.25 x 45mm dientes</p>	 <p>① 603176 Alu. ③ 025455 Zinc ANODO Reemplaza: K1-45371-00-00 Para usar en la medida inferior 150,200 HP (1986)</p>	 <p>② 18-6112 Mag. ③ 025962 Zinc ANODO Reemplaza: 6J9-45371-01-00 Para: 150-200 HP</p>	 <p>① 18-6111 Alu. ③ 009355 Zinc ANODO Reemplaza: 688-45371-02-00 Para uso en la unidad inferior Para: 60, 70, 90HP (1984-04) C60, C75, C85, C90 (1994-01), E60, E75 (1995-00), F50 (1996-00), P60, P75 (1991-99), T50 (1996-00)</p>	 <p>① 603121 Alu. ③ 025841 Zinc ANODO Reemplaza: 6G5-45251-01-00 Para soporte transom Para: 115-225HP (1988-02)</p>
 <p>① 603120 Alu. ③ 025468 Zinc ANODO Reemplaza: 6H1-45251-02-00 Para: 40-90 HP</p>	 <p>③ 009357 Zinc ANODO Reemplaza: 664-45371-01-00 Para: 20-50 HP</p>	 <p>③ 025304 Zinc ANODO Reemplaza: 6E5-45371-01-00 Para uso de unidad inferior Para: 115, 130 HP(1984-04), V6 especial (1985-86)</p>	 <p>① 603170 Alu. KIT ANODO Para: Yamaha 200-250 Fuerabordas</p>	 <p>① 603171 Alu. KIT ANODO Para: Yamaha 150-200 Fueraborda</p>
 <p>① 603174 Alu. ANODO KIT Para: Yamaha 60-90HP motor</p>	 <p>① 603113 Alu. ANODO Reemplaza: 6E0-45251-11</p>	 <p>① 603115 Alu. ANODO Reemplaza: 6E5-45371-01</p>	 <p>① 603117 Alu. ÁNODO</p>	 <p>① 603119 Alu. ANODO Reemplaza: 6J9-45371-01</p>
 <p>① 603172 Alu. KIT ANODO Para: 150 HP</p>	 <p>① 603175 Alu. ANODO Reemplaza: 6G5-45251-02</p>	 <p>① 603114 Alu. ANODO Reemplaza: 664- 45371-01</p>	 <p>① 603116 Alu. ANODO Reemplaza: 6K1-45371-00</p>	

① Aluminio ② Magnesio ③ Zinc

**ZINC para aplicaciones en agua salada.
MAGNESIO solo para aplicaciones en agua dulce.
ALUMINIO para aplicaciones en agua dulce y salada.**

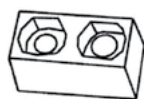

**603118 Alu.
ANODO**
Reemplaza: 6E5-45251-00



**603122 Alu.
ANODO**
Reemplaza: 688-45251-01



**025750 Zinc
ANODO**
Reemplaza: 6H1-45251-01-00



**009355 Zinc
ANODO**
Reemplaza: 688-45371-02-00



**025987 Zinc
ANODO**
Reemplaza: 67F-45371-00-00



**025899 Zinc
ANODO**
Reemplaza: 6G1-45251-03-00



**009110 Zinc
ANODO**
Reemplaza: 65W-45251-00



**025406 Zinc
ANODO**
Reemplaza: 67F-11325-00



**009358 Zinc
ANODO**



**009359 Zinc
ANODO**



**009322 Zinc
ANODO**



**025507 Zinc
ANODO**
Reemplaza: 6T4-45836-00



PASADOR

Ref #	O.E. #	Pack de
18-2380	91490-30030-00, 91401-30030-00, 91401-30028-0010 91402-30028-09, 91402-30028-00, 91402-30022-09 91402-30022-00	
18-3735	91490-40030-00	10
18-3748	91490-30045-00	5
18-73893	91490-25030-00	1



**18-73891
ESPACIADOR HÉLICE**
Reemplaza: 68D-G5987-00-00
Para: Yamaha F2.5(2001 & Sup), F4(2001 & Sup), F6(2006 & Sup)



**18-73914
ESPACIADOR HÉLICE**
Reemplaza: 670-45997-02-00
Para: Yamaha 40-50(1984-05)



**18-73918
ARANDELA HÉLICE**
Reemplaza: 63P-45987-00-00, 6E5-45987-01-00
Para: Yamaha F115-F200(2004-14)



**18-73979
ARANDELA HÉLICE**
Reemplaza: 6L2-45987-01-00
Para: Yamaha 25(1988-09), 30(1990-02), C30(1994-97), F25(1998-14)



**18-73978
ARANDELA TUERCA HÉLICE**
Reemplaza: 90201-08M54-00
Para: Yamaha Multiple Aplicaciones



**18-73990
KIT TUERCA HÉLICE**
Para: Yamaha 40(1984-01), 50(1984-95), C55, F40-F50(1995-00)



**18-73995
KIT TUERCA HELICE**
Reemplaza: 66T-W4599-00-00.
Para: F30(2001-05,2013-19), F40(2000-19), F50(2001-19),F60(2002-19)



**18-73996
KIT TUERCA HELICE**
Reemplaza: 667F-W4599-00-00
Para: T50(2001-18), T60(2003-18), 60(2004-05), 70(2004-09), 90(2004-09), F70(2010-18), F75(2003-17), F80(1999-03), F90(2003-17), F100(1999-03), T50(2001-18), T60(2003-18).



18-73994
KIT TUERCAS HÉLICE
Para: Yamaha F2.5/F4(2001 & sup),
F6(2006 & sup)



18-73892
TUERCAS HÉLICE
Reemplaza: 6L5-45616-00-00
Para: Yamaha 2.5-6(1988 & Sup)



18-3781
KIT TUERCAS HÉLICE
Reemplaza: 6H1-W4599-00-00
Para: T50, C60, E60, P60, 70, C75, C80, C85, 90
— CONTIENE —

Ref #	O.E. #	Descripción
18-3732	90171-16011-00	Tuerca
18-4274	688-45997-01	Espaciador
18-2380	91490-30030	Pasador



18-3782
KIT TUERCAS HÉLICE
Reemplaza: 6G5-W4599-00-00
— CONTIENE —

Ref #	O.E. #	Descripción
18-3726	90171-18M04	Tuerca
18-4274	688-45997-01	Espaciador
18-3735	91490-40030	Pasador

Todos V-4 & V-6 (Excepto D150)



18-3771
KIT TUERCAS HÉLICE
Reemplaza: 689-W4599-00
— CONTIENE —

Ref #	O.E. #	Descripción
18-3791	689-45997-00	Espaciador
18-3792	90171-14013-00	Tuerca hélice
18-2380	91490-30030-00	Pasador



18-3709
TUERCAS HÉLICE
Reemplaza: 647-45616-02
Para: 4(1984-91), 5(1984-85)



18-3726
TUERCAS HÉLICE
Reemplaza: 90171-18M04
Para: Todos V-4 & V-6 (Excepto D150)



18-3732
TUERCA HÉLICE
Reemplaza: 90171-16011-00
95307-16900-00
Para: Yamaha 20-30 hp(1980 & Sup)



18-3773
TUERCA HÉLICE
Reemplaza: 90171-10M01
Para: 6(1986-00), 8(1986-09), 9.9(1984-09),
15(1984-09), F6(2001-08), F8(2001-12),
F9.9(1985-12), F15(1998-13), F20(2006-13)



18-3791
ESPACIADOR
Reemplaza: 689-45997-00



18-3792
TUERCA HÉLICE
Reemplaza: 90171-14013-00,
90171-14056-00



18-79989
STICKS ARRASTRE
Para: Mayoría de fueraborda 150hp con integral tilt/trim.

HP/Modelo	Año	Tuerca #	Espaciador #	Pasador #	Kit #
2(6A1)	1984-95	—	—	18-3748	—
4(6E0)	1984-90	—	—	18-3748	—
4(6E0)	1991	—	—	18-2380	—
5	1984-85	—	—	18-3748	—
9.9(6GB)	1984-85	—	—	18-3748	—
20	1996-97	18-3792	18-3791	18-2380	18-3771
25(6H7)(6L2)	1984-09	18-3792	18-3791	18-2380	18-3771
C25(695)	1991-97	18-3792	18-3791	18-2380	18-3771
CV25	1990	18-3792	18-3791	18-2380	18-3771
F25	1998-05, 2009-10	18-3792	18-3791	18-2380	18-3771
30(689)(6J8)	1984-02	18-3792	18-3791	18-2380	18-3771
C30(689)(61T)	1991-97	18-3792	18-3791	18-2380	18-3771
CV30	1990	18-3792	18-3791	18-2380	18-3771
40(6H4)(63B,C,D)	1984-05	18-3732	—	18-2380	—
C40(6R6)	1990-03	18-3732	—	18-2380/18-3748	—
50(6H5)(62X)	1984-09	18-3732	—	18-2380/18-3748	—
PRO50(6H5)(62X)	1987-90	18-3732	—	18-2380	—
T50	2001-10	18-3732	18-3789	18-3735	18-3772
C55(697)	1991-95	18-3732	—	18-3735	—
60	2004-05	18-3732	18-3789	18-3735	18-3772
P60(6H2)	1991-99	18-3732	18-4274	18-3735	18-3781
T60	2003-10	18-3732	18-3789	18-3735	18-3772
70(6H3)	1984-03	18-3732	18-4274	18-3735	18-3781
70	2004-09	18-3732	18-3789	18-3735	18-3772
F70	2010	18-3732	18-3789	18-3735	18-3772
C75(692)	1994-99	18-3732	18-4274	18-3735	18-3781
F75	2003-10	18-3732	18-3789	18-3735	18-3772
F80	1999-03	18-3732	18-3789	18-3735	18-3772
C85(688)	1991-96	18-3732	18-4274	18-3735	18-3781
90(6H1)	1984-03	18-3732	18-4274	18-3735	18-3781
90	2004-09	18-3732	18-3789	18-3735	18-3772
F90	2003-10	18-3732	18-3789	18-3735	18-3772
F100	1999-03	18-3732	18-3789	18-3735	18-3772
115(6E5)(6N6)	1984-09	18-3726	18-4274	18-3735	18-3782
C115(6E5)	1991-00	18-3726	18-4274	18-3735	18-3782
P115(62A)	1993-96	18-3726	18-4274	18-3735	18-3782
130(6L1)(6N7)	1988-04	18-3726	18-4274	18-3735	18-3782
L130(6L6)(6N4)	1989-01	18-3726	18-4274	18-3735	18-3782
150(6G4)(6R2)	1984-09	18-3726	18-4274	18-3735	18-3782
PRO V 150, (6J9)(6N9)	1986-90	18-3726	18-4274	18-3735	18-3782
P150(6N9)	1991-99	18-3726	18-4274	18-3735	18-3782
L150(6RO)	1986-99	18-3726	18-4274	18-3735	18-3782
175(6G5)(6R3)	1984-00	18-3726	18-4274	18-3735	18-3782
P175(62H)	1994-99	18-3726	18-4274	18-3735	18-3782
200(6G6)(6R4)	1984-95	18-3726	18-4274	18-3735	18-3782
L200(6K1)(6R1)	1987-99	18-3726	18-4274	18-3735	18-3782
P200(61H)	1991-99	18-3726	18-4274	18-3735	18-3782
225(6R5)(62J)	1990-97	18-3726	18-4274	18-3735	18-3782
L225(62K)	1994-99	18-3726	18-4274	18-3735	18-3782
250(61A)	1990-95	18-3726	18-4274	18-3735	18-3782
L250(61B)	1990-99	18-3726	18-4274	18-3735	18-3782
V6 SPECIAL(6G7)	1984-86	18-3726	18-4274	18-3735	18-3782
V6 EXCEL(6K7)	1987-89	18-3726	18-4274	18-3735	18-3782

① Referencias acabadas en "D" Envasadas
② Precio por pieza. Precio pack, añadir -9 a la referencia.

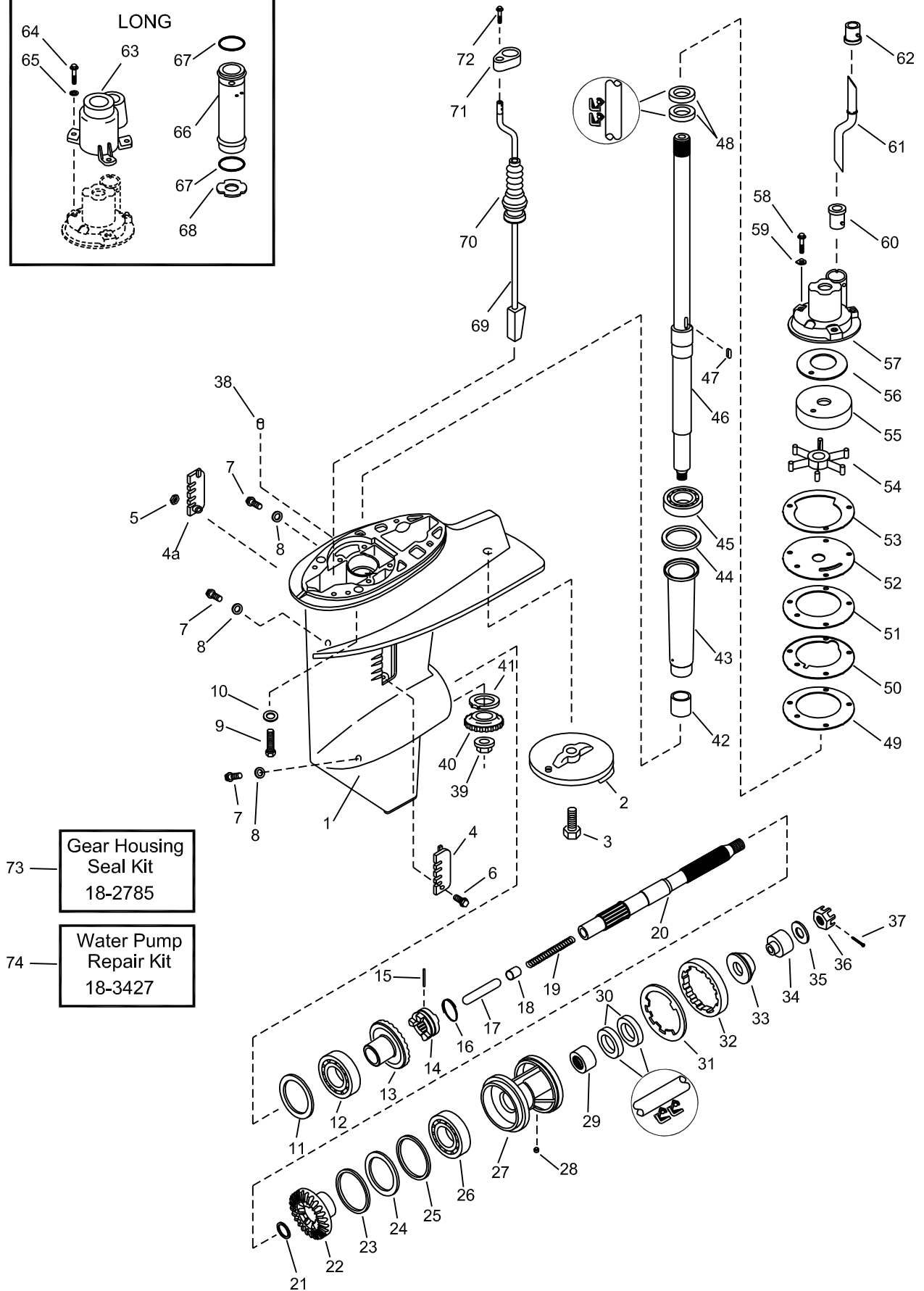
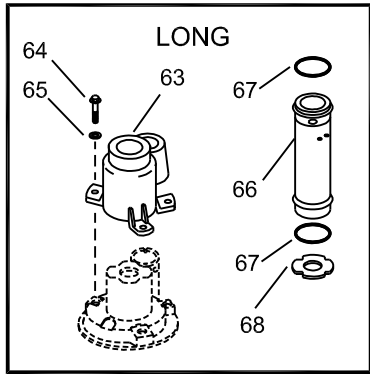

Fig. #	Descripción	Ref #	O.E.M. #	Cant.	Fig. #	Descripción	Ref #	O.E.M. #	Cant.
1	Alojamiento	—	689-45311-04-EK3	1	37	Pasador	18-2380	91490-30030-00	
2	Tapón	18-6096A 009357	664-45371-01-00	1	38	Pasador	—	93606-12019-00	2
					39	Tuerca, Piñón	—	90179-09M02-00	2
3	Tornillo Trim Tab	—	90105-08M02-00	1	40	Engranajes, Piñón	—	689-45551-00-00	1
4	Tapón, Entrada agua (babor)	—	689-45214-01-01	1	41	Cojinete, empuje	—	664-45552-09-00	1
4a	Tapón, Entrada de agua (Estr.)	—	689-45215-01-00	1	42	Cojinete, Piñón	—	93315-017U4-00	1
5	Tuerca, Nylock	—	90185-05904-00	1	43	Casquillo	—	689-45536-00-00	1
6	Tornillo, Entrada de agua	—	98680-05525-00	1	44	Engranaje piñón (0.5mm)	—	664-45587-00-05	AR
7	Tapón, Drenaje & Vent.	—	90340-08M04-00	3		Engranaje piñón (0.8mm)	—	664-45587-00-08	AR
8	Junta, Tapón	—	90430-08020-00	3		Engranaje piñón (0.12mm)	—	664-45587-01-12	AR
9	Tornillo, Caja engranajes montaje	—	90105-10059-00	2		Engranaje piñón (0.30mm)	—	664-45587-01-30	AR
10	Arandela, Caja engranaje	—	92990-10600-00	4		Engranaje piñón (0.50mm)	—	664-45587-01-50	AR
11	Engranaje delantero (0.5mm)	—	664-45567-00-05	AR	45	Cojinete, Eje transmisión	—	93332-000U4-00	1
	Engranaje delantero (0.8mm)	—	664-45567-00-08	AR	46	Eje transmisión (largo)	—	689-45501-10-00	1
	Engranaje delantero (0.12mm)	—	664-45567-01-12	AR	47	Llave, Impulsor	—	664-44338-00-00	1
	Engranaje delantero (0.30mm)	—	664-45567-01-30	AR	48	Retén aceite, Base bomba	18-0296	93101-22067-00	2
	Engranaje delantero (0.50mm)	—	664-45567-01-50	AR	49	Junta, Base	18-0773	689-44316-A0-00	1
12	Cojinete, engranaje delantero	—	93332-00005-00	1	50	Base, bomba agua	—	689-44325-02-5B	1
13	Engranaje, delantero	—	689-45560-00-00	1	51	Junta, Base	18-0773	689-44316-A0-00	1
14	Acoplamiento	—	664-45631-01-00	1	52	Impulsor platina	—	689-44323-03-00	1
15	Pasador	—	90250-05010-00	1	53	Junta, Impulsor platina	—	689-44324-A0-00	1
16	Aro	—	648-45633-00-00	1	54	Impulsor	18-3067	689-44352-02-00	1
17	Embolo	—	648-45635-00-00	1	55	Casquillo	18-3439	689-W4432-02-00	1
18	Arandela	—	648-45634-00-00	1	56	Damper, Retén agua	—	689-44367-01-00	1
19	Muelle, Compresión	—	90501-10065-00	1	57	Alojamiento, Bomba agua	—	689-44311-03-00	1
20	Eje, hélice	—	689-45611-00-00	1	58	Tornillo, bomba alojamiento	—	90101-06M56-00	3
21	Empuje, Arandela, Prop Shaft	—	90201-20417-00	1	59	Arandela, Alojamiento (eje corto)	—	90209-06M04-00	3
22	Engranaje, Reverso	—	689-45571-00-00	1	60	Retén, tubo inf agua	—	626-44365-01-00	1
23	Engranaje reverso (0.5mm)	—	664-45577-00-05	AR	61	Tubo agua (Eje largo)	—	689-44361-10-00	1
	Engranaje reverso (0.8mm)	—	664-45577-00-08	AR	62	Retén, tubo agua superior	18-0552	689-44366-00-00	1
	Engranaje reverso (0.12mm)	—	664-45577-01-12	AR	63	Extensión, Alojamiento (eje largo)	—	689-44312-00-5B	1
	Engranaje reverso (0.30mm)	—	664-45577-01-30	AR	64	Tornillo, Extensión (eje largo)	—	97080-06035-00	3
	Engranaje reverso (0.50mm)	—	664-45577-01-50	AR	65	Arandela, tornillo (Eje largo)	—	92990-06600-00	3
24	Arandela empuje	—	664-45576-00-00	1	66	Tubo extensión (Eje largo)	—	689-44362-00-94	1
25	Aro, Cojinete transportador	—	93210-30MA3-00	1	67	Aro, Tubo extensión	—	93210-26240-00	2
26	Cojinete, Reverso engranaje	—	93306-00612-00	1	68	Platina (Eje largo)	—	689-44328-03-00	1
27	Cojinete, transportador	—	689-45331-01-94	1	69	Ensamblaje (eje corto)	—	664-44150-01-00	1
28	Llave	—	90282-04010-00	1	69	Ensamblaje (eje largo)	—	664-44150-11-00	1
29	Cojinete, eje hélice	—	93315-22004-00	1	70	Boot	—	664-44147-00-00	1
30	Retén, eje hélice	18-0554	93101-20M07-00	2	71	Soporte	—	689-44176-01-00	1
31	Tapón arandela	—	90214-45M02-00	1	72	Tornillo, Sопorte	—	97780-50610-00	1
32	Tuerca, Tapón	—	664-45384-00-00	1	73	Kit retenes de la caja de engr.	18-2785	689-W0001-22-00	1
33	Espaciador (ant)	—	664-45987-01-00	1	74	Kit bomba agua reparación	18-3427	689-W0078-A6-00	1
34	Espaciador (post)	—	689-45997-00-00	1					
35	Arandela, montaje hélice	—	92990-14200-00	1					
36	Tuerca, hélice	—	90171-14013-00	1					
AR Se requiere									

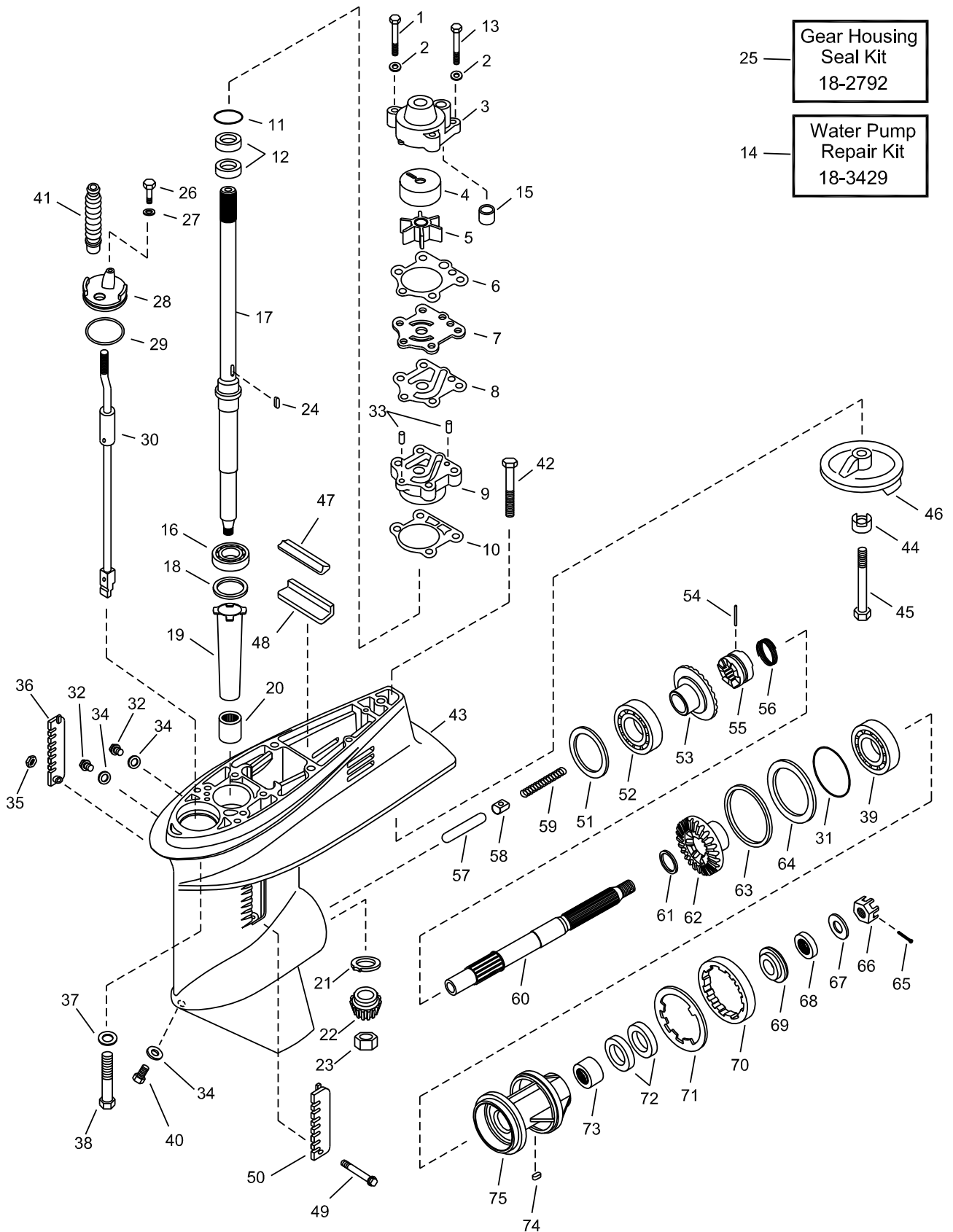
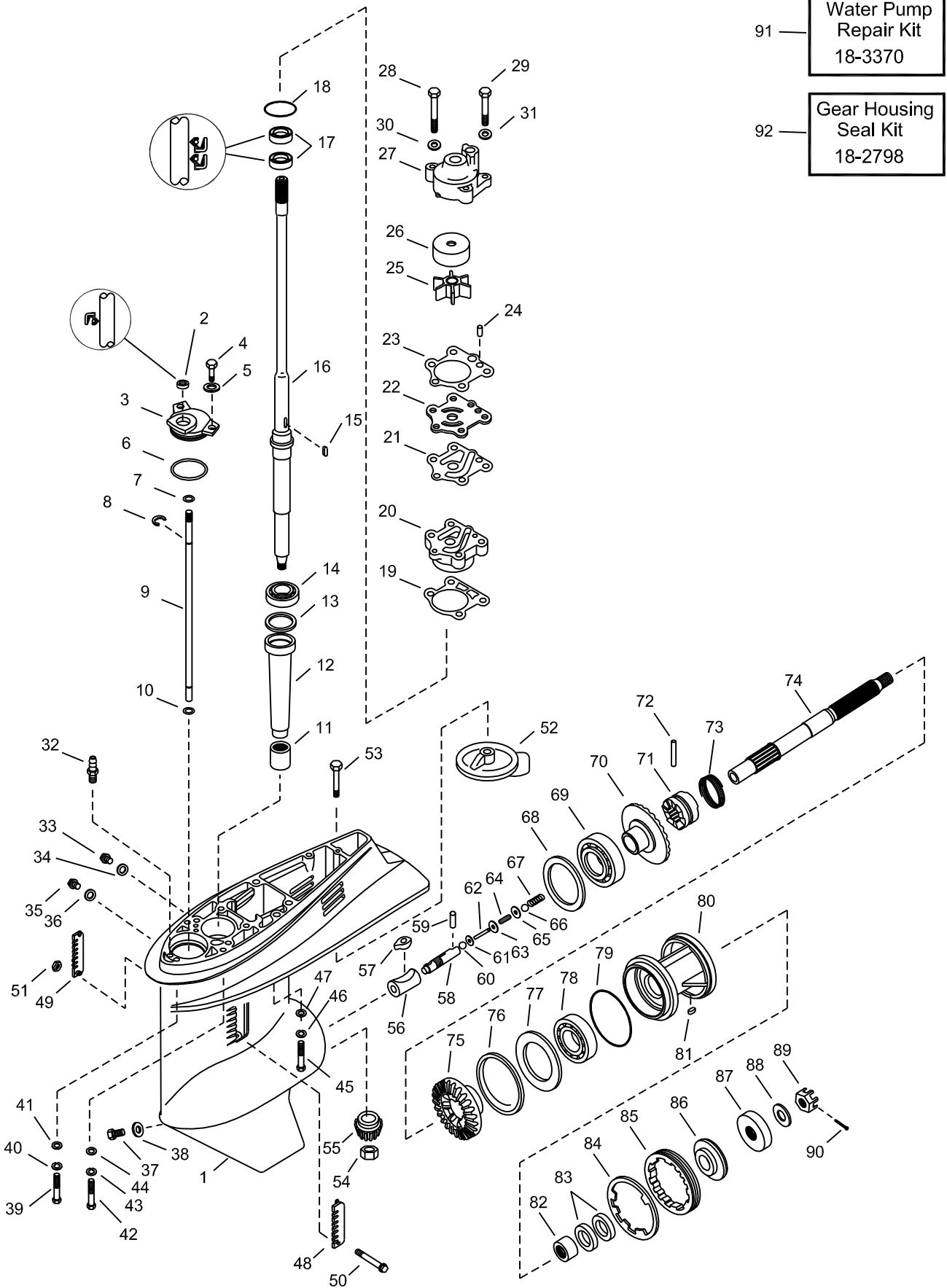

Fig. #	Descripción	Ref #	O.E.M. #	Cant.	Fig. #	Descripción	Ref #	O.E.M. #	Cant.
1	Tornillo, bomba agua alojamiento	—	97395-08055-00	2	39	Cojinete bola	—	93306-00702-00	1
2	Arandela, bomba agua aloj.	—	92990-08600-00	4	40	Tapón, Drenaje	18-2374	688-45341-00-00	1
3	Alojamiento, Bomba agua	—	663-44311-02-00	1	41	Hélice	—	various	1
4	Insert, Bomba agua	18-3435	663-44322-00-00	1	42	Tornillo, Trim Tab	—	97575-08675-00	1
5	Impulsor	18-3068	6H4-44352-02-00	1	43	Cola inf	—	6H4-45301-01-EK	1
6	Junta, bomba agua platina	18-0292	663-44315-A0-00	1	44	Arandela, cierre	—	92990-08100-00	1
					45	Tornillo inf	—	97095-08085-00	1
7	Placa de desgaste, Bomba agua	18-3436	663-44323-00-00	1	46	Tapón Trim	009357	664-45371-01-00	1
8	Junta, bomba agua platina	18-0294	663-44324-A0-00	1	47	Retén	—	688-45375-00-00	1
					48	Retén goma	—	663-45376-00-94	1
9	Base, bomba agua	—	663-44341-00-94	1	49	Tornillo	—	98780-05535-00	1
10	Junta, bomba Base	—	663-44316-A0-00	1	50	Tapón, entrada de agua (babor)	—	668-45214,02-00	1
11	Aro, bomba base	18-0298	93210-41042-00	1	51	Arandela engranaje (0.5mm)	—	6H4-45567-00-05	1
12	Retén aceite, base bomba	18-0297	93101-23070-00	2		Arandela engranaje (0.8mm)	—	6H4-45567-00-08	AR
13	Tornillo, Bomba agua alojamiento	18-0256	97095-08045-00	2		Arandela engranaje (0.12mm)	—	6H4-45567-01-12	AR
14	Kit reparación bomba agua	18-3429	6H4-W0078-00-00	1		Arandela engranaje (0.30mm)	—	6H4-45567-01-30	AR
15	Retén agua	—	663-44366-00-00	1		Arandela engranaje (0.50mm)	—	6H4-45567-01-50	AR
16	Cojinete, rodillo cónico	—	93332-00079-00	1	52	Engranajes, rodillo cónico	—	93332-000V4-00	1
17	Eje transmisión (Corto)	—	6H4-45501-00-00	1	53	Engranajes	—	6H4-45560-00-00	1
17	Eje transmisión (Largo)	—	6H4-45501-10-01	1	54	Pasador	—	90250-06023-00	1
18	Arandela (0.5mm)	—	663-45587-00-05	AR	55	Embrague, Sliding	—	663-45631-01-00	1
	Arandela (0.8mm)	—	663-45587-00-08	AR	56	Aro retenedor, Pasador	—	663-45633-00-00	1
	Arandela (0.12mm)	—	663-45587-01-12	AR	57	Embolo	—	676-45635-00-00	1
	Arandela (0.30mm)	—	663-45587-01-30	AR	58	Fijador	—	663-45634-00-00	1
	Arandela (0.50mm)	—	663-45587-01-50	AR	59	Muelle, Compresión	—	60501-16M01-00	1
19	Casquillo, Eje transmisión	—	6H4-45536-00-0	1	60	Eje	—	679-45611-01-00	1
20	Cojinete de aguja	—	93315-32224-00	1	61	Arandela, Platina	—	90201-22429-00	1
21	Cojinete (no usado 1988 & después)	—	663-45552-00-00	1	62	Engranajes, Reverso	—	6H4-45571-00-00	1
22	Engranaje, Piñon	—	6H4-45551-00-00	1	63	Arandela engranaje reverso (0.5mm)	—	663-45577-00-05	AR
23	Tuerca, Piñon engranaje	—	90170-12138-00	1		Arandela engranaje reverso (0.8mm)	—	663-45577-00-08	AR
24	Llave, Woodruff	18-3305	90280-03024-00	1		Arandela engranaje reverso (0.12mm)	—	663-45577-01-12	AR
25	Kit retén caja engranaje	18-2792	6H4-W0001-20-00	1		Arandela engranaje reverso (0.3mm)	—	663-45577-01-30	AR
26	Tornillo, Platina	—	97095-06016-00	1		Arandela engranaje reverso (0.5mm)	—	663-45577-01-50	AR
27	Arandela, Platina	—	92990-06600-00	1	64	Arandela empuje	—	663-45576-00-00	1
28	Platina	—	6H4-45321-01-00	1	65	Pasador	18-2380	91490-30030-00	1
29	Aro, Platina	—	93210-49046-00	1	66	Tuerca	18-3732	90171-16011-11	1
30	Ensamblaje (eje corto)	—	6H4-44150-01-00	1	67	Arandela	—	92990-16200-00	1
	Ensamblaje (eje largo)	—	6H4-44150-12-01	1	68	Espaciador, Montaje hélice (ant)	—	670-45997-02-00	1
31	Aro, Cojinete alojamiento	18-0299	93210-66M98-00	1	69	Espaciador, Montaje hélice (post)	—	663-45987-02-00	1
32	Tapón, Vent.	—	90340-08M04-00	2	70	Tuerca, Tapón	—	697-45385-00-00	1
33	Pasador	—	93604-08062-00	2	71	Arandela, Tapón	—	90214-48M03-00	1
34	Junta, Tapón drenaje	—	90430-08020-00	3	72	Retén aceite, Cojinete alojamiento	18-0296	93101-22067-00	2
35	Tuerca, Nylock	—	90185-05904-00	1	73	Cojinete aguja	—	93317-22204-00	1
36	Tapón, Entrada de agua (estr)	—	688-45215-02-00	1	74	Llave, cojinete alojamiento	—	90282-04010-00	1
37	Arandela, Cierre	—	92990-10100-00	4	75	Alojamiento, Cojinete	—	679-45331-00-94	1
38	Tornillo	—	97078-10040-00	4					

AR Se requiere



- 91 — Water Pump Repair Kit 18-3370
- 92 — Gear Housing Seal Kit 18-2798

Fig. #	Descripción	Ref #	O.E.M. #	Cant.	Fig #	Descripción	Ref #	O.E.M. #	Cant.
1	Caja engranajes	—	6H1-45301-04-EK	1	50	Tornillo, entrada de agua	—	98680-05545-00	1
2	Retén aceite, Eje cambio	18-0267	93106-09014-00	1	51	Tuerca, Entrada de agua	—	90185-05002-00	1
3	Platina, Varilla de cambio	—	688-45321-00-00	1	52	Trim Tab	009355	988-45371-02-00	1
4	Tornillo, Ret. de varilla de camb.	—	97395-06016-00	2	53	Tornillo, Anodo montaje	—	90105-10M00-00	1
5	Arandela	—	92990-06600-00	2	54	Tuerca, Piñon	—	90170-16M01-00	1
6	Aro	—	93210-49046-00	1	55	Engranajes, Piñon	—	688-45551-01-00	1
7	Aro	—	93210-07540-01	1	56	Casquillo	—	6H1-45641-01-00	1
8	Anillo de retención	—	99001-08600-00	1	57	Casquillo	—	6H1-44151-00-00	1
9	Varilla	—	6H1-44144-00-00	1	58	Casquillo	—	6H1-45634-02-00	1
10	Clip	—	93450-07M00-00	1	59	Pasador	—	93603-12M11-00	1
11	Cojinete, Piñon	—	93315-325V1-00	1	60	Tuerca, Muelle	—	90183-02M03-00	1
12	Casquillo, Eje transmisión	—	688-45536-01-00	1	61	Arandela	—	6H1-45635-00-00	1
13	Arandela (0.10mm)	—	688-45587-01-10	AR	62	Eje	—	6H1-45668-00-00	1
	Arandela (0.12mm)	—	688-45587-01-12	AR	63	Arandela	—	6H1-45635-00-00	1
	Arandela (0.15mm)	—	688-45587-01-15	AR	64	Muelle, Compresión	—	90501-12M48-00	1
	Arandela (0.18mm)	—	688-45587-01-30	AR	65	Arandela platina	—	90201-03313-00	1
	Arandela (0.30mm)	—	688-45587-01-40	AR	66	Tuerca, Muelle	—	90183-02M03-00	1
	Arandela (0.40mm)	—	688-45587-01-50	AR	67	Muelle, Compresión	—	90501-16M65-00	1
	Arandela (0.50mm)	—	688-45587-01-16	AR	68	Arandela engranaje (0.10mm)	—	688-45567-01-10	AR
14	Cojinete, Eje transmisión sup.	—	93332-000U3-00	1		Arandela engranaje (0.12mm)	—	688-45567-01-12	AR
15	Llave, Impulsor	18-3301	90280-04M04-00	1		Arandela engranaje (0.15mm)	—	688-45567-01-15	AR
16	Eje transmisión	—	6H1-45501-11-00	1		Arandela engranaje (0.18mm)	—	688-45567-01-18	AR
17	Retén aceite, bomba base	18-0587	93101-25M03-00	2		Arandela engranaje (0.30mm)	—	688-45567-01-30	AR
18	Aro, Base	18-7436	9321-46044-00	1		Arandela engranaje (0.40mm)	—	688-45567-01-40	AR
19	Junta, Base	18-0240	688-44316-A0-00	1		Arandela engranaje (0.50mm)	—	688-45567-01-50	AR
20	Base, bomba agua	—	688-44341-01-94	1	69	Cojinete	—	93332-000W7-00	1
21	Junta, placa de desgaste a base	—	688-44324-A0-00	1	70	Engranajes	—	688-45560-00-00	1
22	Placa desgaste	18-3341	688-44323-00-00	1	71	Tuerca	—	6H1-45631-01-00	1
23	Junta, placa desgaste alojamiento	18-0239	688-44315-A0-00	1	72	Pasador	—	90250-07M02-00	1
24	Pasador	—	93604-10M03-00	1	73	Muelle, Pasador	—	688-45633-00-00	1
25	Impulsor	18-3070	688-44352-03-00	1	74	Eje, hélice	—	6H1-45611-01-00	1
26	Bomba agua	—	688-44322-00-00	1	75	Engranaje, Reverso	—	6H1-45571-00-00	1
27	Bomba agua alojamiento	18-3171	688-44311-01-00	1	76	Arandela eng. reverso (0.10mm)	—	688-45577-01-10	AR
28	Tornillo, bomba agua	—	97395-08070-00	2		Arandela eng. reverso (0.12mm)	—	688-45577-01-12	AR
29	Tornillo, bomba agua	—	97395-08050-00	2		Arandela eng. reverso (0.15mm)	—	688-45577-01-15	AR
30 &						Arandela eng. reverso (0.18mm)	—	688-45577-01-18	AR
31	Arandela, Bomba agua	—	90209-08M02-00	4		Arandela eng. reverso (0.30mm)	—	688-45577-01-30	AR
32	Conector manguera	—	6E5-45378-00-00	1		Arandela eng. reverso (0.40mm)	—	688-45577-01-40	AR
33	Tapón, Drenaje	18-2371	90340-08M04-00	1		Arandela eng. reverso (0.50mm)	—	688-45577-01-50	AR
34	Junta, Vent. & Tapones drenaje	8-46981-9	90430-08020-00	1	77	Arandela empuje	—	688-45576-00-00	1
35	Tapón, Drenaje	18-2371	90340-08M04-00	1	78	Cojinete, engranaje reverso	—	93306-207U0-00	1
36	Junta, Vent. & tapones drenaje	8-46981-9	90430-08020-00	1	79	Aro, Cojinete alojamiento	—	93210-85M97-00	1
37	Tapón, Drenaje	18-2374	688-45341-00-00	1	80	Cojinete alojamiento	18-2782	688-45331-00-94	1
38	Junta, Vent & tapones drenaje	8-46981-9	90430-08020-00	1	81	Llave	—	90282-04010-00	1
39	Tornillo	—	97395-10040-00	2	82	Cojinete aguja	—	93317-325U0-00	1
40	Arandela, Cierre	—	92990-10100-00	2	83	Retén aceite	18-0587	93101-25M03-00	2
41	Arandela	—	92990-10600-00	2	84	Arandela, Tapón	—	688-45383-02-00	1
42	Tornillo	—	97395-10040-00	2	85	Tuerca, Tapón	—	688-45384-00-00	1
43	Arandela, Cierre	—	92990-10100-00	2	86	Espaciador	—	688-45987-01-00	1
44	Arandela, Cierre	—	92990-10600-00	2	87	Espaciador	18-4274	688-45997-01-00	1
45	Bolt	—	97395-08060-00	1	88	Arandela hélice	—	90201-17M00-00	1
46	Arandela, Lock	—	92990-08100-00	1	89	Tuerca	18-3732	90171-16011-00	1
47	Arandela, Lock	—	92990-08100-00	1	90	Pasador	18-3735	91490-40030-00	1
48	Tapones, Entrada de agua (babor)	—	688-45214-02-00		91	Kit reparación bomba agua	18-3370	692-W0078-00-00	1
49	Tapón, entrada de agua (estr)	—	688-45215-02-00	1	92	kit retén engranajes alojamiento	18-2798	688-W0001-20-00	1

AR Se requiere

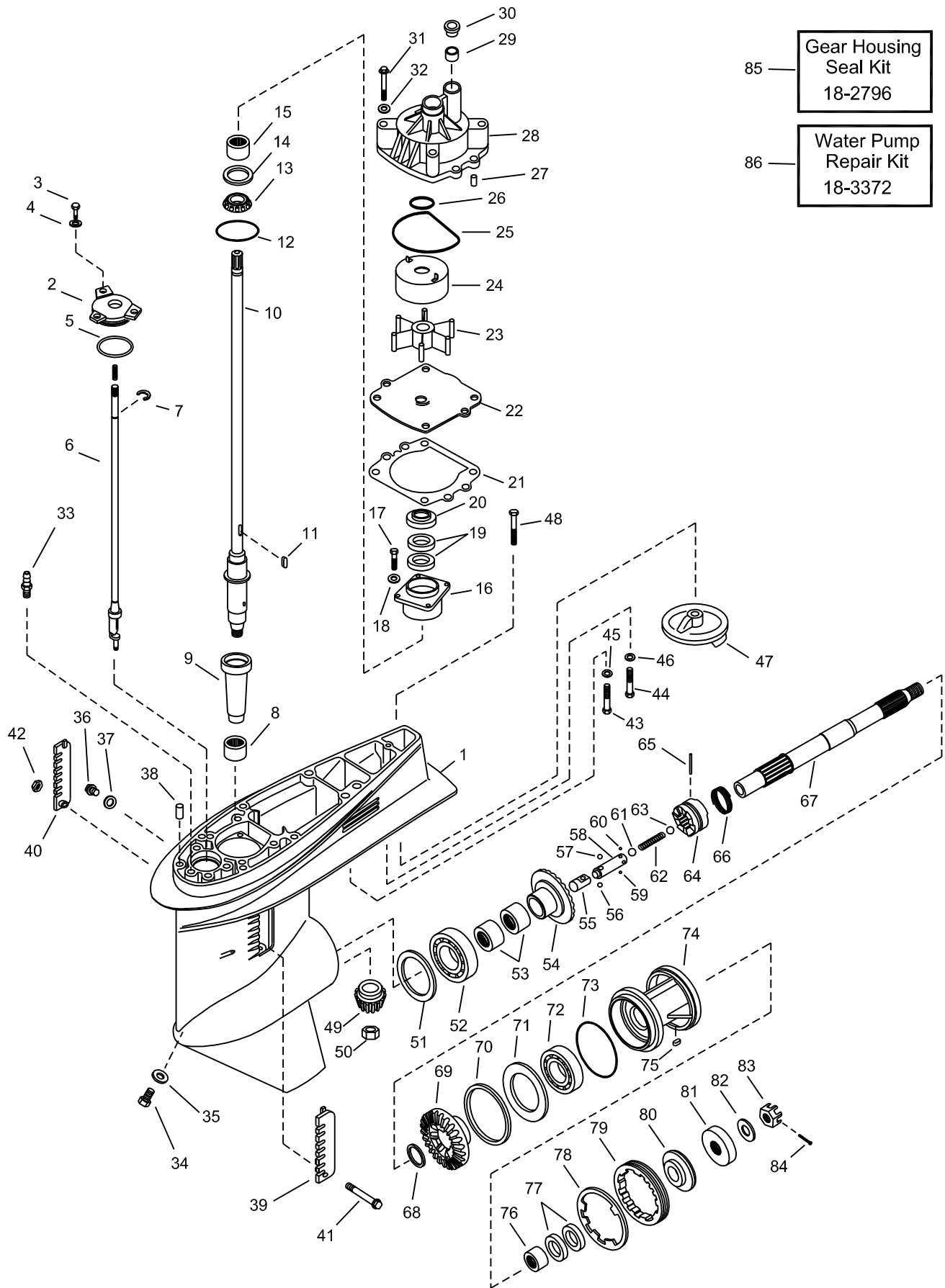

Fig. #	Descripción	Ref #	O.E.M. #	Cant.	Fig. #	Descripción	Ref #	O.E.M. #	Cant.
1	Caja engranajes alojamiento	—	6E5-45301-03EK	1	47	Tapón	025304	6E5-45371-01-00	1
2	Platina	—	6E5-45321-00-00	1	48	Tornillo, Trim Tab	—	90105-10M00-00	1
3	Tornillo	—	97395-06020-00	3	49	Engranaje piñon	—	6E5-45551-02-00	1
4	Arandela	—	90209-06M04-00	3	50	Tuerca piñon	—	90170-16M01-00	1
5	Aro, Platina	—	93210-5867-00	1	51	Arandela (0.10mm)	—	6E5-45567-01-10	AR
6	Varilla	—	6E5-44150-01-00	1		Arandela (0.12mm)	—	6E5-45567-01-12	AR
7	Anillo de retención	—	99001-08600-00	1		Arandela (0.15mm)	—	6E5-45567-01-15	AR
8	Cojinete aguja	—	93315-628U9-00	1		Arandela (0.18mm)	—	6E5-45567-01-18	AR
9	Casquillo, eje transmisión	—	6E5-45536-00-00	1		Arandela (0.30mm)	—	6E5-45567-01-30	AR
10	Eje transmisión (largo)	—	6E5-45501-01-00	1		Arandela (0.40mm)	—	6E5-45567-01-40	AR
	Eje transmisión (x-largo)	—	6E5-45501-21-00	1		Arandela (0.50mm)	—	6E5-45567-01-50	AR
11	Llave, Impulsor	—	90280-04M05-00	1	52	Cojinete	—	93332-000U7-00	1
12	Aro, Alojamiento	—	93210-54534-00	1	53	Cojinete aguja	—	93315-425U7-00	2
13	Cojinete cónico	—	93341-930U0-00	1	54	Engranajes	—	6E5-45560-01-00	1
14	Arandela (0.10mm)	—	6E5-45587-01-10	AR	55	Casquillo	—	6E5-45641-01-00	1
	Arandela (0.12mm)	—	6E5-45587-01-12	AR	56	Bola de retención	—	93507-32031-00	1
	Arandela (0.15mm)	—	6E5-45587-01-15	AR	57	Bola de retención	—	93507-32031-00	1
	Arandela (0.18mm)	—	6E5-45587-01-18	AR	58	Casquillo	—	6E5-45634-01-00	1
	Arandela (0.30mm)	—	6E5-45587-01-30	AR	59	Bola de retención	—	93503-16010-00	1
	Arandela (0.40mm)	—	6E5-45587-01-40	AR	60	Bola de retención	—	93503-16010-00	1
	Arandela (0.50mm)	—	6E5-45587-01-50	AR	61	Bola de retención	—	93511-32027-00	1
15	Cojinete aguja	—	93315-430V5-00	1	62	Muelle, Compresión	—	90501-16M37-00	1
16	Cojinete alojamiento	—	6E5-45331-0094	1	63	Bola de retención	—	93511-32027-00	1
17	Tornillo, cojinete alojamiento	—	97395-08025-00	4	64	Tuerca	—	6R5-45631-01-00	1
18	Arandela	—	92990-08600-00	4	65	Pasador	—	90250-08M07-00	1
19	Retén, eje transmisión	18-0265	93101-28M16-00	2	66	Retenedor, Pasador	—	6E5-45631-01-00	1
20	Tapón, Retén aceite	—	6E5-45344-00-00	1	67	Eje, Propeller	18-2385	6E5-45611-01-00	1
21	Junta, platina	18-0244	6E5-44315-A0-00	1	68	Arandela de empuje	—	90201-30M92-00	1
22	Placa desgaste	18-3344	6G5-44323-00-00	1	69	Engranajes, Reverso	—	6E5-45571-04-00	1
23	Impulsor	18-3071	6E5-44352-00-00	1	70	Arandela (0.10mm)	—	6L6-45577-00-10	AR
24	Insertar bomba agua	—	6E5-44322-00-00	1		Arandela (0.12mm)	—	6L6-45577-00-12	AR
25	Aro, bomba agua	18-7485	93210-86M38-00	1		Arandela (0.15mm)	—	6L6-45577-00-15	AR
26	Aro, bomba agua	18-7483	93210-37M67-00	1		Arandela (0.18mm)	—	6L6-45577-00-18	AR
27	Pasador, bomba agua alojamiento	—	93606-12019-00	2		Arandela (0.30mm)	—	6L6-45577-00-30	AR
28	Bomba agua alojamiento	18-3170	6E5-44311-00-00	1		Arandela (0.40mm)	—	6L6-45577-00-40	AR
29	Damper, Retén agua	—	6E5-44365-00-00	1		Arandela (0.50mm)	—	6L6-45577-00-50	AR
30	Tapa, bomba alojamiento	—	6E5-44312-00-0	1	71	Arandela empuje	—	6E5-45576-00-00	1
31	Tornillo, bomba agua	—	97080-08045-00	4	72	Cojinete, engranaje reverso	—	93306-208U0-00	1
32	Arandela	—	90209-08M02-00	4	73	Aro, cojinete alojamiento	—	93210-86M39-00	1
33	Conector, manguera	—	6E5-45378-00-00	1	74	Cojinete alojamiento	—	6E5-45332-00-94	1
34	Tapón inferior drenaje	18-2374	688-45341-00-00	1	75	Llave, Cojinete alojamiento	—	90282-04010-00	1
35	Junta, tapón drenaje	18-4698	90430-08020-00	1	76	Cojinete aguja	—	93315-430U8-00	1
36	Tapón drenaje superior	—	90340-08M04-00	1	77	Retén, eje hélice	18-0266	93101-30M17-00	2
37	Junta, tapón drenaje	18-4698	90430-08020-00	1	78	Arandela, Tapón	—	688-45383-02-00	1
38	Pasador	—	93608-12M05-00	2	79	Tuerca, tapón	—	688-45384-00-00	1
39	Tapón, Entrada de agua (babor)	—	688-45214-02-00	1	80	Arandela de empuje	—	6E5-45987-01-00	1
40	tapón entrada de agua (estr)	—	688-45215-02-00	1	81	Espaciador, hélice	18-4274	688-45997-01-00	1
41	Tornillo, entrada de agua	—	90142-05M03-00	1	82	Arandela, hélice	—	92990-18200-00	1
42	Tuerca entrada de agua	—	90185-05002-00	1	83	Tuerca, hélice	18-3726	90171-18M04-00	1
43	Tornillo	—	97395-10070-00	1	84	Pasador	18-3735	91490-40030-00	1
44	Tornillo	—	97395-10070-00	1	85	Kit retén engranajes alojamiento	18-2796	6E5-W0001-51-00	1
45	Arandela	—	92990-10100-00	1	86	Kit reparación bomba de agua	18-3372	6E5-W0078-00-00	1
46	Arandela	—	92990-10100-00	1					

AR Se requiere

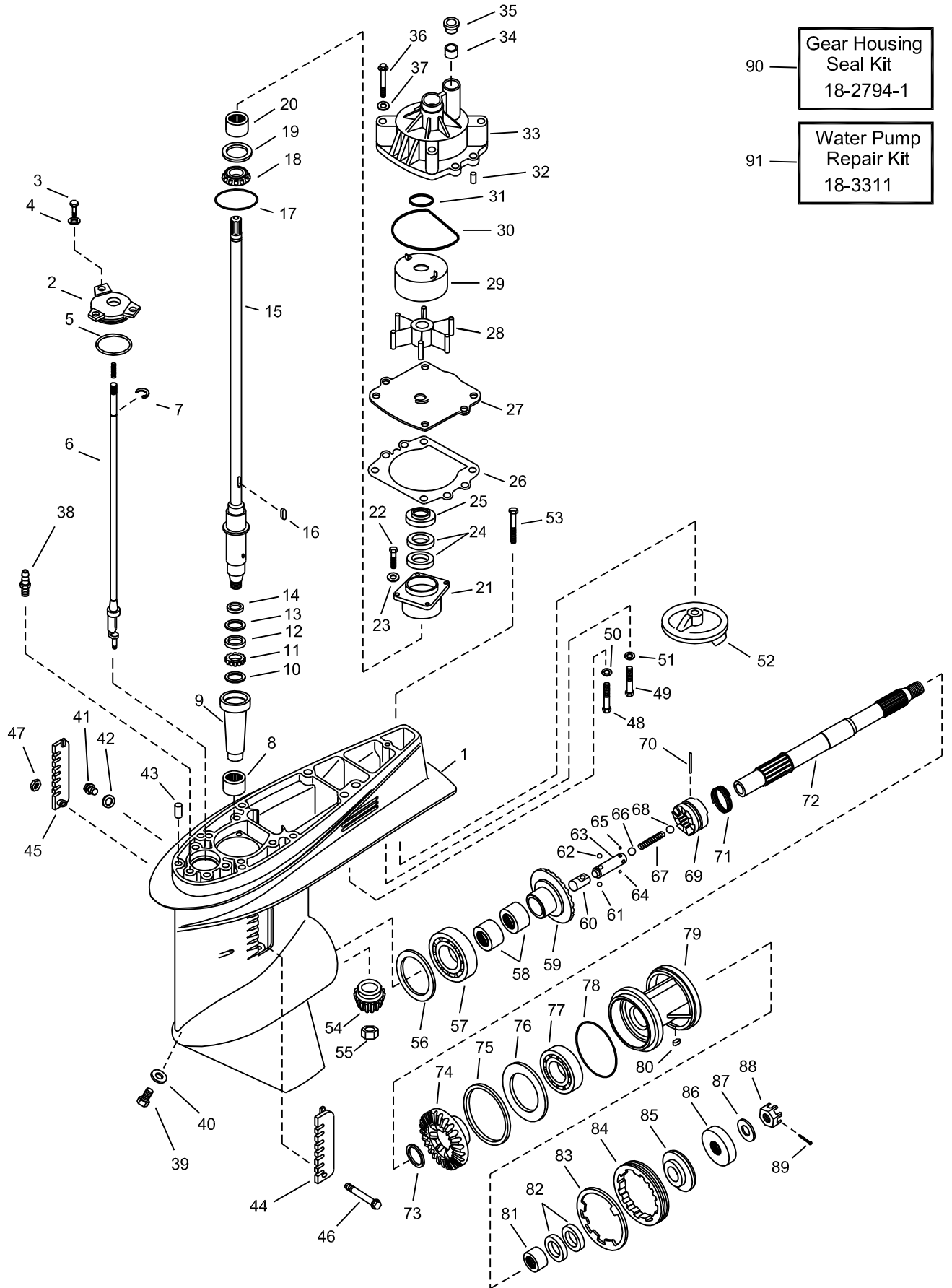

Fig. #	Descripción	Ref #	O.E.M. #	Cant.	Fig. #	Descripción	Ref #	O.E.M. #	cant.
1	Alojamiento, Caja engranajes	—	6J9-45301-02-Ek	1	49	Tornillo	—	97395-10070-00	1
2	Platina	—	6E5-45321-00-00	1	50	Arandela	—	92990-10100-00	1
3	Tornillo	—	97395-06020-00	3	51	Arandela	—	92990-10100-00	1
4	Arandela	—	90209-06M04-00	3	52	Trim Tab	025962	6J9-45371-01-00	1
5	Aro, Platina	—	93210-58677-00	1	53	Tornillo, Trim Tab	—	90105-10M00-00	1
6	Varilla	—	6G5-44150-01-00	1	54	Piñon engranaje	—	6G5-45551-01-00	1
7	Anillo retención	—	99001-08600-00	1	55	Tuerca, Piñon	—	90170-16M01-00	1
8	Cojinete cónico	—	90250-08M07-00	1	56	Arandela (0.10mm)	—	6G5-45567-01-10	AR
9	Casquillo, eje transmisión	—	6G5-45536-01-00	1		Arandela (0.12mm)	—	6G5-45567-01-12	AR
10	Arandela	—	90209-33M13-00	1		Arandela (0.15mm)	—	6G5-45567-01-15	AR
11	Muelle, Compresión	—	90501-05M64-00	AR		Arandela (0.18mm)	—	6G5-45567-01-30	AR
12	Collar	—	90387-33M00-00	1		Arandela (0.30mm)	—	6G5-45567-01-40	AR
13	Arandela	—	90209-33M13-00	1		Arandela (0.40mm)	—	6G5-45567-01-50	AR
14	Arandela	—	90209-33M12-00	1		Arandela (0.50mm)	—	6G5-45567-01-10	AR
15	Eje transmisión (largo)	—	6G5-45501-01-00	1	57	Cojinete	—	93332-00V3-00	1
	Eje transmisión (x-largo)	—	6G5-45501-21-00	1	58	Cojinete aguja	—	93315-425V3-00	2
16	Llave, Impulsor	—	90280-04M05-00	1	59	Engranaje, Forward	—	6G5-45631-00-00	1
17	Aro, alojamiento	—	93210-54534-00	1	60	Casquillo	—	6E5-45641-01-00	1
18	Cojinete cónico	—	93341-930U0-00	1	61	Bola de retención	—	93507-32031-00	1
19	Arandela (0.10mm)	—	6E5-45587-01-10	AR	62	Bola de retención	—	93507-32031-00	1
	Arandela (0.12mm)	—	6E5-45587-01-12	AR	63	Casquillo	—	6E5-45634-01-00	1
	Arandela (0.15mm)	—	6E5-45587-01-15	AR	64	Bola de retención	—	93503-16010-00	1
	Arandela (0.18mm)	—	6E5-45587-01-18	AR	65	Bola de retención	—	93503-16010-00	1
	Arandela (0.30mm)	—	6E5-45587-01-30	AR	66	Bola de retención	—	93511-32027-00	1
	Arandela (0.40mm)	—	6E5-45587-01-40	AR	67	Muelle, Compresión	—	90501-16M37-00	1
	Arandela (0.50mm)	—	6E5-45587-01-50	AR	68	Bola de retención	—	93511-32027-00	1
20	Cojinete aguja	—	93315-430V5-00	1	69	Tuerca	—	6E5-45633-01-00	1
21	Cojinete alojamiento	—	6E5-45331-00-94	1	70	Pasador, Clutch	—	90250-08M07-00	1
22	Tornillo, Cojinete alojamiento	—	97395-08025-00	4	71	Retenedor, Pasador	—	6E5-45633-01-00	1
23	Arandela	—	92990-08600-00	4	72	Eje hélice	—	6J9-45611-01-00	1
24	Retén, eje transmisión	18-0265	93101-28M16-00	2	73	Arandela empuje	—	90201-30M92-00	1
25	Tapón, retén aceite	—	6E5-45344-00-00	1	74	Engranaje, Reverso	—	6G5-45571-02-00	1
26	Junta, Platina	18-0244	6E5-44315-A0-00	1	75	Arandela (0.10mm)	—	6G5-45577-02-10	AR
27	Platina	18-3345	6G5-44323-00-00	1		Arandela (0.12mm)	—	6G5-45577-02-12	AR
28	Impulsor	18-3071	6E5-44352-00-00	1		Arandela (0.15mm)	—	6G5-45577-02-15	AR
29	Insertar bomba agua	—	6E5-44322-00-00	1		Arandela (0.18mm)	—	6G5-45577-02-18	AR
30	Aro, bomba agua	18-7485	93210-86M38-00	1		Arandela (0.30mm)	—	6G5-45577-02-30	AR
31	Aro, bomba agua	18-7483	93210-37M67-00	1		Arandela (0.40mm)	—	6G5-45577-02-40	AR
32	Pasador, bomba agua alojamiento	—	93606-12019-00	2		Arandela (0.50mm)	—	6G5-45577-02-50	AR
33	Bomba agua alojamiento	18-3170	6E5-44311-00-00	1	76	Arandela empuje	—	6G5-45576-00-00	1
34	Damper, Retén agua	—	6E5-44365-00-00	1	77	Cojinete, reverso engranaje	—	93306-209U0-00	1
35	Tapón, bomba alojamiento	—	6E5-44312-00-00	1	78	Aro, Cojinete alojamiento	18-0275	93210-97M55-00	1
36	Tornillo, Bomba agua	—	97080-08045-00	4	79	Cojinete	—	6J9-45332-00-94	1
37	Arandela	—	90209-08M02-00	4	80	Llave, cojinete alojamiento	—	90282-04010-00	1
38	Conector	—	6E5-45378-00-00	1	81	Cojinete aguja	—	93315-430U8-00	1
39	Tapón inferior drenaje	18-2374	688-45341-00-00	1	82	Retén, eje hélice	18-0266	93101-30M17-00	2
40	Junta, tapón drenaje	—	90430-08020-00	2	83	Arandela, tapón	—	9G5-45383-01-00	1
41	Tapón drenaje superior	—	90340-08M04-00	1	84	Tuerca, Tapón	—	6G5-45384-00-00	1
42	Junta, tapón drenaje	—	90430-08020-00	2	85	Arandela empuje	—	6E5-45987-00-00	1
43	Pasador	—	93608-12M05-00	2	86	Espaciador, hélice	18-4274	688-45997-01-00	1
44	Tapón, entrada de agua (Babor)	—	6J9-45214-00-00	1	87	Arandela hélice	—	92990-18200-00	1
45	Tapón, entrada de agua (Estr)	—	6J9-45215-00-00	1	88	Tuerca hélice	18-3726	90171-18M04-00	1
46	Tornillo, Entrada de agua	—	90142-05M04-00	1	89	Pasador	18-3735	91490-40030-00	1
47	Tuerca, Entrada de agua	—	90185-05002-00	1	90	Kit retén engranajes alojamiento	18-2794-1	6G5-W0001-21-00	1
48	Tornillo	—	97395-10070-00	1	91	Kit reparación bomba agua	18-3311	6G5-W0078-00-00	1

AR Se requiere

18-0021
KIT RETÉN ALOJAMIENTO ENGRANAJE

Reemplaza: 688-W0001-22-00
Para: C75 (1994-99) / E75 (1995-00) / P75 (1996-99)
C80 (1997) / C85 (1992-96) / 90 (1992-02) B90(1998-99) / C90 (1997-01)

— CONTIENE —

Ref #	Desc.	O.E.#	Cant.
18-0239	Junta	688-44315-A0	1
18-0240	Junta	688-44316-A0	1
18-7436	Aro	93210-46044-00-00	2
18-0267	Retén aceite	93106-09014	1
18-0587	Retén aceite	93101-25M03	4
18-4698	Arandela drenaje	90430-08020	2

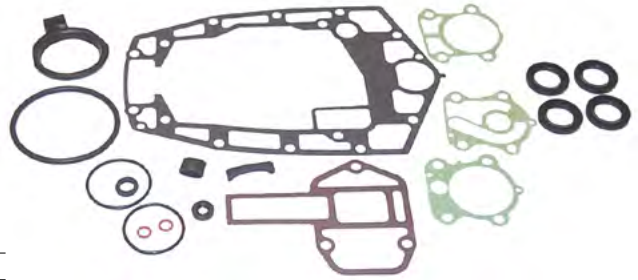

18-0022
KIT RETÉN ALOJAMIENTO ENGRANAJE

Reemplaza: 689-W0001-23-00
Para: C25 (1992-97) / C30 (1992)

— CONTIENE —

Ref #	Desc.	O.E.#	Cant.
18-99010	Junta colector escape	664-41134-A0-00	1
18-0296	Retén, eje hélice	93101-22067	2
18-0554	Retén	93101-20M07	2
18-0773	Junta	689-44316-A0	1
18-4698	Arandela, Drenaje	90430-08020	3

18-0023
KIT RETÉN ALOJAMIENTO ENGRANAJE

Reemplaza: 689-W0001-C2-00
Para: C25 (1986-87) C25 (1990-91) 30 (1986) C30 (1990-91)

— CONTIENE —

Ref #	Desc.	O.E.#	Cant.
18-99010	Junta colector escape	664-41134-A0-00	1
18-0554	Retén	93101-20M07	2
18-4698	Arandela, Drenaje	90430-08020	3

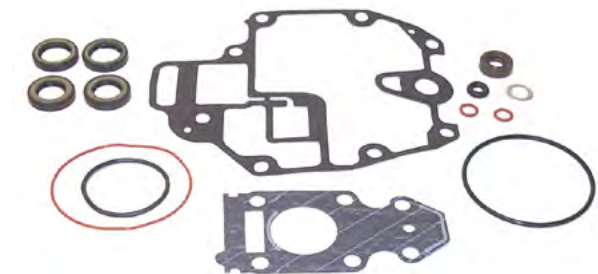

18-0024
KIT RETÉN ALOJAMIENTO ENGRANAJE

Reemplaza: 698-W0001-21-00
Para: E48 (1995-00) / C55 (1989-94)

— CONTIENE —

Ref #	Desc.	O.E.#	Cant.
18-0292	Junta	663-44315-A0	1
18-0294	Junta	663-44324-A0	1
18-0297	Retén, eje transmisión	93101-23070	2
18-0296	Retén, eje hélice	93101-22067	2
18-0298	Aro	93210-41042	1
18-7160	Aro	93210-66M98	1
18-4698	Arandela, Drenaje	90430-08020	3

18-0025
KIT RETÉN ALOJAMIENTO ENGRANAJE

Reemplaza: 69G-W0001-20-00
Para: T8 (2001-04)

— CONTIENE —

Ref #	Desc.	O.E.#	Cant.
18-7442	Aro	93210-74M68	1
18-4698	Arandela, Drenaje	90430-08020	2



18-0026
KIT RETÉN ALOJAMIENTO ENGRANAJE
Reemplaza: 6A1-W0001-22-00
Para: 2HP (1986-88)

— CONTIENE —



18-0027
KIT RETÉN ALOJAMIENTO ENGRANAJE
Reemplaza: 6A1-W0001-23-00
Para: 2HP (1989-02)

— CONTIENE —

Ref #	Desc.	O.E.#	Cant.
18-4698	Arandela, Drenaje	90430-08020	2

Ref #	Desc.	O.E.#	Cant.
18-4698	Arandela, Drenaje	90430-08020	2



18-0028
KIT RETÉN ALOJAMIENTO ENGRANAJE
Reemplaza: 6E0-W0001-C1-00
Para: 4HP (1984-99) / F4 (1999-02) / 5HP (1984-02)

— CONTIENE —



18-0029
KIT RETÉN ALOJAMIENTO ENGRANAJE
Reemplaza: 6G1-W0001-C1-00
Para: 6HP (1986-96) 8HP (1984-96)

— CONTIENE —

Ref #	Desc.	O.E.#	Cant.
18-4698	Arandela, Drenaje	90430-08020	3

Ref #	Desc.	O.E.#	Cant.
18-4698	Arandela, Drenaje	90430-08020	3



18-0030
KIT RETÉN ALOJAMIENTO ENGRANAJE
Reemplaza: 6L2-W0001-C3-00
Para: 20HP (1996-97) 25HP (1988-02) 2 cil

— CONTIENE —



18-0031
KIT RETÉN ALOJAMIENTO ENGRANAJE
Reemplaza: 6N0-W0001-C0-00
Para: 6HP (1997-00), 8HP (1997-04)

— CONTIENE —

Ref #	Desc.	O.E.#	Cant.
18-0554	Retén	93101-20M07	2
18-4698	Arandela, Drenaje	90430-08020	2

Ref #	Desc.	O.E.#	Cant.
18-4698	Arandela, Drenaje	90430-08020	3

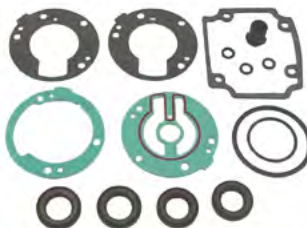

18-2785
KIT RETÉN ALOJAMIENTO ENGRANAJE
Reemplaza: 689-W0001-21-00, 689-W0001-C1-00

— CONTIENE —

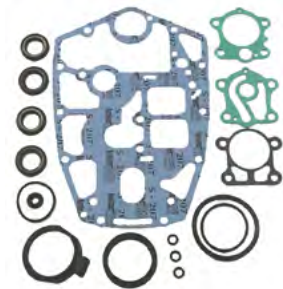

18-2787
KIT RETÉN ALOJAMIENTO ENGRANAJE
Reemplaza: 698-W0001-20-00, 698-W0001-C0-00

— CONTIENE —

Ref #	Desc.	O.E.#	Cant.
18-0776	Casquillo	682-44365-00-00	1
18-0552	Casquillo	689-44366-00-00	1
18-4698	Junta drenaje/llenado	YSG-14090-90-8G	3
18-0554	Retén aceite	93101-20M07-00	1
18-0296	Retén aceite	93101-22067-00	2
18-7405	Aro	93210-40M10-00	1
18-0766	Junta tubo escape	664-41134-A0-00	1
18-0773	Junta platina desgaste	689-44316-A0-00	1

Ref #	Desc.	O.E.#	Cant.
18-4698	Arandela drenaje	YSG-14090-90-8G	3
18-0296	Retén aceite	93101-22067-00	2
18-0297	Retén aceite	93101-23070-00	2
18-0298	Aro	93210-41042-00	1
18-0299	Aro	93210-66M98-00	1
18-0292	Junta platina a alojamiento bomba	663-44315-A0-00	1
18-0267	Aro	93106-09014-00	1
18-0294	Junta platina a base bomba	663-44324-A0-00	1

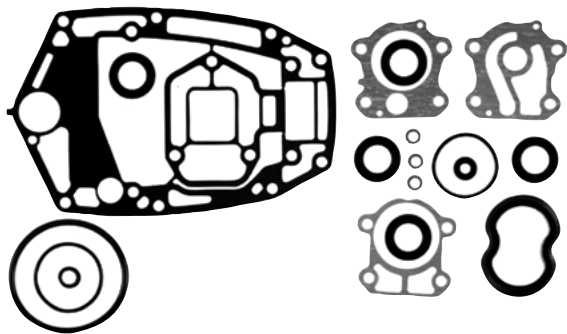

18-2788

KIT RETÉN UNIDAD INFERIOR

Reemplaza: 6H3-W0001-21-00, 6H3-W0001-C1-00

– CONTIENE –

Ref #	Desc.	O.E. #	Cant.
18-0240	Junta platina desgaste	688-44316-A0-00	1
18-0756	Junta bomba agua	6H3-44315-A0-00	1
18-0757	Junta platina	6H3-44324-A0-00	1
18-4698	Arandela llenado/drenaje	YSG-14090-90-8G	3
18-0297	Retén aceite	93101-23070-00	2
18-0267	Retén aceite	93106-09014-00	1
18-7436	Aro	93210-46044-00	1

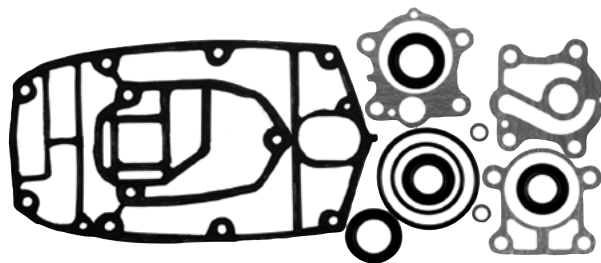

18-2789

KIT RETÉN UNIDAD INFERIOR

Reemplaza: 6J8-W0001-21-00, 6J8-W0001-C2-00

– CONTIENE –

Ref #	Desc.	O.E. #	Cant.
18-0292	Junta platina desgaste	663-44315-A0-00	1
18-0294	Junta platina desgaste	663-44324-A0-00	1
18-4698	Arandela drenaje/llenado	YSG-14090-90-8G	2
18-0554	Retén aceite	93101-20M07-00	2
18-0297	Retén aceite	93101-23070-00	2
18-0298	Aro	93210-41042-00	1

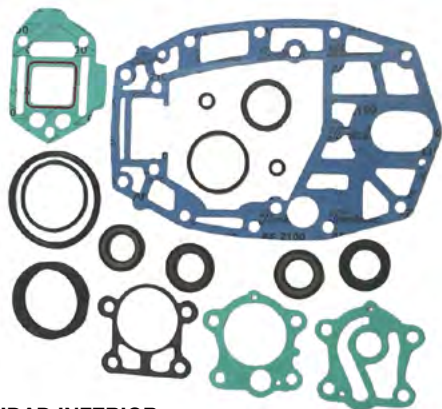

18-2792

KIT RETÉN UNIDAD INFERIOR

Reemplaza: 6H4-W0001-21-00, 6H4-W0001-20-00

– CONTIENE –

Ref #	Desc.	O.E. #	Cant.
18-0292	Junta platina desgaste	663-44315-A0-00	1
18-0294	Junta platina desgaste	663-44324-A0-00	1
18-4698	Junta drenaje / llenado	YSG-14090-90-8G	2
18-0296	Retén aceite	93101-22067-00	2
18-0297	Retén aceite	93101-23070-00	2
18-0298	Aro	93210-41042-00	1
18-0299	Aro	93210-66M98-00	1
18-0293	Junta base bomba	663-44316-A0-00	1

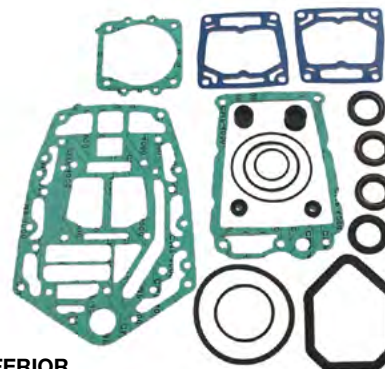

18-2794-1

KIT RETÉN UNIDAD INFERIOR

Reemplaza: 6F3-W0001-21-00, 6F3-W0001-C1-00

6E5-W0001-51-00, 6E5-W0001-F1-00

6G5-W0001-21-00, 6G5-W0001-C1-00

– CONTIENE –

Ref #	Desc.	O.E. #	Cant.
18-0244	Junta bomba agua	6E5-44315-A0-00	1
18-4698	Junta drenaje/llenado	YSG-14090-90-8G	2
18-0265	Retén aceite	93101-28M16-00	2
18-0266	Retén aceite	93101-30M17-00	2
18-0267	Retén aceite	93106-09014-00	1
18-7483	Aro	93210-37M67-00	1
18-7485	Aro	93210-86M38-00	1
18-0275	Aro	93210-97M55-00	1

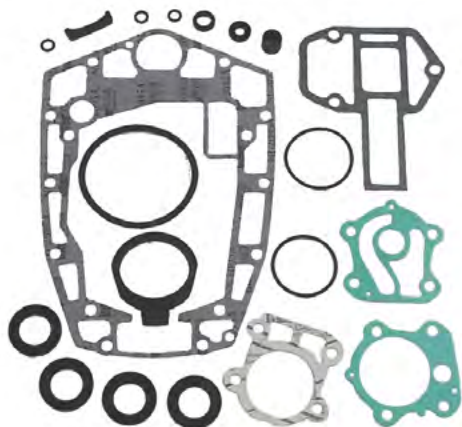

18-2798

KIT RETÉN INFERIOR

Reemplaza: 688-W0001-20-00, 688-W0001-C0-00

– CONTIENE –

Ref #	Desc.	O.E. #	Cant.
18-0240	Junta	688-44316-A0-00	1
18-4698	Junta drenaje llenado	YSG-14040-90-8G	3
18-7436	Aro	93210-46044-00	1
18-0239	Junta platina aloj. bomba	688-44315-A0-00	1
18-0267	Retén aceite	93106-09014-00	1

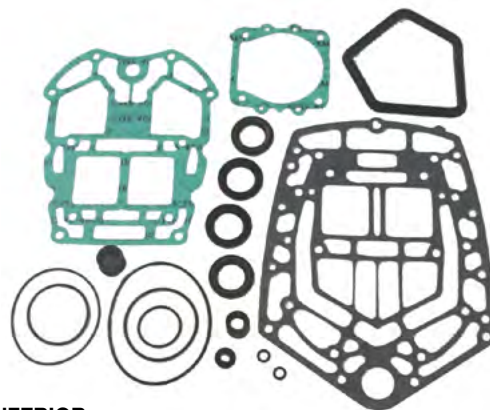

18-2799

KIT RETÉN INFERIOR

Reemplaza: 61A-W0001-21-00, 61A-W0001-C1-00

– CONTIENE –

Ref #	Desc.	O.E. #	Cant.
18-0244	Junta bomba agua	6E5-44315-A0-00	1
18-4698	Junta drenaje/llenado	YSG-14040-90-8G	2
18-0265	Retén aceite	93101-28M16-00	2
18-0266	Retén aceite	93101-30M17-00	1
18-0267	Retén aceite	93106-09014-00	1
18-7483	Aro	93210-37M67-00	1
18-7485	Aro	93210-86M38-00	1
18-7444	Aro	93210-04384-00	1

APLICACIÓN KIT RETÉN ALOJAMIENTO ENGRANAJES

Modelo #	Año	kit juntas unidad inf.	Modelo #	Año	Kit juntas unidad inf.	Modelo #	Año	kit juntas unidad inf.
2	1986-88	18-0026	C55	1992-95	18-0024	SX150	1999-04	18-2794-1
2	1989-02	18-0027	CV55	1989-90	18-2787	V150	2000-08	18-2794-1
4	1984-99	18-0028	P60	1991	18-2788	VX150	2000-04	18-2794-1
F4	1999-08	18-0028	70	1984-85, 1988-91	18-2788	VZ150	2000-11	18-2794-1
5	1984-02	18-0028	C75	1994-99	18-0021	175	1984-00	18-2794-1
6	1988-96	18-0029	E75	1995-00	18-0021	P175	1994-99	18-2794-1
6	1997-00	18-0031	P75	1996-99	18-0021	S175	1996-99	18-2794-1
8	1984-96	18-0029	C80	1997	18-0021	V175	2000	18-2794-1
8	1997-09	18-0031	C85	1991	18-2798	VZ175	2001-11	18-2794-1
T8	2001-10	18-0025	C85	1992-96	18-0021	Z175	2001-05	18-2794-1
20	1996-97	18-0030	CV85	1989-90	18-2798	200	1984-98	18-2794-1
25 ①	1984-85	18-2785	90	1984-91	18-2798	L200	1986-99	18-2794-1
25 ①	1986-87	18-0023	90	1992-09	18-0021	LX200	1999-01	18-2794-1
25 ①	1988-09	18-0030	B90	1997-99	18-0021	LZ200	2000-11	18-2794-1
25 ②	1997-02	18-2789	C90	1997-	18-0021	P200	1991-99	18-2794-1
C25	1991	18-0023	115	1986-09	18-2794-1	S200	1996-99	18-2794-1
C25 ①	1992-97	18-0022	C115	1992-00	18-2794-1	SX200	1999-05	18-2794-1
CV25	1990	18-0023	P115	1993-96	18-2794-1	VZ200	2001-04	18-2794-1
T25 ①	2002	18-0020	S115	1996-99	18-2794-1	Z200	2000-11	18-2794-1
30	1984-85	18-2785	130	1988-04	18-2794-1	V6 Especial	1984-86	18-2794-1
30	1986	18-0023	L130	1989-01	18-2794-1	V6 Excel	1987-89	18-2794-1
30	1987-02	18-2789	S130	1996-99	18-2794-1	225 ③	1990-97	18-2794-1
C30	1991	18-0023	150	1984-09	18-2794-1	225 ④	1994-96	18-2799
C30	1992	18-0022	C150	1996-99	18-2794-1	L225 ④	1994-96	18-2799
F30 ②	2002	18-0020	L150	1986-99	18-2794-1	S225	1996	18-2799
40	1984-94	18-2792	LX150	1999-01	18-2794-1	250	1990-95	18-2799
C40	1992-94	18-99104	LZ150	2000-05	18-2794-1	L250	1990-96	18-2799
F40 ②	2002	18-0020	Z150	2000-05	18-2794-1	S250	1996	18-2799
50	1986-94	18-2792	P150	1991-99	18-2794-1			
PRO 50	1987-90	18-2792	PX150	1999	18-2794-1			
P50	1992-94	18-2792	PRO V150	1987-90	18-2794-1			
C55	1991	18-2787	S150	1996-99	18-2794-1			

- ① 2 cilindro modelo ② 3 cilindro modelo ④ 3.1 litros
 ③ 2.6 litros

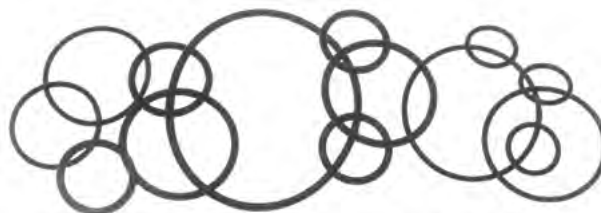

RETÉN ACEITE



Ref #	O.E#	Dimensiones		
		D.I.	D.E.	Ancho
18-0265	93101-28M16-00	27	43.25	7
18-0266	93101-30M17-00	28.5	45.25	7
18-0267	93106-09014-00	8.75	19.2	5.25
18-0296	93101-22067-00	23	36.25	6
18-0297	93101-23070-00	22.75	37.25	6
18-0554	93101-20M07-00	21.5	34	6.25
18-0570	93102-23096-00	22.75	38.25	7
18-0587	93101-25M03-00	24	40.25	6
18-2079	93101-22M15-00	21.75	35.2	6
18-0588	93102-35M13-00	34	52.25	8
18-2085	93102-25M28-00	24.5	48.4	8
18-2087	93102-40M36-00	39.5	58.25	8.5
18-2091	93102-22M07-00	22	29.25	5

AROS

Ref #	Est. Pkg.	O.E.#	Ref #	Est. Pkg.	O.E.#
18-0275	1	93210-97M55-00	18-7469	1	64E-43869-00-00
18-0298	1	93210-41042-00	18-7470	1	65W-43865-00-00
18-0299	1	93210-66M98-00	18-7483	1	93210-37M67-00
18-7119	1	93210-33M85-00	18-7485	1	93210-86M38-00
18-7432 ⑤	2	93210-32738-00	18-76689	1	65W-14198-00-00
18-7436	1	93210-46044-00	18-76690	1	93210-46M16-00
18-7442	1	93210-74M35-00	18-76691	1	93210-27ME3-00
18-7444	1	93211-04384-00	18-76692	1	93210-75M51-00
18-7463	1	93210-19123-00	18-76693	1	93210-31MJ5-00
18-7468	1	6G5-43864-00-00	18-76694	1	93210-24M79

⑤ Precio por pieza. Pedir precio por pack, añadir -9 a la referencia.

POTENCIA HP	AÑO	Ref. CHAMPION	Ref. PRONAUTIC	POTENCIA HP	AÑO	Ref. CHAMPION	Ref. PRONAUTIC
2	1984+	L90C	051028	30F	2001+	RA8HC	050957
3	1988+	QL86C/L86C	050919/050910	40F	1999+	RA8HS	051015
5	1984+	QL82C/L82C	050966/050937	50F	1999+	RA8HC	050957
6	1986+	QL82C/L82C	050966/050937	60	2002+	RA8HC	050957
8	1984+	QL82C/L82C	050966/050937	75	2003+	10YC4	050984
9,9	1984+	QL82C/L82C	050966/050937	80	1999+	10YC4	050984
20	1996+	QL82C/L82C	050966/050937	90B	1984+	QL78C/L78C	050915/050907
25	1999+	QL82C/L82C	050966/050937				
30	1984+	QL82C/L82C	050966/050937				
40	1984+	QL82C/L82C	050966/050937				
50	1995+	RA8HC	050957				
70	1984+	QL78C/L78C	050915/050907				
90	1984-2000	QL78C/L78C	050915/050907				
115	1984-2005	QL78C/L78C	050915/050907				
130	1989+	QL78C/L78C	050915/050907				
150 Carb	1996+	QL82C/L82C	050966/050937				
150EFI	1999-2000	QL78C/L78C	050915/050907				
150EFI	2000+	RC12YC	051012				
150MPDI	2000+	RC12YC	051012				
150VMAX	1997+	QL78C/L78C	050915/050907				
175	1984+	QL78C/L78C	050915/050907				
175VMAX	1992+	QL78C/L78C	050915/050907				
200LX	1999+	QL78C/L78C	050915/050907				
200LZ	1999+	RC9YC4	051013				
200SX	1999+	QL78C/L78C	050915/050907				
200VX	2000+	QL78C/L78C	050915/050907				
200Z	2000+	RC9YC4	051013				
225	2000+	QL77JC4/ L77JC4	050914/050906				
250	2000+	QL77JC4/ L77JC4	050914/050906				
4 TIEMPOS							
2.5F	2003+	QL86C/L86C	050919/050910				
4F	1999+	QL86C/L86C	050919/050910				
9.9Fi	1996+	Z9Y	051014				
9.9T	1996+	Z9Y	051014				
15F	1999+	RA8HS	051015				
25F	1998+	RA8HS	051015				

YAMAHA 				YAMAHA 			
POTENCIA HP	AÑO	Ref. CHAMPION	Ref. PRONAUTIC	POTENCIA HP	AÑO	Ref. CHAMPION	Ref. PRONAUTIC
2A		B6HS	050804	20C(C20)	99-	B7HS	050806
2B	87-	BR5HS	050892	20C/CE/CM		BR7HS-10	050832
2B	85-86	B7HS	050806	20D		BR7HS-10	050832
2B	-84	BR5HS	050892	25A		B7HS	050806
2C	95-	B7HS	050806	25B	-94	B7HS	050806
3.5A/AC		B6HS	050804	25B	01-	BR7HS-10	050832
3A (Malta)		BR6HS-10	050880	25B/25Q	95-00	BR7HS-10	050832
4A/AC/AS/BC		BR7HS	050853	25CMK		B6HS	050804
4A/B	01-	B7HS	050806	25D (25)		B7HS	050806
5A/AS		B7HS	050806	25DE		BR7HS-10	050832
5B/BS		B6HS	050804	25J		BR7HS-10	050832
5C		BR7HS	050853	25N		BR7HS-10	050832
5D		B5HS	050802	25V (25)	95-	BR7HS-10	050832
6A		B6HS	050804	28A/AE		B7HS	050806
6B		B5HS	050802	30A/AE/AM		B7HS	050806
6C		BR7HS-10	050832	30D		BR7HS-10	050832
6D		BR6HS-10	050880	30G	95-	B8HS-10	050810
7A		B6HS	050804	30H	01-	B8HS-10	050810
8A		B6HS	050804	40AE/AM/AR		B8HS	050809
8B		B7HS	050806	40BE/BM/BR		B8HS	050809
8C		BR7HS-10	050832	40C		B8HS	050809
9.5A		B7HS	050806	40D	-89	B8HS	050809
9.9B		B7HS	050806	40F		B8HS	050809
9.9D		BR7HS-10	050832	40FE		B7HS-10	050807
9.9F	95-	BR7HS-10	050832	40GK		B7HS	050806
9A		B6HS	050804	40H		BR7HS-10	050832
12A		B7HS	050806	40J	01-	B7HS	050806
13.5A		BR7HS-10	050832	40Q(40)	95-	BR8HS	050854
13.5F		B7HS-10	050807	40V	95-	BR7HS-10	050832
15A		B7HS	050806	40X	-00	BR7HS	050853
15B		B7HS	050806	40Y (ET)	01-	BR8HS-10	050835
15C		B7HS	050806	40Y (MH)	01-	BR7HS-10	050832
15D		BR7HS-10	050832	48A/B		B7HS	050806
15F	95-	BR7HS-10	050832	50	01-	B8HS-10	050810
20A		B6HS	050804	50C		B8HS	050809
20B		B6HS	050804	50CE		B8HS-10	050810

YAMAHA**YAMAHA**







POTENCIA HP	AÑO	Ref. CHAMPION	Ref. PRONAUTIC	POTENCIA HP	AÑO	Ref. CHAMPION	Ref. PRONAUTIC
50D		BR8HS-10	050835	130BETO		BR9HS-10	050837
50G/50H	95-	BR8HS-10	050835	140A		BR8HS-10	050835
60TLRB	03-	B7HS-10	050807	140B	-88	BR8HS-10	050835
55AE	-78	B8HS	050809	140B	89-	BR9HS-10	050837
55AE	79-	B8HS-10	050810	140BETO		BR9HS-10	050837
55AEM/AM/AW		B8HS	050809	140C/L140C	95-	BR9HS-10	050837
55B		B8HS-10	050810	150A	86-	BR8HS-10	050835
55B	90-	BR8HS-10	050835	150A	-85	BR7HS-10	050832
55B(M)	95-	B8HS	050809	150AETO/C		BR8HS-10	050835
55BM/BW		B8HS	050809	150C		BR8HS-10	050835
60	01-	B8HS-10	050810	150F/L150F		BR7HS-10	050832
60AE	-78	B8HS	050809	150G		BR7HS-10	050832
60AE	79-	B8HS-10	050810	175A		BR8HS-10	050835
60B		B8HS-10	050810	175B		BR8HS-10	050835
60CE/CET		B8HS-10	050810	175D		BR8HS-10	050835
60D	86-	BR8HS-10	050835	175F		BR8HS-10	050835
60DE		B8HS-10	050810	200A		BR8HS-10	050835
60F		BR8HS-10	050835	200C		BR9HS-10	050837
70B		BR8HS-10	050835	200F(L200F)		BR8HS-10	050835
70C		BR8HS-10	050835	200G		BR8HS-10	050835
70ETO		BR8HS-10	050835	220A/AET	86-	BR8HS-10	050835
75A		BR8HS-10	050835	225AETO		BR8HS-10	050835
75B		BR8HS-10	050835	225AO/BETO/B/C		BR9HS-10	050837
75C		BR8HS-10	050835	225D		BR8HS-10	050835
80A		BR8HS-10	050835	225G		BR9HS-10	050837
85A		BR8HS-10	050835	250A/L250A		BR8HS-10	050835
90A		BR8HS-10	050835	250B/L250B		BR9HS-10	050837
100AETOL	98-	BR8HS-10	050835	50H	95-	BR8HS-10	050835
100A		BR8HS-10	050835	D150H		BR8HS-10	050835
115A	04-	B8HS-10	050810	E8D		BR7HS-10	050832
115AEO/AO		BR8HS-10	050835	E40X/40X		BR7HS	050853
115B/BETO		BR8HS-10	050835	E60H		BR8HS-10	050835
115C		BR8HS-10	050835	4 TIEMPOS			
115D	95-	BR8HS-10	050835	F2.5A	02-	BR6HS	050714
130A		BR9HS-10	050837	F4A	98-	BR6HS	050714
130B	95-	BR9HS-10	050837	F6A	00-	BR6HS-10	050880









Bujías
YAMAHA

YAMAHA**YAMAHA**

POTENCIA HP	AÑO	Ref. CHAMPION	Ref. PRONAUTIC	POTENCIA HP	AÑO	Ref. CHAMPION	Ref. PRONAUTIC
F6B	01-	BR6HS-10	050880	L150/A/C/D	95-	BR8HS-10	050835
F8	01-	BR6HS-10	050880	L150AETO/CETO		BR8HS-10	050835
F8-A	85-	CR6HS	050845	L150F		BR7HS-10	050832
F8B/AM-AEM	86-02	CR5HS	050883	L200A/B	95-	BR8HS-10	050835
F8B/BM/BE	86-	CR5HS	050883	L200AETO/BETO		BR8HS-10	050835
F8C	00-	BR6HS-10	050880	L200F		BR8HS-10	050835
F9.9DE		BR7HS-10	050832				
F9.9A	85-00	CR6HS	050845				
F9.9B	86-00	CR6HS	050845				
F9.9C/D	98-03	DPR6EA-9	050865				
F13.5A	98-03	DPR6EA-9	050865				
F15A	98-03	DPR6EA-9	050865				
F20A	98-01	DPR6EA-9	050865				
F25A (E, ET)	98-02	DPR6EA-9	050865				
F25A (MH)		DPR6EA-9	050865				
F30A	01-02	DPR6EA-9	050865				
F30 OHC	01-02	DPR6EA-9	050865				
F40A/B	00-02	DPR6EA-9	050865				
F40C		DPR5EA-9	050896				
F45A/AETL	98-	DPR6EA-9	050865				
F50A/B	95-02	DPR6EA-9	050865				
F60A	02-	DPR5EA-9	050896				
F80A	00-03	LFR5A-11	050862				
F100A	99-03	LFR5A-11	050862				
F115V-41 7L	99-03	LFR6A-11	050881				
F115A (FL-115A)		LFR6A-11	050881				
F150A (FL-150A)		LFR5A-11	050862				
FT8D		BR6HS-10	050880				
FT9.9A	98-	CR6HS	050845				
FT9.9D		DPR6EA-9	050865				
FT25B		DPR6EA-9	050865				
FT50B/BETL	98-	DPR6EA-9	050865				
FT50C/G		DPR6EA-9	050865				
FT60B/D		DPR5EA-9	050896				
FX700(FX-1)	95-	BR8HS	050854				
L140 BETO		BR9HS-10	050837				

YAMAHA

Tipo	Modelo Fueraborda	Descripción	Ref. Original	Pala	Mark	Remarks	
Y5		4 - 6 hp	62Y57127	6E0-45943-01-EL	3	BA	Fijo
		<ul style="list-style-type: none"> • 4hp (2 tiempos) 1986-1999 • F4hp (4 tiempos) 1999 y posteriores • 5hp (2 tiempos) 1995-2002 • F6Ahp (4 tiempos, 1cil.) 2011 y post. 	7 1/2x7				
		Escape no a través del núcleo, 9 estrías	62Y57128	6E0-45941-01-EL	3	BA	
			7 1/2x8				
Y8		6 - 9.9 hp	62Y812812	6G1-45941-00-00	3	N	Fijo
		<ul style="list-style-type: none"> • 6hp (2 tiempos) 1986-2000 • F6hp (4 tiempos) 2001-2010 • 8hp (2 tiempos) 1986-2009 • F8hp (4 tiempos) 2001 y posteriores • F9.9hp (4 tiempos) 2008 y posteriores 	8 1/2x8 1/2				
		Escape a través del núcleo, 7 estrías	62Y812914	6G1-45954-00-00	3	N	
			8 1/2x9 1/4				
A		9.9 - 20 hp 2-1/2" Caja de engranajes	62Y159148 9 1/4x8	683-45947-00-EL	3	J	Fijo
		<ul style="list-style-type: none"> • 9.9hp (2 tiempos) 1984-2009 • F9.9hp (4 tiempos) 2000-2007 • 15hp (2 tiempos) 1984-2009 • F15hp (4 tiempos) 1998 y posteriores • F15C 2007 y posteriores • F20hp (4 tiempos) 2007 y posteriores 	62Y159149 9 1/4x9	683-45945-00-EL	3	J	
			62Y15914934 9 1/4x9 3/4	683-45952-00-EL	3	J	
			62Y159141012 9 1/4x10 1/2	683-45943-00-EL	3	J	
			62Y1591411 9 1/4x11	63V-45943-10-00	3	J1	
			62Y1591412 9 1/4x12	63V-45941-10-EL	3	J	
Escape a través del núcleo, 8 estrías							
B		20 - 30 hp 3" Caja de engranajes	62Y309789 9 7/8x9	664-45941-01-EL	3	F	Fijo
		<ul style="list-style-type: none"> • 20hp 1996-1997 • 25hp 1980 y posteriores • F25hp (4 tiempos) 1998-2006 2010 y posteriores • 30hp 1983 - 2002 	62Y309781012 9 7/8x10 1/2	664-45945-00-EL	3	F	
			62Y309781114 9 7/8x11 1/4	664-45947-01-EL	3	F	
			62Y3097812 9 7/8x12	664-45954-01-EL	3	F	
			62Y3097813 9 7/8x13	664-45949-02-EL	3	F	
			62Y3097814 9 7/8x14	664-45952-00-EL	3	F	
Escape a través del núcleo, 10 estrías							
C	  	25 - 60 hp 3-1/2" Caja de engranajes	62Y4012149 12 1/4x9	663-45956-01-EL	3	G	Fijo
		<ul style="list-style-type: none"> • T25hp 2010 y posteriores • F30hp (4 tiempos) 2001-2005 2015 y posteriores • 40hp (includos C40) 1984 y posteriores • F40hp (4 tiempos) 1999 y posteriores • 48hp 1995 y 2000 • 50hp (no T50) 1984 y posteriores • F50hp (4 tiempos) 1995 y posteriores • 55hp 1976-1995 • 60hp 1976-1991 • F60hp (4 tiempos) 1999 y posteriores 	62Y40113410 11 3/4x10	663-45954-01-EL	3	G	
			62Y40115811 11 5/8x11	663-45947-02-EL	3	G	
			62Y40105812 10 5/8x12	6H5-45952-00-EL	3	G	
			62Y40113812 11 3/8x12	663-45952-02-EL	3	G	
			62Y40103813 10 3/8x13	6H5-45945-00-EL	3	G	
			62Y40111813 11 1/8x13	663-45945-02-EL	3	G	
			62Y40101414 10 1/4x14	6H5-45958-00-EL	3	G	
			62Y40111414 11 1/4x14	663-45958-01-EL	3	G	
			62Y401115 11x15	69W-45943-00-EL	3	G	
			62U4012149 12 1/4x9		3		
			62U40113410 11 3/4x10		3		
			62U40115811 11 5/8x11		3		
			62U40113812 11 3/8x12		3		
			62U40111813 11 1/8x13		3		
			62U40111414 11 1/4x14		3		
			624U40105812 10 5/8x12	48-8M8026625	4		
			624U40103813 10 3/8x13	48-8M8026630	4		
624U40101814 10 1/8x14	48-8M8026635	4					
624U40101815 10 1/8x15	48-8M8026640	4					
Escape a través del núcleo, 13 estrías					Interc. 62BHYC		

Tipo	Modelo fueraborda	Referencia-Diam./Paso	Ref. Original	Pala	Mark	Núcleo		
A	 <p>8 – 9,9 hp 2-1/2" Caja de engranajes • T8, T9.9 Empuje doble, 8 estrías</p>	Y15D 11 3/4x7	69G-45943-00-EL	3	R	Fijo		
C	 <p>40 hp Pasador Colas • E40G, EK40G</p>	PY40 11 3/4x10	676-45945-62-EL	3	H	Fijo Tipo Chaveta		
		PY40 11 1/2x11	676-45941-62-EL	3	H			
D	   <p>50 - 130 hp 4-1/4" Caja de engranajes</p> <ul style="list-style-type: none"> • T50hp 1996 y posteriores • T60hp 2003 y posteriores • 60hp 1992 - 2005 (incluidos C60, E60, P60) • 70hp 1984 y posteriores • F70hp (4 tiempos) 2010 y posteriores • 75hp 1994 – 1999 (incluidos C75, E75, P75) • 75hp (4 tiempos) 2003 y posteriores • 80hp 1997 • F80hp (4 tiempos) 1999 - 2002 • 85hp 1991-1997 • 90hp 1984 y posteriores (incluidos C90) • F90hp (4 tiempos) 1999 y posteriores • F100hp (4 tiempos) 2000 y post. • 115hp 1984 y posteriores (incluidos C115, P115) • F115hp (4 tiempos) 2000 y post. • 130hp 1984 y posteriores <p>Escape a través del núcleo, 15 estrías</p>	62Y60135813 13 5/8x13	6E5-45949-00-EL	3	K	Fijo		
		62Y60131215 13 1/2x15	6E5-45947-00-EL	3	K			
		62Y85131417 13 1/4x17	6E5-45945-01-EL	3	K			
		62Y851319 13x19	6E5-45941-00-EL	3	K			
		62Y85125821 12 5/8x21	6E5-45943-00-EL	3	K			
				62U601410 14x10	48-854342A45	3		Interc. 62BHYD o 62BHYE
				62U901411 14x11	48-77338A45	3		
				62U901413 14x13	48-77340A45	3		
				62U60133415 13 3/4x15	48-77342A45	3		
				62U90131417 13 1/4x17	48-77344A45	3		
				62U901319 13x19	48-77346A45	3		
				62U90123421 12 3/4x21	48-77348A45	3		
				62U90137811 13 7/8x11	8M8026560	4		
				62U90137813 13 7/8x13	8M8026570	4		
				62U90133815 13 3/8x15	8M8026580	4		
		62U901317 13x17	8M8026590	4				
		62U90121219 12 1/2x19	8M8026600	4				
		** Usar núcleo intercambiable 62BHYD en los mot 50-100hp ** Usar núcleo intercambiable 62BHYE en los mot. 115-130 hp						
E	   <p>150 - 300 hp 4-3/4" Caja de engranajes</p> <ul style="list-style-type: none"> • 150hp 1986 y posteriores • F150hp (4 tiempos) 2004 y post. • 175hp 1984 y posteriores • F175hp (4 tiempos) 2014 y post. • 200hp 1984 y posteriores • 200hp (VMAX) 2001 • F200hp (4 tiempos) 2002 y post. • VF200 V MAX SHO 2010 y post. • 220hp (Special) 1984-1985 • 225hp (Excel) 1987-1988 • 225hp 1986 y posteriores • F225hp (4 tiempos) 2002 y post. • VF225 V MAX SHO 2010 y post. • F225 Offshore 2010 y posteriores • 250hp 1990 y posteriores • 250hp (VMAX) 2001 • F250 (4 tiempos) 2002 y posteriores • VF250 V MAX SHO 2010 y post. • F250 offshore 2010 y posteriores <p>Escape a través del núcleo, 15 estrías</p>	62Y150151415 15 1/4x15	6G5-45941-01-98	3	M	Fijo		
		62Y150141217 14 1/2x17	6G5-45947-01-98	3	M			
		62Y1501419 14x19	6G5-45945-01-98	3	M			
		62Y150133421 13 3/4x21	6G5-45943-01-98	3	M			
		62Y150131223 13 1/2x23	6G5-45949-00-98	3	M			
				62U1501613 16x13	48-78114A45	3		Interc. 62BHYE
				62U150151415 15 1/4x15	48-78116A45	3		
				62U1501616 16x16	48-16440A45	3		
				62U1351517 15x17	48-832828A45	3		
				62U150141219 14 1/2x19	48-832830A45	3		
				62U150141421 14 1/4x21	48-832832A45	3		
				62U1501423 14x23	48-832834A45	3		
				624U1501516 15x16	48-834850A45	4		
				624U150141218 14 1/2x18	48-834852A45	4		
				624U1501420 14x20	48-834854A45	4		
		**No utilizar 150-300hp 4 tiempos y SHO						

Identificación de modelo

Descripción modelo	HP	Modelo de variación de Longitud	Año del Eje	Modelo
DT = 2-ciclos DF = 4-ciclos PU = Jet Drive	Ejemplos: 9.9 40 115 250	E - Arranque eléctrico mando popa R - Arranque eléctrico control remoto C - Inyección aceite G - Contra rotación N - Hélice alto empuje T - Power Tilt & Trim con arranque eléct. y control remoto H - Power Tilt & Trim con arranque eléct. y mando popero SF - Super 4 SS - Super 6 M - Arranque manual con mando popero V - Alarma voz	S = 15" L = 20" X = 25"	D = 1983 E = 1984 F = 1985 G = 1986 H = 1987 J = 1988 K = 1989 L = 1990 M = 1991 N = 1992 P = 1993 R = 1994 S = 1995 T = 1996 V = 1997 W = 1998 X = 1999 Y = 2000 K1 = 2001 K2 = 2002 K3 = 2003 K4 = 2004 K5 = 2005 K6 = 2006 K7 = 2007 K8 = 2008

Ejemplo: DT40CRSN - 2-ciclo, 40 HP, Inyección aceite, Arranque eléctrico con control remoto, 15", Año1992

<p>Pack. de 10</p>  <p>18-5224 18-5224-9 ① CABLE TERMINAL ENCENDIDO</p>	 <p>18-5225 KIT CABLE BUJÍAS Kit incluye 25 pies. de cable de 7 MM Hypalon con cable encendido alma metálica y un largo surtido de 3 terminales diferentes para motores fueraborda.</p>	 <p>18-5226 CABLE ENCENDIDO Núcleo metálico Bobina 100' 7mm Hypalon</p>
<p>Pack. de 10</p>  <p>18-5750 18-5750-9 ① TAPA BUJÍAS UNIVERSAL Suministrado completo con conector termial</p>	 <p>18-5752 TAPA BUJÍAS UNIVERSAL 8mm</p>	 <p>18-5151 BOBINA DE ENCENDIDO Reemplaza: 33410-94400, 33410-92L10 Para: DT40C(1986-98)</p>
 <p>18-5152 BOBINA DE ENCENDIDO Reemplaza: 32140-93900 Para: DT 9.9(1983-87), DT15 (1983-88)</p>	 <p>18-5144 CDI Reemplaza: 32900-93911 Para: DT15</p>	 <p>MP51010 (CLAMSHELL) MP51012 (CAJA 100 PCS/CTN) INTERRUPTOR ENCENDIDO Reemplaza: 37110-99E00 Colores de los cables iguales que los de fabrica Suzuki 2 & 4 tiempos fueraborda</p>

① Precio por envase

Encendido
SUZUKI

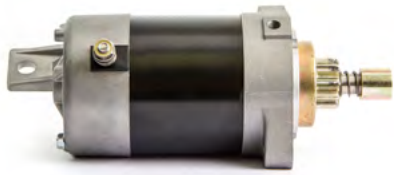

18-6414
ARRANQUE FUERABORDA
 Reemplaza: 31100-95600
 Para: 75 HP



18-6416
ARRANQUE FUERABORDA
 Reemplaza: 31100-94610
 Para: 115, 140 H.P. (9 dientes) (1984-SUP)



18-6417
ARRANQUE FUERABORDA
 Reemplaza: 31100-92E00
 Para: 150, 200, 225 H.P. (1985-SUP)



18-6419
ARRANQUE FUERABORDA
 Reemplaza: 31100-89J00
 Para: 4 tiempos DF40 (1999-01) (9 dientes)



18-6827
MOTOR ARRANQUE
 Reemplaza: 31100-94600, 31100-94601,
 31100-94610
 Para: motor 115, 140HP



18-6428
MOTOR ARRANQUE
 Reemplaza: 31100-95313. Para:
 50/60HP (1984-85), 75/85HP (1984-87).



18-6429
ARRANQUE FUERABORDA
 Reemplaza: 31100-94702
 Para: DT 55/65 (1985-88)



18-6831
MOTOR ARRANQUE
 Reemplaza: Suzuki 31100-90J00
 Hitachi S114-837, A
 Para: Suzuki 90-115HP 2001-08



18-6941
MOTOR ARRANQUE
 Reemplaza: 31100-93J00, 96J00, 96J01
 Para: 70-300HP 2004-sup



18-6945
MOTOR ARRANQUE
 Reemplaza: 31100-95J00, 95J01
 Para: Johnson, Suzuki 25HP 2006-11



18-56009
ESCOBILLA
 Reemplaza: 31173-99E00
 Para: 115-140 HP 2 tiempos
 Use con motor arranque 18-6416



18-9802
LUZ CRONOMETRAJE
 Hasta 10,000 RPM's



18-18303

MOTOR POWER TRIM

Reemplaza: 38100-92J02, 38100-92J10, 38100-93J01, 38100-93J02, 38100-96J00
(Aro incluido)
Para: DF60-300(2001-07)



18-18304

MOTOR POWER TRIM

Reemplaza: 37100-87J00-0EP, 38100-87J0EP
(Aro incluido)
Para: DF40(1999-00), DF50(1999-00)



18-6793

MOTOR TRIM

Reemplaza: 38100-87J11, 38100-87J20
(Aro incluido)
Para: DF40, DF50 (2001-08)



18-6785

MOTOR TILT/TRIM

Reemplaza: 38100-87E10-0ED,
38100-87000-0IT, 38100-87E20-0ED
(Aro incluido)
Para: V-4 & V-6 1986-1990
V-6/3 cables 3 tornillos



18-6786-1

MOTOR TILT/TRIM

Reemplaza: 38100-87D10-0ED,
38100-87D10-35J, 38100-87D10-0IT,
38100-92E00-0ED
Para: V4 & V6 (1990-sup), DT90 (1991-97), DT100
& DT200 (1991-2000), DT150 & DT225 (1991-2003),
DT175 (1991-92)
3 Tornillos 2 cable



18-6837

MOTOR TRIM

Reemplaza: 38100-87J11, 38100-87J20
Para: Motor 40-50HP 4-tiempos



18-6823

CABLEADO

Reemplaza: Universal
Convierte de 3-cables a 2 cables



18-5731

RELÉ, MOTOR ARRANQUE

Reemplaza: 38860-76F01
Para: DF9.9 2005-2010, DF15 2005-2010, DF25 2006-2010,
DF40 2003-2010, DF50 2003-2010, DF60 2003-2010, DF70
2003-2010, DF80 2009-2010, DF90 2003-2010, DF100
2009-2010, DF115 2003-2010, DF140 2003-2010, DF150
2006-2010, DF175 2006-2010, DF200 2004-2010, DF225
2004-2010, DF250 2004-2010, DF300 2007-2010

4-TIEMPOS KIT SISTEMA COMBUSTIBLE



18-7761

KIT RECUPERACIÓN CARBURADOR

Para: Suzuki DF4-DF6 (2005 & Sup)



18-7773

KIT CARBURADOR

Reemplaza: 13910-89J01
Para: DF 25/30 (Todos los años)



18-3495

KIT DIAFRAGMA

Reemplaza: 15170-93911
Para: DT8(todos 1988-97), DT9.9(todos
1988-97), DT15(todos 1988-97)



18-3496

KIT DIAFRAGMA

Reemplaza: 15170-94320
Para: DT25 (todos 1989-99), DT30
(Todos 1989-99), DT40(Todos 1986-98),
DT55(Todos 1988-97), DT65(Todos
1988-97)



18-3497

KIT DIAFRAGMA

Reemplaza: 15170-91J00
DF4-DF6 (2003 & SUP)



18-3498

KIT DIAFRAGMA

Reemplaza: 15170-94J00, 15170-94J0V
DF9.9-DF15 HP(2005 & SUP)



18-3499

KIT DIAFRAGMA

Reemplaza: 15170-99E00
DF9.9,DF15 (1997-2004), DF25 (2000-2006)
(No-V doble), DF40,DF50 (1999-2006),
DF60,DF70 (1998-2007),

2-TIEMPOS KITS SISTEMA COMBUSTIBLE

18-7752
KIT CARBURADOR
Reemplaza: 13910-87D00

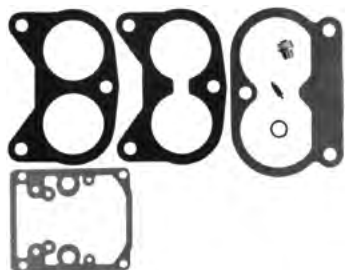

18-7753
KIT CARBURADOR
Reemplaza: 13910-94400



18-7754
KIT CARBURADOR
Reemplaza: 13910-94701



18-7755
KIT CARBURADOR
Reemplaza: 13910-95D00



APLICACIÓN KIT CARBURADOR

HP/Modelo	Año	Ref #	HP/Modelo	Año	Ref #	HP/Modelo	Año	Ref #
DT25C	1989-98	18-7755	DT65	1985-97	18-7753	DT100	1989-98	18-7752
DT30C	1988-97	18-7755	DT75	1985-97	18-7754	DT115	1986-98	18-7754
DT40C	1984-98	18-7753	DT85	1985-98	18-7753	DT140	1986-98	18-7753
DT55	1985-97	18-7754	DT90	1989-97	18-7752	V-6	TODOS	18-7752

SEPARADORES COMBUSTIBLE/AGUA



Sierra ofrece una amplia gama de filtros separadores de agua de 10 y 21 micras incluyendo la cazoleta de drenaje para proteger tu carburador y la inyección.

Los filtros separadores de agua eliminan cerca del 98,8% del agua emulsionada de la gasolina. Los filtros Sierra de 10 micras tienen una eficiencia de cerca del 90% eliminando pequeñas partículas tan pequeñas como 10 micras. Todos los filtros tienen un caudal de 90 GPH. Los filtros Sierra de 10 micras son ideales para prevenir posibles daños en intrabordas sensibles y fueraborda de inyección.

Sierra #	Suzuki #	Descripción
18-7953	15410-87J30	Filtro combustible Para: DF25, DF70, DF90, DF115, DF140 (Incl.140T & 140Z) (2006 & Nuevo)
18-7936	15412-93J00	Elemento filtro combustible
18-7947	99105-20006	Filtro
18-7987	99105-20006-BWL	AquaVue™ Cazoleta mini / 187897E Easterner
18-7948	99105-20005	Filtro
18-7922-1	99105-20004BWL	AquaVue™ Cazoleta
18-7735	15410-94400	Kit filtro combustible
18-7711	15410-96J00	Filtro combustible (En línea)
18-7716	15410-87J10	Filtro combustible
18-7719	15410-98500	Filtro combustible

NEW



18-32154
SENSOR OXÍGENO
reemplaza: 18213-98J00
Para: DF100A, DF115A, DF140A, DF250A,
(2011-Up), DF300 (2007-Sup)

BOMBA COMBUSTIBLE



18-8002S
BOMBA COMB.
1/4" (6-7 mm).



18-8004 5/16"
112350 (8 mm).
BOMBA COMB.
5/16" (8 mm).
Bomba de gran capacidad

18-8005S 3/8"
112352 (8-10 mm).
BOMBA COMB.
3/8" (10 mm).
Bomba de gran capacidad



18-80409
CONECTOR COMBUSTIBLE
• 1/4" manguera
Tamaño motor
Reemplaza: 65720-94401
Para: DT4-DT65
Acoplable 18-80418



18-80418
CONECTOR COMBUSTIBLE
• 1/4" manguera
Reemplaza: 65750-94404
Para: DT4-DT140
Acoplable 18-80409, 18-8087 & 18-8090



18-80419
CONECTOR COMBUSTIBLE
Reemplaza: 65750-87J10, 65750-87J11
Para: DF25-DF140 (5/16" version de 18-80404)
Acoplable 18-80425



18-80425
CONECTOR COMBUSTIBLE
Reemplaza: 65720-986B0
Para: DF25-DF140
Acoplable 18-80404 & 18-80419



TABLA EQUIVALENCIA TURBINA SUZUKI

MOTOR SUZUKI	REFERENCIA SUZUKI	PRONAUTIC
DF4, DF5, DF6 (2011+)	17461-98400	18-3097
DF40A, DF50A, DF60A (2010+)	17461-96300	18-3096
DF60, DF70 (1997-2007)	17461-87E00	18-3049
DF70, DF80, DF90A (2009+)	17461-87E10	18-3049
DF150, DR175 (2006+)	17461-90J00	18-3023
DF200, DF225, DF250 (2011+)	17400-93J00	18-3264
DF200A A/P, DF150AP, DF175AP (2016+)	17461-94500	18-3023
DF250A, DF250S, DF300A (2011+)	17461-93J00	18-3035
DT2/2.2 DT 3,5, DT4, DT5, DT8	17461-98501, 17461-985M0	18-3097
DT8C, DT9,9C	17461-92D02	18-3000
DF8, DF9,9 DF15 (1997-2010)	17461-93902	18-3099
DT9,9, DT15	17461-93902	18-3099
DT14, DT16	17461-93001	18-3092
DT20, DT25	17461-96301	18-3096
DF25, DF30	17461-96312	18-3096
DT115, DT175, DT200, DT225	17461-90J01	18-3023
DT55, DT60, DT65, DT50, DT40	17461-94700	18-3094
DT60, DT75, DT85	17461-95300	18-3095

 <p>18-8062 CONECTOR COMBUSTIBLE • 3/8" barb Reemplaza: 65750-98505 Adaptable 18-8071</p>	 <p>18-8071 CONECTOR COMBUSTIBLE 1/4" NPT .432 D.E Reemplaza: 99105-00192 Adaptable 18-8062 (macho)</p>	 <p>18-8078 CONECTOR DEPÓSITO 1/4" N.P.T. .508 D.E Reemplaza: 65740-95500, 99105-00193 Para: Todos los modelos Adaptable 18-8079 (macho)</p>	 <p>18-8079 CONECTOR COMBUSTIBLE Terminal depósito Reemplaza: 65750-95510, 65750-95500 Para: Todos los modelos Acopable 18-8078 hembra 3/8" manguera</p>
 <p>18-8087 CONECTOR COMBUSTIBLE • 3/8" barb Lado motor Reemplaza: 65720-94411 Para: DT75-DT140 Adaptable 18-80418</p>	 <p>18-80404 CONECTOR COMBUSTIBLE 3/8" Para: DF25-DF140 HP Adaptable 18-80425</p>	 <p>112324 CONECTOR COMBUSTIBLE hembra 3/8" manguera Adaptable 18-8078</p>	 <p>18-8090 CONECTOR COMBUSTIBLE (1/4" NPT) Adaptable 18-80418</p>
 <p>18-3000 IMPULSOR Reemplaza: 17461-92D02 Para: DT 8C/9.9C (1989-97)</p>	 <p>18-3035 IMPULSOR Reemplaza: 17461-93J00 Para: DF200, DF225, DF250 (2004-05)</p>	 <p>18-3049 IMPULSOR Reemplaza: 17461-87E11, 17461-87E12 Para: DF 60/70 (1998-01), DF 90-100 (1989-01)</p>	 <p>18-3023 IMPULSOR Reemplaza: 17461-90J00, 17461-90J01, 17461-94500, 17461-94501, 17461-94502, 17461-94503, 17461-94504, 17461-94505, 17461-94506, 17461-94510, 17461-94511, 17461-94520 Para: 2 tiempos DF90, DF115, DF140 (2000-05), DT115 (1981-01), DT140 (1981-01), DT150 (1986-01), DT200 (1986-00)</p>
 <p>18-3092 IMPULSOR Reemplaza: 17461-93001, 17461-93003, 17461-93004</p>	 <p>18-3094 IMPULSOR Reemplaza: 17461-94700, 17461-94701</p>	 <p>18-3095 IMPULSOR Reemplaza: 17461-95300, 17461-95301, 17461-95302</p>	 <p>18-3096 IMPULSOR Reemplaza: 17461-96301, 17461-96311, 17461-96312</p>
 <p>18-3097 IMPULSOR Reemplaza: 17461-98501, 17461-98502, 17461-98503, 17461-98504</p>	 <p>18-3099 IMPULSOR Reemplaza: 17461-93902, 17461-93901, 17461-93903 Para: DT 9.9, 15 (1983-97), DF 9.9, 15 (1997-05)</p>	 <p>18-3291 LLAVE IMPULSOR Reemplaza: 09420-05006, 09420-05009 Para: V-6 2-tiempos (1986-03), DF90 /115/140(2001-04)</p>	 <p>18-3292 LLAVE IMPULSOR Reemplaza: 17462-93990, 09420-03005 Para: DT 8C/9.9C (1989-97), DF 9.9/15 (1997-04), DT 9.9 (1985-87), DT 15 (1983-88), DT 15C (1989-97)</p>
 <p>18-3296 LLAVE IMPULSOR Reemplaza: 09420-05005 Para: DT 115/140 (1983-01)</p>	 <p>18-3404 LLAVE IMPULSOR Reemplaza: 09420-04009 Para: DF 60/70 (1998-01), DF 90-100 (1989-01)</p>	 <p>18-3188 PLATINA IMPULSOR Reemplaza: 17471-98503 Para: DT 6 (1984-02), DT 8 (1986-97)</p>	 <p>18-3189 PLATINA IMPULSOR Reemplaza: 17471-87D01 Para: V-6 2-tiempos (1986-03)</p>



18-3190
PLATINA IMPULSOR
 Reemplaza: 17471-93902
 Para: DF 9.9/15 (1997-04), DT 9.9 (1985-87),
 DT 15 (1983-88), DT 15C (1989-97)



18-3191
PLATINA IMPULSOR
 Reemplaza: 17471-94501
 Para: DT 115/140 (1983-01)



18-3192
PLATINA IMPULSOR
 Reemplaza: 17471-87E01, 17471-92J00
 Para: DF 60/70 (1998-01), DF 90-100
 (1989-01), DF 90/115/140 (2001-04)



18-3193
PLATINA IMPULSOR
 Reemplaza: 17471-92D10
 Para: DT 8C/9.9C (1989-97)



18-3242
KIT REPARACIÓN IMPULSOR
 Reemplaza: 17400-96350,
 17400-96351, 17400-96353

- CONTIENE -			MODELO	AÑO	MODELO	AÑO
Ref #	Descripción	O.E. #	DT20	1986-88	DT35	1987-89
18-3096	Impulsor	17461-96311	DT25	1984-88	DT40C	1984-98
18-0461	Juntas	17472-96301	DT30	1984-87		



18-3243
KIT REPARACIÓN IMPULSOR
 Reemplaza: 17400-94700, 17400-94701

- CONTIENE -			MODELO	AÑO	MODELO	AÑO
Ref #	Descripción	O.E. #	18-3094	Impulsor	17461-94700	
18-0460	Juntas	17472-95310	DT55	1985-95	DT65	1985-95



18-3244
KIT REPARACIÓN IMPULSOR
 Reemplaza: 17400-95550, 17400-95350, 17400-95351
 Para: DT75, DT85 (1985-95)

- CONTIENE -		
Ref #	Descripción	O.E. #
18-3095	Impulsor	17461-95300
18-0459	Juntas	17472-95200



18-3253
KIT BOMBA DE AGUA
 Reemplaza: 17400-87D11
 Para: V6 2-tiempos (1986-03)

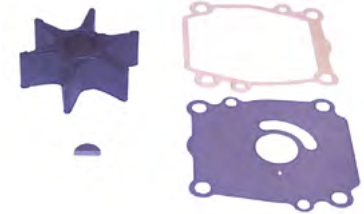

18-3254
KIT BOMBA DE AGUA
 Reemplaza: 17400-87E03, 17400-87E04
 Para: DF 60/70 (1998-06), DT 90-100 (1989-01)



18-3255
KIT BOMBA DE AGUA
 Reemplaza: 17400-92D01
 Para: DT 8C/9.9C (1989-97)



18-3256
KIT BOMBA DE AGUA
 Reemplaza: 17400-93951
 Para: DF 9.9/15 (1997-06), DT 9.9 (1985-87),
 DT 15 (1983-88), DT 15C (1989-97)



18-3257
KIT BOMBA DE AGUA
 Reemplaza: 17400-94611
 Para: DT 115/140 (1983-01)



18-3258
KIT BOMBA DE AGUA
 Reemplaza: 17400-90J11, 17400-90J20
 Para: DF 90/115/140 (2001-05)







18-3259
KIT BOMBA DE AGUA
 Reemplaza: 17400-98551
 Para: DT 6 (1984-02), DT8 (1986-97)







18-3260
KIT BOMBA DE AGUA
 Reemplaza: 17400-98652
 Para: DT 4 (1984-98), DT 5 (1999-02)



18-3264
KIT REPARACIÓN BOMBA DE AGUA
 Reemplaza: 17400-93J00,
 17400-93J02
 Para: DF200, DF225, DF250 (2004-09)

 <p>18-3266 KIT REPARACION BOMBA DE AGUA Reemplaza: 17400-98661 Para: DF4, DF6 (2003-07)</p>	 <p>18-3267 KIT BOMBA DE AGUA Reemplaza: 17400-98J00, 17400-98J01 Para: DF300 (2007-Actual)</p>	 <p>18-3480 BOMB. AGUA ALOJ. Reemplaza: 17411-93901 Para: DT9.9(1983-87, 2004-10), DT15(1983-87, 2004-10)</p>	 <p>18-3481 BOMB. AGUA ALOJ. Reemplaza: 17411-94421 Para: DF25(Todos modelos 2000-05) DF25(modelos DF25Q, DF25Q(QR), DF25T 2006-07), DF30(Todos 2000- 07), DT40C(1986-98), DF40(Todos 2000-07), DF50(Todos 1999-10)</p>
--	---	--	---

 <p>18-0761 JUNTA BOMBA Reemplaza: 17472-91J00 Para: DF4 (2003-05), DF6 (2003-05)</p>	 <p>18-0778 JUNTA BOMBA Reemplaza: 17472-93J00 Para: DF150(2006-10), DF175(2006-10), DF200(2004-10), DF225(2004-10), DF250(2004-10)</p>	 <p>18-0459 JUNTA BOMBA Reemplaza: 17472-95200</p>	 <p>18-0460 JUNTA BOMBA DE AGUA Reemplaza: 17472-95310</p>	 <p>18-0461 JUNTA BOMBA DE AGUA Reemplaza: 17472-96301</p>
--	--	---	--	---

<p>Pack. de 5</p>  <p>18-0477-9 JUNTA BOMBA DE AGUA Reemplaza: 17472-98503 Para: DT 6 (1984-02), DT8 (1986-97)</p>	 <p>18-0478 JUNTA BOMBA DE AGUA Reemplaza: 17472-93911 Para: DF 9.9/15 (1997-04), DT 9.9 (1985-87), DT 15 (1983-88), DT 15C (1989-97)</p>	 <p>18-0479 JUNTA BOMBA DE AGUA Reemplaza: 17472-92D10 Para: DT 8C/9.9C (1989-97)</p>	 <p>18-0792 JUNTA TERMOSTATO Reemplaza: 13119-91J00</p>	
---	--	--	---	--

 <p>18-0793 JUNTA TERMOSTATO Reemplaza: 17582-93J00</p>	 <p>18-0794 JUNTA TERMOSTATO Reemplaza: 17685-97J00</p>	 <p>18-0795 JUNTA TERMOSTATO Reemplaza: 17685-89J00</p>	 <p>18-0796 JUNTA TERMOSTATO Reemplaza: 17685-99E00</p>	 <p>18-0797 JUNTA TERMOSTATO Reemplaza: 17685-87D10</p>
--	--	--	---	--

HP/Modelo	Año	Impulsor	Junta	kit bomba de agua	HP/Modelo	Año	Impulsor	Junta	Kit bomba de agua
DT2/2.2	1983-97	18-3097	—	—	DT50M	1980-84	18-3094	18-0460	18-3243
DT3.5	1983-84	18-3097	—	—	DF50	1999-09	18-3096	18-0461	18-3242
DT4	1984-98	18-3097	18-0480	18-3260	DF50	2010	18-3096	18-0461	—
DF4	2003-10	18-3097	18-0761	18-3266	DT55	1985-97	18-3094	18-0460	18-3243
DT5	1977-83, 1999-02	18-3097	18-0480	18-3260	PU55 (jet)	1989-94	18-3094	18-0460	—
DT6	1984-02	18-3097	18-0477-9	18-3259	DT60	1983	18-3094	18-0460	18-3243
DF6	2003-10	18-3097	18-0761	18-3266	DT60	1984	18-3095	18-0460	—
DT8	1980-87	18-3097	18-0477-9	18-3259	DF60	1998-09	18-3049	—	—
DT8	1988-97	18-3000	18-0479	18-3255	DF60	2010	18-3096	18-0461	—
DF8	2010	18-3099	—	—	DT65	1982-prior	18-3094	18-0459	—
DT9.9	1977-82	18-3092	—	—	DT65	1985-97	18-3094	18-0460	18-3243
DT9.9	1983-87	18-3099	18-0478	18-3256	DF70	1998-09	18-3049	—	—
DT9.9	1988-97	18-3000	18-0479	18-3255	DF70	2010	18-3096	18-0461	—
DF9.9	1997-10	18-3099	18-0478	18-3256	DT75	1983-97	18-3095	18-0459	18-3244
DT14	1977-80	18-3092	—	—	DF80	2009-10	18-3049	—	—
DT15	1983-97	18-3099	18-0478	18-3256	DT85	1983-00	18-3095	18-0459	18-3244
DT15C	1989-97	18-3099	18-0478	—	PU85 (jet)	1989-97	18-3095	18-0459	—
DF15	1997-10	18-3099	18-0478	18-3256	DT90	1989-97	18-3049	—	18-3254
DT16	1977-82	18-3092	—	—	DF90	2001-08	18-3023	—	—
DT20	1986-88	18-3096	18-0461	18-3242	DF90	2009-10	18-3049	—	—
DT25	1980-82	18-3092	—	—	DT100	1987-01	18-3049	—	18-3254
DT25	1983-88	18-3096	18-0461	18-3242	DF100	2009-10	18-3023	—	—
DF25	2000-06	18-3096	18-0461	18-3242	DT115	1986-01	18-3023	—	18-3257 **
DF25 V-Twin	2006-10	18-3096	18-0461	—	DF115	2001-10	18-3023	—	18-3258 *
DT30	1983-87	18-3096	18-0461	18-3242	DT140	1986-01	18-3023	—	18-3257
DT30	1988-97	—	18-0461	—	DF140	2002-10	18-3023	—	—
DF30	2000-07	18-3096	18-0461	18-3242	DT150	1986-03	18-3023	—	18-3253
DT35	1980-82	18-3094	18-0459	—	DF150	2006-10	18-3023	18-0778	—
DT35	1987-89	18-3096	18-0461	18-3242	DT175	1987-92	18-3023	—	18-3253
DT40	1980-82	18-3094	18-0459	—	DF175	2006-10	18-3023	18-0778	—
DT40	1983	18-3096	18-0460	—	DT200	1986-00	18-3023	—	18-3253
DT40/DT40C	1984-98	18-3096	18-0461	18-3242	DF200	2004-10	18-3035	18-0778	18-3264
DF40	1999-09	18-3096	18-0461	18-3242	DT225	1990-03	18-3023	—	18-3253
DF40	2010	18-3096	18-0461	—	DF225	2004-10	18-3035	18-0778	18-3264
PU40 (jet)	1989-94	18-3096	18-0461	—	DF250	2004-10	18-3035	18-0778	18-3264
DT50	1982-prior	18-3094	18-0459	—	DF300	2007-10	18-3035	18-0651	18-3267
DT50	1983-84	18-3094	18-0460	18-3243	—	—	—	—	—

① Precio por envase

* SN 681517 & anterior

** SN 812175 & posterior



O.E. INTERCAMBIO		
Ref #	Descripción	O.E. #
18-39480	Aros pistón	12140-93121
18-39530	Aros piston	12140-96351-050
18-39540	Aros pistón	12140-94400
18-40110	Kit Pistón	12110-94400
18-40140	Kit Pistón	12110-93120
18-42850	Pasador pistón	12151-94400
18-42860	Pasador	12151-93100
18-42870	Pasador	12151-92502
18-42940-9 ① ②	Clips	09381-14001
18-42950-9 ① ②	Clips	09381-18002
18-42960-9 ① ②	Clips	09381-20003

HP/Modelo	Año	PISTON		AROS		PASADOR		CLIPS	
		Std.	.50mm	Std.	.50mm	Std.	.50mm	Std.	.50mm
DT9.9	1983-87	18-40140	—	18-39480	—	18-42860	—	18-42940-9	—
DT15	1983-88	18-40140	—	18-39480	—	18-42860	—	18-42940-9	—
DT25	1983-88	—	—	—	18-39530	—	18-42870	—	18-42950-9
DT30	1983-87	—	—	—	18-39530	—	18-42870	—	18-42950-9
DT40	1984-98	18-40110	—	18-39540	—	18-42850	—	18-42960-9	—

<p>18-1757 BIELA Reemplaza: 12161-93902 Para: DT9.9, DT15 (1983-97)</p>	<p>18-1758 BIELA Reemplaza: 12161-96300, 12161-91L00 Para: DT25 (1983-88), DT30 (1983-87)</p>	<p>18-1759 BIELA Reemplaza: 12161-94400, 12161-92L00 Para: DT 40 (1984-98)</p>	<p>18-1757K KIT CONEXIÓN Reemplaza: 12161-93902 Para: DT9.9 (1983-87), DT15 (1983-97)</p>
--	--	---	--

<p>18-1759K KIT CONEXIÓN Reemplaza: 12161-94400 Para: DT40 (1986-98)</p>	<p>18-1412 COJINETE Reemplaza: 09263-20051 Para: DT9.9 (1983-87), DT15 (1983-97)</p>	<p>18-1414 COJINETE Reemplaza: 09263-14022 Para: DT9.9 (1983-87), DT15 (1983-97), DT14/16 (1980-82)</p>	<p>18-1415 COJINETE Reemplaza: 09263-18016 Para: DT25 (1983-88), DT30 (1983-87)</p>
---	---	--	--

<p>18-1416 COJINETE Reemplaza: 09263-27005 Para: 40 (1984-98)</p>	<p>18-1417 COJINETE Reemplaza: 09263-20072 Para: 40 (1984-98)</p>	<p>18-3806 JUNTA CULATA Reemplaza: 11141-98401, 11141-98411</p>	<p>18-3807 JUNTA CULATA Reemplaza: 11141-98101, 11141-98130</p>
--	--	--	--

<p>18-3808 JUNTA CULATA Reemplaza: 11141-93901, 11141-93960</p>	<p>18-3809 JUNTA CULATA Reemplaza: 11141-96303, 11141-96344</p>	<p>18-3810 JUNTA CULATA Reemplaza: 11141-94401, 11141-94450</p>	<p>18-3813 JUNTA CULATA Reemplaza: 11141-95305, 11141-95320</p>
--	--	--	--



18-3814
JUNTA CULATA
Reemplaza: 11141-95505, 11141-95512



18-3816
JUNTA CULATA
Reemplaza: 11141-98504, 11141-98510, 11141-98522

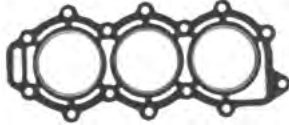

18-3819
JUNTA CULATA
Reemplaza: 11141-95D90, 11141-95D10



18-3820
JUNTA CULATA
Reemplaza: 11141-94701, 11141-94702, 11141-94720

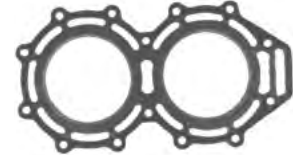

18-3822
JUNTA CULATA
Reemplaza: 11141-87E90, 11141-87E10



18-3823
JUNTA CULATA
Reemplaza: 11141-94506, 11141-94620



18-3824
JUNTA CULATA
Reemplaza: 11141-94600, 11141-94620



18-3825
JUNTA CULATA
Reemplaza: 11141-87D90, 11141-87D60

Modelo	Año	Cil	Junta Culata	Modelo	Año	Cil	Junta Culata	Modelo	Año	Cil	Junta Culata
2	1983-89	1	18-3806	25	1989	3	18-3819	85	1983-87	3	18-3814
5	1983	2	18-3816	30	1983-87	2	18-3809	90	1989	V-4	18-3822
6	1984-89	2	18-3807	30	1988-89	3	18-3819	100	1989	V-4	18-3822
8	1983-87	2	18-3807	35	1987-89	2	18-3810	115	1983-85	4	18-3823
8	1988-89	2	-	40	1984-89	2	18-3810	115	1986-89	4	18-3824
9.9	1983-87	2	18-3808	50	1984	2	18-3813	140	1983-85	4	18-3823
9.9	1988-89	2	-	55	1985-89	3	18-3820	140	1986-89	4	18-3824
15	1983-89	2	18-3808	65	1985-89	3	18-3820	150	1986	V-6	18-3825
25	1983-88	2	18-3809	75	1983-87	3	18-3814	200	1986	V-6	18-3825



18-7895
FILTRO ACEITE
Reemplaza: 16510-93J00
Rosca: 3/4" x 16NPT



18-7896
FILTRO ACEITE
187896E Easterner
Reemplaza: 16510-61A20-MHL
Para: DF70A, DF80A, DF90A, DF90-DF115



18-7897
FILTRO ACEITE
187897E Easterner
Reemplaza: 16510-82703
Para: DF140

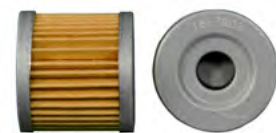

18-7903
FILTRO ACEITE
Reemplaza: 16510-05240
Reemplaza: DF9.9, DF15 (1996-06)



18-79051
FILTRO ACEITE
1879051 Easterner
Reemplaza: 16510-96J00
Para: DF150-DF300



18-7915-1
FILTRO ACEITE
1879151E Easterner
Reemplaza: 16510-87J00
Para: DF25-DF70

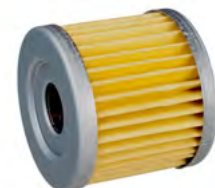

18-8870
FILTRO ACEITE
Reemplaza: 16510-45H10
Para: F9.9 Tipo T/TH(Sn 110001 & nuevo), F15(SN 110001 & Nuevo)

Junta culata / Filtro aceite
SUZUKI

 <p>18-0650 JUNTA ALOJAMIENTO RETÉN DE ACEITE Reemplaza: 56132-95J00 Para: F 25 V-Twin (2006-07)</p>	 <p>18-0651 JUNTA PANEL BOMBA Reemplaza: 17472-98J00 Para: F300 (2007)</p>	 <p>Pack. de 5 18-8331 18-8331-9① JUNTA TORNILLO DRENAJE Reemplaza: 09168-10022</p>	 <p>18-8334 RETÉN EJE HÉLICE Reemplaza: 25223-94400</p>																																									
 <p>Pack. de 10 PASADOR</p> <table border="1"> <thead> <tr> <th>Ref #</th> <th>Reemplaza</th> </tr> </thead> <tbody> <tr> <td>18-3737 ②</td> <td>09204-02004</td> </tr> <tr> <td colspan="2">Para: DT9.9 & 15C, DF9.9 & 15, 8 & 9.9C inyección aceite</td> </tr> <tr> <td>18-3735 ②</td> <td>09204-03003, 09204-03004</td> </tr> <tr> <td colspan="2">Para: DT20, 25C, 30C</td> </tr> </tbody> </table>	Ref #	Reemplaza	18-3737 ②	09204-02004	Para: DT9.9 & 15C, DF9.9 & 15, 8 & 9.9C inyección aceite		18-3735 ②	09204-03003, 09204-03004	Para: DT20, 25C, 30C		 <p>18-3726 TUERCA HÉLICE Reemplaza: 09141-18005</p>	 <p>18-3710 TUERCA HÉLICE Reemplaza: 09141-14008</p>	 <p>18-3774 KIT TUERCA HÉLICE Reemplaza: 57630-94500 Para: DT75/85/90/100/115, 140 con stilo V, DF60/70 con stilo V — CONTIENE —</p> <table border="1"> <thead> <tr> <th>Ref #</th> <th>O.E. #</th> <th>Desc.</th> </tr> </thead> <tbody> <tr> <td>18-3726</td> <td>09141-18005</td> <td>Tuerca</td> </tr> <tr> <td>18-3735</td> <td>09204-03003, 09204-03004</td> <td>Pasador</td> </tr> <tr> <td>—</td> <td>09160-18028</td> <td>Arandela</td> </tr> <tr> <td>—</td> <td>57633-94500</td> <td>Espaciador</td> </tr> </tbody> </table>	Ref #	O.E. #	Desc.	18-3726	09141-18005	Tuerca	18-3735	09204-03003, 09204-03004	Pasador	—	09160-18028	Arandela	—	57633-94500	Espaciador																
Ref #	Reemplaza																																											
18-3737 ②	09204-02004																																											
Para: DT9.9 & 15C, DF9.9 & 15, 8 & 9.9C inyección aceite																																												
18-3735 ②	09204-03003, 09204-03004																																											
Para: DT20, 25C, 30C																																												
Ref #	O.E. #	Desc.																																										
18-3726	09141-18005	Tuerca																																										
18-3735	09204-03003, 09204-03004	Pasador																																										
—	09160-18028	Arandela																																										
—	57633-94500	Espaciador																																										
 <p>18-3775 KIT TUERCAS HÉLICE Reemplaza: 57630-92E00 Para: V-6 — CONTIENE —</p> <table border="1"> <thead> <tr> <th>Ref #</th> <th>O.E. #</th> <th>Descripción</th> </tr> </thead> <tbody> <tr> <td>18-3726</td> <td>09141-18005</td> <td>Tuerca</td> </tr> <tr> <td>18-3735</td> <td>09204-03003, 09204-03004</td> <td>Pasador</td> </tr> <tr> <td>—</td> <td>09160-18019</td> <td>Arandela</td> </tr> <tr> <td>18-3795</td> <td>57633-87D30</td> <td>Espaciador</td> </tr> </tbody> </table>	Ref #	O.E. #	Descripción	18-3726	09141-18005	Tuerca	18-3735	09204-03003, 09204-03004	Pasador	—	09160-18019	Arandela	18-3795	57633-87D30	Espaciador	 <p>18-3777 KIT TUERCAS HÉLICE Reemplaza: 57630-94300 Para: DT40/55/65 — CONTIENE —</p> <table border="1"> <thead> <tr> <th>Ref #</th> <th>O.E. #</th> <th>Descripción</th> </tr> </thead> <tbody> <tr> <td>18-3726</td> <td>09141-18005</td> <td>Tuerca</td> </tr> <tr> <td>18-3735</td> <td>09204-03003, 09204-03004</td> <td>Pasador</td> </tr> <tr> <td>—</td> <td>09160-18028</td> <td>Arandela</td> </tr> </tbody> </table>	Ref #	O.E. #	Descripción	18-3726	09141-18005	Tuerca	18-3735	09204-03003, 09204-03004	Pasador	—	09160-18028	Arandela	 <p>18-3778 KIT TUERCA HÉLICE Reemplaza: 57630-96300 Para: DT20/25C/30C — CONTIENE —</p> <table border="1"> <thead> <tr> <th>Ref #</th> <th>O.E. #</th> <th>Descripción</th> </tr> </thead> <tbody> <tr> <td>18-3735</td> <td>09204-03003, 09204-03004</td> <td>Pasador</td> </tr> <tr> <td>—</td> <td>09160-14028</td> <td>Arandela</td> </tr> <tr> <td>18-3710</td> <td>09141-14008</td> <td>Tuerca</td> </tr> <tr> <td>—</td> <td>57633-96300</td> <td>Espaciador</td> </tr> </tbody> </table>	Ref #	O.E. #	Descripción	18-3735	09204-03003, 09204-03004	Pasador	—	09160-14028	Arandela	18-3710	09141-14008	Tuerca	—	57633-96300	Espaciador
Ref #	O.E. #	Descripción																																										
18-3726	09141-18005	Tuerca																																										
18-3735	09204-03003, 09204-03004	Pasador																																										
—	09160-18019	Arandela																																										
18-3795	57633-87D30	Espaciador																																										
Ref #	O.E. #	Descripción																																										
18-3726	09141-18005	Tuerca																																										
18-3735	09204-03003, 09204-03004	Pasador																																										
—	09160-18028	Arandela																																										
Ref #	O.E. #	Descripción																																										
18-3735	09204-03003, 09204-03004	Pasador																																										
—	09160-14028	Arandela																																										
18-3710	09141-14008	Tuerca																																										
—	57633-96300	Espaciador																																										
 <p>③ 025344 Zinc ÁNODO Reemplaza: 55320-95310 55-140 HP</p>	 <p>③ 025844 Zinc ÁNODO Reemplaza: 55125-87D00 150-200 HP</p>	 <p>③ 025341 Zinc ÁNODO Reemplaza: 55125-96310 DF25, DF30, DT20, DT25, DT25C, DT30, DT30C, DT35</p>																																										
 <p>009360 Zinc Reemplaza: 11130-94600</p>	 <p>025842 Zinc Reemplaza: 55321-93900</p>	 <p>025343 Zinc Reemplaza: 55320-98600 y 5030267</p>																																										
<p>① Precio por envase ② Precio por pieza. Para pedir envasado añada 9 al final de la referencia ⑤ Aluminio ④ Magnesio ③ Zinc</p>																																												



025345 Zinc
Reemplaza: 41810-87D00 y Yamaha 6ES-45251-00



025843 Zinc
Reemplaza: 55125-95301



025401 Zinc
Reemplaza: 11281-94400 y Yamaha 676-11325-00



025342 Zinc
Reemplaza: 55125-95500



025834 Zinc
Reemplaza: 55321-90J01
Para motores DF 90/140hp.



025742 Zinc
Reemplaza: 55320-94900.
Barra para Suzuki. Transom DF60-DF300 (2001-2010) DT115-DT140 (1996-2001).



18-79989
STICKS ARRASTRE
Para: Mayoría fuerabordas 150hp con tilt/trim integral.



18-8380
KIT RETENES PARTE INFERIOR
Reemplaza: 25700-93J00
Para: Todos DF150/DF175/DF200/DF225/DF250

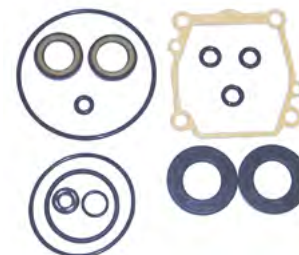

18-8381
KIT RETENES PARTE INFERIOR
Reemplaza: 25700-99E00
Para: DF 60(2001 & Sup), DF70(2001 & Sup)



**THE
VERY BEST
PARTS OF
BOATING**



Sistema de transmisión / Kit retenes
SUZUKI

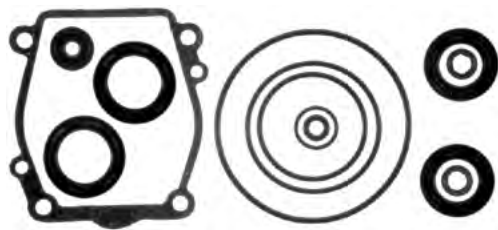

18-8335
KIT RETENES UNIDAD INFERIOR
 Reemplaza: 25700-87D00

— CONTIENE —

Ref #	Descripción	O.E. #	Cant.
18-7118	Aro	09280-08008	1
18-7183	Aro	09280-69001	1
18-8331	Junta tornillo drenaje	09168-10022	2
18-7440-1	Aro	—	1
18-0544	Retén aceite	09282-24004	2

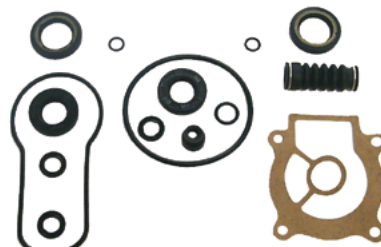

18-8337
KIT RETENES UNIDAD INFERIOR
 Reemplaza: 25700-94400

— CONTIENE —

Ref #	Descripción	O.E. #	Cant.
18-0461	Junta bomba de agua	17472-96301	1
18-7151	Aro	09280-75001	1
18-7413	Aro	09280-08005	2
18-8331	Junta tornillo drenaje	09168-10022	3
18-8334	Retén eje gas	25223-94400	1
18-8345	Retén	09289-22007	2
18-7180	Aro	—	1

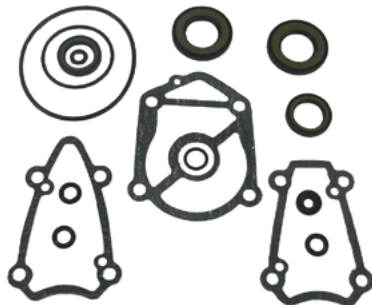

18-8338
KIT RETENES UNIDAD INFERIOR
 Reemplaza: 25700-94500

— CONTIENE —

Ref #	Descripción	O.E. #	Cant.
18-7118	Aro	09280-08008	1
18-8331	Junta tornillo drenaje	09168-10022	3
18-7182	Retén aceite	—	1
18-7133	Aro	—	1

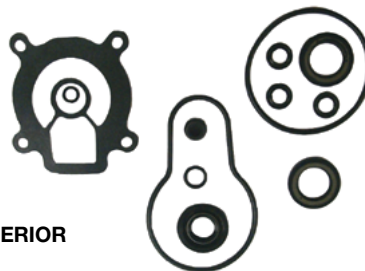

18-8339
KIT RETENES UNIDAD INFERIOR
 Reemplaza: 25700-94700

— CONTIENE —

Ref #	Descripción	O.E. #	Cant.
18-0460	Junta bomba de agua	17472-95310	1
18-7151	Aro	09280-76006	1
18-7180	Aro	—	1
18-7413	Aro	09280-08005	1
18-8329	Retén	09289-17005	1
18-8331	Junta tornillo drenaje	09168-10022	3
18-8334	Retén eje gas	25223-94400	1
18-8345	Retén	09289-22007	2

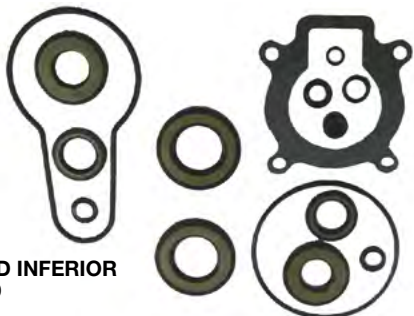

18-8340
KIT RETENES UNIDAD INFERIOR
 Reemplaza: 25700-95500

— CONTIENE —

Ref #	Descripción	O.E. #	Cant.
18-0459	Junta bomba de agua	17472-95200	1
18-8331	Junta tornillo drenaje	09168-10022	3
18-8334	Retén eje gas	25223-94400	1
18-7180	Aro	—	1
18-7413	Aro	09280-08005	1
18-7127	Aro	—	1



18-8341
KIT RETENES UNIDAD INFERIOR
 Reemplaza: 25700-95D00

— CONTIENE —

Ref #	Descripción	O.E. #	Cant.
18-0461	Junta bomba de agua	17472-96301	1
18-7118	Aro	09280-50005	1
18-7413	Aro	09280-08005	1
18-7140	Aro	09282-17006	1
18-8331	Junta tornillo drenaje	09168-10022	3



18-8373
KIT RETENES UNIDAD INFERIOR
 Reemplaza: 25700-90J01
 Para: DF 90/115 todos los años



18-8374
KIT RETENES UNIDAD INFERIOR
 Reemplaza: 25700-92J00
 Para: DF140 (Todos los años)

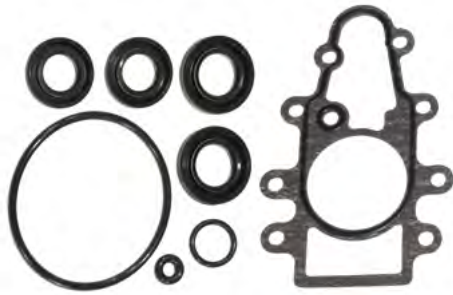

18-8385
KIT RETENES
 Reemplaza: 25700-95J00
 Para: DF25 V-Twin (2006-07)

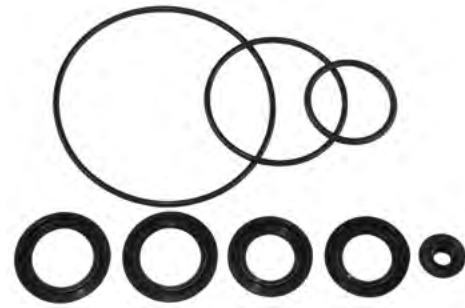

18-8386
KIT RETENES
 Reemplaza: 25700-98J00
 Para: DF300 (2007)

APLICACIÓN KIT RETENES

HP/MODELO	Año	Ref #	HP/MODELO	Año	Ref #
DT25C	Todos	18-8341	DT115	Todos	18-8338
DF25	Todos	18-8341	DF115	Todos	18-8373
DF25 V-Twin	2006-07	18-8385	DT140	Todos	18-8338
DT30C	Todos	18-8341	DF140	Todos	18-8374
DF30	Todos	18-8341	DT150	Todos	18-8335
DT40C	Todos	18-8337	DF150	Todos	18-8380
DF40	Todos	18-8337	DT175	Todos	18-8335
DF50	Todos	18-8337	DF175	Todos	18-8380
DT55	Todos	18-8339	DT200	Todos	18-8335
DF60	2001-07	18-8381	DF200	Todos	18-8380
DT65	Todos	18-8339	DT225	Todos	18-8335
DF70	2001-07	18-8381	DF225	Todos	18-8380
DT75	18-8340		DF250	Todos	18-8380
DT85	Todos	18-8340	DF300	Todos	18-8386
DF90	Todos	18-8373			

Pack. de 2



RETÉN ACEITE

Ref #	O.E. #	D.I.	Dimensiones D.E. (mm)	Ancho
18-0544	09282-24004	23.2	40.3	7
18-0545	09289-10002	9	22.2	8
18-0551	09283-10011	9	22.2	8
18-0569	09284-08003			
18-8345	09289-22007	22.2	35	5
18-8375		29	45	6
18-8378		8	22	7

Pack. de 5

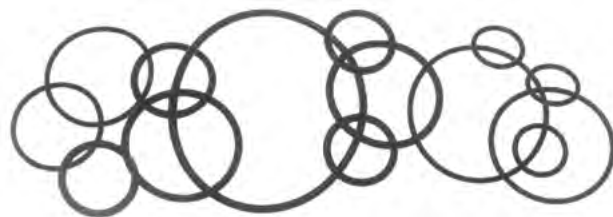

ARO

Referencia	O.E. No.	Dimensiones	
		D. I.	Ancho (mm)
18-7118 ①	09280-08008	69.40	3.10
18-7140 ①	09280-75002	69.00	3.50

① Precio por pieza. Para ordenarlo pida la misma ref. acabada en 9.

SUZUKI



SUZUKI



MOD.-HP	AÑO	Ref. CHAMPION	Ref. PRONAUTIC	MOD.-HP	AÑO	Ref. CHAMPION	Ref. PRONAUTIC
DT2	1977-96	L90C	051028	DT150 V6 EFI	1986-94	QL78C/L78C	050915/050907
DT2.2	1997+	L90C	051028	DT175 V6	1991-93	QL78C/L78C	050915/050907
DT3.5	1979-84	QL87YC/L87YC	050920/050938	DT200 EFI	1986+	QL78C/L78C	050915/050907
DT4	1985-98	QL87YC/L87YC	050920/050938	DT225 EFI	1991+	QL78C/L78C	050915/050907
DT4.5	1977+	QL86C/L86C	050919/050910	4 TIEMPOS			
DT5	1978-83	QL87YC/L87YC	050920/050938	DF4	2003-04	RN9YC	050948
DT5Y	1999-01	QL82YC/L82YC	050918/050909	DF6	2003-04	RN9YC	050948
DT6	1984-97	QL87YC/L87YC	050920/050938	DF9.9	1997-04	RA8HC	050957
DT6	1998-01	QL87YC/L87YC	050920/050938	DF15	1997-04	RA8HC	050957
DT7.5	1977-79	QL86C/L86C	050919/050910	DF25	2000-04	RA8HC	050957
DT8	1980-87	QL87YC	050920	DF30	2000-04	RA8HC	050957
DT9	1977-79	QL86C/L86C	050919/050910	DF40	1999-04	RA8HC	050957
DT9	1993	QL86C/L86C	050919/050910	DF50	1999-04	RA8HC	050957
DT9.9C	1983-97	QL82C/L82C	050918/050909	DF60	1998-04	RN9YC	050948
DT15	1983-88	QL86C	050919	DF70	1998-04	RN9YC	050948
DT15C	1989-97	QL82C	050918	DF90	2001-04	RC9YC	050943
T16	1977-82	QL86C/L86C	050919/050910	DF115	2001-04	RC9YC	050943
DT20	1977-88	QL82C/L82C	050918/050909	DF140	2002-04	RC9YC	050943
DT25C	1977-00	QL82C/L82C	050918/050909				
DT30C	1989+	QL82C/L82C	050918/050909				
DT35	1989+	QL82C/L82C	050918/050909				
DT40	1980-98	QL78C/L78C	050915/050907				
DT50	1997-84	QL78C/L78C	050915/050907				
DT55	1985-97	QL78C/L78C	050915/050907				
DT60	1983-84	QL78C/L78C	050915/050907				
DT65	1978-97	QL78C/L78C	050915/050907				
DT75	1983-97	QL78C/L78C	050915/050907				
DT85	1979-97	QL78C/L78C	050915/050907				
DT85	1998+	QL78C/L78C	050915/050907				
DT90 V4	1989-97	QL78C/L78C	050915/050907				
DT100 V4	1989-01	QL78C/L78C	050915/050907				
DT115 Carb	1981-97	QL78C/L78C	050915/050907				
DT115 EFI	1996-01	QL78C/L78C	050915/050907				
DT115S EFI	1998+	QL78C/L78C	050915/050907				
DT140 Carb	1981-96	QL78C/L78C	050915/050907				
DT140 EFI	1997-01	QL78C/L78C	050915/050907				

SUZUKI**SUZUKI**

MOD. -HP	AÑO	Ref. NGK	Ref. PRONAUTIC	MOD. -HP	AÑO	Ref. NGK	Ref. PRONAUTIC
DT2	1986-90	BR4HS	050830	DT15K	-1985	BR6HS	050714
DT2	1991-99	BR5HS	050892	DT15K	1986+	B6HS	050804
DT2.2	1992+	BR5HS	050892	DT20	1997-00	BR7HS-10	050832
DT4	1988-92	BP5HS	050855	DT20/P	-1985	BR7HS	050853
DT4	1993-01	BPR5HS	050874	DT20/P	1986+	BR7HS-10	050832
DT4.5		BR6HS	050714	DT20K	-1985	BR7HS-10	050832
DT4L/S	1994+	BPR5HS	050874	DT20K	1986-87	B7HS-10	050807
DT4L/S	-1993	BP5HS	050855	DT25	-1985	BR7HS	050853
DT5	1986-92	BP6HS	050820	DT25	2000-01	BR7HS-10	050832
DT5	1993-94	BPR6HS	050827	DT25C	1989-97	BR7HS-10	050832
DT5	1995-00	BR6HS	050714	DT25E	1983-85	BPR7HS-10	050843
DT5W	1986-92	BR6HS	050714	DT25E	-1982	B7HS	050806
DT5Y	1998-01	BPR7HS-10	050843	DT25E	1986+	BR7HS-10	050832
DT6	1986-92	B6HS-10	050732	DT25K	1986+	BR7HS-10	050832
DT6	1993-02	BR6HS	050714	DT28P/DT28/ DT28E		B7HS	050806
DT6	-1985	B6HS	050804	DT30	1986+	BR7HS-10	050832
DT6	1995-99	BR6HS-10	050880	DT30	1983-85	BR7HS-10	050832
DT6S/5PS	-1992	B6HS	050804	DT30C	1988-00	BR7HS-10	050832
DT7.5		BR6HS	050714	DT30E	1983+	BR7HS-10	050832
DT8	1986-02	BPR6HS	050827	DT40	-1983	B8HS	050809
DT8C	1988-97	BR6HS-10	050880	DT40C	1986-99	B8HS-10	050810
DT9		B6HS-10	050732	DT40C/CR/TC	1998+	B8HS-10	050810
DT9.9	1986-99	BR7HS-10	050832	DT40W	1995+	B7HS-10	050807
DT9.9	1977-78	B7HS	050806	DT40WK	1998+	B7HS-10	050807
DT9.9	1979-84	BR6HS	050714	DT40WK	-1997	B7HS	050806
DT9.9	1976	B6HS	050804	DT48M	2001+	B8HS-10	050810
DT9.9C	1988-97	BR6HS-10	050880	DT48M	-2000	B8HS	050809
DT9.9E	1982+	B6HS	050804	DT50	1979-83	B8HS	050809
DT9.9E	1984+	B7HS	050806	DT50	-1978	B7HS	050806
DT9.9E	1983+	BR7HS-10	050832	DT50	1984-89	B8HS-10	050810
DT9.9K	1985-86	B6HS	050804	DT50ACR	1994-96	B8HS-10	050810
DT9.9K	-1985	BR6HS	050714	DT50ACR	1993	BR8HS	050854
DT9.9K	1986-90	B6HS	050804	DT50C	1984-00	B8HS-10	050810
DT9.9P	-1983	BPR6HS	050827	DT50K		B7HS	050806
DT15	1986-02	BR7HS-10	050832	DT50M/DT50	1986-89	B8HS-10	050810
DT15C	1989-97	BR7HS-10	050832	DT50M/DT50	-1985	B8HS	050809

SUZUKI**SUZUKI**

MOD. -HP	AÑO	Ref. NGK	Ref. PRONAUTIC	MOD. -HP	AÑO	Ref. NGK	Ref. PRONAUTIC
DT50M/DT50	2001+	BR8HS-10	050835	DT90TC	1996-97	BR8HS	050854
DT55C	1988-98	BR8HS-10	050835	DT90TC	-1995	BR8HCS-10	050737
DT55M/MQ	-2000	B8HS	050809	DT90TC	1998+	BR8HS-10	050835
DT55M/MQ	2001+	BR8HS-10	050835	DT100	2001+	BR8HS-10	050835
DT55TC/CRQ	1998+	BR8HS-10	050835	DT100	1996-00	BR8HS-10	050835
DT60		B8HS-10	050810	DT100	1990-95	BR8HCS-10	050737
DT60C	2001+	BR8HS-10	050835	DT100	2000	BR8HCS-10	050737
DT60C	1986-87	B8HS-10	050810	DT100TC	-1995	BR8HCS-10	050737
DT65/T	-1983	BR8HS	050854	DT100TC	1998+	BR8HS-10	050835
DT65C	1988-99	BR8HS-10	050835	DT100TC	1996-97	BR8HS	050854
DT65TC	1994-95	BR8HS-10	050835	DT115	-1990	B8HS	050809
DT75/85	1990-92	B8HS	050809	DT115	1992+	BR8HCS-10	050737
DT75/85	1993-00	BR8HS-10	050835	DT115C	1991-93	BR8HCS-10	050737
DT75C	2001+	BR8HS-10	050835	DT115C	-1990	B8HS	050809
DT75C	1993-00	B8HS	050809	DT115C	2001+	BR8HS-10	050835
DT75M	2001+	BR8HS-10	050835	DT115S	1996+	BR8HS-10	050835
DT75M	-2000	BR8HS	050854	DT115STC	1996+	BR8HS-10	050835
DT75TC	-2000	B8HS	050809	DT115TC	-1988	B8HS-10	050810
DT75TC	2001+	BR8HS-10	050835	DT115TC		BR8HCS-10	050737
DT85	-1992	BR8HS	050854	DT115TC(EFI)		BR8HS-10	050835
DT85C	2001+	BR8HS-10	050835	DT140	1992+	BR8HCS-10	050737
DT85C	1993-00	BR8HS	050854	DT1140	-1990	B8HS	050809
DT85C	-1992	BR8HS	050854	DT140EFI	1996+	BR8HS-10	050835
DT85M	2001+	BR8HS-10	050835	DT140C	1991-1996	BR8HCS-10	050737
DT85M	-2000	BR8HS	050854	DT1140C	-1990	B8HS	050809
DT85MQ	1995-96	B8HS-10	050810	DT140C EFI	1997+	BR8HCS-10	050737
DT85Q	2001+	BR8HS-10	050835	DT140T	-2000	BR8HCS-10	050737
DT85Q	-2000	BR8HS	050854	DT140T	2001+	BR8HS-10	050835
DT85TC	-2000	B8HS	050809	DT140TC	-2000	BR8HCS-10	050737
DT85TC	2001+	BR8HS-10	050835	DT140TC EFI		BR8HS-10	050835
DT85W	2001+	B8HS-10	050810	DT150	1987-02	BR8HS-10	050835
DT85W	-2000	BR8HS	050854	DT150G		BR8HS-10	050835
DT85WT	2001+	B8HS-10	050810	DT150S		BR8HS-10	050835
DT85WT	1995-96	B8HS-10	050810	DT150SS		BR8HS-10	050835
DT90	-2000	BR8HCS-10	050737	DT150STC		BR8HS-10	050835
DT90	2001+	BR8HS-10	050835	DT150TC	1989+	BR8HS-10	050835

SUZUKI

MOD. -HP	AÑO	Ref. NGK	Ref. PRONAUTIC
DT150TC EFI		BR8HS-10	050835
DT175	1989-02	BR8HS-10	050835
DT175TC	-1988	B8HS-10	050810
DT175TC	1989+	BR8HS-10	050835
DT200	1989-02	BR8HS-10	050835
DT200G		BR8HS-10	050835
DT200T		BR8HS-10	050835
DT200TC	1989+	BR8HS-10	050835
DT200V		BR8HS-10	050835
DT225	1991-02	BR8HS-10	050835
DT225TC		BR8HS-10	050835
DT225TCL EFI		BR8HS	050854
4 TIEMPOS			
DF4	2002+	BPR6ES	050826
DF5	2002+	BPR6ES	050826
DF6	2002+	BPR6ES	050826
DF9.9AEL	1995+	DCPR6E	050859
DF9.9AES	1995+	DCPR6E	050859
DF9.9AL	1995+	DCPR6E	050859
DF9.9AS	1995+	DCPR6E	050859
DF15AL	1995-99	DCPR6E	050859
DF15ARL	1995-99	DCPR6E	050859
DF15ARS	1995-99	DCPR6E	050859
DF15AS	1995-99	DCPR6E	050859
DF25	2000+	DCPR6E	050859
DF30	2000+	DCPR6E	050859
DF40	1999+	DCPR6E	050859
DF50	1999+	DCPR6E	050859
DF60	1998+	BPR6ES	050826
DF70	1998+	BPR6ES	050826
DF90	2001+	BPR6E	050738
DF115	2001+	BPR6E	050738
DF140	2002+	BPR6E	050738
DF200	2004+	BPR6E	050738
DF225	2004+	BPR6E	050738
DF250	2004+	BPR6E	050738



HÉLICES BAEKSAN

Baeksan fabrica miles de hélices desde el año 1984. Nuestras helices de altas prestaciones fabricadas con los mejores materiales aseguran una larga vida y una navegación tranquila y sin sobresaltos.

Sus palas compensadas ofrecen una reducción significativa de la vibraciones.

Cojinete de goma insertado en el nucleo en versión fija o nucleo intercambiable.





Mano de pintura de alto grosor para evitar la corrosión.

En caso de no conocer la referencia original de la hélice a reemplazar siga los siguientes pasos:

- 1-Comprueba el rango de Revoluciones por minuto (RPM) del fabricante del motor en el manual.
- 2-Comprueba las RPM maximas del motor leyendo el panel para determinar el paso y velocidad optimo.
- 3-Si las RPM maximas exceden el rango recomendado, disminuye las RPM utilizando un paso superior.
- 4-Si las RPM son mas bajas que el rango recomendado, aumenta las RPM utilizando un paso inferior.

Si no localiza la hélice que necesita contacte con nuestro departamento técnico.

Tipo	Modelo Fueraborda	Referencia-Diam./Paso	Ref. original	Palas	Núcleo
A	 <p>8 - 20 hp 2-1/2" Caja de engranajes</p> <ul style="list-style-type: none"> • DF 8A (4 tiempos) 2011 y posteriores • DT 9.9 1983-1987 • DF 9.9 (4 tiempos) 1996 y posteriores • DF 9.9A / 9.9B (4 tiempos) 2010 y posteriores • DT 15 1983-1988 • DT 15C 1989-1997 • DF 15 (4 tiempos) 1996 y posteriores • DF 15A / 20A (4 tiempos) 2013 y posteriores <p>Escape a través del núcleo, 10 estrias</p>	62S159148 9 1/4x8		3	Fijo
		62S159149 9 1/4x9	58100-94J00-019	3	
		62S1591410 9 1/4x10	58100-93733-019	3	
		62S1591411 9 1/4x11	58100-93743-019	3	
		62S1591412 9 1/4x12		3	
		62S15F9148 9 1/4x8	58100-90L40-019	3	
		62S15F9149 9 1/4x9	58100-89L20-019	3	
		62S15F91410 9 1/4x10	58100-89L30-019	3	
		62S15F91411 9 1/4x11	58100-89L40-019	3	
		62S15F91412 9 1/4x12	58100-89L50-019	3	
B	 <p>20 - 30 hp 3" Caja de engranajes</p> <ul style="list-style-type: none"> • DT 20 1987-1988 • DT 25 1987-1988 • DT 25C 1989-2000 • DF 25 (4 tiempos) 2000 y posteriores • DF 25R 2010 y posteriores • DF 25A 2014 y posteriores • DT 30, 30C 1987-1997 • DF 30 (4 tiempos) 2000-2007 • DF 30A 2014 y posteriores <p>Para motores Johnson/Evinrude:</p> <ul style="list-style-type: none"> • 25hp (4 tiempos) 2004 y posteriores • 30hp (4 tiempos) 2004 y posteriores <p>Escape a través del núcleo, 10 estrias</p>	62S3010149 10 1/4x9	58100-96371-019	3	Fijo
		62S30101410 10 1/4x10	58100-96410-019	3	
		62S30101411 10 1/4x11	58100-96420-019	3	
		62S30101412 10 1/4x12	58100-96430-019	3	
		62S30101413 10 1/4x13	58100-96440-019	3	
		62S301011414 10 1/4x14	58100-95D00-019	3	
		62S30101415 10 1/4x15	58100-96460-019	3	
		C	 <p>35 - 65 hp 3-1/4" Caja de engranajes</p> <ul style="list-style-type: none"> • DT 35C 1987-1989 • DT 40 1983-1998 • DF 40 (4 tiempos) 1999-2010 • DF 40A (4 tiempos) 2010 y posteriores • DT 50, 50M 1983-1984 • DF 50 (4 tiempos) 1999-2010 • DF 50A (4 tiempos, no 50AV) 2010 y posteriores • DT 55 1985-1997 • DT 60 1983-1984 • DF 60A (4 tiempos, no 60AV) 2010 y posteriores • DT 65 1985-1997 <p>Para motores Johnson/Evinrude:</p> <ul style="list-style-type: none"> • 40hp (4 tiempos) 1999 y posteriores • 50hp (4 tiempos) 1999 y posteriores <p>Escape a través del núcleo, 13 estrias</p>	62S40111211 11 1/2x11	
62S40111212 11 1/2x12	58100-95393-019			3	
62S40111213 11 1/2x13	58100-94313-019			3	
62S40111214 11 1/2x14	58100-95353-019			3	
62S40111415 11 1/4x15	58100-95363-019			3	
62S40111816 11 1/8x16	58100-88L71-019			3	
62S401117 11x17	58100-88L81-019			3	
62U4012149 12 1/4x9				3	Interc. 62BHSJC
62U40113410 11 3/4x10				3	
62U40115811 11 5/8x11				3	
62U40113812 11 3/8x12				3	
62U40111813 11 1/8x13				3	
62U40111414 11 1/4x14				3	
624U40105812 10 5/8x12	48-8M8026625			4	
624U40103813 10 3/8x13	48-8M8026630			4	
624U40101814 10 1/8x14	48-8M8026635			4	
624U40101815 10 1/8x15	48-8M8026640	4			

Tipo	Modelo Fueraborda	Referencia-Diam./Paso	Ref. original	Palas	Núcleo
D	 <p>60 - 140 hp 4-1/4" Caja de engranajes</p> <ul style="list-style-type: none"> • DF 60 (4 tiempos) 1998-2009 • DF 70 (4 tiempos) 1998-2008 • DT 75 1983-1997 • DT 85 1979-2000 • DT 90 1989-1997 • DT 100 1989-2000 • DT 115 1981-2001 • DT 140 1981-2001 <p>Escape a través del núcleo, 13 estrias</p>	62S60131215 13 1/2x15	58100-94500-019	3	Fijo
		62S60131417 13 1/4x17	58100-94512-019	3	
D	 <p>50 - 140 hp - 4 tiempos 4-1/4" Caja de engranajes</p> <ul style="list-style-type: none"> • DF 50AV (4 tiempos) 2015 y posteriores • DF 60AV (4 tiempos) 2015 y posteriores • DF 70A (4 tiempos) 2009 y posteriores • DF 80A (4 tiempos) 2009 y posteriores • DF 90 (4 tiempos) 2001-2008 • DF 90A (4 tiempos) 2009 y posteriores • DF 100 (4 tiempos) 2009 y posteriores • DF 115 (4 tiempos) 2001-2012 • DF 115A (4 tiempos) 2013 y posteriores • DF 140 (4 tiempos) 2002-2012 • DF 140A (4 tiempos) 2013 y posteriores <p>Escape a través del núcleo, 15 estrias</p>	62S901415 14x15	58100-90J41-019	3	Fijo
		62S901417 14x17	58100-90J01-019	3	
		62S901418 14x18		3	
		62S901419 14x19	58100-90J11-019	3	
		62S901421 14x21	58100-90J21-019	3	
E	   <p>150 - 300 hp 4-3/4" Caja de engranajes</p> <ul style="list-style-type: none"> • DT 150 1986-2003 • DF 150 (4 tiempos) 2006 y post. • DF 150TG 2014 y posteriores • DT 175 1987 - 1992 • DF 175 (4 tiempos) 2006 y post. • DF 175TG 2014 y posteriores • DT 200 1986-2000 • DT 225 1986 - 2003 • DF 200 (4 tiempos) 2004 y post. • DF 200A (4 tiempos) 2015 y post. • DF 200AP (4 tiempos) 2015 y post. • DF 225 (4 tiempos) 2004 y post. • DF 250 (4 tiempos) 2004 y post. • DF 250AP (4 tiempos) 2014 y post. • DF 300 (4 tiempos) 2007 y post. • DF 300AP (4 tiempos) 2014 y post. <p>Escape a través del núcleo, 15 estrias</p> <p>- Las hélices de la serie U son inferiores a las Hélices originales para DF200 ~ DF300. Se recomiendan las hélices S150 para DF200 ~ DF300.</p>	62U1501613 16x13	48-78114A45	3	Interc. 62BHSE
		62U150151415 15 1/4x15	48-78116A45	3	
		62U1501616 16x16	48-16440A45	3	
		62U1351517 15x17	48-832828A45	3	
		62U150141219 14 1/2x19	48-832830A45	3	
		62U150141421 14 1/4x21	48-832832A45	3	
		62U1501423 14x23	48-832834A45	3	
		624U1501516 15x16	48-834850A45	4	
		624U150141218 14 1/2x18	48-834852A45	4	
		624U1501420 14x20	48-834854A45	4	
		62S1501620 16x20	99105-00800-20P	3	Fijo
		62S150162112 16x21 1/2	99105-00800-215	3	

Honda número de identificación del modelo

	Fabricante	HP	Año modelo	Long. Eje.	Sistema dirección	Mercado
BF2	BF = Honda	Ej: 2	DX = 1999 DY = 2000 D1 = 2001 D2 = 2002 D3 = 2003 D4 = 2004 D5 = 2005 D6 = 2006 DK0 = 2007-sup	S = 15" L = 20"	H = Agarre acelerador C = Embrague Centrifugo	A = Americano

Ejemplo: BF2D1SCHA = Honda, 2 HP, 2001 Modelo, 15", Embrague centrifugo c/agarre acel, Americano

	Fabricante	Caract. Especiales	HP	Año Modelo	Long. eje	Sistema dirección	Arranque	Mercado
BF5-BF20	BF = Honda	P = High Thrust Propeller = Standard Propeller	Ej: 5 20	D1 = 2001 D2 = 2002 D3 = 2003 D4 = 2004 D5 = 2005 D6 = 2006 DK0 = 2007-sup	S = 15" L = 20" XL = 25"	H = Arranque Acelerador C = Embrague centrifugo	S = Electric = Manual T = Electric w/ Power Tilt	A = Americano



EXAMPLE: BFP5D1LHSA = Honda, High Thrust Prop., 5 HP, 2001 Model, 20", Throttle Grip, Elec. Start, American

	Fabricante	HP	Año modelo	Long. Eje	Sistema Dirección	Tilt & Trim	Mercado
BF25-BF225	BF = Honda	Ej: 25 115 225	AX = 1999 AY = 2000 A1 = 2001 A2 = 2002 A3 = 2003 A4 = 2004 A5 = 2005 A6 = 2006 K0 = 2007-sup	S = 15" L = 20" X = 25" XX = 30"	R = Control Remoto H = manual.	T = Tilt & Trim = Manual Tilt J = Jet Drive	A = Americano

Ejemplo: BF25A1LRTA = Honda, 25 HP, 2001 Modelo, 20", Control remoto, Tilt & Trim, America

NOTA: Después del modelo del año 2006 Honda Marine tiene designaciones de año específicas.

		
<p>18-7494 BOBINA Reemplaza: 30520-PNA-007 para: 130/ 135/ 150/ 105 jet/ & 150 HP VTEC 1998-2007</p>	<p>18-23251 BOBINA ENCENDIDO Reemplaza: 30520-PWC-003 Para: BF75(2007 & Sup), BF90(2007 & Sup)</p>	<p>Pack. de 10</p> <p>18-5224 18-5224-9① CABLE DE BUJÍA TERMINAL</p>

	
<p>18-5225 KIT CABLE BUJÍAS Kit incluye 25 ft. rollo 7 MM Hypalon cable encendido con núcleo Metálico y asesoramiento de los 3 diferentes acoples finales para motores fueraborda.</p>	<p>18-5226 CABLE ENCENDIDO Conductor metálico 100' Bobina 7mm Hypalon</p>

	
<p>Pack. de 10</p> <p>18-5750 18-5750-9① TAPA BUJÍAS UNIVER- SAL Se suministra completo con conector terminal</p>	<p>18-5752 TAPA BUJÍAS UNIVERSAL (8mm)</p>

① Precio por pack



**18-6475
ALTERNADOR**

Reemplaza: 31630-ZW5-003
Para: BF115 (1999 & sup), BF130 (1999-2004)



**18-6476
ALTERNADOR**

Reemplaza: 31630-ZY6-003
Para: BF135 & BF150 (2004 & Sup)



**18-6409
ALTERNADOR**

Reemplaza: 31630-ZY3-003
Para: BF200 2002-14, BF225 02-14



**18-6433
ARRANQUE FUERABORDA**

Reemplaza: 31200-ZV5-013
Para: 40 H.P. (1999-SUP)



**18-6445
MOTOR DE ARRANQUE**

Reemplaza: Honda 31200-ZW9-802
Para: 8 & 9.9HP (2001 & Sup)



**18-6959
MOTOR DE ARRANQUE**

Reemplaza: 31200-ZY6-003, 31200-ZY9-003,
31200-ZY9A-0031
Para: 75-150HP 2004-2010



**18-15061
MOTOR ARRANQUE FUERABORDA**

Reemplaza: 31200-ZW1-004
Para: BF75-90(1997-06)



**18-6258
MOTOR TILT/TRIM**

Reemplaza: 36120-ZV5-821
Para: BF35,BF40,BF45,BF50 (1992-2002)



**18-6793
MOTOR TRIM**

Reemplaza: 36120-ZV5-822
Para: 40,50 H.P. (2002-03)



**18-6742
MOTOR TRIM**

Reemplaza: 36120-ZY3-023
Para: 200-225 HP (02-Sup), 175 HP (07-Sup)



**18-6743
MOTOR TRIM**

Reemplaza: 36120-ZY9-003
Para: 75-90 HP (07-Sup)



**18-6745
MOTOR TRIM**

Reemplaza: 36120-ZY6-013
Para: 135-150 HP (04-Sup), 115 HP (07-Sup)



**18-6823
CABLEADO**

Reemplaza: Universal
Convierte 3-Cables Tilt y Trim motores
2-Cable diseño



SEPARADOR AGUA COMBUSTIBLE



Sierra ofrece una línea completa de 10 y 21 micrones filtros de separación de agua incluyendo cazoleta de drenaje filtros para proteger el motor de inyección de combustible y el carburador

Separadores de agua y combustible de Sierra quitan más del 99,8% de agua emulsionada de la gasolina. Sierra de filtros de 10 micras son más de un 90% de eficiencia en la eliminación de partículas tan pequeñas como 10 micrones. Todos los filtros de flujo 90 @ GPH para alimentar el motor que más consumen. Sierra filtros de 10 micrones se recomiendan para evitar daños sensibles al interior y exterior de los sistemas de inyección de combustible.

Sierra #	Honda #	Descripción
18-7947	17670-ZW1-030GH	Filtro y decantador
18-7948	17670-ZW1-801AH	Filtro y decantador
18-7720	16900-SR3-004	Filtro combustible
18-7786	16900-SA5-004	Kit filtro combustible
18-7785	16010-ST5-993	kit filtro combustible

ENSAMBLAJE DE LINEA DE COMBUSTIBLE

18-81042EP-1 **SILVERADO 4000 Premium** OE# 17700-ZW9-010
17700-ZW9-020

Sin conectores

112356 - 8 mm.

112357 - 8 mm.

112351 - 7 mm.

112355 - 7 mm.

Longitud: 2 mts

Longitud: 3 mts

Longitud: 2 mts

Longitud: 3 mts



*



112322
TANQUE
CONECTOR
(SE VENDE SEPARADO)



112325
CONECTOR
COMBUSTIBLE

18-8005S
BOMBA
COMBUSTIBLE

18-80403
CONECTOR
COMBUSTIBLE



*

COMPONENTES DE ENSAMBLAJE LÍNEA DE COMBUSTIBLE

Aplicación bomba Honda: 8, 9.9, 15, 25, 30, 40, 50, 75, 90, 115, 130 HP (2001-02)

* Tanques y motores sólo a modo ilustrativo.







Display
Package



18-8002S 1/4"
1/4" (7 mm.)



112350 (8 mm.)
18-8004 5/16"
BOMBA COMB.
5/16" (8 mm.)
bomba gran capacidad

18-8005S 3/8"
112352 (8-10 mm.)
BOMBA COMB.
3/8" (10 mm.)
Reemplaza: 174512
bomba gran capacidad

 <p>18-25201 SENSOR Reemplaza: 37510-PNB-003 Para: BF5(2007 Y Sup), BF135 (2004 Y Sup), BF150 (2004 Y Sup)</p>	 <p>18-7658 SENSOR OXIGENO Reemplaza: 35655-ZY9-003</p>	 <p>18-7659 SENSOR OXIGENO Reemplaza: 35668-ZY6-003</p>	 <p>NEW</p> <p>18-32153 SENSOR OXIGENO Reemplaza: 35655-ZY3-C01, 35655-ZZ5-004 Para: BF40D, BF50D, BF250A (1997 & ant), BF40DK2, BF50DK2, BF225AK1, BF225AK2 (2007 & sup)</p>
--	---	--	--

 <p>18-25200 ARBOL DE LEVAS SENSOR Reemplaza: 37500-PNB-003 Para: 75 hp MFI</p>	 <p>18-7552 SENSOR, MAP Reemplaza: 37830-PGK-A01 Para: BF135A 2004-2006, BF135AK0, BF150A 2004-2006, BF150AK0, BF200A 2002-2006, BF200AK0, BF225A 2002-2006, BF225AK0</p>	 <p>18-7558 SENSOR Reemplaza: 30530-PPL-A01 Para: BF135A 2004-2006, BF150 2004-2006</p>
--	--	--

 <p>18-7559 SENSOR Reemplaza: 30530-P8F-A01 Para: BF200A 2002-2006, BF200AK0, BF225 2002-2006, BF225AK0</p>	 <p>18-7050 KIT CARB Reemplaza: Honda Kit 1 Para: BF9.9(2000 & inf), BF15(2002 & inf)</p>	 <p>18-7051 KIT CARB Reemplaza: Honda Kit 2 Para: BF9.9(2001 & Sup), BF15(2003 & Sup)</p>
---	---	---

 <p>18-7052 KIT CARB Reemplaza: Honda Kit 3 Para: BF75(1997 & sup), BF90(1997 & sup)</p>	 <p>18-7053 KIT CARB Reemplaza: Honda Kit 4 Para: BF8(2001 & sup), BF9.9(Todos), BF15(Todos), BF20(2003 & sup), BF25(todos), BF30(todos), BF35(1997), BF40(todos), BF45(1997), BF50(todos), BF75(1997 & sup), BF90(1997 & sup)</p>	 <p>18-7047 VÁLVULA AGUJA Reemplaza: 16011-ZV4-005 Para: BF8(2001 & sup), BF9.9(todos), BF15(todos), BF20(2003 & sup), BF25(todos), BF30(todos), BF35(1997), BF40(todos), BF45(1997), BF50(todos), BF75(1997 & sup), BF90(1997 & sup)</p>
---	---	--

 <p>18-7048 VÁLVULA AGUJA Reemplaza: 16011-881-741 Para: BF5(2003 & inf), BF8(todos), BF75(1997 & inf), BF100(1997 & inf)</p>	 <p>18-3627 TERMOSTATO Reemplaza: 19300-881-761 Para: BF5A1, BF5A2, BF5A3, BF5A4, BF5A5, BF5A6, BF5AH, BF5AK, BF5AK0, BF5AM, BF5AW, BF5AX, BF5AY, BF8A3, BF8A4, BF8A5, BF8A6, BF8AH, BF8AK, BF8AK0, BF8AM, BF8AW, BF8AX, BF8AY, BF9.9AH, BF9.9AM, BF9.9AW, BF9.9AX, BF9.9AY, BF15A1, BF15A2, BF15AH, BF15AK, BF15AM, BF15AW, BF15AX, BF15AY, BF50F, BF75E, BF75F, BF100E, BF100F 52°C</p>	 <p>18-3628 TERMOSTATO Reemplaza: 19300-ZW9-003 Para: BF8D1, BF8D2, BF8D3BF15D3, BF15D4, BF15D5, BF15D6, BF15DK0, BF20D3, BF20D4, BF20D5, BF20D6, BF20DK0, BF25D4, BF25D5, BF25D6, BF25DK0, BF30D4, BF30D5, BF30D6, BF30DK0, BF40A4, BF40A5, BF40A6, BF40AK0, BF40D, BF50A4, BF50A5, BF50A6, BF50AK0, BF50D, BF60A, BFP60A, BF75DK0, BF90DK0, BF200A2, BF225A2 60°C</p>
--	--	--

**18-3630
TERMOSTATO**



Reemplaza: 19300-ZV5-043
Para: BF25A, BF25A1, BF25A2, BF25A3, BF25AW, BF25AX, BF25AY, BF30A, BF30A1, BF30A2, BF30A3, BF30AW, BF30AX, BF30AY, BF35AM, BF40A, BF40A1, BF40A2, BF40A3, BF40AW, BF40AX, BF40AY, BF45AM, BF50A, BF50A1, BF50A2, BF50A3, BF50AW, BF50AX, BF50AY, BF75A1, BF75A2, BF75A3, BF75A4, BF75A6, BF75AT, BF75AW, BF75AX, BF75AY, BF90A1, BF115A1, BF115A2, BF115AX, BF115AY, BF130A1, BF130A2, BF130AX, BF130AY 72°C

**18-3031
IMPULSOR**



Reemplaza: 19210-ZY3-003
Para: BF200 & BF225 (2002 & sup)

**18-3100
IMPULSOR**



Reemplaza: 19210-ZW9-013,
19210-ZW9-003
Para: BF8D/9.9D eje corto y largo



**18-3056 CEF
18-3056S
IMPULSOR**

Reemplaza: 19210-ZW1-003
Para: 75-90 HP



**18-3245 CEF
18-3245S
IMPULSOR**

Reemplaza: 19210-881-A01,
19210-881-A02, 19210-ZW9-A02
Para: 5, 7.5, 8, 10 HP



**18-32455
IMPULSOR**

Reemplaza: 19210-ZW9-A32,
19210-ZW9-A31
Para: Honda 8 & 9.9 (2001 & sup);
Honda 15 & 20 (2003 & sup)



**18-3246
IMPULSOR**

Reemplaza: 19210-ZV4-013,
19210-ZV4-651
Para: BF9.9, BF15, AH, AK, AM, AW
Series # 14ZV40M



**18-3247
IMPULSOR**

Reemplaza: 19210-ZV4-651
Para: 8, 9.9, 15 HP



**18-3248 CEF
18-3248S
IMPULSOR**

Reemplaza: 19210-ZV5-003
Para: 35, 40, 45, 50 HP



**18-3249
IMPULSOR**

Reemplaza: 19210-ZV7-003
Para: 25, 30 HP



**18-3250
IMPULSOR**

Reemplaza: 19210-ZW1-B04
Para: 75, 90, 115, 130 HP



**18-3268
LLAVE IMPULSOR**

Reemplaza: 90752-ZV4-650
Para: BF9.9A, BF15A



**18-3269
LLAVE IMPULSOR**

Reemplaza: 90752-ZV7-000
Para: BF25, BF30



**18-3270
LLAVE IMPULSOR**

Reemplaza: 90752-ZV5-003
Para: BF35, BF40, BF45, BF50



**18-3271
LLAVE IMPULSOR**

Reemplaza: 90752-ZW1-B02
Para: BF75-BF90 AX & sup, BF115,
BF130

APLICACIONES PARA MOTORES EN LA PÁGINA 369



18-3273
LLAVE IMPULSOR
Reemplaza:
90752-ZY3-003
Para: BF200, BF225



18-3122
PLATINA IMPULSOR
Reemplaza:
19231-ZW1-003
Para: 75-90 HP

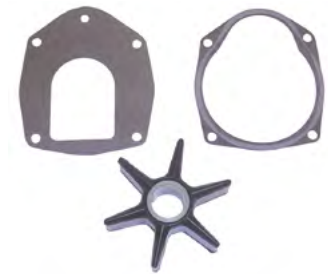

18-3187
KIT REPARACIÓN IMPULSOR
Reemplaza: 06192-ZW1-305
Para: BF75-90, (1996-98)
Incluye impulsor 18-3056

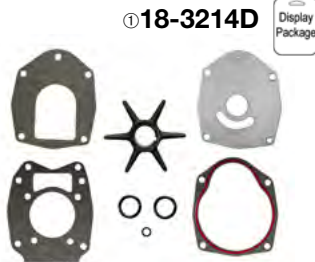

18-3214
KIT BOMBA AGUA
Reemplaza: 19021-ZW1-003
Para: BF 70/BF 90 1996-98
Incluye impulsor 18-3056



18-3278
KIT SERVICIO BOMBA AGUA
Reemplaza: 06192-ZV1-C00
Para: BF5
Incluye impulsor 18-3245



18-3279
KIT SERVICIO BOMBA DE AGUA
Reemplaza: 06192-881-C00
Para: BF8A (USA)
Incluye impulsor 18-3245



18-3280
KIT SERVICIO BOMBA DE AGUA
Reemplaza: 06192-ZV4-000
Para: BF9.9A/BF15A
Incluye impulsor 18-3247

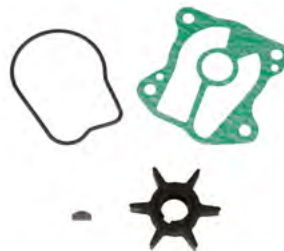

18-3281
KIT SERVICIO BOMBA DE AGUA
Reemplaza: 06192-ZV7-000
Para: BF25/30
Incluye impulsor 18-3249



18-3282
KIT SERVICIO BOMBA DE AGUA
Reemplaza: 06192-ZV5-003
Para: BF35/45, BF40/50
Incluye impulsor 18-3248

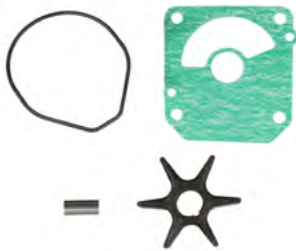

18-3283
KIT SERVICIO BOMBA DE AGUA
Reemplaza: 06192-ZW1-000
Para: BF115/130, BF75/90 AX & despues
Incluye impulsor 18-3250



18-3284
KIT SERVICIO BOMBA DE AGUA
Reemplaza: 06192-ZY6-000
Para: BF135 / BF150
Incluye impulsor 18-3250

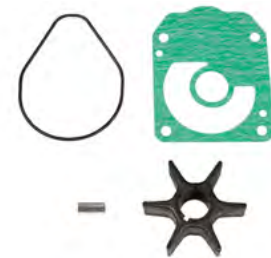

18-3285
KIT SERVICIO BOMBA DE AGUA
Reemplaza: 06192-ZY3-000
Para: BF200/225
Incluye impulsor 18-3031



18-3478
KIT REPARACION BOMBA AGUA
Reemplaza: 06192-ZW9-A30
Para: BFP8D/BFP9.9D (2003-06), BF15D/
BF20D (2003-06), BFP20D(2004-06), BFP8D/
BFP9.9D/BF15D/BF20D (K0, K2, K3), BFP20D
(K0)



18-3489
KIT REPARACION BOMBA AGUA
Reemplaza: 06192-ZX2-C00
Para: BF250A (TODOS)



18-3492
KIT REPARACION BOMBA AGUA
Reemplaza: 06192-ZW1-B04
Para: BF75A/BF90A/BF115A/BF130A (1999-02)

① Referencias acabadas en "D" envasadas - referencia normal no envasada



18-3493
KIT REPARACION BOMBA AGUA
 Reemplaza: 06192-ZW9-000
 Para: BF8D/BFP8D/BF9.9D (2002-06), BF8D/
 BF9.9D/BFP9.9D(K0, K2, K3)



18-4536
KIT REPARACION BOMBA AGUA
 Reemplaza: 006192-ZV4-A00
 Para: BF9.9A/15A (1998-01)



18-2495
JUNTA BOMBA DE AGUA
 Reemplaza: 19232-ZV4-610
 Para: BF9.9A, BF15A



18-2496
JUNTA BOMBA DE AGUA
 Reemplaza: 19233-ZV5-000
 Para: BF25, BF30



18-2499
JUNTA BOMBA DE AGUA
 Reemplaza: 19234-ZY3-000
 Para: BF200, BF225













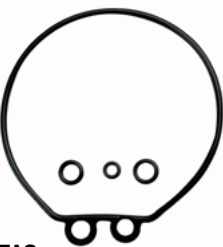
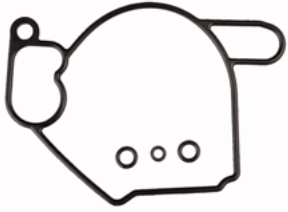
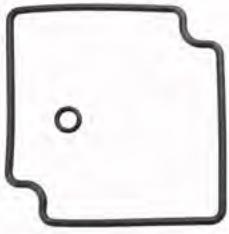

APLICACIÓN DEL KIT DE REPARACIÓN DE BOMBA DE AGUA - HONDA 4 TIEMPOS

MODEL	HP	AÑO	CODIGO HONDA	IMPULSOR	JUNTAS	KIT SIN CARCASA
BF5A	5	1998-06	6315899	18-3245	18-2524	18-3278
BF5A	5	K0, K2, K3	6315899	18-3245	18-2542	18-3278
BF8A	8	1998-00	6315386	18-3245	18-2608	18-3279
BF8A	8	2003-06	6315386	18-3245	18-2608 18-2609	18-3279
BF8A	8	K0	6315386	18-3245	18-2608 18-2610	18-3280
BF8D	8	2002-06	7452345	18-3100	18-99153	18-3493
BF8D	8	K0, K2, K3	7452345	18-3100	18-99153	18-3493
BFP8D	8	2002-06	7452345	18-3100	18-99153	18-3493
BFP8D	8	2002-06	7452352	18-32455	18-99153	18-3478
BFP8D	8	K0, K2, K3	7452345	18-3100	18-99153	18-3493
BFP8D	8	K0, K2, K3	7452352	18-32455	18-99153	18-3478
BF9.9A	9.9	1998-01	6310494	18-3247	18-2495	18-4536
BF9.9A	9.9	1999-02	7452360	18-3247	18-2495	18-3280
BF9.9D	9.9	2002-06	7452345	18-3100	18-99153	18-3493
BF9.9D	9.9	K0, K2, K3	7452345	18-3100	18-99153	18-3493
BFP9.9D	9.9	2002-06	7452345	18-3100	18-99152	18-3493
BFP9.9D	9.9	2002-06	7452352	18-32455	18-99153	18-3478
BFP9.9D	9.9	K0, K2, K3	7452345	18-3100	18-99153	18-3493
BFP9.9D	9.9	K0, K2, K3	7452352	18-32455	18-99153	18-3478
BF15A	15	1998-01	6310494	18-3247	18-2495	18-4536
BF15A	15	1999-02	7452360	18-3247	18-2495	18-3280
BF15D	15	2003-06	7452352	18-32455	18-99153	18-3478
BF15D	15	K0, K2, K3	7452352	18-32455	18-99153	18-3478
BFP15D	15	K0, K2, K3	7452352	18-32455	18-99153	18-3478
BF20D	20	2003-06	7452352	18-32455	18-99153	18-3478
BF20D	20	K0, K2, K3	7452352	18-32455	18-99153	18-3478
BFP20D	20	2004-06	7452352	18-32455	18-99153	18-3478

APLICACIÓN DEL KIT DE REPARACIÓN DE BOMBA DE AGUA - HONDA 4 TIEMPOS

MODEL	HP	AÑO	CODIGO HONDA	IMPULSOR	JUNTAS	KIT SIN CARCASA
BFP20D	20	K0	7452352	18-32455	18-99153	18-3478
BF25A	25	2001-03	7452378	18-3249	18-2496	18-3281
BF25D	25	2004-06	7452378	18-3249	18-2496	18-3281
BF25D	25	K0, K2, K3	7452378	18-3249	18-2496	18-3281
BF30A	30	2001-03	7452378	18-3249	18-2496	18-3281
BF30D	30	2004-06	7452378	18-3249	18-2496	18-3281
BF30D	30	K0, K2, K3	7452378	18-3249	18-2496	18-3281
BF40A	40	2000-06	7452386	18-3248	18-2496 18-0176	18-3281
BF40A	40	K0	7452386	18-3248	18-2496 18-0176	18-3281
BF40D	40	K2	7452386	18-3248	18-2496 18-0176	18-3281
BF40D	40	Pre-1997	7452386	18-3248	18-2496 18-0176	18-3281
BF50A	50	2000-06	7452386	18-3248	18-2496 18-0176	18-3281
BF50A	50	K0	7452386	18-3248	18-2496 18-0176	18-3281
BF50D	50	K2	7452386	18-3248	18-2496 18-0176	18-3281
BF50D	50	Pre-1997	7452386	18-3248	18-2496 18-0176	18-3281
BF75A	75	1997-98	4921441	18-3056	18-2565	18-3214
BF75A	75	1999-02	6706634			18-3492
BF75A	75	2003-06	7452394	18-3250	NSS	18-3283
BF75D	75	K0, K2	7452394	18-3250	NSS	18-3283
BF90A	90	1997-98	4921441	18-3056	18-2565	18-3214
BF90A	90	1999-02	6706634			18-3492
BF90A	90	2003-06	7452394	18-3250	NSS	18-3283
BF90D	90	K0, K2	7452394	18-3250	NSS	18-3283
BF115A	115	1999-02	6706634			18-3492
BF115A	115	2003-06	7452394	18-3250	NSS	18-3283
BF115A	115	K0	7452394	18-3250	NSS	18-3283
BF115D	115	K1	7632797	18-3250	18-2497	18-3284
BF115D	115	Pre-1997	7631797	18-3250	18-2497	18-3284
BF130A	130	1999-02	6706634			18-3492
BF130A	130	2003-04	7452394	18-3250	NSS	18-3283
BF135A	135	2004-06	7632797	18-3250	18-2497	18-3284
BF135A	135	K0, K2	7632797	18-3250	18-2497	18-3284
BF150A	150	2004-06	7632797	18-3250	18-2497	18-3284
BF150A	150	K0, K2	7632797	18-3250	18-2497	18-3284
BF175A	175	K1	7452402	18-3031	18-2499 18-8299	18-3285
B175A	175	K2	7452402	18-3031	18-2499 18-8299	18-3285
BF200A	200	2002-06	7452402	18-3031	18-2499 18-8299	18-3285
BF200A	200	K0, K1, K2	7452402	18-3031	18-2499 18-8299	18-3285
BF225A	225	2002-06	7452402	18-3031	18-2499 18-8299	18-3285
BF225A	225	K0, K1, K2	7452402	18-3031	18-2499 18-8299	18-3285
BF250A	250	TODOS		18-3031	18-99154	18-3489

 <p>18-2524 JUNTA BOMBA AGUA Reemplaza: 19232-ZV1-A10 Para: BF5</p>	 <p>18-2608 JUNTA BOMBA AGUA Reemplaza: 19232-881-850 Para: BF8A</p>	 <p>18-2609 JUNTA BOMBA AGUA Reemplaza: 19234-881-850 Para: BF8A</p>
 <p>18-0176 JUNTA BOMBA AGUA Reemplaza: 19242-ZV5-000</p>	<p>Pack. de 2</p>  <p>18-2563 18-2563-9 ① JUNTA IMPULSOR Reemplaza: 19232-ZW1-003</p>	<p>Pack. de 2</p>  <p>18-2564 18-2564-9 ① JUNTA IMPULSOR Reemplaza: 19234-ZW1-003</p>
<p>Pack. de 2</p>  <p>18-2565 18-2565-9 ① JUNTA IMPULSOR Reemplaza: 19242-ZW1-003</p>	 <p>18-2480 CONJUNTO JUNTAS Reemplaza: 16010-ZV4-005 Para: BF8(2001), BF9.9(2001 & inf), BF15(2002 & inf), BF25(todos), BF30(todos), BF35(1997), BF40(todos), BF45(1997), BF50(todos), BF75(1997-06), BF90(1997-06)</p>	 <p>18-2481 CONJUNTO JUNTAS Reemplaza: 16010-ZW9-003 Para: BF8(2002 & sup), BF9.9(2002 & sup), BF15(2003 & sup), BF20(2003 & sup)</p>
 <p>18-2482 CONJUNTO JUNTAS Reemplaza: 16010-881-003 Para: BF5(2003 & inf), BF8(2000 & inf, 2003 & sup), BF50(1996 & inf), BF75(1996 & inf), BF100(1996 & inf)</p>	 <p>18-2470 JUNTA MONTAJE CARB. Reemplaza: 16221-ZV4-610 Para: BF9.9 (2000 & inf), BF15 (2002 & inf)</p>	 <p>18-2471 JUNTA MONTAJE CARB Reemplaza: 16221-ZW9-000 BF8(2001 & Sup), BF9.9(2001 & Sup)</p>
 <p>18-2472 JUNTA CARB MONTAJE Reemplaza: 16221-ZW1-000 Para: BF75(1997-06), BF90(1997-06)</p>	 <p>18-2473 JUNTA MONTAJE CARB. Reemplaza: 16201-881-850 Para: BF8(2000 & inf, 2003 & sup), BF75(1996 & inf), BF100(1996 & inf)</p>	<p>Pack. de 2</p>  <p>18-2945 18-2945-9 ① 18-29451-9 ① (Pack. de 50) JUNTA TORNILLO DRENAJE Use con 18-2244 tornillo drenaje</p>

 <p>18-0300 JUNTA COLECTOR AD- MISIÓN Reemplaza: 17105-ZY6-000 Para: BF135-BF150</p>	 <p>18-0390 JUNTA COLECTOR AD- MISIÓN Reemplaza: 17105-ZY3-004 Para: BF200-BF225 (2002 y SUP)</p>	 <p>18-0248 JUNTA COLECTOR ADMIS- IÓN Reemplaza: 17151-ZW5-000</p>
 <p>18-0382 JUNTA CUERPO ACELERADOR Reemplaza: 17109-ZY6-000 Para: BF75-BF150</p>	 <p>18-0396 JUNTA CUERPO ACELERADOR Reemplaza: 17109-ZY3-004 Para: BF200-BF225 (2002 & SUP)</p>	 <p>18-0737 JUNTA CUERPO ACELERADOR Reemplaza: 16176-POA-004</p>
 <p>18-3288 RETÉN Reemplaza: 91252-ZV1-003 Para: BF5</p>	 <p>18-8298 RETÉN Reemplaza: 91252-935-004 Para: BF8A</p>	 <p>18-8299 RETÉN DE GOMA Reemplaza: 91356-ZY3-003 Para: BF200, BF225</p>
 <p>18-1156 COJINETE MARCHA ADELANTE Reemplaza: 91051-ZW1-003</p>	 <p>18-1157 COJINETE AGUJAS MARCHA ADELANTE Reemplaza: 91057-ZW1-003</p>	 <p>18-1158 COJINETE AGUJAS Reemplaza: 91053-ZW1-003</p>
 <p>18-7909  187909E Easterner FILTRO ACEITE Reemplaza: 15400-POH-305PE, 15400-POH-305, 15400-ZJI-004, 15400-PLM-A01PE (Aplicación en la siguiente página)</p>	 <p>18-7913  187913E Easterner FILTRO ACEITE Reemplaza: 15400-PFB-014 (Aplicación en la siguiente página)</p>	 <p>18-7911-1  1879111 Easterner FILTRO ACEITE Reemplaza: 15400-PFB-007 (Aplicación en la siguiente página)</p>

Modelos	AÑO	SS Num.	Reemplaza	Ref No.	Modelos	AÑO	SS Num.	Reemplaza	Ref No.
BF8D, BFP8D	2001-Actual	15400-PFB-004	15400-PFB-014	18-7913	BF50A	1998-Ant.	15400-PJ7-005	15400-PFB-014	18-7913
BF9D, BFP9D	2001-Actual	15400-PM3-004	15400-PFB-014	18-7913	BF25	1999-2005	15400-ZW4-003	15400-PFB-007	18-7911-1
BF15D, BFP15D	2003-Actual	15400-PM3-405	15400-PFB-014	18-7913	BF30	1999-2005	15400-ZW4-003	15400-PFB-007	18-7911-1
BF20D	2003-Actual	15400-PJ7-015	15400-PFB-014	18-7913	BF40	1999-2005	15400-ZW4-003	15400-PFB-007	18-7911-1
BF25A	1998-Ant.	15400-PJ7-005	15400-PFB-014	18-7913	BF50	1999-2005	15400-ZW4-003	15400-PFB-007	18-7911-1
BF30A	1998-Ant.	15400-PJ7-005	15400-PFB-014	18-7913	BF75, BF90	1997-Actual	15400-POH-305PE	15400-PLM-A01PE	18-7909
BF35AM	1998-Ant.	15400-PJ7-005	15400-PFB-014	18-7913	BF115, BF130	1999-Actual	15400-POH-305	15400-PLM-A01PE	18-7909
BF40A	1998-Ant.	15400-PJ7-005	15400-PFB-014	18-7913	BF135, BF150	2004-Actual	15400-ZJ1-004	15400-PLM-A01PE	18-7909
BF45AM	1998-Ant.	15400-PJ7-005	15400-PFB-014	18-7913	BF200, BF225	2002-Actual	15400-ZJ1-999AH	15400-PLM-A01PE	18-7909

**Zinc sólo para agua salada
Magnesio es para agua dulce
El aluminio es de agua salobre, o si el barco se utiliza tanto en los entornos de dulce y salada**

 <p>18-2448 KIT DRENAJE/LLENADO UNIDAD INF. • M8 - 1.25 rosca Para: Yamaha, Nissan/Tohatsu, & Honda unidad inferior</p>	 <p>① 603048 Alu. ③ 009464 Zinc ANODO Reemplaza: 41109-ZW1-003 BF75-BF90 (1997-98)</p>	 <p>① 603041 Alu. ② 18-6241 Mag. ③ 009354 Zinc ANODO Reemplaza: 41107-ZW1-003ZA BF75-BF90 (1997-98)</p>
 <p>① 603114 Alu. ③ 009114 Zinc ANODO, TRIM Reemplaza: 41107-ZV5-00-00 Para: BF25, BF30, BF35, BF45, BF50 (1997-Sup)</p>	 <p>① 603113 Alu. ANODO Reemplaza: 41106-935-812.</p>	 <p>③ 009322 Zinc ANODO</p>
 <p>③ 025856 Zinc ANODO</p>	 <p>③ 025440 Zinc ANODO Reemplaza: 06411-ZV5-000</p>	 <p>③ 025418 Zinc ANODO Reemplaza: 41109-ZW1-003</p>

① Aluminio ② Magnesio ③ Zinc ④ Precio por pack
⑤ Referencias acaban en "D" envasadas - referencia normal no envasada



③ 025392 Zinc
ANODO
Reemplaza: 12155-ZV4-A00



③ 025393 Zinc
ANODO
Reemplaza: 41106-ZW9

Pack. de 10



18-3200
18-3200-9 ④
ARANDELA SUJECIÓN
Reemplaza: 90508-ZW1-003
Para: 75-90 HP



⑤ 18-3701D



18-3701
KIT DE TUERCAS

— CONTIENE —

Ref #	O.E. #	Descripción
18-3200	90508-ZW1-003	Arandela suj.
18-3700	90301-ZW1-003	Tuercas



18-79989
STICKS ARRASTRE

Para: Mayoría fuerabordas 150hp con tilt/trim integral.



18-8362-1
KIT INFERIOR SELLADO
Para: Series 14ZV50M



18-8363
KIT INFERIOR SELLADO

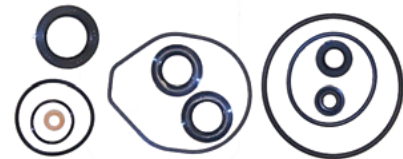

18-8365
KIT INFERIOR SELLADO

Pack. de 5



18-7198
18-7198-9④
ARO
Reemplaza: 91353-ZW1-003



RETENES ACEITE

Ref No.	Descripción	O.E. No.
18-0522	EJE TRANSM	91254-ZW1-003
18-0583	EJE TRANSM	91251-ZW1-003
18-2002	EJE HÉLICE	91252-ZW1-003
18-2053	EJE HÉLICE	91255-ZW1-003
18-2054	EJE TRANSM	91253-ZW1-003

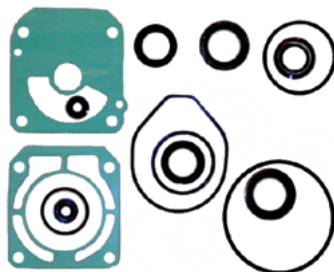

18-8366
KIT SELLADO UNIDAD INF.

APLICACIÓN DEL KIT DE SELLADO DE UNIDAD INFERIOR

HP/Modelo	Ref #
BF9.9, BF15	18-8363
BF35AM, BF45AM, BF40A, BF40AW, BF40AX, BF50A, BF50AW, BF50AX	18-8362-1
BF75, BF90	18-8366
BF115, BF130	18-8365

④ Precio por pack

⑤ Referencias acabas en "D" envasadas - referencia normal no envasada



HONDA

POTENCIA HP	AÑO	NGK	REF.PRONAUTIC	POTENCIA HP	AÑO	NGK	REF.PRONAUTIC
BF 2B 4T		CR5HSB	050605	BF 25/A 4T	1993+	DR7EA	050824
BF 2D 4T	1999+	CR5HSB	050605	BF 25B 4T		DR7EA	050824
BF 2/A 4T	1984+	BMR4A	050841	BF 25D4 4T	2004+	DR7EA	050824
BF 2B 4T		CR5HSB	050605	BF 28 4T		CR5HSB	050605
BF2.3 4T		CR5HSB	050605	BF 28D 4T		CR5HSB	050605
BF 4.5B 4T		BPR5ES	050825	BF 30/A 4T	1994+	DR7EA	050824
BF 5AK		BPR5ES	050825	BF 30D4 4T	2004+	DR7EA	050824
BF 5 4T	1984+	BPR5ES	050825	BF 35/A 4T	1990+	DR7EA	050824
BF 5A 4T		BPR5ES	050825	BF 40B 4T		DR7EA	050824
BF 6B 4T	2003+	DR4HS	050725	BF 40/A 4T	1994+	DR7EA	050824
BF6 4T		DR4HS	050725	BF 45/A 4T	1990+	DR7EA	050824
BF6CH 4T	2004+	CR5EH-9	050890	BF 50/F 4T	1985-1994	BPR5ES	050825
BF 7,5 4T	1977+	DR5HS	050852	BF 50 4T	1986-1994	BPR5ES	050825
BF 8 4T	2001+	CR5EH-9	050890	BF 50/A 4T	1994+	DR7EA	050824
BF 8D 4T		CR5EH-9	050890	BF 70A 4T		DR7EA	050824
BF 8D1 8.0HP 4T	2001+	CR5EH-9	050890	BF 75 4T	2003+	DR7EA	050824
BF 8 4T	1987-2000	DR5HS	050852	BF 75B 4T		DR7EA	050824
BF 8 A/B/C 4T	1990-2000	DR5HS	050852	BF 75E 4T		DR5HS	050852
BF 8B1 4T		CR5EH-9	050890	BF 75A 4T	1995+	DR7EA	050824
BF 9/A 4T		DR5HS	050852	BF 75 4T		DR5HS	050852
BF 9.9 4T	1987-2001	DR5HS	050852	BF 90/A 4T	1995+	DR7EA	050824
BF 9.9 A/B 4T		DR5HS	050852	BF 100E 4T		DR5HS	050852
BF 9.9D1 9.9HP 4T	2001+	CR5EH-9	050890	BF 100 4T		DR5HS	050852
BF 10D 4T	2001+	CR5EH-9	050890	BF 115/A 4T	1998+	DR5HS	050852
BF 10/B1 4T	2001+	CR5EH-9	050890	BF 130A 4T	1998+	DR5HS	050852
BF 15D 4T	2003+	CR5EH-9	050890	BF 135A 4T		IZFR6K11	050726
BF 15B 4T		DR5HS	050852	BF 150A 4T		IZFR6K11	050726
BF 15 4T	1987-1990	DR6HS	050851	BF 175A 4T		IZFR6K11	050726
BF 15A 4T	1996-2002	DR5HS	050852	BF 200A V6	2002+	IZFR6K11	050726
BF 20 4T	1993+	DR7EA	050824	BF 225A V6	2002+	IZFR6K11	050726
BF 20/F 4T	1985+	BMR4A	050841				
BF 20D 4T	2003+	CR5EH-9	050890				

**HONDA**

POTENCIA HP	CHAMPION	REF.PRONAUTIC
2HP BF2A,D	CJ14	050986
5HP OHC 4 T BF5A	RN11YC4	050970
7.5HP B75	P10Y	050958
8.0HP OHC 4 T BF8A	P10Y	050958
9.9HP BF9.9A	P10Y	050958
15HP OHC 4 T BF15A	P8Y	050964
20HP BF20A	RA6HC	050987
25HP OHC 4 T BF25A	RA8HC	050957
30HP OHC 4 T BF30A	RA8HC	050957
35HP BF35A	RA8HC	050957
40HP OHC 4 T BF40A	RA8HC	050957
45HP BF45A	RA8HC	050957
50HP OHC 4 T BF50A	RA8HC	050957
70HP OHC 4 T BF70A	RA8HC	050957
75HP BF75A	RA8HC	050957
90HP OHC 4 T BF90A	RA8HC	050957
115HP OHC 4 T	RC9MC4	051026
130HP OHC 4 T	RC9MC4	051026
150HP BF150	RC9MC4	051026
BF200, 225	RC9MC4	051026

TABLA EQUIVALENCIA TURBINA TOHATSU

MOTOR TOHATSU	REFERENCIA TOHATSU	PRONAUTIC
BF8B1 y D, BF9,9D, BF10B y D, BFP8, BFP9,9 y BFP10B	19210-ZW9-003	18-3100
BF8C, BF9,9A y B, BF15 A y B	19210-ZV4-651	18-3247
BF9,9 AH, AK, AM y BF15AH, AK, AK	19210-ZV4-013	18-3246
BF20A, BF25A y D, BF30A y D	19210-ZV7-003	18-3249
BF75 y BF90AT	19210-ZW1-303	18-3056
BF4B, BF5A, BF6B, BF8AH y BX	19210-881-003	18-3245
BF50F, BF75A, B, C, D, E, BF100A A, B, C, D, E, F	19210-881-003	18-3245
BF8B1, BF9,9DK2, BF10DZ, BF15D, BF20D	19210-ZW9-A32	18-32455
BFP8B1, BFP9,9D, BFP10B	19210-ZW9-A32	18-32455
BF35AM, BF45AM, BF40A, BF50A, BF60A	19210-ZV5-003	18-3248
BF175A3 y D, BF200A y D, BF225A y D, BF250Ay D	19210-ZY3-003	18-3031
BF75, BF90, BF115, BF 130	19210-ZW1-B04	18-3250



HÉLICES BAEKSAN

Baeksan fabrica miles de hélices desde el año 1984. Nuestras helices de altas prestaciones fabricadas con los mejores materiales aseguran una larga vida y una navegación tranquila y sin sobresaltos.

Sus palas compensadas ofrecen una reducción significativa de la vibraciones.

Cojinete de goma insertado en el nucleo en versión fija o nucleo intercambiable.

Mano de pintura de alto grosor para evitar la corrosión.

En caso de no conocer la referencia original de la hélice a reemplazar siga los siguientes pasos:

- 1-Comprueba el rango de Revoluciones por minuto (RPM) del fabricante del motor en el manual.
- 2-Comprueba las RPM maximas del motor leyendo el panel para determinar el paso y velocidad optimo.
- 3-Si las RPM maximas exceden el rango recomendado, disminuye las RPM utilizando un paso superior.
- 4-Si las RPM son mas bajas que el rango recomendado, aumenta las RPM utilizando un paso inferior.

Si no localiza la hélice que necesita contacte con nuestro departamento técnico.

Tipo	Modelo Fueraborda	Referencia-Diam./Paso	Ref. original	Palas	Núcleo
A	 <p>8 - 20 hp 2-1/2" Caja de engranajes</p> <ul style="list-style-type: none"> • BF 8 2000 y posteriores • BF 9.9 1988 y posteriores • BF 15 1991 y posteriores • BF 20 2003 y posteriores <p>Escape a través del núcleo, 8 estrias</p>	62H159148 9 1/4x8	58130-ZV4-008AH	3	Fijo
		62H159149 9 1/4x9	58130-ZV4-009AH	3	
		62H159914934 9 1/4x9 3/4		3	
		62H159141012 9 1/4x10 1/2	58130-ZV4-010AH	3	
		62H1591411 9 1/4x11		3	
		62H1591412 9 1/4x12		3	
B	 <p>25 - 30 hp 3" Caja de engranajes</p> <ul style="list-style-type: none"> • BF 25 1994 y posteriores • BF 30 1995 y posteriores <p>Escape a través del núcleo, 10 estrias</p>	62H309789 9 7/8x9	58130-ZV7-009AH	3	Fijo
		62H3097810 9 7/8x10	58130-ZV7-010AH	3	
		62H3097811 9 7/8x11	58130-ZV7-011AH	3	
		62H3097812 9 7/8x12	58130-ZV7-012AH	3	
		62H3097813 9 7/8x13	58130-ZV7-013AH	3	
		62H309781414 9 7/8x14 1/4		3	
C	   <p>35 - 60 hp 3-1/4" Caja de engranajes</p> <ul style="list-style-type: none"> • BF 35 1991-1994 • BF 40 1995 y posteriores • BF 45 1991-1994 • BF 50 / 50A 1995 y posteriores • BF 60 / 60A 2010 y posteriores <p>Escape a través del núcleo, 13 estrias</p>	62H4012149 12 1/4x9	58130-ZV5-009AH	3	Fijo
		62H40113410 11 3/4x10		3	
		62H40115811 11 5/8x11	58130-ZV5-011AH	3	
		62H40113812 11 3/8x12	58130-ZV5-012AH	3	
		62H40111813 11 1/8x13	58130-ZV5-013AH	3	
		62H40111414 11 1/4x14	58130-ZV5-014AH	3	
		62H401115 11x15	58130-ZV5-015AH	3	Interc. 62BHHC
		62U4012149 12 1/4x9		3	
		62U40113410 11 3/4x10		3	
		62U40115811 11 5/8x11		3	
		62U40113812 11 3/8x12		3	
		62U40111813 11 1/8x13		3	
		62U40111414 11 1/4x14		3	
		624U40105812 10 5/8x12	48-8M8026625	4	
		624U40103813 10 3/8x13	48-8M8026630	4	
624U40101814 10 1/8x14	48-8M8026635	4			
624U40101815 10 1/8x15	48-8M8026640	4			

Tipo	Modelos Fueraborda	Referencia-Diam./Paso	Ref. original	Palas	Núcleo	
D	 <p>60 - 130 hp 4-1/4" Caja de engranajes</p> <ul style="list-style-type: none"> • BFP 60 2010 y posteriores • BF 75 1995 y posteriores • BF 90 1995 y posteriores • BF 100 2016 y posteriores • BF 115 1998-2010 • BF 130 1998-2004 <p>Escape a través del núcleo, 15 estrias</p> <p>*Nota</p> <ul style="list-style-type: none"> -Para BF75, BF90hp 1995-1998 usar Mercury núcleo int. (62BHMD). -Para BF75, BF90hp 1999 y posteriores, BFP60, BF115, BF130 1998 y posteriores usar Honda núcleo int. (62BHHD). 	62U601410 14x10	48-854342A45	3	Interc. 62BHHD	
		62U901411 14x11	48-77338A45	3		
		62U901413 14x13	48-77340A45	3		
		62U60133415 13 3/4x15	48-77342A45	3		
		62U90131417 13 1/4x17	48-77344A45	3		
		62U901319 13x19	48-77346A45	3		
		62U90123421 12 3/4x21	48-77348A45	3		
		624U90137811 13 7/8x11	8M8026560	4		
		624U90137813 13 7/8x13	8M8026570	4		
		624U90133815 13 3/8x15	8M8026580	4		
		624U901317 13x17	8M8026590	4		
		624U90121219 12 1/2x19	8M8026600	4		
		62U1501613 16x13	48-78114A45	3		Interc. 62BHHE
		62U150151415 15 1/4x15	48-78116A45	3		
		62U1501616 16x16	48-16440A45	3		
62U1351517 15x17	48-832828A45	3				
62U150141219 14 1/2x19	48-832830A45	3				
62U150141421 14 1/4x21	48-832832A45	3				
62U1501423 14x23	48-832834A45	3				
624U1501516 15x16	48-834850A45	4				
624U150141218 14 1/2x18	48-834852A45	4				
624U1501420 14x20	48-834854A45	4				



BS.PRO aluminum propellers are the crystals of our endeavor.





18-5225
KIT CABLE BUJÍAS
 El kit incluye 7,5 mts de cable de encendido de hypalon de 7mm y un surtido de 3 terminales diferentes para fueraborda..



18-5226
CABLE ENCENDIDO
 Alma metálica
 Bobina 100'
 7mm Hypalon



Pack. de 10
18-5224
18-5224-9①
CABLE TERMINAL ENCENDIDO

Pack. de 10



18-5750
18-5750-9①
TAPA BUJÍAS UNIVERSAL
 Suministrado completo con conector terminal



18-5752
**TAPA BUJÍAS UNI-
 VERSAL**
 8mm



18-5133
BOBINA ENCENDIDO
 Reemplaza: 3A0-06040-1,
 3A0-06048-1
 Para: 2002 y Prior M y NS Modelo 25C2,
 C3, 30A3, A4; 2003 25C3, A4; 2005 25C3



18-5134
CDI
 Reemplaza: 3G2-06060-2
 Para: 2002 y Prior M y NS Modelo 15D2,
 18E, E2, 9.9D, D2; 2003 15D2, 18E2, 9.9D2



18-5143
BOBINA
 Reemplaza: Tohatsu 369-06021-0
 Para: 4C, 5B, 5BS (2003)



18-5165
BOBINA
 Reemplaza: Nissan 3G3-06021-1
 Para: 9.9D(2002 e inferior)9.9D2(2003 e inferior), 15D(2002 e inferior), 15D2(2003 e inferior), 18E(2002 e inferior), 18E2(2003 e inferior)



18-5166
BOBINA ENCENDIDO
 Reemplaza:
 Nissan/Tohatsu 3G2-06040-2 ss
 to 3M3-06048-2
 Para: 9.9D(2002 e inferior)9.9D2(2003 e inferior), 15D(2002 e inferior), 15D2(2003 e inferior), 18E(2002 e inferior),18E2(2003 e inferior)



18-5185
BOBINA ENCENDIDO
 Reemplaza: Tohatsu 3F0-06153-1
 Para: 3.5/4.5HP (1997-2005)

① Precio por pack

NISSAN/TOHATSU APLICACIÓN ENCENDIDO

Modelo	Año inicio	Año final	Bobina encendido	CDI	Bobina
FS8	2003	2014	-	-	-
M15	1997	2002	-	18-5134	18-5165
M15	2003	2003	18-5166	18-5134	18-5165
M18	1997	2003	18-5166	18-5134	18-5165
M2.5	1997	2005	-	-	-
M25	1997	2005	18-5133	-	-
M3.5	1997	2005	-	-	-
M30	1997	2003	18-5133	-	-
M4	2003	2003	-	-	18-5143
M5	2003	2003	-	-	18-5143
M9.9	1997	2003	18-5166	18-5134	18-5165
MFS8	2006	2014	-	-	-
MFS8	2003	2004	-	-	-
MFS9.8	2003	2014	-	-	-
NS2.5	1997	2005	18-5185	-	-
NS3.5	1997	2005	18-5185	-	-
NS15	1997	2002	-	18-5134	-
NS18	1997	2002	-	18-5134	-
NS9.9	1997	2002	-	18-5134	-
NSF8	2004	2004	18-23207	-	-
NSF8	2010	2014	18-23207	-	-
NSF9.8	2005	2005	18-23207	-	-
NSF9.8	2010	2014	18-23207	-	-



18-6823
CABLEADO
Reemplaza: Universal
Convierte motores tilt/trim de 3 a 2 cables.

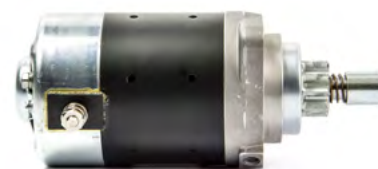

18-6418
MOTOR ARRANQUE
Reemplaza: Tohatsu 353-76010-4
Para: M45A2, M50C, M60A, M70A2, M90A, M140A, NS45A2, NS50C, NS60A, NS70A2, NS90A, NSD90A, NS120A, NS140A
(9 dientes)



18-6430
MOTOR ARRANQUE
Reemplaza: Tohatsu B29A-90500A
Para: 1981-on 2WT60A



18-6431
MOTOR ARRANQUE
Reemplaza: Tohatsu 346-76010-0A0
Para: 2cil 40C, 50C & 50A, 70A, NS25C, NS30A, NS35C, NS40C



18-6432
MOTOR ARRANQUE
Reemplaza: Tohatsu 3C8-76010-1
Para: M50D, M60B, M60C, MD40D, MD50A MFS25A, MFS30A, NS40D, NS50D, NS60C, NS70B, NS70C, NSD25A, NSD30A, NSD50A



18-6448
KIT CONVERSIÓN ELÉCTRICA
 Para: Tohatsu 25 & 30 HP



18-56001
ACOPAMIENTO ESCOBILLA
 Para: 90-140 HP 2 tiempos
 Usar con motor de arranque 18-6418



18-7712
FILTRO COMBUSTIBLE (EN LINEA)
 Reemplaza: 369022300M
 Para: 2 tiempos, 5 HP hasta 9.8 HP/4
 tiempos, 4 HP hasta 30 HP



Display Package

18-7828-1
 (1/4" Pequeño) Capacidad pequeña
 (Para línea combustible 1/4")

18-7829
 (1/4" Grande) Capacidad grande
 (Para línea combustible 1/4")

18-7830 (5/16")

18-7831 (3/8")

FILTRO COMB.

SEPARADORES AGUA/COMBUSTIBLE



Sierra ofrece una amplia gama de filtros separadores de agua de 10 y 21 micras incluyendo la cazoleta de drenaje para proteger tu carburador y la inyección.

Los filtros separadores de agua eliminan cerca del 98,8% del agua emulsionada de la gasolina. Los filtros Sierra de 10 micras tienen una eficiencia de cerca del 90% eliminando pequeñas partículas tan pequeñas como 10 micras. Todos los filtros tienen un caudal de 90 GPH. Los filtros Sierra de 10 micras son ideales para prevenir posibles daños en intrabordas sensibles y fueraborda de inyección.



18-8002S
BOMBA COMBUSTIBLE
1/4" (6-7 mm.)

18-8004 5/16"
112350 (8 mm.)
BOMBA COMB.
5/16" (8 mm.)
Entrada grande depósito

18-8005S 3/8"
112352 (8-10 mm.)
BOMBA COMB.
3/8" (10 mm.)
Entrada grande depósito



18-80410
CONECTOR COMBUSTIBLE
Reemplaza: 394-70250-0
5/16"
(Hembra)
Para: 4HP-30HP 4-tiempos
Acoplable 18-80417



18-8078
CONECTOR DEPÓSITO
1/4" N.P.T. .508 O.D.
Entrada grande depósito Nissan
Para: Todos modelos
Acoplable 18-8079
(Macho)



18-8079
CONECTOR COMBUSTIBLE
(Depósito)
Reemplaza: 3B2-70281-0, 65750-95500
Para: Todos los modelos
Acoplable 18-8078
Hembra para manguera de 3/8"



112321
CONECTOR COMBUSTIBLE
(Terminal combustible)
Reemplaza: 345-70250-0
3/8" manguera
Para: 5-90HP 2-tiempos y TLDI modelos
Acoplable 18-8089



18-8089
CONECTOR COMBUSTIBLE
(Terminal motor)
Reemplaza: 3B2-70260-0
(Rosca metrica)
5/16" manguera
Para: 5-90HP 2-tiempos y TLDI modelos
Acoplable 18-8088



Pack. de 10
ABRAZADERAS
18-8020 **18-8021**
18-8020-9 **18-8021-9**
#8 para mang. 5/16" #10 para mang. 3/8"



18-7290
KIT CARBURADOR
Reemplaza: 345-87122-0
Kit contiene componentes para la
reparación de 2 carburantes
Para: Todos 35/40C HP (1 por motor)



18-7291
KIT CARBURADOR
Reemplaza: 346-87122-0
Para: Todos 25/30 HP (1 por motor);
Todos 45A2, 50C, 60C, 70A2 (2 por motor)



18-7765
KIT CARBURADOR
Reemplaza: 369-87122-1
Para: Todos 4/5 HP (1 por motor)



18-8920
IMPULSOR
Reemplaza: 3B2-65021-1
Para: 8 (8B modelos), 9.8 (9.8B modelo), 8
4-tiempos (Todos), 9.8 4-tiempos (Todos)



18-8921
IMPULSOR
Reemplaza: 334-65021-0
Para: 9.9 (Todos), 15 (Todos), 18 (To-
dos), 9.9 4-tiempos (Todos B Modelos),
15 4-tiempos (Todos B Modelos), 18
4-Tiempos (Todos)



18-8922
IMPULSOR
Reemplaza: 3C8-65021-2
Para: 40 3-cil (D modelos), 40 TLDI
2-tiempos(Todos) 50 3-cil (D modelos),
50 TLDI 2-tiempos (Todos), 70 TLDI
2-tiempos(Todos), 90 TLDI 2-tiempos



18-8923
IMPULSOR
Reemplaza: 345-65021-0
Para: 25 (25C modelo), 25 4-tiempos (To-
dos A Modelos, B Modelos con cojinete
blanco), 30 (30A modelo), 30 4-tiempos
(Todos A Modelos, B modelos con coji-
nete blanco), 40 2-cil (40C modelo)



18-8924
IMPULSOR
Reemplaza:
3C7-65021-1, 3B7-65021-2
Para: 60 3-cil (B & C modelos), 70 3-cil
(B & C modelos), MD 70, MD 90(TLDI),
115, 140, 90 2-tiempos



18-45404
IMPULSOR
Reemplaza: 353650210M
Para: Nissan/Tohatsu NS50C, NS60A,
NS70A2(2002 & Sup)



18-43175
KIT TERMOSTATO
Reemplaza: 3R3-01030-0
Para: Nissan/Tohatsu 9.9-30 HP 4-tiempos

① Precio por envase ② pack de 10 - Precio por envase

APLICACIONES IMPULSORES EN LA PÁGINA 380



18-43212
BOMBA AGUA ALOJAMIENTO
 Reemplaza: 3B2-65016-0
 Para: 8/9.9 4-tiempos(209cc)

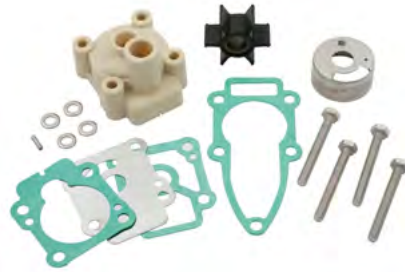

18-48317
KIT BOMBA DE AGUA COMPLETO
 Reemplaza: 3B2-87322-0
 Para: F8/9.8



18-7911-1
1879111 Easterner
FILTRO ACEITE
 Reemplaza: 3R0-07615-0
 Para: 9.9-30HP

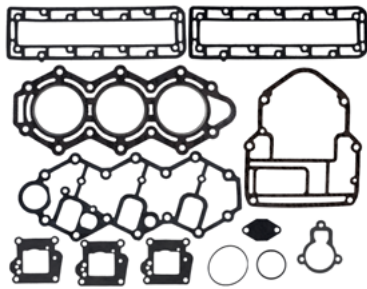

18-4434
JUEGO JUNTAS CULATA
 Reemplaza: 3B2-87321-0
 Para: Todos 40-50 HP

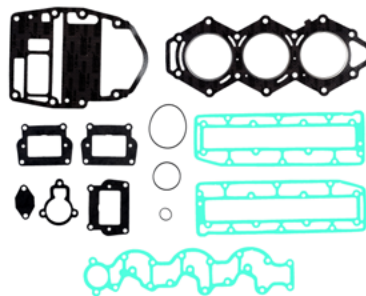

18-4435
JUEGO JUNTAS CULATA
 Reemplaza: 3F3-87121
 Para: Todos 60-70 HP

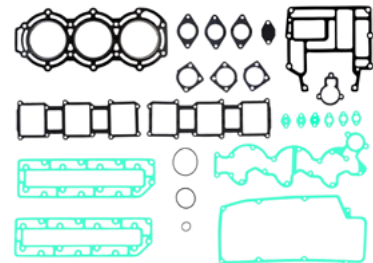

18-4436
JUEGO JUNTAS CULATA
 Reemplaza: 3B7-87121-1 ss -7
 Para: Todos 90 HP

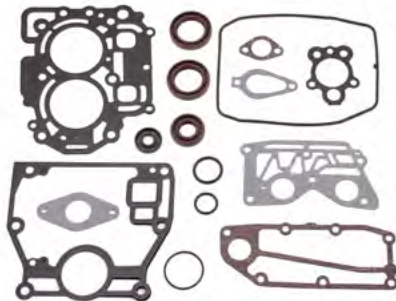

18-64221
JUEGO JUNTAS CULATA
 Reemplaza: 3V1-87121-0
 Para: Mercury 8/9.9(R042475 & Sup)

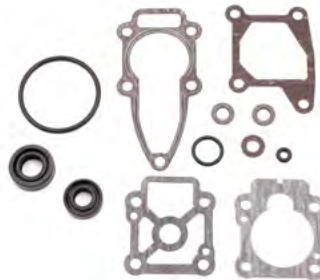

18-74805
KIT SELLADO UNIDAD INFERIOR
 Reemplaza: 3B2-87321-0
 Para: Nissan/Tohatsu F8/F9.9



18-74610
KIT SELLADO UNIDAD INFERIOR
 Reemplaza: 398-87321-0
 Para: 18 & 15 (1997-08); 9.9 (1997-04)

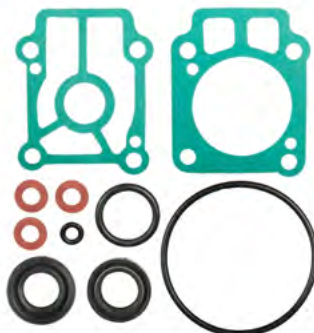

18-74611
KIT SELLADO UNIDAD INFERIOR
 Reemplaza: 346-87321-6
 Para: 25 (1997-05); 30 (1997-03)



18-3850
JUNTA CULATA
 Reemplaza: 3C8-01005-4 ss to -5
 Para: Todos 40-50 HP

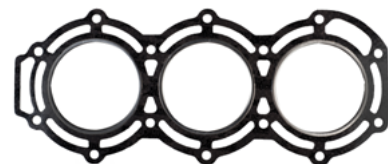

18-3886
JUNTA CULATA
 Reemplaza: 3T9-01005-0
 Para: Todos 90 HP



18-4299
JUNTA CULATA
 Reemplaza: 3F3-01005-0 ss to -01
 Para: Todos 60-70 HP



18-51000
MUELLE ARRANQUE DE RETR.
 Reemplaza: 3AA-05004-0
 Para: Tohatsu 8 4-tiempos(2004-12), 9.8
 4-tiempos(2004-12)

TAPÓN DE VACIADO JUNTAS



18-60103
 Reemplaza: 332600060M
 Para: Todos Nissan/Tohatsu
 modelos

18-60103-50
 Para: Todos Nissan/Tohatsu modelos



18-60916
CILINDRO JUNTA CULATA
 Reemplaza: 3V1-01005-0
 Para: F8/9.8



18-60917
JUNTA TAPA CILINDRO
 Reemplaza: 3V1-01024-0
 Para: F8/9.8



18-60918
JUNTA DE LA BASE MOTOR
 Reemplaza: 3V1-01303-0
 Para: F8/9.8



18-60919
JUNTA TAPA ESCAPE
 Reemplaza: 3V1-02305-0
 Para: F8/9.8



18-60920
JUNTA TERMOSTATO
 Reemplaza: 346-01032-0
 Para: F8/9.8



18-2448
LLENADO UNIDAD INF./
KIT DE DRENAJE
 M8 - 1.25 dientes
 Para: Yamaha, Nissan/Tohatsu, &
 Honda unidades inferiores



18-72656
TAPÓN DE DRENAJE Y JUNTA
 Reemplaza: Nissan-Tohatsu
 332600051M, 332600060M
 M8 - 1.25 dientes
 Para: Nissan/Tohatsu - Todos los modelos



18-73964
KIT DE TUERCAS
 Para: Nissan/Tohatsu F8/9.8



18-79989
ARRASTRE STICKS
 Para: mayoría de fuera bordas 150HP con
 tilt/trim integral.



18-76695
ARO TÓRICO
 Reemplaza: Nissan-Tohatsu
 3R0-07422-0
 Para: 8/9.9 s/n 0r042475 y Sup



TOHATSU



POTENCIA HP	CHAMPION	Ref. PRONAUTIC	POTENCIA HP	NGK	Ref. PRONAUTIC
MODELOS 2T			MODELOS 2T		
3.5HP M3.5A, M3.5B	L87YCC	050985	2.5 HP M2.5A 75cc	BPR6HS	050827
5HP M5B, M5BS	L82YC	050909	3.5 HP M3.5A/M3.5B 75cc	BPR6HS	050827
6HP M6B	L82YC	050909	4 HP M4C	BPR7HS	050829
8HP M8A, M8B 2Cil.	L82YC	050909	5 HP B13B, B9B	BR6HS	050714
9.9HP M9.9B2, M9.9C 2Cil.	L82C	050937	5 HP M5B, M5BS	BPR7HS-10	050843
9.8-12HP B18C, B18D	L86C	050910	6 HP M6B	BPR7HS	050829
12HP M12B	L82C	050937	8 HP M8A, M8B 169cc	BPR5HS	050874
15HP M15A,M15B2,M15C,M15D	L82C	050937	8 HP Proof 8 BEF, 169cc	BPR7HS	050829
16HP M16	L82C	050937	8 HP B13B, B9B	BPR6HS	050827
18HP M18A,M18C2,M18D,M18E	L82C	050937	9.8 HP B18C, B18D	BPR6HS	050827
20HP M20	L82C	050937	9.9 HP M9.9B2/M9.9C	BPR7HS	050829
20-25HP B40A, B30C	L86C	050910	12 HP M12B	BPR7HS-10	050843
25HP M25C, M25C2 2Cil.	L82C	050937	12 HP B18C, B18D	BPR6HS	050827
30HP M30A, M30A3 2Cil.	L82C	050937	13 HP M13	BPR7HS-10	050843
35HP M35A	L82YC	050909	15 HP M15A/M15B2/M15C/M15D	BPR7HS-10	050843
40HP M40C 2Cil., M40D 3Cil.	L82YC	050909	16 HP M16	BPR7HS-10	050843
50HP M50C, M50D 3Cil.	L78C	050907	18 HP M18A/M18C2/M18D/M18E 294cc	BPR7HS-10	050843
70HP M70A,M70A2,M70B	L78C	050907	20 HP M20	BPR7HS-10	050843
90HP M90A 3Cil.	L78C	050907	20 HP B40A, B30C	BPR7HS-10	050843
115HP M115A 4Cil.	L78C	050907	25 HP Proof 25C2 430cc	BPR7HS-10	050843
140HP M140A 4Cil.	L78C	050907	25 HP M25C, M25C2	BPR7HS-10	050843
MODELOS 4T			25 HP B40A, B30C	BPR7HS-10	050843
4 HP MFS4, OHV	RA8HC	050957	30 HP M30A/M30A3 400cc	BPR7HS-10	050843
5 HP MFS5A, OHV	RA8HC	050957	35 HP M35A	BPR7HS	050829
5 HP MFS5C, OHV	RA8HC	050957	40 HP MD40B TLDI	PZFR6H	050886
9.9 HP MFS9.9A, OHV	RA8HC	050957	40 HP M40D2 697cc	BPR7HS	050829
15 HP MFS15A, OHV	RA8HC	050957	40 HP Proof 40D Mega 697cc	B8HS-10	050810
			40 HP Proof 40D Mega 697cc EFTO	B8HS-10	050810
			40 HP M40D Mega EPTO 697cc	BR7HS	005053
			40 HP M40C 493cc	BPR6HS-10	050827
			40 HP MD40A TLDI	ZFR6F-11	050723
			50 HP 697cc	B8HS-10	050810
			50 HP MD50A TLDI	ZFR6F-11	050723
			50 HP MD50B TLDI	PZFR6H	050886



TOHATSU



POTENCIA HP	NGK	Ref. PRONAUTIC
50 HP W50	PZFR6H	050886
50 HP M50C/M50D	B8HS-10	050810
55 HP M55A/B	B8HS-10	050810
60 HP 938cc M60A/M60B/ M60C	B8HS-10	050810
70 HP MD70A 2 TLDI	ZFR6F-11	050723
70 HP MD70B TLDI	IZFR5J	050724
70 HP 938cc M70A/M70A2/	B8HS-10	050810
80 HP M80A	B8HS-10	050810
90 HP 1267cc M90A	B8HS-10	050810
90 HP MD90B TLDI	IZFR5J	050724
90 HP MD90A TLDI	ZFR6F-11	050723
90 HP MD90A 2 TLDI	ZFR6F-11	050723
115 HP MD115A TLDI	IZFR5J	050724
115 HP M115A/A2	B8HS-10	050810
120 HP 1768cc M120A	B8HS-10	050810
140 HP 1768cc M140A	B8HS-10	050810
MODELOS 4T		
2.5 MFS 2.5A	DCPR6E	050859
3.5 MFS 3.5A	DCPR6E	050859
4 MFS 4A	DCPR6E	050859
5 MFS 5A	DCPR6E	050859
6 MFS 6A	DCPR6E	050859
8 MFS 8A	DCPR6E	050859
9.8 MFS 9.8A	DCPR6E	050859
9.9 MFS 9.9A/B	DCPR6E	050859
15 MFS 15A/B/B2	DCPR6E	050859
18 MFS 18B4/18B	DCPR6E	050859
25 MFS 25A	DCPR6E	050859
30 MFS 30A	DCPR6E	050859



HÉLICES BAEKSAN

Baeksan fabrica miles de hélices desde el año 1984. Nuestras helices de altas prestaciones fabricadas con los mejores materiales aseguran una larga vida y una navegación tranquila y sin sobresaltos.

Sus palas compensadas ofrecen una reducción significativa de la vibraciones.

Cojinete de goma insertado en el nucleo en versión fija o nucleo intercambiable.





Mano de pintura de alto grosor para evitar la corrosión.

En caso de no conocer la referencia original de la hélice a reemplazar siga los siguientes pasos:

- 1-Comprueba el rango de Revoluciones por minuto (RPM) del fabricante del motor en el manual.
- 2-Comprueba las RPM maximas del motor leyendo el panel para determinar el paso y velocidad optimo.
- 3-Si las RPM maximas exceden el rango recomendado, disminuye las RPM utilizando un paso superior.
- 4-Si las RPM son mas bajas que el rango recomendado, aumenta las RPM utilizando un paso inferior.







Si no localiza la hélice que necesita contacte con nuestro departamento técnico.

TOHATSU / NISSAN

Tipo	Modelo Fueraborda	Referencia-Diam./Paso	Ref. original	Pala	Núcleo
T5	 <p>4 - 6 hp</p> <ul style="list-style-type: none"> • M4C / 5B (2 tiempos) • MFS4 / 5 / 6 (4 tiempos) <p>Escape a través del núcleo, 12 estrias</p>	62M57788 7 7/8x8	3R1B64516-2	3	Fijo
		Utilizar hélice Mercury			
T8	 <p>8 - 9.8 hp 2-1/2" Caja de engranajes</p> <p>Para Nissan/Tohatsu Fueraborda:</p> <ul style="list-style-type: none"> • 8hp (2 tiempos) Todos los años • 8hp MFS8 (4 tiempos) Todos los años • 8hp NSF8 (4 tiempos) Todos los años • 9.8hp (2 tiempos) Todos los años • 9.8hp MFS9.8 (4 tiempos) Todos los años • 9.8hp NSF9.8 (4 tiempos) Todos los años <p>Para motores Mercury:</p> <ul style="list-style-type: none"> • 8hp (4 tiempos) 2005 y posteriores <p>Escape a través del núcleo, 12 estrias</p>	62T88127 8 1/2x7	3B2-64513-0	3	Fijo
		62T88128 8 1/2x8	3B2B64515-1	3	
A	 <p>9.9 - 20 hp 2-1/2" Caja de engranajes</p> <ul style="list-style-type: none"> • 9.9hp (2 tiempos) 1984 y posteriores • 9.9hp (4 tiempos) 2000-2003 • 12hp 1985-1988 • 15hp (2 tiempos) 1985 y posteriores • 15hp (4 tiempos) 2000 y posteriores • 18hp (2 tiempos) 1985 y posteriores • 18hp (4 tiempos) 2001-2008 • 20hp (4 tiempos) 2007 y posteriores <p>Escape a través del núcleo, 14 estrias</p>	62T159148 9 1/4x8	3BAB64516-0	3	Fijo
		62T159149 9 1/4x9	3BAB64518-0	3	
		62T15914934 9 1/4x9 3/4		3	
		62T1591410 9 1/4x10	362-64108-0	3	
		62T159141012 9 1/4x10 1/2	3BAB64521-0	3	
		62T1591411 9 1/4x11		3	
		62T1591412 9 1/4x12		3	
B	 <p>25 - 30 hp 3" Caja de engranajes</p> <p>Para Nissan/Tohatsu Fueraborda:</p> <ul style="list-style-type: none"> • 25hp 1986-2001 • 25hp (4 tiempos) 2002 y posteriores • 30hp 1985-2001 • 30hp TLDI 2016 y posteriores • 30hp (4 tiempos) 2002 y posteriores <p>Para motores Mercury:</p> <ul style="list-style-type: none"> • 25hp (4 tiempos) 2006 y posteriores • 30hp (4 tiempos) 2006 y posteriores <p>Escape a través del núcleo, 10 estrias</p>	62T309789 9 7/8x9	3R0B64518-0	3	Fijo
		62T3097810 9 7/8x10	3R0B64521-0	3	
		62T3097811 9 7/8x11	3R0B64523-0	3	
		62T3097812 9 7/8x12	3R0B64525-0	3	
		62T3097813 9 7/8x13	3R0B64527-0	3	
		62T309781414 9 7/8x14 1/4	349B64529-1	3	

BS.PRO aluminum propellers are the crystals of our endeavor.



Tipo	Modelo Fueraborda	Referencia-Diam./Paso	Ref. original	Palas	Núcleo	
C	 35 – 60 hp 3-1/4" Caja de engranajes • 35hp (solo 35B) hasta 1984 • 40hp 1984 y posteriores • MFS40 2015 y posteriores • 50hp 1992 y posteriores • MFS50 2015 y posteriores • BFT60 2014 y posteriores	62T4012149 12 1/4x9	3T5B64518-0	3	Fijo	
		62T40113410 11 3/4x10		3		
		62T40115811 11 5/8x11	3T5B64523-0	3		
		62T40113812 11 3/8x12	3T5B64525-0	3		
		62T40111813 11 1/8x13	3T5B64527-0	3		
		62T40111414 11 1/4x14	3T5B64529-0	3		
	 Escape a través del núcleo, 13 estrias  50 – 70 hp 3-1/4" Caja de engranajes • 50hp (solo 50C) 1987-1991 • 55hp 1981-1988 • 60A y 60B 1986-1999 • 70A y 70B 1981-1995 Escape a través del núcleo, 13 estrias	62U4012149 12 1/4x9		3	Interc. 62BHTC	
		62U40113410 11 3/4x10		3		
		62U40115811 11 5/8x11		3		
		62U40113812 11 3/8x12		3		
		62U40111813 11 1/8x13		3		
		62U40111414 11 1/4x14		3		
		624U40105812 10 5/8x12	48-8M8026625	4		
		624U40103813 10 3/8x13	48-8M8026630	4		
		624U40101814 10 1/8x14	48-8M8026635	4		
		624U40101815 10 1/8x15	48-8M8026640	4		
		62U48121213 12 1/2x13		3		Interc. 62BHTC48
		62U48121415 12 1/4x15		3		
D	 60-140 hp 4-1/4" Caja de engranajes • 60C (Caja engranaje grande) hasta 1999 • 70C (Caja engranaje grande) hasta 2002 • 90hp 1987 y 2001 • 115hp 1992 y posteriores • 120hp 1988 y 2003 • 140hp 1988 y 2003 Escape a través del núcleo, 15 estrias ** Se puede instalar el tipo U en los motores más nuevos de la clase D de Tohatsu. (con núcleo intercambiable)	62T90135813 13 5/8x13	3N4B64527-1	3	Fijo	
		62T90131215 13 1/2x15	3N4B64532-1	3		
		62T90131417 13 1/4x17	3N4B64536-1	3		
		62T901319 13x19	3N4B64541-1	3		
		62T90125821 12 5/8x21	3N4B64545-1	3		
	 	62U601410 14x10	48-854342A45	3	Interc. 62BHTD	
		62U901411 14x11	48-77338A45	3		
		62U901413 14x13	48-77340A45	3		
		62U60133415 13 3/4x15	48-77342A45	3		
		62U90131417 13 1/4x17	48-77344A45	3		
		62U901319 13x19	48-77346A45	3		
		62U90123421 12 3/4x21	48-77348A45	3		
		624U90137811 13 7/8x11	8M8026560	4		
		624U90137813 13 7/8x13	8M8026570	4		
		624U90133815 13 3/8x15	8M8026580	4		
624U901317 13x17	8M8026590	4				
624U90121219 12 1/2x19	8M8026600	4				



009358 Zn 0,03 **Tohatsu.** Ánodo arandela para Tohatsu 4T MFS 8-30 HP. #OEM 369-60218-1/ #OEM 823912

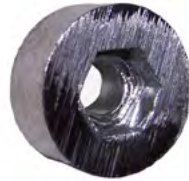

009360 Zn 0,02 **Tohatsu** Ánodo circular para culata Tohatsu 2,5-9,8HP. 25-70 HP. #OEM 338-60218-2

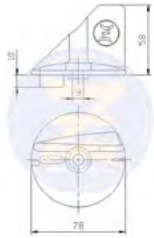

025741 Zn 0,33 **Tohatsu.** Ánodo aleta para estabilizador motor fueraborda Tohatsu 2T 25-50HP, 4T 25-30HP. #OEM 387-60217-0

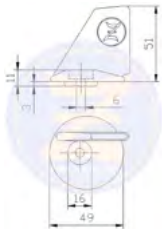

025740 Zn 0,14 **Tohatsu** Ánodo aleta para estabilizador de motor fueraborda Tohatsu M40C 2T. #OEM 338-60218-2

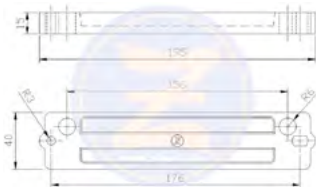

025742 Zn 0,5 **Tohatsu** Barra para transom fueraborda Tohatsu 2T 40-140 HP. #OEM 3C7-60218-2

GENERADOR PRODUCTOS

O.E. #	SIERRA #	O.E. #	SIERRA #	O.E. #	SIERRA #
FISCHER PANDA		NORTHERN LIGHTS		33417	23-0803
IC78.460.000A	23-1105	11-10015	23-0830	33966	23-0807
IC78.460.000B	23-1104	24-22009	23-1102	34093	23-2800
J009-1027B-1	23-3312	24-28003	23-1103	34113	23-2701
J009-46840	23-3311	25-12009	23-3315	34196	23-0802
JABSCO		25-12009	23-2005	34440	23-3307
22799-0001	23-2003	25-12031	23-0400	35109	23-5840
JOHNSON PUMP		ONAN		35595	23-7801
09-808B-1	23-2001	122-0185	23-7841	35608	23-2702
KOHLER		122-0810	23-7840	35610	23-2801
26987	23-7762	130-4434	23-6401	35736	23-3601
229432	23-0810	130-6228	23-6402	35828	23-7825
229433	23-0812	132-0349	23-3300	35920	23-7720
229678	23-7822	132-0436	23-3309	36450	23-7200
229715	23-7751	149-0428	23-7750	36918	23-7800
229826	23-2002	149-1445	23-7720	37387	23-3602
229826	23-3303	149-2106	23-7760	37922	23-0808
229955	23-3304	185-5835	23-7842	38100	23-7201
229963	23-0813	185-7444	23-7804	39181	23-4000
249433	23-7771	309-0130	23-3606	39378	23-3603
249865	23-0811	541-1519	23-3310	39705	23-1101
249930	23-3608	A026K278	23-7760	40154	23-7826
250872	23-2003	SHERWOOD		40434	23-0805
252896	23-3609	09000K	23-2002	40434	23-0805
252898	23-7740	10077K	23-2000	40859	23-2700
260085	23-6400	WESTERBEKE		40860	23-2802
267709	23-1100	11672	23-4001	42201	23-2804
267714	23-7823	11885	23-6400	42260	23-0800
267717	23-3610	11907	23-3301	43050	23-2803
267718	23-0809	13810	23-4005	43060	23-4500
278857	23-1130	24132	23-5880	45232	23-4003
279449	23-7820	24323	23-0806	46097	23-3604
326817	23-7803	24353	23-1000	46124	23-0801
352018	23-3607	24363	23-7764	46592	23-2703
352031	23-0814	24639	23-5800	46596	23-4501
352122	23-3308	24690	23-3605	46622	23-3306
359771	23-7821	26488	23-3600	47060	23-7770
359978	23-2004	30200	23-7770	48076	23-7802
359978	23-3314	30376	23-4007	24688 & 24323	23-3650
249930 & 29963	23-3664	30475	23-4004	24688 & 33966	23-3658
252896 & 229432	23-3665	30592	23-4002	24688 & 34196	23-3653
267717 & 267718	23-3663	30593	23-5600	24688 & 40434	23-3662
352018 & 352031	23-3666	30594	23-5900	24690 & 33373	23-3660
GM24510	23-7202	32620	23-3305	24690 & 33417	23-3657
GM32359	23-7761	33104	23-3313	35736 & 33417	23-3652
GM34570	23-7780	33112	23-3302	35736 & 34196	23-3651
GM47465	23-7824	33373	23-0804	35736 & 40434	23-3661
				37387 & 37922	23-3659
				39378 & 42260	23-3654
				39378 & 46124	23-3655
				46097 & 33417	23-3656

SIERRA MARINE PRODUCTOS

O.E. #	SIERRA #	O.E. #	SIERRA #	O.E. #	SIERRA #
A.C. DELCO		20-0082-P	18-4364	CM206672JP	18-4360
GF-61	18-7856-1	20-0100	18-1907	FM-1-83	18-1996
GF-61P	18-7857-1	20-0100	18-1939	FM-1-83	18-1998-1
ARCTIC CAT		20-0102	18-1907	FM-1-83-P	18-4363
0436-879	72-5100-3	200087P	18-1992-1	MC 1 58759	18-1960-1
0436-880	72-5100-2	200089P	18-1991	MC 1 96705	18-1955-1
0436-901	72-5102-4	CHV-1-83	18-196	MC 1 99798	18-1956-3
1436-159	72-5102-2	CHV-1-83	18-1997-1	MC-1-65603	18-1962-1
1436-434	72-5101-2	CHV-47-000	18-2949	MC-1-65604	18-1958-1
1436-435	72-5101-3	CHVA-1-84	18-1898	MC-1-77234	18-1950-1
4639-349	72-5103-2	CM 20-0097	18-1949	MC-1-77235	18-1951-1
5639-469	72-5103-3	CM-1-6672-B	18-1941	MC-1-99746	18-1952-1
ARCTIC CAT PWC		CM-1-6672-H	18-1942	MC-20-44354	18-1976-2
3008-093	18-6919	CM-1-6677A	18-1940	MC-20-55538	18-1973
3008-327	18-6919	CM-1-6677SS P	18-8527	MC-20-60207	18-4008
3008-462	18-6919	CM-20-414211	18-1944	MC-20-76325	18-1972
3008-536	18-6919	CM-20-6672	18-1946	MC-20-76771	18-1978
BARR		CM-20-6674	18-1945	MC-20-93322A3	18-1985
160252	18-4009	CM-20-6674JP	18-8506	MC-20-98502	18-1974-1
01-0105	18-0476-1	CM-20-6674JP	18-8507	MC-20-98504	18-1970-2
01-0107	18-2854-1	CM-20-6674P	18-4361	MC20-60426P	18-4362
1-73813	18-1990	CM-20-9232P	18-8518	OMC-1-914035	18-1986-1
20-0082	18-1999	CM-20-9234	18-1948	BORG-WARNER	
		CM-20-9234 P	18-8501	A4876HA	18-2590
BOSCH					
0-001-109-035	18-6944				
0331-302-050	18-5806				
0331-302-081	18-5806				
0331-302-085	18-5806				
0331-302-581	18-5806				
0331-302-585	18-5806				
BRP					
5007987	18-8387				
420956741	18-8880				
CAN-AM					
XPS #779139	72-5101-2				
XPS #779140	72-5101-3				
CATERPILLAR					
3001117	18-6955				
10-258	18-6955				
163-3361	18-6944				
1R-0658	18-7880				
1R-0714	18-7927				
CERLIST DIESEL					
1512903	18-7970				
1512904	18-7934				

O.E. #	SIERRA #	O.E. #	SIERRA #	O.E. #	SIERRA #	O.E. #	SIERRA #
CHRIS-CRAFT		26-814669A1	18-2635	47-F84065	18-3085	F83404	18-7127
1869704	18-5346	26-814669A2	18-2635	50-803900T	18-6441	F84068-2	18-3550
16.11-01236	18-2845	26-816464	18-8347	50-803903T	18-6439	F85068	18-3550
16.50-00074	18-0889	26-8164641	18-8347	50-819968	18-5618	F85068-1	18-3550
16.50-00078	18-0891	26-817472	18-0500	50-819968-2	18-5618	F85068-2	18-3550
16.50-00162	18-0874	26-819396	18-0502	50-8199681	18-5618	F85955-1	18-5613
16.50-00204	18-2946	26-820645A	18-2636	50-8199683	18-5618	F97068-2	18-3556
16.50-00232	18-0868	26-828627	18-8354	50-8199684	18-5618	FA305310-2	18-5150
16.50-00250	18-3876	26-85090A1	18-2629	50-820193	18-5622	FA663260	18-39010
16.50-00259	18-3877	26-85090A2	18-2624	50-820193T1	18-5622	FA85955	18-5613
16.50-05756	18-0876	26-99325	18-0586	50-898265003	18-5618	FK10003	18-7033
16.61-00042	18-5911	26-F318307	18-0592	50-F514955	18-6441	FK10004	18-7037
16.69-00039	18-5314	26-F346118	18-0584	50-F575955	18-6439	FK10005	18-7037
16.69-00040	18-5338	26-F40307-2	18-0503	700-834794A4	18-4630	FK10007	18-7037
16.69-00042	18-5411	26-F84307-1	18-0512	700-834794A5	18-4631	FK10008	18-7037
16.69-00049	18-5311	26-F901307-2	18-0593	700-834794T3	18-4629	FK10026	18-7033
16.69-00050	18-5345	27-19701	18-0622	700-834800A4	18-4632	FK10027	18-7037
16.69-00051	18-5418	27-819138-2	18-3859	700-834800A5	18-4633	FK10053	18-7033
16.69-00052	18-5385	27-819377	18-0873	700-834800A6	18-4634	FK10057	18-7037
16.69-00100	18-5375	27-820438	18-3855	815279T2	18-5742	FK10102-1	18-7033
16.69-00148	18-5376	27-820500A3	18-0869	815279T3	18-5742	FK10108	18-7037
16.69-00149	18-5404-1	27-824615	18-3857	815279T4	18-5744	FK1060	18-2630
16.69-0022	18-5427	27-824615-2	18-3857	815279T5	18-5744	FK1061	18-2631
16.81-06536	18-7875	27-828316	18-0314	817764A2	18-5150	FK1063-1	18-2632
16.81-08746	18-7824-2	27-F178168	18-0314	818903A1	18-6777	FK1063-2	18-2632
16.83-08758	18-7265	27-F178168-1	18-0314	819479A1	18-6777	FK1064	18-2637-1
16.83-90006	18-7860	27-F201529-1	18-3856	819480A1	18-6777	FK1065	18-2638
FI6900165	18-5375	27-F286529-3	18-3851	819762A4	18-6777	FK1068	18-2639
FI8308762	18-7265	27-F307279-2	18-0115	819762A7	18-6777	FK1074	18-2636
CHRYSLER FORCE		27-F372154-1	18-0958	81977A8	18-6777	FK1127	18-2633
75384	18-5697	27-F40223	18-0869	81977A9	18-6777	FK1203	18-2640
455541	18-6762	27-F40279-1	18-0154	822870A1	18-6777	FK1203-1	18-2640
811902	18-5677	27-F406406	18-0915	827675A1	18-6286	FK1234	18-2635
817411	18-5742	27-F440906	18-0315	830179A1	18-5744	FK616955	18-5613
819222	18-5673	27-F476067	18-0854	830179A2	18-5742	F010790	18-7041
820545	18-6279	27-F476529-4	18-3857	830250A3	18-6777	F016311	18-7041
824051	18-6775	27-F481836	18-0152	830250T3	18-6777	FP2437A	18-5149
1736073	18-7264	27-F513529	18-3852	832021A1	18-6777	FRK739	18-7037
2279913	18-7264	27-F523031	18-0415	832021A2	18-6777	FS409752	18-8011EP-2
3745414	18-7254	27-F658529	18-3854	832021T2	18-6777	FS438955	18-5613
3745415	18-7255	27-F691529-1	18-3853	832021T4	18-6777	FS438955	18-5613
8152792	18-5742	27-F694830	18-0416	854514A1	18-5744	FS480955	18-5613
8152794	18-5744	27-F84031	18-0417	855654A1	18-6777	FS489955	18-5613
8174111	18-5744	27-F85154-1	18-0119	855654T2	18-6777	FS490955	18-5613
11-35921	18-3719	27-F85168-2	18-0855	856747T1	18-5744	L-319	18-7879-1
11-47411	18-3719	27-F85748-2	18-0861	883071A1	18-5744	CHRYSLER INBOARD	
11-826375	18-3719	27-F85762	18-0141	89-803822T	18-5835	10612	18-0499
11-F694188	18-3719	27-F85906	18-0960	89-817109A2	18-5834	10927	18-3168
18495A26	18-5790	27-F97067	18-0873	89-817109A3	18-5835	56874	18-7875
19217A1	18-6777	31-F523143	18-1113	89-F460917-1	18-5835	200691	18-5435
19217A5	18-6777	31-F523901	18-1112	F010790	18-7057	201522	18-5433
19291A3	18-2370	332-5772A5	18-5881	F12042-1	18-5169	868095	18-5430
197787-3	18-8062	332-5772A7	18-5881	F12044	18-5149	868096	18-5404-1
21-42990A10	18-7817	332-7778A12	18-5775	F12181-1	18-5241	1274092	18-5307
21-42990A7	18-7817	339-7370A13	18-5186	F15100	18-5673	1658535	18-5407
21-42990A8	18-7817	339-7370B13	18-5186	F15110	18-5673	1692658	18-5841
21-42990A9	18-7817	339-832757B4	18-5186	F15150	18-5655	1736073	18-7264
21-857005A1	18-7817	39-817869A1	18-39010	F15164	18-5697	1818757	18-5347
25-20195	18-7134	39-820457A2	18-3998	F177917	18-5803	1851658	18-7875
25-201951	18-7134	39-820641A1	18-3999	F178168	18-0314	2084074	18-5307
25-32507	18-7127	398-176	18-5206	F184122-1	18-2534	2095946	18-5723
25-45258	18-7950	398-832075A4	18-5870	F24747-1	18-7805	2098058	18-5345
25-85549	18-7956	398-832075A6	18-5873	F335068	18-3557	2098300	18-5710
25-85594	18-7100	44-850308	18-2254	F438955-1	18-5613	2098611	18-5429
25-88657	18-7952	449541-3	18-6762	F460917-1	18-5835	2279913	18-7264
25-F24278	18-7169	46-43024A7	18-3214	F476529	18-3857	2279949	18-5345
25-F45530	18-7457	47-19453	18-8900	F476529-1	18-3857	2421173	18-5303
25-F498618	18-7120	47-42038-2	18-3062	F476529-2	18-3857	2421178	18-5307
25-F74305	18-7176	47-430262	18-3056	F480955	18-5613	2421820	18-5314
25-F84305	18-7127	47-803630T	18-3030	F490955	18-5613	2463441	18-3645
26-41131	18-0579	47-803631T	18-3017	F523065	18-3030	2469556	18-1913
26-41132	18-0580	47-85089-3	18-3057	F523065-1	18-3030	2469559	18-2941
26-41365A3	18-2697-1	47-89984T4	18-3017	F528068	18-3559	2469639	18-1913
26-43035	18-0583	47-F40065-2	18-3084	F616955	18-5613	2495531	18-5433
26-43035A4	18-2626	47-F433065	18-45003	F694541-1	18-6279	2808870	18-5303
26-66022	18-0584	47-F436065-2	18-8903	F697140	18-3200	2846106	18-1941
26-76384	18-8347	47-F462065	18-8901	F718470	18-5742	2846689	18-1945
		47-F694065	18-3017	F746470	18-5742		

O.E. #	SIERRA #	O.E. #	SIERRA #	O.E. #	SIERRA #	O.E. #	SIERRA #			
2847404	18-1944	38071	18-5405	7243200	18-5443	S114-257G	18-6880			
2847405	18-1913	40057	18-3169	9002514	18-7875	S114-303	18-6937			
2847480	18-2941	41052	18-5369	R130012	18-15214	S114-303A	18-6937			
2847527	18-5710	41057	18-5345	RO29015	18-1938	S114-483	18-6880			
2847623	18-1944	41058	18-5303	RP061022	18-8926	S114-483A	18-6880			
3004886	18-3581	41059	18-5407	CUMMINS				S114-559B	18-6861	
3420600	18-5347	41061	18-5399	160596	18-3078	S114-682	18-6942			
3527501	18-5954	41069	18-5353	166758	18-3078	S114-837	18-6831			
3527502	18-5954	41074	18-5403	214169	18-6952	S114-837A	18-6831			
3527794	18-1946	41076	18-5352	216040	18-5982	S13-68	18-6934			
3549957	18-7878-1	41080	18-5435	556540	18-3078	S13-68A	18-6934			
3619542	18-3581	41089	18-5403	556850	18-3078	S13-68C	18-6934			
3619859	18-3582	42001	18-5717	650607	18-3077	S13-86	18-6934			
3656017	18-5102	42090	18-5907	3920618	18-6952	HONDA				
3675826	18-1940	42091	18-5908	21601R	18-3078	06192-881-C00	18-3279			
3675826	18-1942	45303	18-7200	3603853RX	18-6952	06192-ZV1-C00	18-3278			
3744870	18-5954	45334	18-7095	3604234RX	18-5982	06192-ZV4-000	18-3280			
3745215	18-28019	47002	18-7600	DELCO				06192-ZV4-A00	18-4536	
3745217	18-0607	47032	18-7630	1100077	18-6952	06192-ZV5-003	18-3282			
3745220	18-4346	47033	18-7632-1	1100093	18-6952	06192-ZV7-000	18-3281			
3745414	18-7254	47047	18-7958	1100211	18-6952	06192-ZW1-000	18-3283			
3745415	18-7255	51080	18-5433	1100211	18-6952	06192-ZW1-305	18-3187			
3745639	18-1944	91351	18-2845	1100274	18-6952	06192-ZW1-B04	18-3492			
3745985	18-3581	91606	18-7862	1105474	18-6952	06192-ZW9-000	18-3493			
3780600	18-5103	96108	18-0305-1	1105475	18-6952	06192-ZW9-A30	18-3478			
3874020	18-5105	96120	18-1925	1105476	18-6952	06192-ZX2-C00	18-3489			
3874767	18-5451	96121	18-1926	1114356	18-5838	06192-ZY3-000	18-3285			
4106140	18-5450	96216	18-0306-1	1114458	18-5838	06192-ZY6-000	18-3284			
4142322	18-1940	96306	18-2949	1115202	18-5433	08208-0080	72-5102-2			
4142408	18-5369	96319	18-3551	10459244	18-6952	15400-PFB-007	18-7911-1			
4142817	18-5352	96358	18-3552	DENSO				15400-PFB-014	18-7913	
4142880	18-3860	96562	18-0309-1	995435	18-6868	15400-PLM-A01PE	18-7909			
4142885	18-3551	96653	18-0418	101211-3020	18-6960	15400-POH-305	18-7909			
4142886	18-7230	96938	18-2434	101211-3021	18-6960	15400-POH-305PE	18-7909			
4273129	18-0609	97039	18-7272	101211-3460	18-6844	15400-ZJI-004	18-7909			
4417375	18-3878	97114	18-1929	101211-9940	18-6849	16010-881-003	18-2482			
4417905	18-3581	97115	18-1933	128000-4860	18-6868	16010-ST5-993	18-7785			
24695566	18-1942	97169	18-1916	128000-4861	18-6868	16010-ZV4-005	18-2480			
118-614	18-0956-1	97214	18-7231	128000-4862	18-6868	16010-ZW9-003	18-2481			
7087-OR	18-7512	97296	18-1917	128000-4863	18-6868	16011-881-741	18-7048			
E9234M	18-1948	97361	18-3671	128000-4864	18-6868	16011-ZV4-005	18-7047			
E9923M	18-1944	97386	18-1918	228000-4550	18-6867	16176-POA-004	18-0737			
F724002	18-7875	97387	18-1919	428000-0081	18-6873	16201-881-850	18-2473			
L-1008	18-7878-1	97498	18-2909	DETROIT DIESEL				16221-ZV4-610	18-2470	
L-19	18-7878-1	97595	18-7231	5574508	ELECTROLUX				16221-ZW1-000	18-2472
CRUSADER				5574508	ELECTROLUX				16221-ZW9-000	18-2471
12525	18-5310	97624	18-1924	ELECTROLUX				16900-SA5-004	18-7786	
12526	18-5344	97686	18-0311	5024/120	18-6758	16900-SR3-004	18-7720			
12528	18-5384	97752	18-1925	KS3448/290	18-6790	16901-ZY3-003	18-79909			
12530	18-5338	97753	18-1926	EVINRUDE				16910-GB2-005	18-7712	
12531	18-5411	97772	18-1927	587078	18-5909	16910-ZV4-015	18-8226			
12532	18-5375	97854	18-8112	587291	18-5909	16910-ZVL-003	18-7521			
20117	18-5314	97895	18-3649	FRAM				16911-ZY3-010	18-79908	
20129	18-0976	97924	18-1928	CCS 1136	18-7935	16977-ZV5-900	18-80406			
20129	18-0976	97992	18-1929	GLM				16977-ZV5-A00	18-80400	
20222	18-5376	97993	18-1933	21090	18-2163E-9	17105-ZY3-004	18-0390			
20223	18-5404-1	98041	18-7846	GM				17105-ZY6-000	18-0300	
20223	18-5404-1	98068	18-1934	3701777	18-2917	17109-XY6-000	18-0382			
20300	18-3061	98125	18-1982	6269358	18-3577-2	17109-ZY3-004	18-0396			
20309	18-3168	98126	18-1938	6269577	18-3876	17151-ZW5-00	18-0248			
20318	18-3599-2	98128	18-1984	6414989	18-7258	17650-921-003ZB	18-80420			
20502	18-3140	98128	18-1984	10482803	18-5117	17650-ZW9-003	18-80408			
21140	18-7270	201104	18-7824-2	14077948	18-4173	17660-ZV5-902	18-38008			
21141	18-7271	201104	18-7876-1	14077949	18-4164	17670-ZW1-030GH	18-7947			
22212	18-3060	700425	18-5899	14089025	18-3937	17670-ZW1-801AH	18-7948			
22687	18-7852-1	700427	18-5898	14089026	18-3938	17700-ZW9-010	18-81042EP-2			
22687	18-7852-1	705786	18-5427	14089026	18-3938	17700-ZW9-020	18-81042EP-2			
23250	18-7976	705787	18-5345	HITACHI				17710-ZW9-033	18-80407	
30103	18-3577-2	705788	18-5307	129470-77200	18-6929	19021-ZW1-003	18-3214			
30266	18-3877	705788	18-5307	LR135-105	18-6925	19210-881-A01	18-3245			
31136	18-3887	707125	18-5717	LR135-74	18-6928	19210-881-A02	18-3245			
31137	18-3874	1003026	18-3060	LR135-74B	18-6928	19210-ZV4-013	18-3246			
31137	18-3874	1003062	18-3046	LR180-03A	18-6929	19210-ZV4-651	18-3246			
32722	18-7256	1003317	18-5375	LR180-03B	18-6929	19210-ZV4-651	18-3247			
33393	18-4408	1003317	18-5375	LR180-03B	18-6929	19210-ZV5-003	18-3248			
33408	18-3879	1003318	18-5411	LR180-03C	18-6929	19210-ZV7-003	18-3249			
33628	18-7232	3000121	18-5389	LR180-03C	18-6929	19210-ZW1-003	18-3056			
37061	18-5313-1	3000122	18-5420	S114-257	18-6880					
37068	18-5433	3000124	18-5318							
37068	18-5438	7057500	18-3876							
38070	18-5354	7142520	18-3599-2							
		7243110	18-5107-1							

O.E. #	SIERRA #	O.E. #	SIERRA #	O.E. #	SIERRA #	O.E. #	SIERRA #
HONDA cont.		91301-ZG3-000	18-71335	JOHNSON PUMP		4140M	18-34140
19210-ZW1-B04	18-3250	91353-ZW1-003	18-7198	01-42401	18-3303	5110MFI	18-34120
19210-ZW9-003	18-3100	91356-ZY3-003	18-8299	09-1026B	18-3080	9-26103	18-5339-1
19210-ZW9-013	18-3100	HP2	72-5103-2	09-1026B-1	18-3080	9-29418	18-5397
19210-ZW9-A02	18-3245	HP2	72-5103-3	09-1026B-9	18-3036	9-34081	18-7489
19210-ZW9-A31	18-32455	HP2	72-5103-4	09-1026B-9	18-3080	9-72152	18-2163E-9
19210-ZW9-A32	18-32455	HP2	72-5103-5	09-1026B-9	18-3080	YL512CV	18-5309-1
19210-ZY3-003	18-3031	HP2	72-5103-7	09-1027B	18-3081	YL554CV	18-5312-1
19231-ZW1-003	18-3122	HP4	72-5100-2	09-1027B-9	18-3020	YL566AV	18-5339-1
19232-881-850	18-2608	HONDA PWC		09-1028B	18-3077	YL567EV	18-26104-1
19232-ZV1-A10	18-2524	31200-HW1-671	18-6877	09-1028B-9	18-3038	YL579AV	18-26110-1
19232-ZV4-610	18-2495	ILMOR		09-1029B	18-3078	YL624AV	18-5313-1
19232-ZW1-003	18-2563	MV8V1021	18-57824	09-1029B-9	18-3037	YL624BV	18-5316-1
19232-ZW9-000	18-99153	S556162	18-32152	09-1029B	18-3037	YL624MMW	18-5313-1
19233-ZV5-000	18-2496	ILMOR / MASTERCRAFT		09-1029B	18-3077	YL648AV	18-26111-1
19234-881-850	18-2609	550022689	18-9558-2	09-45589	18-3076	YL673AV	18-5315-1
19234-ZW1-003	18-2564	550046126	18-9558-4	09-45589	18-3510	YL700AV	18-26107-1
19234-ZW1-003	18-2564-1	INDMAR		09-45825	18-3089	YLM512CV	18-5495-2
19234-ZW1-B00	18-0481	573001	18-5603-1	09-801B	18-3075	YLM554CV	18-5489-2
19234-ZX2-C00	18-99154	575010	18-6288	09-802-B	18-3304	YLM566AV	18-26311-2
19234-ZY3-000	18-2499	575011	18-5984	09-806B	18-3079	YLM567CV	18-5496-2
19242-ZV5-000	18-0176	575014	18-6451	09-808B	18-3076	YLM624BV	18-5498-2
19242-ZW1-003	18-2565	685001	18-3587-1	09-810B	18-45713	YLM624BV	18-5498-2
19242-ZW1-B00	18-0482	685011	18-3586-1	09-812B	18-3306	YLM673AV	18-5486-2
19300-881-741	18-3629	751007	18-5303	09-819B	18-3275	YLM673AV	18-5486-2
19300-881-761	18-3627	755017	18-5345	09814B	18-45712	YLM676AV	18-5487-2
19300-ZV5-043	18-3630	755021	18-5277	10-24228-1	18-3586-1	YLM700AV	18-26310-2
19300-ZW9-003	18-3628-1	872003	18-9555-2	10-24232-1	18-3587-1	MANDO	
30520-PNA-007	18-7494	872005	18-9554-2	3298-0000	18-3125	A000B0341	18-6843
30520-PWC-003	18-23251	872006	18-9554-4	JOHNSON/EVINRUDE		TA000B0341	18-6843
30530-P8F-A01	18-7559	872025	18-8779	302035	18-71336	MARINE POWER	
30530-PPL-A01	18-7558	0170-000	18-5603	302325	18-1597	402001	18-6299
31200-ZV5-013	18-6433	50-1001	18-7824-2	321129	18-1827	612011	18-1985
31200-ZW1-004	18-15061	501022S	18-8623	324640	18-4578	0100-000	18-2434
31200-ZW9-802	18-6445	53-2009	18-1907	324641	18-4551	0170-000	18-5603-1
31200-ZY6-003	18-6959	53-2018	18-1907	325040	18-99156	0991-110	18-1898
31200-ZY9-003	18-6959	872004 (7QT)	18-9555-4	328725	18-1596	0992-593	18-1939
31200-ZY9A-0031	18-6959	S525009	18-31104	328754	18-2147	0994-000	18-8536
31630-ZW5-003	18-6475	S556003	18-7976	331130	18-3026	50-808011A4	18-5603
31630-ZY6-003	18-6476	S556050	18-42608	331894	18-3566	MARINER	
35655-ZY3-013	18-7657	S556162	18-32152	338485	18-4579	27-99049M	18-74501
35655-ZY3-C01	18-32153	S985009	18-43017	338486	18-4549	MCCULLOCH	
35655-ZY6-013	18-7659	JABSCO		338601	18-1826	1340135	18-5153
35655-ZY9-003	18-7658	1210-0001	18-3081	339720	18-4569	36550135	18-5153
35655-ZZ5-004	18-32153	1210-0003	18-3020	340811	18-1825	38850115	18-5241
36120-ZV5-821	18-6258	124310-46090	18-3075	342370	18-1825	75101A	18-5153
36120-ZV5-822	18-6793	13554-0001	18-3306	346865	18-71340	MERC / EVINRUDE	
36120-ZY3-023	18-6742	14510-46090	18-3075	349354	18-71338	881150K1	18-9895
36120-ZY6-013	18-6745	17636-0001	18-45712	353690	18-1824	MERCUISER	
36120-ZY9-003	18-6743	17935-0001	18-3275	354578	18-1824	13220	18-7751
37500-PNB-003	18-25200	17937-0003	18-3038	354580	18-1822	56045	18-6841
37510-PNB-003	18-25201	18653-0001	18-45713	355169	18-5701	56045	18-6842
37830-PGK-A01	18-7552	18838-0001	18-3046	355209	18-5703	59755	18-6841
41107-ZV5-00-00	18-6165A	18838-0001	18-3060	360347	18-4571	59755	18-6842
41107-ZW1-003ZA	18-6011	18948-0001	18-3047	586768	18-6826	69729	18-6841
41107-ZW1-003ZA	18-6011A	18948-0001	18-3061	5005034	18-5701	69729	18-6842
41107-ZW1-003ZA	18-6241	21676-0001	18-45712	5005831	18-5703	78385	18-5724
41109-ZW1-003	18-6068	22405-0001	18-3076	5007554	18-4571	78477	18-6841
90508-ZW1-003	18-3200	2877-0001	18-3075	5007770	18-6826	78477	18-6842
90752-ZV4-650	18-3268	3101-0000	18-3125	5008967	18-4539	90794	18-6841
90752-ZV5-003	18-3270	4528-0001	18-3079	KAWASAKI		90794	18-6842
90752-ZV7-000	18-3269	4568-0001	18-3075	21163-3715	18-6873	821663	18-6960
90752-ZW1-B02	18-3271	4598-0001	18-3021	21163-3719	18-6873	834832	18-6844
90752-ZW9-A30	18-3022	673-0001	18-3080	21163-3720	18-6904	8216631	18-6960
90752-ZW9-A30	18-3025	673-0003	18-3036	21174-3703	18-6875	11-88462	18-2460
90752-ZY3-003	18-3273	6760-0001	18-3304	K61021-208A	72-5103-2	1389-815396A2	18-7370N
91051-ZW1-003	18-1156	836-0001	18-3078	MALIBU		1389-8490A2	18-7370N
91053-ZW1-003	18-1158	836-0003	18-3037	S556162	18-32152	1389-9350A2	18-7370N
91057-ZW1-003	18-1157	920-0001	18-3077	MALLORY		1389-9562A1	18-7370N
91251-ZW1-003	18-0583	920-0003	18-3038	670	18-26800	14336A15	18-6747
91251-ZW1-B04	18-1820	92700-0060	18-2005	5421	18-35101	14336A15	18-6813
91252-935-004	18-8298	JOHNSON		29349	18-26815	14336A17	18-6747
91252-ZV1-003	18-3288	5036972	18-6945	29716	18-29716	14336A20	18-6813
91252-ZW1-003	18-2002			54212	18-35102	14336A22	18-6747
91253-ZW1-003	18-2054			29440M	18-29720	14336A28	18-6747
91254-ZW1-003	18-0522			4110M	18-34110	14336A6	18-6747
91255-ZW1-003	18-2053						

O.E. #	SIERRA #	O.E. #	SIERRA #	O.E. #	SIERRA #	O.E. #	SIERRA #
14336A6	18-6813	10-28668	18-3229	12-20260	18-2945		
14336A8	18-6813	10-30206	18-2361	12-22388	18-4275	17-45735	18-2152
14336A9	18-6747	10-30720	18-3226	12-23245	18-2948	17-45738	18-2151
14336A9	18-6813	10-31700	18-2163	12-25410	18-0203	17-815953	18-2395
22-88847A1	18-2460	10-31700	18-2163E-9	12-25945	18-4275	17-815953A1	18-2395
26-11973	18-1213	10-32470	18-6245	12-29245	18-4275	17-815953T1	18-2464
26-42750	18-1213	10-36289	18-3729	12-29395	18-4267	17-828507 1	18-15129
26-54799	18-1213	10-43749	18-8410	12-31060	18-7180	17-85056	18-2462
26-97335	18-1213	10-44387	18-8411	12-31211	18-3714	17-8M0020941	18-2357
27-75611A03	18-1254	10-45590	18-2170	12-31211A2	18-3714	17-8M0084681	18-2357
27-864547A02	18-0721	10-67373	18-3197	12-31211A3	18-3714	17-8M0100263	18-2357
27-864547A1	18-0721	10-76156	18-3197	12-31211Q03	18-3714	17-99207	18-2463
27-864547A1	18-0722	10-79953	18-2244	12-31266	18-2340	18-52457	18-2848
27-864549A02	18-0720	10-79953A2	18-2244	12-32733	18-4275	18-524571	18-2848
27-864549A1	18-0720	10-79953Q04	18-2244	12-32834	18-0681	19-14842	18-2465-9
27-864850A02	18-0722	10-79953Q2	18-2244	12-34961	18-9805	19-148421	18-2465-9
30-803097T1	18-8213	10-8053432	18-8402	12-35935	18-0203	19-32652	18-4272
30-803098T1	18-8217	10-8053432	18-8402-1	12-36001	18-4270	19-42682	18-4273
30-803099T1	18-8218	10-805763	18-2361	12-38753	18-4275	19-47579	18-3232
30-803100T1	18-8219	10-8083434	18-8404-1	12-45176	18-4858-9	19-475791	18-3232
3310-806077A2	18-7370N	10-816601	18-3230	12-45810	18-3712	19-815951	18-2466-9
3310-806078A2	18-7370N	10-853163	18-2361	12-49221	18-2948	21-42990A10	18-7817
3310-860070A2	18-7370N	10-86801	18-1706	12-492211	18-2948	21-42990A7	18-7817
3310-861245A1	18-7376N	10-8M0084649	18-2170	12-77674	18-2316	21-42990A8	18-7817
3310-861448A1	18-7375N	10-97934	18-3729	12-77987	18-4220	21-42990A9	18-7817
3310-861448A1	18-7375N	10-97934A1	18-2141	12-77987A1	18-4220	21-806118	18-33800
3310-864941A01	18-7373N	10-98794	18-3231	12-815472	18-0318	21-857005A1	18-7817
3310-864942A01	18-7375N	10-F50109	18-2244	12-824793	18-4275	22-13563A3	18-8076
3310-864943A01	18-7376N	11-13439-1	18-3721	12-835467	18-4220	22-13563A6	18-8091
392-863704T	18-5465	11-20361	18-3722	12-8354671	18-4220	22-13563A7	18-8091
46-807151A12	18-36001	11-21298	18-3721	12-835467Q01	18-4220	22-13563Q3	18-8076
50-60594A	18-6824	11-22178	18-3721	12-855682-2	18-9078	22-13563Q7	18-8091
50-60594A1	18-6824	11-22339	18-3713	12-86645	18-2560	22-13563T3	18-80410-1
50-60594T01	18-6824	11-24648	18-3721	12-866451	18-2560	22-13563T7	18-8091
50-801333980	18-6957	11-29241	18-3721	12-88263	18-1186	22-14213M	18-8075
50-805991	18-6947	11-33962	18-3721	12-8M0042641	18-4267	22-14213Q	18-8075
50-831001562	18-6949	11-34932	18-3720	12-8M2001219	18-0681	22-16610M	18-8084
50-831001961	18-6949	11-34933	18-3721	12-92647M	18-4233	22-16951A1	18-4218
50-854178	18-6957	11-35888	18-3722	12-92721	18-2343	22-16951Q1	18-4218
50-855507	18-6957	11-35921	18-3719	12-93416	18-0681	22-16951T1	18-4218
50-8M8021116	18-6946	11-36084	18-3713	12-934161	18-0681	22-22175	18-7413
65L-13915-00-00	18-79901	11-39823	18-3785	13-888363-2	18-9077	22-30139	18-4263
78403A1	18-6841	11-39907	18-3785	14-17460	18-2298	22-32802	18-4263
78403A1	18-6842	11-42633	18-2346	14-18323	18-2298	22-328021	18-4263
78403A2	18-6841	11-45592	18-3723	14-31210	18-3200	22-328022	18-4263
78403A2	18-6842	11-46355	18-3721	14-34817	18-3788-9	22-32803	18-4264
807252Q4	18-3668	11-47411	18-3719	14-52833	18-2299	22-33198	18-4258
821663A1	18-6960	11-52707	18-3700	14-76281	18-3204	22-33198A1	18-4258
834832T2	18-6844	11-52707A1	18-3701	14-79447	18-2299	22-36305	18-8216
857006A3	18-6844	11-52707A2	18-3701	14-816629	18-3200	22-36305T	18-8216
864308T01	18-1843	11-52707Q1	18-3701	14-816629Q	18-3200	22-36392	18-8111
864591T02	18-1845	11-54034	18-3785	14-F697140	18-3200	22-41622	18-4258
865049T01	18-1843	11-69578	18-3704	15-23097A1	18-2293	22-41622	18-4258
865380A02	18-6747	11-69578A1	18-3702	15-31535A1	18-2284	22-424254	18-8958
865380A05	18-6747	11-69578Q1	18-3702	15-32563A1	18-2282	22-42861	18-4265
865380A13	18-6813	11-69578T1	18-3702	15-33143A1	18-2295	22-428611	18-4265
865380A15	18-6747	11-805092	18-3783	15-35931A1	18-2285	22-46754	18-4258
865380A25	18-6747	11-805092T	18-3783	15-35980A1	18-2292	22-63186	18-8054
865735A02	18-1843	11-805093	18-3786	15-36178A02	18-2293	22-63187	18-8055
88183A12	18-6747	11-826375	18-3719	15-36178A1	18-2293	22-64426	18-4218
88183A12	18-6813	11-8267089	18-3722	15-39899A1	18-2293	22-67892	18-2375
88183A3	18-6747	11-82671015	18-3721	15-42637A1	18-2294	22-67892A05	18-2375
88183A5	18-6813	11-82671127	18-3785	15-45691A1	18-2283	22-67892A06	18-2375
88183A8	18-6813	11-827614	18-3700	15-45811	18-2296	22-67892A1	18-2375
8M0054588	18-5465	11-859116	18-3721	15-47397A1	18-2285	22-67892A1	18-23751-9
92-802837Q1	18-9400-2P	11-859131	18-3783	15-57007A1	18-2295	22-806608A02	18-4226
92-802841A1	18-9400-7P	11-862907	18-3786	15-71013	18-2296	22-806608A1	18-4226
92-857389A1	18-9400-4P	11-863332	18-3728	15-8M0063267	18-2294	22-806926	18-4227
92-858057K01	18-9440-7P	11-88228	18-3703	17-14872	18-2393	22-806926A1	18-4224
		11-95702	18-3721	17-14872A1	18-2463	22-807155	18-4461
		11-97522	18-3713	17-14873	18-2394	22-81042M	18-8075
		11-99298	18-3728	17-14873A1	18-2462	22-816856T2	18-80412
10-14834	18-2375	11-F694188	18-3719	17-30632	18-2357	22-818994	18-8957
10-14834A1	18-2375	12-12577	18-1191	17-35973	18-3227-9	22-8189941	18-8957
10-14834A1	18-23751-9	12-13171	18-4220	17-44166	18-2396	22-841908	18-4263
10-20259	18-2244	12-19183	18-2945	17-44166T1	18-2461	22-861187	18-4265
10-20518	18-2303	12-191832	18-2945	17-44167	18-2397	22-862210	18-4227
10-28634	18-2244	12-191833	18-2945	17-44167A1	18-2397	22-862210A01	18-4224
10-28634A1	18-2244						

MERCURY MARINE

O.E. #	SIERRA #	O.E. #	SIERRA #	O.E. #	SIERRA #	O.E. #	SIERRA #
MERCURY MARINE cont.		23-818471001	18-1316	25-35480	18-7411	26-58094	18-4023
22-87238	18-4218	23-853853	18-1148	25-35984	18-7169	26-58203	18-1211
22-87543	18-4264	23-853853002	18-1148	25-36318	18-7440-1	26-62818	18-0529
22-8M0001721	18-8956	23-853853A1	18-1148	25-36390	18-7410	26-66022	18-0584
23-11992	18-1327	23-85669	18-1317	25-38933	18-7120	26-66303	18-0595
23-11992001	18-1327	23-85677	18-1329	25-39572	18-7151	26-66303A1	18-2627
23-15960	18-1300	23-85684	18-1305	25-39695	18-7464	26-67388	18-0578
23-15961	18-1308	23-85691	18-1333	25-45254	18-7166	26-67863	18-4022
23-1596110	18-1309	23-85698	18-1300	25-45710	18-7198	26-69188	18-2051
23-1596120	18-1341	23-85701	18-1308	25-45711	18-7174	26-69189	18-2052
23-1761515	18-0208	23-85704	18-1309	25-47254	18-7961	26-70019	18-2002
23-1761516	18-0210	23-85705	18-1341	25-47386	18-7411	26-70081	18-2053
23-1761517	18-0212	23-85715	18-1317	25-47632	18-7146	26-72564	18-0518
23-1761518	18-0214	23-85718	18-1316	25-48171	18-7168	26-72564	18-4023
23-1761519	18-0216	23-85726	18-1334	25-48451	18-7159	26-72785	18-0531
23-1761520	18-0218	23-85726001	18-1334	25-53421	18-7177	26-75413	18-0518
23-1761522	18-0222	23-888690	18-9075	25-54029	18-0858	26-75413	18-4023
23-1761523	18-0224	23-888690-1	18-9076	25-54030	18-7467	26-75624	18-0518
23-1761524	18-0226	23-89574	18-2701	25-55801	18-7445	26-75624	18-4023
23-1761526	18-0230	23-89574	18-2701-04	25-59712	18-7177	26-75982	18-4022
23-29804	18-3109	23-90203	18-2336	25-60342A1	18-2291	26-75988	18-4022
23-29804T	18-3109	23-99291	18-2702-04	25-60342A2	18-2291	26-76384	18-2054
23-30617A1	18-2154	23-99291	18-2702-1	25-62384	18-7414	26-76384	18-8347
23-30617A2	18-2154	23-99291T	18-2702-04	25-62700	18-0860	26-76868	18-2002
23-32632	18-3236	23-99291T	18-2702-1	25-62702	18-7413	26-76868A04	18-2645
23-34464	18-1317	24-17057A1	18-1234	25-62704	18-7116	26-76868A1	18-2645
23-37428A1	18-2155	24-17997A1	18-2715	25-62705	18-7105	26-76868A2	18-2645
23-43045	18-0568-9	24-29340A1	18-6506	25-62706	18-7102	26-77066A1	18-2628
23-43293	18-1339	24-29340T1	18-6506	25-62817	18-7175	26-77634	18-2014
23-43293T	18-1339	24-30893	18-2348	25-64068	18-7145	26-79831	18-2055
23-44165	18-4288	24-38191	18-4161	25-64966	18-7415	26-79831	18-2055
23-45736	18-2701	24-46312	18-4252	25-65936	18-7143	26-79831A1	18-2654
23-45736	18-2701-04	24-801879	18-1234	25-67202	18-7107	26-79884	18-2013
23-47392	18-2336	24-801879T	18-1234	25-67675	18-7164	26-79884	18-2026
23-48351	18-1329	24-811554	18-1234	25-69202	18-7419	26-80239M	18-2730-9
23-49168	18-1334	25-16524	18-7421	25-70937	18-7169	26-814622	18-1211
23-49171	18-1333	25-20081	18-7151	25-801334436	18-7168	26-814669A2	18-2635
23-52211	18-1300	25-20195	18-7134	25-803513007	18-76695	26-814754	18-8305
23-52221	18-1308	25-201951	18-7134	25-805726	18-7188	26-81607M	18-2731
23-52224	18-1309	25-20365	18-7135	25-806609	18-7165	26-816464	18-8347
23-52225	18-1341	25-20587	18-7168	25-8071341	18-1508	26-8164641	18-2054
23-52242	18-1329	25-20633	18-7116	25-807149	18-7163	26-8164641	18-8347
23-52261	18-1317	25-20679	18-7153	25-809086	18-0715	26-816575A1	18-2646-1
23-52264	18-1316	25-20826	18-7459	26-36143	18-2094	26-816575A2	18-2599
23-52270	18-1308	25-20863	18-7152	26-36556	18-0563	26-816575A3	18-2646-1
23-52273	18-1309	25-21720	18-7168	26-36557	18-0521	26-816575A4	18-8382
23-52274	18-1341	25-21836	18-7420	26-36557A1	18-3110	26-816575A5	18-2642
23-52928	18-3109	25-22174	18-7116	26-37259	18-2056	26-821309	18-3013
23-55419A1	18-2155	25-23145	18-7114	26-38970	18-3110	26-821310	18-3014
23-61290	18-2701	25-25439	18-7153	26-41131	18-0579	26-821928	18-0585
23-61290	18-2701-04	25-26543	18-0175	26-41132	18-0580	26-821947	18-1233
23-61291	18-2336	25-26722	18-7115	26-41365	18-0581	26-8219471	18-1233
23-67370	18-2349	25-26802	18-7180	26-41365A3	18-2697-1	26-82234M	18-0297
23-67484	18-1340	25-26834	18-7168	26-41953	18-2016	26-82257M	18-0267
23-69884	18-1334	25-26855	18-7155	26-42102	18-2728	26-82389A	18-2003
23-69887	18-1333	25-27018	18-7173	26-421021	18-2728	26-830749	18-2430
23-77631A2	18-2155	25-29439	18-7156	26-43034A1	18-2626	26-830749	18-24301-9
23-79373A1	18-2622	25-29845	18-7103	26-43034A2	18-2626	26-830749A01	18-2725
23-801793	18-1311	25-29976	18-7157	26-43034A3	18-2626	26-84813M	18-0554
23-801803	18-1320	25-30224	18-7173	26-43035	18-0583	26-85090A1	18-2629
23-805041A2	18-2622	25-30271	18-7426	26-43035A4	18-2626	26-85090A2	18-2624
23-806036A1	18-3760	25-30529	18-7171	26-43036	18-0522	26-85107	18-0537
23-807073	18-4288	25-30613	18-7158	26-43993	18-0523	26-854017M	18-0296
23-811858	18-1337	25-31305	18-7172	26-45577	18-2944	26-864319	18-3289
23-811858001	18-1337	25-31534	18-7159	26-455771	18-2944	26-88397A1	18-2644
23-815921A10	18-2353	25-31986	18-7160	26-45587	18-0525	26-88416	18-2094
23-815921A17	18-2353	25-32424	18-7162	26-46021	18-2009	26-888483	18-0564
23-815921A21	18-2353	25-32507	18-7127	26-48443	18-0526	26-892361	18-2009
23-815921A6	18-2353	25-32509	18-7165	26-49131	18-4022	26-89237	18-2056
23-815921A8	18-2353	25-32546	18-7161	26-49154	18-1233	26-89238	18-2014
23-815950	18-2341-1	25-33145	18-7162	26-49947	18-1211	26-89238A1	18-2652
23-8159501	18-2341-1	25-33465	18-7163	26-55682	18-2050	26-89238A2	18-2655
23-815950Q01	18-2341-1	25-33466	18-7164	26-55682A1	18-2653	26-896600	18-0560
23-816583	18-3222	25-33466	18-7164	26-56397	18-0527	26-897153	18-2010
23-818465	18-1300	25-33504	18-7170	26-56788	18-2008	26-897154	18-2006
23-818469	18-1317	25-35027	18-7117	26-56866	18-1230	26-8M0050563	18-4024
23-818469001	18-1317	25-35029	18-7121	26-56868	18-0528	26-90562	18-2011
23-818471	18-1316	25-35276	18-7135	26-58094	18-0518	26-90925	18-0864

O.E. #	SIERRA #	O.E. #	SIERRA #	O.E. #	SIERRA #	O.E. #	SIERRA #
MERCURY MARINE cont.		27-22023	18-2572	27-41246-1	18-3862	27-433373	18-2713
26-94038	18-2007	27-25848	18-2568	27-41382	18-2837	27-433374	18-2713
26-96503	18-2056	27-25849	18-2569	27-41417	18-2710	27-43337A1	18-2713
26-965031	18-2056	27-25851	18-2570	27-414171	18-2710	27-43777	18-2810
26-97530	18-0172	27-26891	18-2800	27-414172	18-2710	27-437771	18-2810
26-97664	18-4024	27-27936	18-0870	27-41418	18-2712	27-437772	18-2810
26-976641	18-4024	27-279361	18-0870	27-414181	18-2712	27-43779	18-2809
26-99325	18-0586	27-30603	18-2914	27-41449	18-0633	27-437791	18-2809
26-F694305	18-2014	27-30604	18-2915	27-414491	18-0633	27-437792	18-2809
26-F697118	18-2076	27-30803	18-0385	27-41475	18-2717	27-43779A87	18-4326
26-F697555	18-2077	27-31402	18-2571	27-414751	18-2717	27-443281	18-2943
27-11338	18-2513	27-31436	18-2837	27-414752	18-2717	27-443282	18-2943
27-11338A85	18-4319	27-31439	18-2836	27-414753	18-2717	27-443283	18-2943
27-11338A88	18-4319	27-31557	18-0385	27-414754	18-2717	27-443284	18-2943
27-11977	18-4408	27-32433	18-2914	27-414755	18-2717	27-45088	18-0373
27-11977A88	18-4388	27-32434	18-2915	27-414756	18-2717	27-45588	18-2622
27-11977A92	18-4388	27-32438	18-2801	27-414757	18-2717	27-45748	18-0385
27-11986	18-3879	27-32769	18-2823	27-414758	18-2717	27-45821	18-2614
27-11987	18-4408	27-32770	18-2824	27-41499	18-2716	27-45821	18-2820
27-11988	18-0311	27-32771	18-2825	27-414991	18-2716	27-46110	18-0942
27-11999	18-2845	27-32816	18-2896-1	27-414992	18-2714	27-46110A1	18-4353
27-13218	18-3877	27-32910	18-0356	27-414993	18-2714	27-46110A2	18-4353
27-13461A88	18-4340	27-33121	18-2830-1	27-414994	18-2714	27-46110A72	18-4353
27-13461A89	18-4340	27-33179	18-2917	27-414995	18-2714	27-46233	18-2836
27-13461A90	18-4340	27-331791	18-2552	27-41499A87	18-4334	27-46401	18-2830-1
27-13461A99	18-4340	27-331792	18-2552	27-41610	18-0467	27-46401A1	18-4396
27-13687	18-3877	27-33395	18-2949	27-41636A1	18-4381	27-46820	18-0418
27-13709	18-3878	27-33395A1	18-4394	27-41670-3	18-0336	27-46820A1	18-4397
27-13709T	18-3878	27-33395A2	18-4394	27-41670-5	18-0336	27-47453	18-3881
27-13865	18-1237	27-33918	18-0398	27-41811	18-0672	27-47453A1	18-4389
27-138651	18-1237	27-33956	18-0327	27-41812	18-2554	27-47510	18-2553
27-13937-6	18-0320	27-34041	18-0347	27-41812Q	18-2554	27-47510Q	18-2553
27-139581	18-2621	27-34042	18-0346	27-41813	18-0897	27-47590	18-2831
27-14241	18-0322	27-34043	18-2845	27-41899M	18-2785	27-475901	18-2831
27-14247	18-0405	27-34208	18-0328	27-42178	18-0633	27-47644	18-0342
27-142471	18-61513	27-34209	18-0329	27-42206	18-2559	27-47644	18-0342
27-14247T1	18-61513	27-34213	18-0889	27-42457A1	18-4377	27-476441	18-0342
27-14250	18-0976	27-34213A1	18-4375	27-42631	18-2919	27-48042	18-0885-1
27-14318 3	18-0323	27-34213A2	18-4375	27-426311	18-2919	27-48043	18-2832-1
27-14318-2	18-0323	27-34216	18-0887	27-42744	18-3879	27-48043	18-2832-1-9
27-146972	18-0644	27-34273	18-3880	27-43004009	18-2741	27-480431	18-2832-1
27-14697A87	18-4339	27-342731	18-3880	27-430041	18-2741	27-480431	18-2832-1-9
27-14765	18-25001	27-34274	18-3881	27-430042	18-2741	27-48164	18-2802
27-14901	18-0466	27-34278	18-3876	27-430043	18-2741	27-481641	18-2802
27-14901A1	18-0466	27-34486	18-0874	27-430045	18-2741	27-48330	18-3876
27-15172	18-0324	27-344861	18-0874	27-430047	18-2741	27-48399	18-0462
27-15172-3	18-0324	27-344863	18-0874	27-43004A86	18-4336	27-48713	18-0982-1
27-151724	18-0324	27-34502	18-0905	27-43004A90	18-4336	27-48818	18-2844
27-167371	18-0645	27-34614	18-2570	27-43004A99	18-4336	27-488181	18-2844
27-17145	18-0868	27-34891	18-0874	27-430051	18-2740	27-48818Q1	18-2844
27-17467	18-0664	27-34895	18-0976	27-430052	18-2740	27-49104	18-3877
27-18272	18-0881-1	27-34896	18-0891	27-430053	18-2740	27-49107	18-0348
27-18307-1	18-0643	27-34897	18-0891	27-430055	18-2740	27-49109	18-0980
27-183076	18-0643	27-34898	18-0876	27-430056	18-2740	27-49110	18-0903
27-187851	18-3861	27-35380	18-0893	27-430057	18-2740	27-49121	18-0464
27-187853	18-3861	27-35898A2	18-4395	27-43006-2	18-0339	27-49814	18-0467
27-18785T	18-3861	27-35898A3	18-4395	27-430066	18-0339	27-49936	18-0346
27-18786-1	18-3871	27-35898A4	18-4395	27-43007	18-0670	27-49953	18-0887
27-188891	18-0624	27-35982	18-2840	27-430073	18-0670	27-49955	18-0905
27-18937	18-3828	27-35996	18-2556	27-430075	18-0670	27-49955	18-2833
27-18937M	18-3828	27-35996	18-2617	27-43008	18-0341	27-52076	18-2833
27-19050	18-0642	27-35996A1	18-2556	27-430082	18-0341	27-52144	18-0466
27-190502	18-0642	27-35996A1	18-2617	27-430083	18-0341	27-52145	18-0347
27-190503	18-0642	27-37724	18-0879	27-430085	18-0341	27-52184	18-0874
27-190505	18-0642	27-37725	18-0103	27-430086	18-0341	27-52202	18-2845
27-190506	18-2735	27-37816	18-2507	27-43033	18-2564	27-52364	18-2946
27-19138	18-3804	27-37976	18-0988	27-430333	18-2564-1	27-524572	18-2848
27-19138M	18-3804	27-38501	18-0879	27-430331	18-2564	27-52546	18-2896-1
27-19202	18-2559	27-385011	18-0879	27-430334	18-2564-1	27-52550	18-0348
27-19204-2	18-2558	27-39164	18-3881	27-43034	18-2563	27-52571	18-0403
27-19206	18-0633	27-39316	18-0371	27-430341	18-2563	27-52579	18-0372
27-192061	18-0633	27-39401	18-0333	27-43047	18-2565	27-52584	18-2830-1
27-19315	18-3877	27-39402	18-0334	27-430471	18-2565	27-52892	18-0133
27-194541	18-2593	27-39623	18-2827	27-430472	18-2565	27-52893	18-2500
27-19551	18-2824	27-39625	18-2828	27-43186A1	18-4381	27-53045	18-2917
27-19552	18-2841	27-39915	18-2819-1	27-43337	18-2713	27-530451	18-2917
27-19553	18-2823	27-39923	18-1210-1	27-433371	18-2713	27-53354A1	18-2912-1
27-19701	18-0622	27-41245-1	18-3872	27-433372	18-2713	27-53650	18-4398
							18-2514

O.E. #	SIERRA #	O.E. #	SIERRA #	O.E. #	SIERRA #	O.E. #	SIERRA #
MERCURY MARINE cont.		27-64818T1	18-2614	27-73665	18-0133	27-8127551	18-2611
27-53863	18-2807	27-64857	18-0131	27-73666	18-0685	27-812755A01	18-2611
27-54014	18-2620	27-64940	18-2807	27-73814	18-0928-1	27-8127754	18-2610
27-54014	18-2847	27-65184	18-0465	27-738141	18-0928-1	27-8127755	18-2611
27-54014A1	18-2620	27-65577	18-0357	27-73866	18-0183-1	27-812867	18-2749
27-54014A1	18-2847	27-65744	18-0129	27-74264	18-3878	27-8128671	18-2749
27-54014Q1	18-2620	27-657441	18-0129	27-74264A1	18-4382	27-8128672	18-2729
27-54014Q1	18-2847	27-657442	18-0129	27-74511	18-2504	27-812867A91	18-4337
27-54014T1	18-2620	27-657443	18-0129	27-74830	18-2843	27-812867A96	18-4337
27-54014T1	18-2847	27-65788	18-2806	27-74830A1	18-4382	27-812867A97	18-4337
27-54529	18-0980	27-66101	18-2835	27-74830A3	18-4382	27-813859	18-0646
27-54529A1	18-4378	27-66102	18-0912	27-75450	18-0365	27-81417M	18-0292
27-54566	18-0183-1	27-661021	18-0912	27-75483	18-0611	27-814210	18-0463
27-54566A1	18-4399	27-66358	18-2837	27-75611	18-3876	27-81421M	18-0294
27-55279	18-2838	27-66847	18-0914	27-75611001	18-3876	27-814703	18-2815
27-552791	18-2838	27-67208	18-2513	27-75611A1	18-4392	27-814754A00	18-4338
27-55306A72	18-4355	27-67275	18-0359	27-75611A2	18-4392	27-815528	18-0680
27-55306A73	18-4355	27-672751	18-0359	27-75646	18-3883	27-815791A00	18-64217
27-55306A74	18-4355	27-67389	18-0864	27-75647	18-3883	27-815791A92	18-4359
27-55306A75	18-4355	27-67738	18-2501	27-75648	18-0410	27-815792A90	18-4359
27-55308	18-0940	27-67751	18-2509	27-75791	18-2800	27-815809A90	18-4359
27-55810	18-0894	27-68714	18-4380	27-757911	18-2800	27-815810A90	18-4359
27-558101	18-0894	27-68714A6	18-4380	27-75909	18-0369	27-816460	18-3879
27-56110	18-3883	27-68714A7	18-4380	27-75952	18-0151	27-817277	18-2566
27-56173	18-0352	27-68715	18-0956-1	27-76401	18-2504	27-8172771	18-2566
27-56304	18-0982-1	27-69238	18-2835	27-76589	18-0139	27-817533	18-0384
27-56859	18-0898	27-692381	18-2835	27-76589A77	18-4357	27-818188	18-1231
27-56870A1	18-0407	27-69524	18-0918	27-76589A78	18-4357	27-8181881	18-1231
27-56880	18-0147	27-695241	18-0918	27-76589A79	18-4357	27-818832	18-2849-1
27-56883	18-0889	27-695242	18-0918	27-76636	18-0151	27-81987	18-4698
27-56884	18-0357	27-69525	18-0131	27-76862	18-0932	27-81987M	18-4698
27-58025	18-7143	27-695251	18-0131	27-768621	18-0932	27-81987M	18-46981-9
27-58764	18-0353	27-695252	18-0131	27-76952	18-0101	27-822189	18-0345
27-60208	18-2834	27-69659	18-2800	27-77417	18-2841	27-822217	18-99155
27-60286	18-2512	27-70142	18-0360	27-78026	18-2507	27-822844-1	18-3864
27-60310	18-2504	27-70143	18-0994	27-78027	18-0940	27-823142	18-0378
27-60317	18-0904	27-701431	18-0994	27-78028A78	18-4355	27-823142 2	18-0378
27-60475	18-2573	27-70143B1	18-0994	27-78035	18-2836	27-824326	18-1238
27-60476	18-2574	27-70335	18-0922	27-78068	18-2503	27-824326002	18-0487
27-60476A72	18-4356	27-703351	18-0922	27-78069	18-0934-1	27-8243261	18-0487
27-60476A73	18-4356	27-70905	18-0158	27-78087	18-2837	27-824853	18-0835
27-60476A74	18-4356	27-72098	18-4380	27-78246	18-0135	27-8248531	18-0835
27-60476A75	18-4356	27-72142	18-2573	27-782461	18-0135	27-825032	18-3845
27-60477	18-2839	27-721421	18-2573	27-78409	18-0371	27-825482	18-3827
27-60479	18-2835	27-72479	18-4366	27-78410	18-0372	27-8254821	18-3827
27-60715	18-0354	27-72479A5	18-4366	27-78411	18-0373	27-827154	18-61319
27-60721	18-0905	27-72479T	18-4366	27-78623	18-0139	27-827284	18-2721
27-60945	18-0912	27-72486	18-0942	27-78690	18-0936	27-828292	18-0641
27-61224	18-3877	27-72486A32	18-4353	27-79373	18-2622	27-828553	18-0319
27-61782	18-0403	27-72486A76	18-4353	27-79650	18-0103	27-832933006	18-2739
27-62386	18-0182	27-72486A78	18-4353	27-796501	18-0103	27-8329331	18-2739
27-62860	18-0988	27-72486A79	18-4353	27-79986	18-3878	27-8329332	18-2739
27-628601	18-0988	27-72487	18-2507	27-801853	18-4387	27-8329333	18-2739
27-63309	18-2572	27-72496	18-0103	27-801855	18-4365	27-8329334	18-2739
27-64173	18-2835	27-72505	18-2500	27-803508	18-3844	27-8329335	18-2739
27-64203	18-0107	27-72506	18-2807	27-803508017	18-60917	27-834952001	18-60919
27-64203A73	18-4351	27-72507	18-2574	27-805215	18-0916	27-835427003	18-60918
27-64203A74	18-4351	27-72508	18-0944	27-8052151	18-0916	27-835427A04	18-64221
27-64203A75	18-4351	27-72509	18-2839	27-805396	18-0740-1	27-83899M	18-3828
27-64204	18-0944	27-72510	18-0107	27-805403A1	18-0404	27-83940M	18-0380
27-64692	18-0356	27-72622	18-3881	27-805722A1	18-0403	27-845628	18-1232
27-64763	18-3883	27-72627	18-0153	27-806452	18-0347	27-84733M	18-3804
27-64763A2	18-4391	27-72637	18-0868	27-807218	18-0928-1	27-850283	18-2737
27-64798	18-0407	27-72779	18-0916	27-807473A1	18-0488	27-850318	18-3675
27-64818	18-2614	27-72780	18-0386	27-807982	18-0994	27-8503181	18-3675
27-64818	18-2820	27-72915	18-0371	27-8079821	18-0994	27-850470	18-3887
27-64818A1	18-2614	27-72916	18-0372	27-807982B	18-0994	27-850836001	18-60916
27-64818A1	18-2820	27-72917	18-0373	27-81031M	18-0232	27-85087	18-2561
27-64818A2	18-2619-1	27-72918	18-2837	27-81084	18-2946	27-852957	18-7690
27-64818A2	18-2743	27-72919	18-2836	27-810846	18-1239	27-853702005	18-60920
27-64818A20	18-2614	27-73377	18-2804	27-810846T	18-1239	27-85487	18-2507
27-64818A20	18-2820	27-733771	18-2804	27-811546	18-3874	27-85488	18-0940
27-64818A3	18-2619-1	27-73397	18-0101	27-811547	18-3887	27-854881	18-0940
27-64818A3	18-2619-1	27-73440A76	18-4357	27-811566	18-1232	27-854882	18-0940
27-64818A4	18-2614	27-73645	18-0926	27-811572	18-0468	27-85489-2	18-0105
27-64818A4	18-2820	27-73645A32	18-4354	27-811588	18-25002	27-85490-2	18-2805
27-64818Q4	18-2614	27-73645A76	18-4354	27-812712	18-0403	27-85491	18-0942
27-64818Q4	18-2820	27-73645A87	18-4354	27-812755	18-2610	27-85491-2	18-0942

O.E. #	SIERRA #	O.E. #	SIERRA #	O.E. #	SIERRA #	O.E. #	SIERRA #
MERCURY MARINE cont.		27-89937	18-0385	27-995061	18-0667	31-30894A1	18-1156
27-854911	18-0942	27-8M0027781	18-0384	27-99757	18-2909	31-30894A5	18-1182
27-854913	18-0942	27-8M0049045	18-3877	27-99776	18-2508-1	31-30895	18-1157
27-85491A90	18-4325	27-8M0050224	18-0465	27-997761	18-2508-1	31-30895T	18-1157
27-85492-2	18-0137	27-8M0077608	18-0905	27-99777	18-2833	31-30956	18-1158
27-85493	18-2500	27-8M0090319	18-2914	27-997771	18-2833	31-30956T	18-1158
27-85494	18-2807	27-8M2021920	18-0398	27-997772	18-2833	31-32573A1	18-1142
27-85495	18-2574	27-90430	18-2803	27-99777A1	18-4367	31-32575A1	18-1179
27-854951	18-2574	27-904301	18-2803	27-99960	18-0389	31-32575T1	18-1179
27-854952	18-2574	27-90458	18-0411	28-43037	18-3293	31-32898	18-1115
27-85496	18-0944	27-90458A1	18-0411	28-81603M	18-3294	31-32898T	18-1115
27-854961	18-0944	27-90484	18-2502	28-81912M	18-3305	31-33138A1	18-1193
27-85497	18-2839	27-904841	18-2502	28-83444M	18-3300	31-35246	18-1120
27-854971	18-2839	27-90484A32	18-4317	28-83701M	18-3305	31-35928A1	18-1159
27-854972	18-2839	27-90484A86	18-4317	28-8M0058389	18-2375	31-35928T1	18-1159
27-85498	18-0107	27-90484A88	18-4317	29-47270	18-4036	31-35988A12	18-1160
27-85498-1	18-0107	27-90556	18-2554	29-71422	18-4037	31-35988A2	18-1160
27-85608	18-2914	27-91831	18-0464	29-88258	18-1186	31-35990A1	18-1161
27-85609	18-2914	27-91892	18-0185	30-17927	18-1155	31-36387A1	18-1143
27-856091	18-2915	27-92166	18-3878	30-20066	18-1151	31-38356A1	18-1162
27-85610	18-2826	27-921661	18-3878	30-20464	18-1153	31-42647	18-1117
27-856101	18-2826	27-92331	18-2717	30-20839	18-1190	31-42647A1	18-1117
27-85653	18-0946	27-92332	18-2716	30-20839T	18-1190	31-42677A1	18-1118
27-85653-1	18-0946	27-92648M	18-2787	30-20861	18-1398	31-43012A1	18-1195
27-85653A32	18-4356	27-92720	18-0954	30-23679	18-1152	31-44348001	18-2748
27-85653A79	18-4356	27-93214	18-0324	30-35914	18-1155	31-47245A1	18-4038
27-85653A87	18-4356	27-93536	18-2501	30-36056	18-2101	31-48939A2	18-1144
27-856704	18-2826	27-935361	18-2501	30-36418	18-2101	31-48941A1	18-1163
27-856705	18-0113-1	27-94914	18-0386	30-41421	18-1345	31-54036A1	18-1126
27-856730	18-0946	27-94915	18-0916	30-43011	18-1346	31-54038A1	18-1127
27-85817A1	18-0153	27-94996	18-2619-1	30-43011T	18-1346	31-54042T	18-1180
27-858524	18-2915	27-94996	18-2743	30-49313	18-1153	31-54928	18-1356
27-858524	18-2915	27-94996A1	18-2743	30-54215	18-1153	31-55332A1	18-4038
27-858935	18-0649	27-94996A1	18-2743	30-562540A3	18-21005	31-58859A1	18-4038
27-85978	18-2710	27-94996A2	18-2619-1	30-60794A2	18-2100	31-61100A1	18-1165
27-85979	18-2712	27-94996A2	18-2619-1	30-60794A2	18-21001	31-61424A2	18-4038
27-860231	18-0672	27-94996A2	18-2743	30-60794A2	18-2100K	31-62596A1	18-4038
27-860232	18-2849-1	27-94996A20	18-2619-1	30-60794A4	18-2100	31-62799A1	18-1111
27-860233	18-0897	27-94996A3	18-2743	30-60794A4	18-21001	31-63075A1	18-4038
27-863724	18-0897	27-94996Q2	18-2619-1	30-60794A4	18-2100K	31-67526	18-1194
27-863725	18-0672	27-94996Q2	18-2743	30-62699	18-1190	31-67526A1	18-1194
27-8637251	18-0672	27-94996T2	18-2619-1	30-63326	18-1153	31-67526A2	18-1194
27-863726	18-2849-1	27-96171	18-2505	30-63326T	18-1153	31-73363	18-1122
27-863891	18-2736	27-961711	18-2505	30-63742	18-1154	31-73363T	18-1122
27-863893	18-2736	27-96278	18-2808	30-63742T	18-1154	31-74248	18-1196
27-863895	18-2736	27-96286	18-2713	30-67923	18-1345	31-74248T	18-1196
27-87105	18-2849-1	27-96429	18-1204-1	30-67923T	18-1345	31-78172A1	18-1166
27-871051	18-2849-1	27-96429	18-1204-1-9	30-72961	18-1398	31-803090T1	18-8208
27-87396	18-2502	27-96440	18-2508-1	30-803097T1	18-2601-1	31-803090T1	18-1170
27-87707	18-0948	27-96483	18-2810	30-803098T1	18-8205	31-814337A1	18-1194
27-879150139	18-3874	27-96485	18-2809	30-803099T1	18-8206-1	31-821146A1	18-1194
27-879150140	18-3879	27-96542-1	18-3863	30-803100T1	18-8212-1	31-828437A2	18-1173
27-879150141	18-3887	27-96761	18-2510	30-862540A0	18-21005	31-828439A2	18-1197
27-88046	18-0950	27-97529	18-3877	30-862540A0	18-21005K	31-86748A1	18-1129
27-880729	18-0791	27-97542	18-0113-1	30-862540A0	18-21006	31-88269T	18-1347
27-881715	18-0322	27-97863	18-0881-1	30-862540A3	18-21005K	31-8M0045428	18-1194
27-883964	18-0405	27-98185	18-2807	30-862540T1	18-21006	31-8M0045430	18-4039
27-883964T	18-0405	27-981851	18-2807	30-862540T1	18-21005K	31-8M0103473	18-1129
27-88449	18-2504	27-9818512	18-2807	30-862540T1	18-21006	31-8M0103474	18-1126
27-88449A32	18-4357	27-981853	18-2807	30-862540T1	18-21006	31-92366	18-1150
27-88449A80	18-4357	27-98769	18-0970	30-879194A01	18-21005	31-92366A1	18-1150
27-88451	18-0139	27-987691	18-0970	30-879194A01	18-21005K	31-F506818	18-1129
27-884511	18-0139	27-98823	18-0388	30-879194A02	18-21006	31-F523058	18-1158
27-88907	18-0952	27-988231	18-0388	30-879194A02	18-21001	31-F694057	18-1117
27-892157	18-2714	27-98990M	18-3828	30-879194A02	18-21001	31-F84901	18-1162
27-892158	18-2717	27-99173-2	18-2511	30-88957	18-1155	31-M8004528	18-1194
27-89221	18-0384	27-99176	18-2506-1	30-88957A1	18-1155	32-14358	18-2746
27-89221A32	18-4319	27-991762	18-2506-1	30-88957T	18-1155	32-14358T	18-2746
27-89221A84	18-4319	27-991763	18-2506-1	31-12576	18-1112	32-16011	18-70955
27-89221A85	18-4319	27-991764	18-2506-1	31-12578	18-1112	32-16012	18-70956
27-89221A88	18-4319	27-99177	18-2503	31-12578T	18-1113	32-16021	18-70925
27-89656	18-2555	27-991771	18-2503	31-14358001	18-2746	32-160211	18-70925
27-896561	18-2555	27-991772	18-2503	31-17514	18-1194	32-32461	18-3601
27-89656A1	18-4381	27-99326	18-2562	31-17514A1	18-1194	32-32461A1	18-3601
27-89657	18-0111	27-993261	18-2562	31-17514A2	18-1194	32-38377	18-2160
		27-99506	18-0667	31-17514A2	18-4039	32-4172533	18-3602
				31-29982	18-1115	32-43437	18-3603
						32-44348	18-2748

O.E. #	SIERRA #	O.E. #	SIERRA #	O.E. #	SIERRA #	O.E. #	SIERRA #
MERCURY MARINE cont.		32-88005	18-2110	35-802893Q4	18-7983-1	35-8M0008397	18-7914
32-44348T	18-2748	32-88006	18-2111	35-80365M	18-7713	35-8M0020349	18-7981
32-45327	18-2110	32-883702K	18-7879-1	35-803897Q1	18-7784	35-8M0064104	18-7914
32-45959	18-2111	32-883702Q	18-7879-1	35-805369	18-7944	35-8M0079962	18-79911
32-45973	18-2105	32-887952	18-70952	35-805369	18-7945	35-8M0082290	18-79912
32-45974	18-2106	32-89653	18-70704	35-8053691	18-7845	35-8M0103095	18-7919
32-47373	18-2103	32-897181	18-70934	35-8053691	18-7944	35-93568	18-7717
32-47640	18-70931	32-897491	18-70943	35-8053691	18-7945	39-15320M	18-3976
32-48131	18-71218	32-8M0062309	18-3602	35-805369A4	18-7848-1	39-15320T	18-3976
32-48132	18-71218	32-8M0062614	18-75100	35-805809	18-7871	39-15322M	18-3978
32-48418	18-2126	32-8M0062665	18-75125	35-805809T	18-7871	39-17464	18-3937
32-52481	18-70930	32-8M0071007	18-70931	35-806771	18-7845	39-17465	18-3938
32-52951A1	18-2126	32-8M0090859	18-3603	35-806771	18-7944	39-18487A12	18-3924
32-5346170	18-75125	32-90949	18-2761	35-806771	18-7945	39-18653A1	18-3967
32-54236	18-3220	32-90949T	18-2761	35-807172	18-7844	39-18653A12	18-3966
32-55816	18-2107	32-95858	18-2435	35-807172	18-7845	39-18653A2	18-3968
32-59841	18-2108	32-95859	18-2436	35-807172	18-7944	39-18939M	18-3977
32-59841A1	18-2108	32-96246	18-70958	35-807172	18-7945	39-19721A1	18-4020
32-59842	18-2109	32-96246A1	18-70958	35-807172A4	18-7848-1	39-19721A2	18-4021
32-66073	18-2103	32-96246A4	18-70958	35-807172A4	18-7983-1	39-19721A6	18-4019
32-68676	18-2103	32-96879	18-70931	35-808275	18-7873	39-34479	18-3942
32-71613	18-70928	32-97153A1	18-2110	35-809097	18-7919	39-34988	18-3937
32-73004	18-2103	32-97154A1	18-2111	35-809099	18-7920	39-45155A12	18-3902
32-73005	18-2109	32-99902	18-2136	35-809100	18-7929	39-45204A12	18-3916
32-73123	18-2108	32-99902-1	18-2114	35-813405	18-7964-1	39-48344	18-3939
32-73794	18-70929	32-99903	18-2137	35-813405A1	18-7964-1	39-48345	18-3938
32-73795	18-70927	32-99903-1	18-2115	35-815419	18-7964-1	39-58096	18-3942
32-73796	18-70926	32-99904	18-2116	35-816296	18-7829	39-65153	18-3937
32-79431	18-2103	32-99904Q	18-2116	35-816296-1	18-7830	39-66217	18-3939
32-802885Q	18-7876-1	35-11004A1	18-7784	35-8162961	18-7830	39-67119	18-3942
32-8066351	18-70938	35-134301	18-7830	35-816296B1	18-7830	39-67123	18-3937
32-8066361	18-70939	35-14571A1	18-7967	35-816296B2	18-7830	39-67126	18-3938
32-8066362	18-70946	35-16248	18-7712	35-816296K03	18-7829	39-67127	18-3940
32-806825	18-71337	35-16494	18-7829	35-816296Q	18-7829	39-67132	18-3942
32-806856	18-70935	35-164941	18-7830	35-816296Q2	18-7830	39-74381A1	18-3928
32-807407	18-70949	35-17808A1	18-7967	35-816296T	18-7829	39-75422	18-3928
32-807458T	18-2770	35-184585	18-7968	35-816296T1	18-7830	39-75609	18-3944
32-8078961	18-70951	35-18458A2	18-7967	35-816396Q1	18-7830	39-78811A12	18-3916
32-8078962	18-70951	35-18458A3	18-7967	35-8226267	18-7906-1	39-78816A12	18-3902
32-808033	18-70948	35-18458Q3	18-7967	35-822626K04	18-7914	39-78918A4	18-3922
32-8080441	18-70953	35-18458Q4	18-7968	35-822626Q03	18-7913	39-81096M	18-3986
32-814384	18-3221	35-49088	18-7860	35-822626Q04	18-7914	39-813011A12	18-3927
32-858104K08	18-8024EP-2	35-49088A2	18-7860	35-822626Q1	18-7913	39-815267A4	18-3925
32-858104Q08	18-8024EP-2	35-49088Q2	18-7860	35-822626Q15	18-7906-1	39-817096A16	18-3919
32-858105K08	18-8025EP-2	35-52456	18-7944	35-822626Q2	18-7914	39-817096A26	18-3920
32-858105Q08	18-8025EP-2	35-52456	18-7945	35-822626T2	18-7914	39-817096A6	18-3918
32-858109K12	18-8016EP-2	35-52456A1	18-7848-1	35-822626T7	18-7906-1	39-822321A12	18-3982
32-858109K12	18-8016S-1	35-52456A1	18-7983-1	35-853333	18-7997	39-822321A2	18-3984
32-858109Q12	18-8016EP-2	35-53336	18-7859	35-853333T	18-7997	39-824905A12	18-3982
32-858114K08	18-8012EP-2	35-53336Q	18-7859	35-864572	18-7721	39-826293A12	18-4051
32-858114Q08	18-8012EP-2	35-55501	18-7845	35-866171A01	18-7977	39-826297A12	18-4052
32-860089	18-70954	35-55501	18-7944	35-866340K01	18-7824-2	39-827179A12	18-4050
32-8600891	18-70954	35-55501	18-7945	35-866340Q	18-7824-2	39-83196M	18-3992
32-860144	18-70940	35-55501A1	18-7848-1	35-866340Q02	18-7824-2	39-85636A4	18-3923
32-860205	18-70951	35-55501A1	18-7983-1	35-866340Q02	18-7824-2	39-88392	18-3917
32-860220	18-3221	35-57250	18-7845	35-866340Q02	18-7876-1	39-88392A12	18-3917
32-86036	18-2103	35-57250	18-7944	35-866340Q03	18-7824-2	39-93481A12	18-3921
32-86036A1	18-2103	35-57250	18-7945	35-866340Q03	18-7876-1	39-96170A12	18-3979
32-86036Q	18-2103	35-57250A1	18-7848-1	35-866594K01	18-7596	39-96170A4	18-3981
32-861127	18-2435	35-60494	18-7983-1	35-877565T	18-7714	39-97125	18-3939
32-861128	18-2436	35-60494	18-7944	35-877565T1	18-7714	40-52035	18-4294
32-861590A05	18-71337	35-60494	18-7945	35-877761K01	18-7758	43-17064A3	18-2407
32-861590A1	18-71337	35-604941	18-7845	35-877761Q01	18-7758	43-18410A2	18-2201
32-861590A2	18-71337	35-604941	18-7944	35-877767K01	18-7921	43-18411A2	18-2201
32-861635	18-44092	35-604941	18-7945	35-877768K01	18-7914	43-42933A2	18-2407
32-862124	18-70947	35-60494A1	18-7848-1	35-877769K01	18-7918	43-42933A3	18-2407
32-862139	18-70945	35-60494A1	18-7983-1	35-87946A3	18-7802	43-45814A5	18-2203
32-864588	18-2137	35-60494A4	18-7845	35-87946Q3	18-7802	43-55765A2	18-2203
32-864589	18-2136	35-60494A4	18-7848-1	35-87946Q4	18-7802	43-55765A3	18-2203
32-864959	18-2115	35-60494A4	18-7983-1	35-879885T	18-7718	43-55766A2	18-2205
32-864960	18-2114	35-802884Q	18-7879-1	35-880084T01	18-7523	43-55766A3	18-2205
32-865672070	18-75125	35-802885Q	18-7824-2	35-883701K01	18-7918	43-55778A3	18-2205
32-87116	18-70925	35-802886Q	18-7875	35-884380T	18-7981	43-59832A2	18-2201
32-87117	18-70932	35-802893A4	18-7983-1	35-886638	18-7948	43-59832A4	18-2201
32-871171	18-70932	35-802893Q	18-7844	35-888289T2	18-7936	43-61027	18-2200
32-87234	18-2112	35-802893Q	18-7944	35-892665	18-7715	43-75325A2	18-2204
32-87235	18-2113	35-802893Q	18-7945	35-896247	18-7999	43-75325A3	18-2204
		35-802893Q4	18-7848-1	35-896546T	18-7921	43-803069T1	18-2369

O.E. #	SIERRA #	O.E. #	SIERRA #	O.E. #	SIERRA #	O.E. #	SIERRA #
MERCURY MARINE cont.		46-48746A3	18-3118	47-59362A4	18-3216	50-66015T1	18-5642
43-803071T1	18-2368	46-48747A3	18-3517	47-59362Q08	18-3318	50-67341	18-5602
43-803079T1	18-2404	46-48748A1	18-3421	47-59362T	18-3087	50-69865A1	18-5903
43-803091T1	18-2405	46-57234A1	18-3417	47-65957	18-3039	50-72467	18-5636
43-803101T1	18-2259	46-57234A3	18-3517	47-65958	18-3052	50-72550A2	18-5907
43-803102T1	18-2358	46-58618A4	18-3517	47-65960	18-3017	50-73521	18-5605
43-803103T1	18-6351K	46-59112A2	18-3600	47-68988	18-3054	50-73521T	18-5605
43-803104T1	18-6350K	46-60366A1	18-3507	47-72774A89	18-3155	50-76965A3	18-5908
43-803105T1	18-6353K	46-60367A4	18-3517	47-80395M	18-3072	50-76965A4	18-5911
43-803106T1	18-6352K	46-63450A2	18-3600	47-81242M	18-3063	50-76967A1	18-5908
43-803112T1	18-2257	46-64141A1	18-3116	47-81423M	18-3069	50-76967A4	18-5908
43-803114T1	18-2258	46-64141A11	18-3517	47-81604M	18-3067	50-77141	18-5608
43-803116T1	18-2256	46-65498A1	18-3422	47-82824M	18-3069	50-77141	18-5608
43-803118T1	18-2363	46-68390A1	18-3422	47-84027M	18-3074	50-77328A1	18-6275
43-803119T1	18-2364	46-69222A3	18-3517	47-84027T	18-3074	50-77328A3	18-5911
43-803120T1	18-2365	46-70941A3	18-3446	47-84797M	18-3067	50-77328A3	18-6275
43-803615T1	18-1564	46-72774A11	18-3600	47-85089-3	18-3057	50-79472	18-5608
43-803615T2	18-1551	46-72774A32	18-3600	47-85089T7	18-3215	50-79472	18-5608
43-803615T2	18-1564	46-73640A1	18-3423	47-85460	18-3017	50-79472 1	18-5608
43-821823A1	18-6350	46-73640A2	18-3323	47-862232A2	18-3016-1	50-79472 1	18-5608
43-823072A2	18-2407	46-73802A2	18-3416	47-89980	18-3054	50-79604A3	18-5907
43-828072A2	18-2206-1	46-73802A3	18-3517	47-89981	18-3039	50-804312T1	18-6425
43-828072A3	18-2360	46-73804A1	18-3414	47-89982	18-3052	50-805833	18-6870
43-828073A1	18-2206-1	46-73804A3	18-3517	47-89982T1	18-3252	50-805833T	18-6870
43-828073A1	18-2408	46-73823A7	18-3600	47-89983	18-3007	50-806963A4	18-5919
43-828175A1	18-1566	46-73842A2	18-3422	47-89983Q1	18-3207	50-806964A2	18-6275
43-850036	18-1560	46-77177A1	18-3424	47-89983T	18-3007	50-806964A3	18-6275
43-850036T	18-1560	46-77177A3	18-3324	47-89983T2	18-3207	50-806964A4	18-6275
43-853640A2	18-6350	46-77516A1	18-3422	47-89984	18-3017	50-806965A2	18-5919
43-853641A2	18-6351	46-77516A3	18-3322	47-899842	18-3017	50-806965A4	18-5919
43-853642A2	18-6352	46-77822A1	18-3118	47-899844	18-3017	50-807904A1	18-6275
43-853643A2	18-6353	46-78400A1	18-3416	47-89984T3	18-3017	50-808011A05	18-5908
43-878072A3	18-2406	46-78400A2	18-3316	47-89984T4	18-3017	50-808011A1	18-5908
43-878087A2	18-2206-1	46-78400A2	18-3517	47-8M0100526	18-3265	50-808011A3	18-5908
43-878087A2	18-2360	46-8037502	18-43212	47-95289	18-45312	50-808011A4	18-5603-1
43-878087A2	18-2406	46-803750A02	18-43212	47-952892	18-45312	50-808011A4	18-5908
43-878087A4	18-2407	46-803750A03	18-48317	47-95611M	18-3063	50-812428A3	18-5913-1
43-881260A3	18-1550	46-807151A14	18-3150	47-96305M	18-3073	50-812428A3	18-6275
43-92320	18-2409	46-807151A7	18-3150	47-96619M	18-3074	50-812604A2	18-5913-1
43-92320T	18-2409	46-812966A7	18-3445	47-97108M	18-3069	50-812604A2	18-6275
43-96084A4	18-2200	46-812996A3	18-3445	50-12066A1	18-4915	50-818445-2	18-5620
43-96084A5	18-2410	46-812996A9	18-3445	50-12066A9	18-4915	50-818445-3	18-5620
43-96084A7	18-2410	46-84277M	18-3148	50-12066Q9	18-4915	50-8184455	18-5620
44-17915	18-2260	46-84277T	18-3148	50-12121A2	18-6275	50-819271	18-6864
44-55857	18-2166	46-862914A13	18-3160-1	50-12177A2	18-5910	50-820193A1	18-6864
44-66060	18-2166	46-879194401	18-3506	50-12177A2	18-6275	50-822330A2	18-5913-1
44-660602	18-2166	46-96146A2	18-3416	50-12872	18-5903	50-822330A2	18-6275
44-660603	18-2166	46-96146A5	18-3414	50-17251A2	18-5908	50-822462	18-5621
44-824110	18-2166	46-96146A6	18-3416	50-17251A3	18-5908	50-822462T1	18-5621
44-850308	18-2254	46-96148	18-3116	50-17251A3	18-5911	50-825991A2	18-6940
44-94148	18-2239	46-96148A1	18-3116	50-22791A1	18-4915	50-830308T	18-6437
44-98418	18-2260	46-96148A5	18-3517	50-28985A2	18-4915	50-831001671	18-6954
45-42634	18-2180	46-96148A8	18-3316	50-38890A1	18-5601	50-831001672	18-6954
45-43031A1	18-1736	46-96148A8	18-3517	50-41583	18-6828	50-831002050	18-6954
45-440001	18-1737	46-96148T1	18-3116	50-44369	18-5606	50-831002051	18-6954
45-55796	18-2179	47-11590M	18-3066	50-44369A1	18-5602	50-831002052	18-6954
45-557961	18-2324	47-16154	18-3098	50-44369A1	18-5606	50-8329972	18-6282
45-816919	18-2261	47-161543	18-3098	50-44369A1	18-5642	50-8331535	18-6283
45-853647	18-2331	47-19453	18-8900	50-44414	18-5608	50-834749	18-6436
45-853648	18-2331	47-20813	18-3008	50-44414	18-5608	50-852570	18-6829
46-32437A1	18-3517	47-22748	18-3012	50-44415	18-5608	50-852570T	18-6829
46-32437A3	18-3316	47-25287	18-3008	50-44415	18-5608	50-853329T	18-6440
46-42040A1	18-3149-2	47-30221	18-3017	50-45093	18-4915	50-854636T	18-6438
46-42040A3	18-3149-2	47-39074	18-3039	50-47455	18-5908	50-857065	18-6829
46-42040A5	18-3149-2	47-420381	18-3062	50-55601	18-5601	50-859168	18-6829
46-42579A3	18-3419	47-420382	18-3062	50-55601A2	18-5601	50-859168T	18-6829
46-42579A4	18-3319	47-42038Q02	18-3062	50-56886	18-5903	50-859169T	18-6437
46-42579A4	18-3517	47-430261	18-3056	50-57465A1	18-5636	50-859170T	18-6438
46-43024A3	18-3572	47-430262	18-3056	50-57867	18-5636	50-859171T	18-6436
46-44292A3	18-3420	47-430264	18-3056	50-58788A3	18-5602	50-859377T	18-6435
46-44292A4	18-3517	47-43026Q06	18-3265	50-58788A3	18-5636	50-863007A1	18-6275
46-44292Q03	18-3420	47-43026T11	18-3214	50-60315	18-5606	50-864340A2	18-5913-1
46-44292T1	18-3420	47-43026T11	18-3265	50-64975	18-5636	50-864340A2	18-6275
46-48743A1	18-3116	47-43026T2	18-3056	50-65784A1	18-5908	50-86976	18-6825
46-48744A3	18-3448	47-43026T6	18-3214	50-66015	18-5642	50-884044T	18-6435
46-48745A1	18-3422	47-43026T8	18-3214	50-660151	18-5610	50-884045T	18-6438
46-48746A1	18-3118	47-56780	18-3052	50-660153	18-5610	50-888151T	18-6437
		47-59362	18-3087	50-66015T	18-5610	50-888160T	18-6438

O.E. #	SIERRA #	O.E. #	SIERRA #	O.E. #	SIERRA #	O.E. #	SIERRA #
MERCURY MARINE cont.		57-65607Q	18-15370	57-96834Q	18-15500	87-17009A2	MP41070-2
50-888161T	18-6435	57-65607T	18-15370	57-96834T	18-15500	87-17009A5	MP51090
50-892339T	18-6440	57-69143Q	18-15400	81-64851	18-5346	87-17009A5	MP51092
50-893890T	18-5621	57-69143T	18-15400	84-43376A12	18-8802-1	87-18211	18-5729
50-893891T	18-5602	57-74271	18-15345	84-43376A7	18-8800-1	87-19761	18-5737
50-893891T	18-5642	57-74271Q	18-15345	84-43376A8	18-8809-1	87-71831	18-5317
50-893892T	18-5610	57-74271T	18-15345	84-43376A9	18-8803-2	87-861780A2	18-5116-1
50-893894	18-6943	57-76269	18-15405	84-813706A26	18-5225	87-861780Q4	18-5116-1
50-897755T	18-6840	57-76269Q	18-15405	84-813706A56	18-28081	87-88107	MP41000
50-898265005	18-5605	57-77274	18-15345	84-813715A1	18-5227-1	87-88107A5	MP52000
50-8M0033984	18-5611	57-77274A1	18-15325	84-813715A1	18-5228-1	87-892150A02	18-5116-1
50-90983A1	18-5611	57-78200	18-15470	84-813715A8	18-28082	88-79023A91	18-8220
50-90983T1	18-5611	57-78200A1	18-15470	84-813720A10	18-8803-2	88-93582	18-15501
50-97499A2	18-5907	57-78200Q1	18-15470	84-813720A11	18-8810-1	89-15857	18-5815
50-97499R4	18-5907	57-8077554	18-15112	84-813720A12	18-8802-1	89-18080	18-5837
50-99417A2	18-5911	57-8077555	18-15113	84-813720A13	18-8811-1	89-61053	18-5815
50-99418A2	18-5910	57-8077550Q4	18-15112	84-813720A2	18-8804-1	89-65258	18-5815
50-99418A2	18-6275	57-816295Q	18-15490	84-813720A3	18-8804-1	89-68258A4	18-5815
50-99419A3	18-5908	57-816295T	18-15490	84-813720A3	18-8821-1	89-76416A1	18-5801
50-99419A3	18-5911	57-816544	18-15410	84-813720A4	18-8804-1	89-76545	18-5815
52-12777	18-2236	57-817113	18-15125	84-813720A4	18-8821-1	89-76545T	18-5815
52-34239	18-2236	57-828507Q4	18-18100	84-813720A5	18-8800-1	89-817109A2	18-5834
52-66063	18-2202	57-861049	18-15114	84-813720A6	18-8808-2	89-818864	18-5818
52-814756	18-2236	57-8610491	18-15102	84-813720A7	18-8801-1	89-818864T	18-5818
52-822539	18-2236	57-861049Q	18-15114	84-813720A8	18-8809-1	89-818997A1	18-5819
52-822539T	18-2236	57-861050	18-15103	84-813720A9	18-8803-2	89-818997A2	18-5819
52-824112	18-2202	57-861757	18-15115	84-816608A14	18-8833-1	89-818997T1	18-5819
52-850048T	18-1562	57-861757Q	18-15115	84-816608A68	18-8832-1	89-818999A2	18-5820
52-853594	18-2202	57-861758	18-15116	84-816608A71	18-8836-1	89-825096T	18-5821
52-853594T	18-2202	57-861758Q	18-15116	84-816608A81	18-8822-1	89-825842A1	18-5820
52-859340T	18-1565	57-861759	18-15117	84-816608A83	18-8834-1	89-850188T1	18-5820
53-29641	18-4295	57-862086	18-15101	84-816608K68	18-8832-1	89-853654A1	18-5815
53-805272	18-4289	57-8620861	18-15101	84-816608Q14	18-8833-1	89-91975	18-5816
53-815949	18-2345	57-862086A1	18-15101	84-816608Q61	18-8804-1	89-96054	18-5816
53-850048	18-1562	57-862087A1	18-15100	84-816608Q68	18-8832-1	89-96054T	18-5816
54-31765	18-710-72-2	57-862088	18-15105	84-816608Q71	18-8836-1	89-96158	18-5817
54-32533	18-710-48-2	57-862088A1	18-15105	84-816608Q78	18-8824-1	89-96158T	18-5817
54-38863	18-7321	57-862089	18-15104	84-816608Q80	18-8830-1	89-99253	18-5838
54-41582-7	18-8020	57-862089A1	18-15104	84-816608Q81	18-8822-1	91-12037	18-9806E
54-815504348	18-710-48-2	57-8623523	18-15119	84-816608Q82	18-8835-1	91-12427	18-9807
54-866507	18-7321	57-862807	18-15100	84-816608Q83	18-8834-1	91-12427T	18-9807
54-8M0090424	18-7321	57-8638761	18-15119	84-816761A12	18-8802-1	91-14311A04	18-9874
56-18541A75	18-2464	57-86387610	18-15122	84-816761A17	18-8821-1	91-14311A1	18-9874
56-864641A24	18-2464	57-8638763	18-15100	84-816761A4	18-8804-1	91-14311A2	18-9874
57-13457	18-15290	57-8638764	18-15101	84-816761A4	18-8821-1	91-15755	18-9808
57-13457Q	18-15290	57-8638765	18-15121	84-816761A7	18-8800-1	91-15755T	18-9808
57-13457T	18-15290	57-8638766	18-15102	84-816761A8	18-8809-1	91-17256	18-9803
57-13458	18-15550	57-8638767	18-15103	84-816761A9	18-8803-2	91-17257	18-9809
57-13458Q	18-15550	57-8638768	18-15104	84-816761K14	18-8833-1	91-17262A1	18-9810
57-13458T	18-15550	57-8638769	18-15105	84-816761Q10	18-8803-2	91-17275A1	18-9812
57-32850	18-15400	57-864639	18-15123	84-816761Q12	18-8802-1	91-23033	18-9817
57-32850	18-15410	57-865423005	18-15121	84-816761Q13	18-8811-1	91-23033T	18-9817
57-33170	18-15520	57-865615001	18-15119	84-816761Q16	18-8810-1	91-24150	18-9817
57-33170Q	18-15520	57-865615003	18-15100	84-816761Q17	18-8821-1	91-29310	18-9814
57-36356	18-15415	57-865615004	18-15101	84-816761Q3	18-8804-1	91-30366T1	18-9816
57-37619T	18-15520	57-865615005	18-15121	84-816761Q3	18-8821-1	91-30500	18-9785
57-45856	18-15440	57-865615006	18-15102	84-816761Q4	18-8804-1	91-31107	18-9817
57-48120	18-15460	57-865615007	18-15103	84-816761Q4	18-8821-1	91-31107T	18-9817
57-48120A1	18-15460	57-865615008	18-15104	84-816761Q5	18-8800-1	91-31109	18-9808
57-48120Q1	18-15460	57-865615009	18-15105	84-816761Q6	18-8808-2	91-31229	18-9819
57-48122	18-15480	57-865615010	18-15122	84-816761Q7	18-8801-1	91-31229A7	18-9820-1
57-48122Q	18-15480	57-865615Q01	18-15119	84-816761Q8	18-8809-1	91-32325	18-9821
57-49043	18-15410	57-865615Q03	18-15100	84-816761Q9	18-8803-2	91-32325T	18-9821
57-49043A1	18-15410	57-865615Q04	18-15101	84-821945A56	18-28080	91-32336	18-9822
57-49211	18-15430	57-865615Q05	18-15121	84-847701A7	18-8837-1	91-33489	18-9823
57-49211	18-15435	57-865615Q06	18-15102	84-847701Q7	18-8837-1	91-33491	18-9824
57-49213A1	18-15440	57-865615Q07	18-15103	84-863656A1	18-8828-1	91-33492	18-9825
57-49756	18-15300	57-865615Q08	18-15104	84-863656A2	18-8829-1	91-33492T	18-9825
57-52692	18-15390	57-865615Q09	18-15105	84-881262A2	18-6500	91-33493	18-9826
57-53215	18-15290	57-880566014	18-15128	84-881698	18-8838-1	91-33493T	18-9826
57-53215T	18-15290	57-881754	18-15124	84-881908T	18-28083	91-34379T	18-9827
57-64032	18-15410	57-892318	18-18000	84-881908T	18-28084	91-36235	18-9803
57-64032A1	18-15410	57-895120	18-15149	84-881908T	18-28085	91-36379	18-9828
57-64032Q1	18-15410	57-895120002	18-15150	84-881908T	18-28086	91-36569	18-9829
57-64416	18-15430	57-91035	18-15495	84-90816A26	18-5225	91-36569T	18-9829
57-64416	18-15435	57-91035A1	18-15495	84-93212A1	18-5225	91-36571	18-9830
57-65607	18-15370	57-91035Q1	18-15495	84-93475A26	18-5225	91-36571T	18-9830
		57-96834	18-15550	84-99215A26	18-5225	91-36577	18-9831

O.E. #	SIERRA #	O.E. #	SIERRA #	O.E. #	SIERRA #	O.E. #	SIERRA #
MERCURY MARINE cont.		91-99750A1	18-9801	92-8M0078627	18-9400CAT-2P	391-7057T	18-5404-1
91-36577T	18-9831	91-99750A1	18-9801	92-8M0078629	18-9440CAT-2	391-898253001	18-5338
91-37263	18-9808	92-34227	1525607	92-8M0078629	18-9440CAT-2P	391-898253004	18-5314
91-37292	18-9832	92-342271	1525607	97-31640B4	18-6011	391-898253029	18-5404-1
91-37311	18-9833	92-34227Q02	1525607	97-31640Q4	18-6011	392-2529	18-6256
91-37312	18-9834	92-41669-1	37534	97-34672C	18-6013	392-2940	18-6254
91-37323	18-9835	92-59327-1	37509	97-762145	18-6016	392-6318	18-5369
91-37324	18-9815	92-78383A12	18-9013	97-76214Q5	18-6016	392-6318T	18-5369
91-37350	18-9836	92-78383A12	18-9024	97-806188A1	18-6117A	392-6324	18-5347
91-37384	18-4442	92-78383A12	18-9065	97-806188A1	18-6117M	392-6325	18-5303
91-38277A1	18-4444	92-78383A12	18-9080	97-806188A1	18-6117Z	392-6326	18-5407
91-38628T	18-9837	92-802833Q1	18-9420-2P	97-806188Q01	18-6117A	392-6326T	18-5407
91-38756	18-9838	92-802833Q1	18-9420-2	97-806188Q01	18-6117M	392-6329	18-5399
91-38918T	18-9839	92-802835Q1	18-9420-3P	97-806188Q01	18-6117Z	392-7803A4	18-5438
91-38919	18-9840	92-802835Q1	18-9420-30	97-806189	18-6067	392-805570A2	18-5438
91-42840T	18-9841	92-802835Q1	18-9420-30P	97-806189	18-6067A	392-806529A1	18-5433
91-43506T	18-9842	92-802835Q1	18-9420-3	97-806189Q1	18-6067	392-8261A1	18-6768
91-43559	18-9843	92-802836A1	18-9420-7P	97-806189Q1	18-6067A	392-8261A1	18-6799
91-43579	18-9844	92-802836A1	18-9420-7	97-806190	18-6089	392-8263	18-6768
91-43591T	18-9845	92-802837Q1	18-9400-2	97-806190B4	18-6089	392-8263	18-6799
91-44110	18-9846	92-802841A1	18-9400-7	97-806190Q1	18-6089	392-881732	18-7648
91-44307A1	18-9874	92-802844Q02	18-9600-0	97-821629Q1	18-6080	392-898253002	18-5347
91-45497A1	18-9847	92-802859A1	18-9240-0	97-821629Q1	18-6099	392-898253005	18-5303
91-47448A1	18-9896	92-802863A1	18-9240-1	97-821630Q1	18-6094	392-8989	18-6255
91-48347	18-4442	92-802881A1	1525607	97-826134Q	18-6068	392-9086	18-5353
91-52393	18-9848	92-802882A1	37534	97-888755Q03	18-6158M	392-9086T	18-5353
91-52394	18-9849	92-809819	37478	97-888756Q03	18-6158A	392-9089	18-5403
91-53459	18-9850	92-809820	37479	97-888758Q03	18-6159A	392-9089Q	18-5403
91-55916	18-9851	92-809824	37509	97-888759Q03	18-6159M	392-9089T	18-5403
91-55918	18-9852	92-817529A12	18-9013	97-888760Q03	18-6160M	392-9766	18-5352
91-56048001	18-9853	92-817529A12	18-9024	97-888761Q03	18-6160A	392-9766Q1	18-5352
91-56048T	18-9853	92-817529A12	18-9065	332-4911A5	18-5787	392-9766T	18-5352
91-56775T	18-9854	92-817529A12	18-9080	332-4911A8	18-5787	392-9767	18-5403
91-57797A1	18-4442	92-823506 1	37534	332-5524A1	18-5775	393-3230	18-5389
91-57797A2	18-4442	92-857389A1	18-9400-4	332-5772A1	18-5881	393-4988	18-5389
91-57797A3	18-4442	92-858007Q01	18-9600-5	332-5772A2	18-5881	393-4988T	18-5389
91-60523	18-9855	92-858007Q01	18-9600-5P	332-5772A3	18-5881	393-4988T2	18-5389
91-60526T	18-9856	92-858008Q01	18-9650-5	332-5772A5	18-5881	393-9459	18-5385
91-61067A3	18-9857	92-858008Q01	18-9650-5P	332-7778A1	18-5775	393-9459Q1	18-5385
91-61069T	18-9858	92-858037K01	18-9530-3	332-7778A12	18-5775	393-9459T	18-5385
91-61077	18-9868	92-858039K01	18-9530-7	332-7778A3	18-5775	394-1100A2	18-5148
91-63616	18-9859	92-858042K01	18-9553-3	332-7778A6	18-5775	394-1100A3	18-5148
91-63638T	18-9860	92-858042Q01	18-9553-3	332-7778A7	18-5775	394-1130	18-5169
91-74057Q6	18-9782	92-858057K01	18-9440-7	332-7778A9	18-5775	394-1130A1	18-5169
91-74057Q6	18-9783	92-858058Q01	18-9600-2	336-3948A2	18-5139	394-352A1	18-5148
91-75132	18-9896	92-858058Q01	18-9600-2P	336-3948A3	18-5139	397-359	18-5169
91-78310	18-9861	92-858061Q01	18-9600-6	336-3996A7	18-5855	397-741	18-5169
91-813653	18-9873	92-858062Q01	18-9600-7	336-4318A2	18-5139	398-174	18-5153
91-817570T	18-9869	92-858062Q01	18-9600-7P	336-4318A3	18-5139	398-2202	18-5140
91-818162	18-9870	92-858064Q01	18-9650-2	336-4318A4	18-5139	398-5255	18-5856
91-818169T	18-9871	92-858064Q01	18-9650-2P	339-6222A8	18-5788	398-5454A17	18-5854
91-821571A1	18-9872	92-858067Q01	18-9650-6	339-7370A13	18-5186	398-5454A21	18-5874
91-821887A1	18-4459	92-858067Q01	18-9650-6P	339-7452A1	18-5776	398-5454A22	18-5859
91-850730Q01	18-9781	92-858068Q01	18-9650-7	339-7452A11	18-5778	398-5454A25	18-5874
91-859046Q4	18-4459	92-858068Q01	18-9650-7P	339-7452A14	18-5778	398-5454A32	18-5871
91-859046T4	18-4459	92-858084K01	18-9552-3	339-7452A15	18-5777	398-5454A35	18-5860
91-87119	18-9862	92-883722K01	18-9440-8	339-7452A19	18-5777	398-5454A63	18-5874
91-878232	18-9896	92-883723K01	18-9440-3	339-7452A2	18-5776	398-5454A7	18-5857
91-879172T28	18-79816	92-883724K01	18-9440-2	339-7452A21	18-5778	398-5704A7	18-5865
91-883704Q03	18-9794	92-883724K01	18-9440-2P	339-7452A3	18-5776	398-5919A2	18-5874
91-895343A02	18-9897	92-883725K01	18-9440-4	339-7452A7	18-5777	398-5919A3	18-5859
91-895343T01	18-9897	92-883725K01	18-9440-4P	339-7452A8	18-5778	398-5919A4	18-5866
91-895343T02	18-9897	92-8M0062765	18-8606	339-7452A9	18-5777	398-5919A6	18-5874
91-896661	18-79814	92-8M0071837	18-9200-2	339-832757A4	18-5186	398-5919A7	18-5859
91-89865	18-9863	92-8M0071837	18-9200-4	339-850227	18-5187	398-5919A8	18-5874
91-89897	18-9866	92-8M0071838	18-9200-0	339-856991A1	18-5187	398-693	18-5206
91-8M0067546	18-4442	92-8M0071841	18-9200-1	339-859738T1	18-23205	398-713	18-5207
91-8M0072133	18-9781	92-8M0078618	18-9420CAT-7	339-880615T01	18-5154	398-818535A15	18-5874
91-8M0101435	18-9650-2QP	92-8M0078618	18-9420CAT-7P	391-5075	18-5376	398-832075-A21	18-5870
91-90244A1	18-9875	92-8M0078621	18-9400CAT-7	391-5075Q1	18-5376	398-832075A14	18-5874
91-90455	18-9896	92-8M0078621	18-9400CAT-7P	391-5076	18-0422	398-832075A20	18-5874
91-904551	18-9896	92-8M0078624	18-9440CAT-7	391-5081	18-7143	398-832075A4	18-5870
91-90455T	18-9896	92-8M0078624	18-9440CAT-7P	391-5088	18-5404-1	398-832075A6	18-5873
91-90455T1	18-9896	92-8M0078625	18-9420CAT-2	391-5090	18-5314	398-9610A19	18-5876
91-90774	18-9865	92-8M0078625	18-9420CAT-2P	391-5092	18-5338	398-9873A4	18-5867
91-95830	18-4444	92-8M0078626	18-9420CAT-3	391-5092	18-5338	700-858294T1	18-4639
91-95830A1	18-4444	92-8M0078626	18-9420CAT-3P	391-5093	18-5338	700-858295T1	18-4640
91-99379	18-9802	92-8M0078627	18-9400CAT-2	391-7057	18-5404-1	700-878571A2	18-4641

O.E. #	SIERRA #	O.E. #	SIERRA #	O.E. #	SIERRA #	O.E. #	SIERRA #
MERCURY MARINE cont.		778-9015A2	18-4109	1395-8318	18-7061	1399-1754	18-7832
700-878572A2	18-4642	778-9441A3	18-4109	1395-83181	18-7061	1399-2015	18-7006-1
700-878573A2	18-4643	778-9441A5	18-4134	1395-8506	18-7354	1399-3523	18-7006-1
700-878574A2	18-4644	780-9229A10	18-4621	1395-8673	18-7208	1399-3938	18-7832
733-2278	18-4180	780-9229A11	18-4622	1395-879194024	18-7006-1	1399-5135	18-7007
733-3818	18-4160	780-9229A7	18-4620	1395-8983	18-7208	1399-5137	18-7815
733-38181	18-4160	783-9613A2	18-4017	1395-9022	18-7295	1399-5198	18-7007
733-3819	18-4161	783-9613A3	18-4018	1395-9024	18-7215	1399-99	18-2575
733-3819	18-4191	783-9613T2	18-4017	1395-9179	18-7212	1547-3917A13	18-2450
733-38191	18-4191	783-9613T3	18-4018	1395-9258	18-7057	1547-3917A16	18-2451
733-4028	18-4161	785-9737A10	18-4637	1395-9258 1	18-7057	1547-3917A21	18-2450
733-4028	18-4191	785-9737T9	18-4635	1395-9267	18-36956	1547-3917A30	18-2451
733-66217	18-4180	785-97386	18-7961	1395-9293	18-7209	1547-3917A32	18-2450
733-803850T	18-4161	785-9738T10	18-4638	1395-9377	18-7212	1547-3917A37	18-2450
733-803850T	18-4191	785-9738T9	18-4636	1395-9594	18-7200	1547-3917A38	18-2451
735-6370	18-4173	936-810840	18-4489	1395-95951	18-7062	1547-3917A4	18-2451
735-6370	18-4173	936-986767	18-4489	1395-9599	18-7750-1	1547-3917A8	18-2451
735-6371	18-4164	938-803860T	18-4486	1395-9645	18-7212	1547-5523A11	18-2451
735-6538	18-4181	938-827178	18-4491	1395-9650	18-7226	1547-5523A12	18-2450
735-808661	18-4173	938-883297 1	18-4486	1395-9725	18-7212	1547-5523A2	18-2450
735-808674	18-4173	938-883490	18-4485	1395-9761	18-7212	1547-5523A49	18-2453
735-808674A1	18-4173	938-883490R1	18-4485	1395-97611	18-7212	1547-5523A67	18-2452
735-850097	18-4173	938-883490R50	18-4485	1395-9803	18-7212	1547-5523A67	18-2453
735-850098	18-4164	938-884741R	18-4485	1396-4148	18-7227	1547-5523A68	18-2450
735-9431	18-4164	938-884741R50	18-4485	1396-4656	18-7081	1547-5523A8	18-2451
735-9686	18-4173	1337-2103	18-7078	1396-5222	18-7096	1547-5523A9	18-2450
735-9687	18-4164	1337-2604	18-7078	1396-5238	18-7096	1547-815930A13	18-2419
735-9703	18-4173	13447A1	18-5313-1	1397-2060	18-7200	1547-815930A16	18-2416
735-9704	18-4164	1346-2770	18-7080	1397-2067	18-7746	1547-815930A3	18-2419
735-9715	18-4178	1347-804623A1	18-7605-1	1397-2072	18-7070	1547-815930A6	18-2416
735-97151	18-4178	1347-804623R02	18-7604-1	1397-2133	18-7078	1547-8265A15	18-2450
735-9715T1	18-4178	1347-804623R02	18-7605-1	1397-2150	18-7855	1547-8265A16	18-2451
736-2343	18-4180	1347-804623R1	18-7604-1	1397-2605	18-7078	1547-8265A17	18-2452
737-6523	18-4189	1347-804624 R02	18-7615-1	1397-2631	18-7746	1547-8265A17	18-2453
737-879194035	18-4189	1347-804624 R1	18-7618-1	1397-2634	18-7746	1547-861063A12	18-2416
743-3193A2	18-4620	1347-804624R02	18-7618-1	1397-2637	18-7070	1547-861063A4	18-2411
743-3193A4	18-4620	1347-804624R1	18-7615-1	1397-2637	18-7746	1547-861063A6	18-2419
743-3366A1	18-4621	1347-804625R02	18-7617-1	1397-3306	18-7072	1547-9412A20	18-2450
743-3366A2	18-4621	1347-804625R1	18-7617-1	1397-3327	18-7201	1547-9412A21	18-2451
743-5172A6	18-4620	1347-804626 R02	18-7616-1	1397-3458	18-7071	1547-9412A22	18-2452
743-7716A2	18-4622	1347-816373A4	18-7615-1	1397-3459	18-7746	1547-9412A23	18-2453
759-592010	18-4109	1347-818619	18-7609-1	1397-3462	18-7078	1547-9412A30	18-2450
759-592012	18-4134	1347-818619 1	18-7609-1	1397-3464	18-7070	1547-9412A35	18-2450
759-661010	18-4109	1347-818619 1R02	18-7609-1	1397-3464	18-7746	1547-9412A36	18-2452
759-661012	18-4134	1347-818620	18-7608-1	1397-4329	18-7072	1623-4110A13	18-2443
759-80661A3	18-4109	1347-818620 1	18-7608-1	1397-5635	18-7072	1623-4110A4	18-2443
759-80661A7	18-4109	1347-818620R02	18-7608-1	1397-5830	18-7075	1623-4110A6	18-2443
759-80661A8	18-4134	1347-818621	18-7610-1	1397-5831	18-7075	1623-5356A18	18-2443
759-806661A5	18-4134	1347-818621 1	18-7610-1	1397-5837	18-7202	1623-5356A19	18-2443
759-831210	18-4109	1347-818621 1R02	18-7610-1	1397-6367	18-7076	1623-5356A20	18-2443
759-831212	18-4134	1347-818622	18-7603-1	1397-6367A1	18-7076	1623-5356A3	18-2443
759-8312A2	18-4109	1347-818622 1	18-7603-1	1397-6638	18-7072	1623-5356A4	18-2402
759-8312A6	18-4134	1347-818622R02	18-7603-1	1397-7099	18-7075	1623-815822A3	18-2400
759-9015A4	18-4134	1347-8288A1	18-7616-1	1397-7539	18-7095	1623-815822A32	18-2400
761-7131M	18-4135	1347-8289A1	18-7618-1	1397-7540	18-7095	1623-815822A36	18-2415
761-7133M	18-4135	1347-8460A3	18-7619-1	1397-7542	18-7070	1623-815822A5	18-2400
761-7134M	18-4135	1347-9142A2	18-7619-1	1397-7542	18-7746	1623-815822A53	18-2400
761-7196M	18-4138	1347-9661A3	18-7605-1	1397-7543	18-7070	1623-8951A14	18-2443
761-7197M	18-4138	1347-9863A3	18-7617-1	1397-7543	18-7746	1623-8951A15	18-2401
761-7198M	18-4138	1356-4066	18-7096	1397-7544	18-7095	1623-8951A19	18-2443
761-7982M	18-4135	1356-4092	18-7096	1397-7547	18-7746	1623-8951A2	18-2443
761-7982T	18-4135	1356-5155	18-7096	1397-8535	18-7095	1623-8951A23	18-2443
761-8484M	18-4138	1356-5169	18-7096	1397-8545	18-7869	1623-8951A27	18-2401
765-7443A11	18-4013	1376-5659A1	18-7603-1	1397-8546	18-7201	1623-8951A37	18-2401
765-7443A12	18-4560	1395-4808	18-7006-1	1397-8582	18-7666	1623-8951A43	18-2443
765-7443A2	18-4560	1395-6200	18-7004	1397-8760	18-7075	1623-8951A5	18-2401
765-7446A11	18-4014	1395-6452	18-7005	1397-8767	18-7869	1647-9148T93	18-4832
766-8667A36	18-4565	1395-7824	18-7233	1397-8872	18-7070	1667-9011G59	18-4830
766-8667A43	18-4565	1395-811222	18-7750-1	1397-8872	18-7746	1667-9011R6	18-4850
774-9137A10	18-4515	1395-8112231	18-7211-1	1397-8873	18-7746	2704-812896A2	18-4626
774-9137A14	18-4535	1395-811357	18-7212	1397-8952	18-7077	2704-821896A3	18-4627
776-8898A2	18-4535	1395-811691 2	18-7355	1397-8959	18-7201	2704-821896A4	18-4628
776-9096A1	18-4156	1395-811691 3	18-7356	1397-9723	18-7095	2704-821896A6	18-4626
777-815965A4	18-4623	1395-823635	18-7750-1	1398-3089	18-7080	2704-826191A4	18-4626
777-815965A5	18-4624	1395-8236351	18-7750-1	1399-1136	18-7832	2704-826191A6	18-4626
777-815965A6	18-4625	1395-8236352	18-7750-1	1399-1138	18-7057	2704-826191T4	18-4626
777-815965T4	18-4623	1395-8236353	18-7750-1	1399-1473	18-7057	3302-804844	18-7098-1
		1395-8236354	18-7750-1	1399-1717	18-7006-1	3302-804844001	18-7098-1

O.E. #	SIERRA #	O.E. #	SIERRA #	O.E. #	SIERRA #	O.E. #	SIERRA #
MERCURY MARINE cont.		33149	18-2193	52444	18-7848-1	73813	18-1990
3302-804844002	18-7098-1	33261	18-5838	52731	18-7824-2	73873	18-8227
3302-804845	18-7097	33266	18-5315-1	52731	18-7876-1	74639	18-2753-2
3302-9031	18-7202	33270	18-5717	52999	18-4009	75384	18-5697
3302-9033	18-7859	33316	18-5838	53114	18-2759	75639	18-0615
3302-9437	18-7097	33662	18-5345	54111	18-7824-2	75661	18-5674
3304-9354A2	18-7604-1	33667	18-5385	54111	18-7876-1	75692	18-3553
3310-806969 R01	18-7613-1	33700	18-5310	54534	18-3577-2	75832	18-2104
3310-806969A1	18-7613-1	33706	18-5344	54552	18-7267	75832	18-2174
3310-807312A1	18-7611-2	33707	18-5300	54705	18-3107	76214	18-6016
3310-807312R02	18-7611-2	33708	18-5384	54793	18-3599-2	76214	18-60161
3310-864943A01	18-7639	33765	18-5386	54870	18-1990	76214	18-6016A
3310-866142A03	18-79994N	33981	18-2162	54981	18-5802	76214	18-6244
3310-866142A04	18-79994N	33981	18-2162E	55481	18-7853-1	76270	18-3552
3310-866143A03	18-79995N	34127	18-6012	55989	18-60151-9	76865	18-2130
728374-92605	18-55503	34235	18-5311	56045	18-5956	77123	18-1705
815279-1	18-5741	34282	18-1402	56045	18-5957	77326	18-2144
815279-3	18-5743	34623	18-5899	56153	18-1401	77443	18-2148
815279-5	18-5743	34625	18-5898	56879	18-3584-1	77481	18-2150
819762A4-A7	18-6777	35329	18-4492	57380	18-5650	77594	18-7278
81977A8-A9	18-6777	35341	18-3599-2	57882	18-7232	78016	18-5420
85785-2	18-7229	35583	18-1402	58033	18-5318	78249	18-2143
99186-1	18-6273-1	35884	18-3551	58034	18-5346	78458	18-2760
F694961-1	18-2346	35915	18-3759	58086	18-3584	78477	18-5956
F74305-1	18-7176	35957	18-3593	58217	18-5418	78477	18-5957
6325	18-5345	35983	18-4296	58231	18-5315-1	78485	18-7274
12415	18-5896	35992	18-3752	58749	18-2104	78687	18-2144
12449	18-5957	36147	18-2101	58749	18-2174	78820	18-7275
12449	18-5965	36223	18-2752	59078	18-3550	79448	18-3751
12449	18-5966	36312	18-2104	59137	18-3551	85552	18-2742
12708	18-1240	36312	18-2174	59755	18-5956	86177	18-5658
12784	18-6400	36525	18-5897	59755	18-5957	86234	18-7278
13037	18-5804	37369	18-3593	59972	18-3577-2	86246	18-7274
14244	18-0616	37721	18-0539	60207	18-4008	86247	18-7275
14259	18-0612	37951	18-3599-2	60252	18-4009	86459	18-9099
14586	18-3549	37967	18-2196	60565	18-7875	86814	18-1710
14698	18-2373	37973	18-2150	60658	18-3599-2	87581	18-5315-1
14760	18-0615	38463	18-7878-1	60687	18-5838	88035	18-2372
14957	18-7824-2	38547	18-5433	60930	18-2727	88726	18-8305
14957	18-7876-1	39383	18-2128	61073	18-2196	89876	18-7853-1
16253	18-7381	39384	18-2125	61851	18-1906	89902	18-5838
16755	18-2516	39920	18-1973	62092	18-7267	90794	18-5956
16755	18-2615	41431	18-2104	62092	18-7267	90794	18-5957
17340	18-1400	41431	18-2174	62104	18-2322	90806	18-5899
17437	18-3599-2	41639	18-7230	62424	18-5315-1	90880	18-1905
17646	18-6771	41815	18-7879-1	62981	18-3553	92497	18-5957
17649	18-6772	42785	18-5740	63196	18-7275	92497	18-5965
17670	18-3577-2	42838	18-8305	64850	18-5317	92497	18-5966
18525	18-6771	43023	18-1838	65028	18-2150	92802	18-2733
18717	18-8309	43433	18-2149	65057	18-5802	93320	18-1908
19273	18-7249	43436	18-3754	65142	18-3593	93322	18-1985
19643	18-4261	43557	18-5395	65547	18-1705	93423	18-3199
20121	18-5224	43585	18-1730	65864	18-5420	93424	18-3198
20175	18-2146	43713	18-2724	66062	18-2130	93476	18-0613
20250	18-2015	45523	18-2148	66066	18-2150	93477	18-0615
20311	18-7459	46020	18-2125	66067	18-2286	94318	18-5817
22879	18-2149	46472	18-1402	66071	18-3752	94576	18-3350
25661	18-5836	46692	18-7878-1	66850	18-3553	94916	18-3351
29196	18-8070	46744	18-1402	67209	18-2144	97257	18-5897
29196	18-8084	46860	18-7275	67210	18-2143	97258	18-5898
29880	18-2149	46895	18-3139	67859	18-3577-2	97399	18-7288-1
30605	18-3117	47441	18-1977-1	68100	18-2342	97401	18-7283
31640	18-6011	47585	18-7278	68575	18-5656	99186	18-6273-1
31640	18-6011A	47587	18-1910	69668	18-8305	110990	18-0980
31640	18-6241	47588	18-1910	69729	18-5956	195141	18-5315-1
31659	18-2753-2	47594	18-3557	69729	18-5957	256611	18-5836
32170	18-6013	47638	18-1995	70125	18-7665	316403	18-6011
32435	18-3117	47886	18-5808	70977	18-3113	316404	18-6011
32489	18-3219	48045	18-1990	70981	18-2762	324351	18-3117
32716	18-7824-2	48752	18-3114	71327	18-7278	393831	18-2128
32716	18-7876-1	48753	18-3115	71464	18-7667	428381	18-8305
32717	18-7824-2	49117	18-1402	71646	18-7274	460201	18-2125
32717	18-7876-1	49139	18-3577-2	71683	18-3584-1	573001	18-5603
32722	18-7256	52022	18-7824-2	72625	18-7667	621041	18-2322
32728	18-3551	52022	18-7876-1	72638	18-1402	681001	18-2342
32734	18-2750	52226	18-3599-2	72777	18-3351	684311	18-7083
32768	18-3107	52352	18-5315-1	72778	18-3350	758321	18-2104
		52353	18-3593	73345	18-4233	758321	18-2174

O.E. #	SIERRA #	O.E. #	SIERRA #	O.E. #	SIERRA #	O.E. #	SIERRA #
MERCURY MARINE cont.		850399	18-3599-2	392889925	18-7493	14336A6	18-6752
762142	18-6016	850454	18-3577-2	802630001	18-7663	14336A8	18-6746
774811	18-2150	850458	18-0614	811637001	18-5107-1	14336A8	18-6769-1
802206	18-7116	850484	18-5362	811637002	18-5107-1	14336A9	18-6752
802231	18-7121	850485	18-5408	833072002	18-3537	14336A9	18-6753
802276	18-2013	850487	18-5107-1	833072003	18-3536	14505A2	18-2172
802276	18-2026	853292	18-5852	833072004	18-3537	14586A3	18-43052
802464	18-5107-1	854445	18-7668	850399002	18-3599-2	14698T	18-2373
802630	18-7663	858763	18-7083	850454002	18-3577-2	14698T10	18-2373
802632	18-33104	859168	18-6829	855676002	18-43175	15103A3	18-1137
803148	18-7757	861249	18-7550	864297001	18-7556	16061T	18-5792
803149	18-7697	861260	18-7692	879150150	18-7682	16457A4	18-5395
803470	18-7878-1	861425	18-7551	879194024	18-7006-1	16610M	18-8070
804184	18-7382	861578	18-8297	879194241	18-7964-1	16755A1	18-2516
804412	18-5107-1	862132	18-1711	881693002	18-7698	16755A1	18-2615
804418	18-5354	862209	18-1710	885599004	18-3535	16755Q1	18-2516
804424	18-5408	862998	18-7701	892615001	18-7646	16755Q1	18-2615
804540	18-3638	864493	18-43015	892615002	18-7646	16755T1	18-2615
805100	18-3784	878187	18-7554	898253003	18-5345	16792A33	18-7508
805629	18-5021	878341	18-3599-2	898253005	18-5345	16792A39	18-7508
806105	18-6079	878342	18-3577-2	898253007	18-5318	17177A1	18-5313-1
806105	18-6093	879036	18-2830-1	898253008	18-5418	17340T	18-1400
806105	18-6093A	879078	18-9099	898253009	18-5402	17649T	18-6772
806189	18-6114	879366	18-1194	898253010	18-5405	17693A2	18-7633
806190	18-6092	880817	18-3593	898253011	18-5406	18309A2	18-2412-1
806190	18-6092A	881540	18-7979	898253012	18-5408	18311A17	18-2412-1
806490	18-5897	881731	18-7660	898253013	18-5245	18311A2	18-2412-1
807057	18-5851	882571	18-6948	11497M	18-7833	18312A3	18-2382
808483	18-5354	883514	18-3573	11502M	18-7765	18495A12	18-5790
808484	18-5405	883885	18-3584-1	12076A1	18-1975-1	18495A19	18-5790
809064	18-7748	883925	18-3573	12076A2	18-1972	18495A26	18-5790
809065	18-7749	884727	18-3593	12076A2	18-1975-1	18525A1	18-6771
809066	18-7664	884790	18-5245	12449A1	18-5957	18643A5	18-2323
809462	18-5811	884792	18-5244	12449A1	18-5965	18654A1	18-2750
809463	18-5811	885176	18-7688	12449A1	18-5966	19052A3	18-5791
809569	18-7380	888731	18-5243	12449A1	18-5966	19052A5	18-5791
809910	18-0612	892615	18-7646	12632A3	18-2195	19052A8	18-5791
811091	18-5897	892681	18-33211	12632A4	18-2175	19217A1	18-6777
811536	18-36906	893409	18-3607	12632A6	18-2321	19217A5	18-6777
811549	18-0614	895338	18-3556	12632A7	18-2195	19291A3	18-2370
811573	18-3577-2	934231	18-3199	12644A1	18-4457	19297A3	18-2145
811618	18-6751	934233	18-3199	12644Q01	18-4457	19405A4	18-5432
811628	18-6774	934241	18-3198	12784A10	18-6401	19543A10	18-2157
811635	18-5361	934243	18-3198	12784A4	18-6401	19543A10	18-2159
811636	18-5406	973513	18-2707	12784T	18-6400	19543A10	18-2190
811637	18-5107-1	1100990	18-0980	12886A6	18-1800	19543A10	18-2190E
811639	18-5108	4602002	18-2125	13191A1	18-4221	19543A2	18-2157
811841	18-3599-2	8052732	18-3649	13310T1	18-5674	19543A2	18-2159
814472	18-6275	8055361	18-2097	13330A3	18-8005EP-1	19543A2	18-2190
814755	18-3593	8072521	18-3551	13330A3	18-8005S	19543A2	18-2190E
815425	18-5899	8072522	18-3649	13330Q	18-8005S	19543A2	18-2190E
815471	18-2145E	8072531	18-3551	13524A4	18-5432	19543A4	18-2157
816597	18-3151	8094621	18-5811	13524A5	18-5431	19543A4	18-2159
816607	18-1728	8094631	18-5811	13524A6	18-5432	19543A4	18-2190
816685	18-3749	8107492	18-7213	13524Q06	18-5432	19543A8	18-2157
816770	18-5707	8107493	18-7214	13524T1	18-5431	19543A8	18-2159
816877	18-7083	8168111	18-3752	13753A2	18-5396	19543A8	18-2190
817276	18-3122	8168112	18-3752	14034A3	18-2420	19543A8	18-2190E
817377	18-5475	8168771	18-7083	14034A5	18-2420	19543T1	18-2603
817378	18-5443	8168772	18-7083	14034F1	18-2420	19543T1	18-2603E
821509	18-5852	8168773	18-7083	14034T	18-2420	19543T2	18-2603
821629	18-6080A	8172761	18-3122	14034T10	18-2420	19543T2	18-2603E
821630	18-6094A	8172763	18-3122	14035A3	18-2421	19755A08	18-2196
821630	18-6240	8213542	18-4577	14035A5	18-2421	19755A2	18-2286
822777	18-6014	8227731	18-0202-9	14035F1	18-2421	19755A4	18-2196
823033	18-5182	8227772	18-6014	14035T	18-2421	22831A1	18-8069
823034	18-5793	8235471	18-1839	14035T10	18-2421	22831A3	18-8069
823728	18-7749	8503991	18-3599-2	14244T	18-0616	22831A4	18-8069
824519	18-2346	8504541	18-3577-2	14307T01	18-7328	22831B3	18-8069
826134	18-6068	8504541	18-3577-2	14336A15	18-6752	22831Q3	18-8069
828151	18-5849	8504851	18-5408	14336A17	18-6752	23014A1	18-7804
828708	18-6773	8507521	18-2162	14336A20	18-6274	25661T1	18-5836
834832	18-6454	8507521	18-2162E	14336A20	18-6746	30185A1	18-8070
835076	18-7749	8507522	18-2162	14336A20	18-6746	30185A1	18-8084
846070	18-5817	8507522	18-2162E	14336A22	18-6752	30185A3	18-8070
849899	18-7683	16066004	18-25400	14336A25	18-6746	30185A3	18-8084
849934	18-7682	46020002	18-2125	14336A28	18-6752	30185B3	18-8070
		88245191	18-2346	14336A31	18-6746	30185B3	18-8084

O.E. #	SIERRA #	O.E. #	SIERRA #	O.E. #	SIERRA #	O.E. #	SIERRA #
MERCURY MARINE <i>cont.</i>		43994A2	18-6066A	59826A1	18-2173	75832A1	18-2104
30185Q3	18-8070	43994A2	18-6243	59826A3	18-2173	75832A1	18-2174
30185Q3	18-8084	44354A10	18-1976-2	59829A1	18-9218	75832A2	18-2104
31640A1	18-6011	44354A13	18-1976-2	59830A1	18-2146	75832A2	18-2174
31640A1	18-6011A	44354A3	18-1976-2	59830A5	18-9218	75832A3	18-2104
31640A1	18-6241	44354A9	18-1976-2	59830A7	18-2146	75832A3	18-2174
31640A2	18-6011	45518A1	18-2161	59861A1	18-1993	75832T	18-2104
31640A4	18-6011	45518A2	18-2161	59861A4	18-1993	75832T	18-2174
31640Q4	18-6011A	45518A3	18-2161	60252A2	18-4009	75832T1	18-2104
31640Q4	18-6241	45589A1	18-2169	60372A1	18-1910	75832T1	18-2174
31640T6	18-6011	45589A3	18-2169	60372A2	18-1910	75962A10	18-43052
31640T6	18-6011A	45706A1	18-2142	60426A1	18-1971	75962A11	18-43052
31640T6	18-6241	45706A12	18-2142	60427A2	18-1978	75962A9	18-43052
32170A1	18-6013	45706A14	18-2142	60932A1	18-2751	762142A1	18-6016
32193A2	18-5433	45706A3	18-2142	60932A4	18-2751	76214A5	18-6016
32489A2	18-3219	45706A4	18-2148	62092T	18-7267	76214Q5	18-60161
32492A2	18-2171	45706A6	18-2142	62351A1	18-5707	76214Q5	18-6016A
32492A3	18-2171	45706A8	18-2142	62351A2	18-5707	76214Q5	18-6244
32492A5	18-2171	46020T	18-2125	63115A12	18-7633	76214T3	18-60161
32657A3	18-9099	463999A2	18-6014	63908A2	18-1910	76214T3	18-6016A
32657A4	18-9099	46399A1	18-6014	65057A1	18-5802	76214T3	18-6244
32734A3	18-2750	46399A1	18-6014A	65057T1	18-5802	76270T	18-3552
32992A1	18-2189	47441A1	18-1977-1	65142A1	18-3593	76325A2	18-1972
33662Q	18-5345	47487T	18-5978	65603A12	18-1962-1	76351A04	18-1971
33765T	18-5386	47587A2	18-1910	65603A4	18-1962-1	76351A1	18-1971
33981T	18-2162	47638A1	18-1995	65604A12	18-1958-1	76351A2	18-1971
33981T1	18-2162	47886T	18-5808	65604A4	18-1958-1	76771A2	18-1978
33981T1	18-2162E	48752T	18-3114	66065A1	18-2157	76771A3	18-1978
34086A1	18-2189	49518A1	18-2248	66065A1	18-2159	76850A2	18-2171
34127A1	18-6012	49964A1	18-1971	66065A1	18-2190	77123A1	18-1705
34127A2	18-6012	49964A2	18-1971	66065A1	18-2190E	77234A2	18-1950-1
34127T1	18-6012	52073A1	18-1960-1	66067T	18-2286	77234A7	18-1950-1
34127T2	18-6012	52390A1	18-1955-1	66069A2	18-2157	77235A2	18-1951-1
34235Q1	18-5250	52731A1	18-7824-2	66069A2	18-2159	77235A8	18-1951-1
34235T	18-5311	52731A1	18-7876-1	66069A2	18-2190	77442A1	18-2148
34235T1	18-5250	52969A1	18-1960-1	66069A2	18-2190E	78403A1	18-5956
34762A1	18-6013	53114A1	18-2759	66081A1	18-0577	78403A1	18-5957
34765A1	18-4456	53779A1	18-1978	66081A2	18-0577	78403A2	18-5956
34765A2	18-4456	53779A2	18-1978	66081A4	18-0577	78403A2	18-5957
35187A1	18-2248	54099A1	18-1962-1	66599A1	18-7811	78458A1	18-2760
35187A2	18-2248	54099A5	18-1962-1	66599A2	18-7812	78459A1	18-1993
35187A4	18-2248	54100A1	18-1958-1	66599A3	18-7813	786214A2	18-6016
35993A1	18-0577	54100A5	18-1958-1	67914A2	18-6763	78687T	18-2144
36223A1	18-2752	54293A10	18-5822	68162A1	18-5798	78984A08	18-1993
36223A2	18-2752	54293A13	18-5822	68162A3	18-5797	78984A1	18-1993
37611A1	18-2189	54293A4	18-5822	68162A5	18-5798	79271A4	18-6763
38399A2	18-2189	55278A1	18-7807	68162A6	18-5797	79271A4	18-6768
38965A1	18-2171	55278A3	18-7809	68162A8	18-5798	79271A4	18-6799
38965A2	18-2171	55278A4	18-7809	68521A3	18-5313-1	802128A1	18-7831
39383T	18-2128	55278A5	18-7808	68521A4	18-5313-1	802371A1	18-5181
39920A1	18-1973	55538A2	18-1973	68704A1	18-1148	802630T	18-7663
41141A2	18-7284	55989A3	18-60151-9	69354A1	18-2413	802630T01	18-7663
41155A1	18-9099	55989A3	18-6015-9	69354A2	18-2413	802632T	18-33104
41155A2	18-9099	55989A3	18-6015A-9	70125A02	18-7665	802706A1	18-7738
41639A1	18-7230	55989A3	18-6242-9	70125A1	18-7665	803061T1	18-3569
41951A1	18-2157	55989A4	18-60151-9	70981A3	18-2762	803470Q	18-7878-1
41951A1	18-2159	55989A9	18-60151-9	71464A01	18-7667	803844T01	18-25513
41951A1	18-2190	55989Q9	18-60151-9	71683A1	18-3584-1	804346T1	18-7743
41951A1	18-2190E	55989Q9	18-6015-9	72436A1	18-6011	804483T	18-5354
42419A1	18-6749	55989Q9	18-6015A-9	73020A1	18-2191	805016A1	18-7234
42419A1	18-6749	55989Q9	18-6242-9	73020A14	18-2191	805025A2	18-7326
42419A1	18-6750	55989T9	18-60151-9	73020A20	18-2376	805025A2	18-8867
42431M	18-3426	55989T9	18-6015-9	73345A1	18-4233	805101T	18-3787
42724A3	18-3219	55989T9	18-6015A-9	73679A2	18-2157	805185A36	18-5471
42725A3	18-35437	55989T9	18-6242-9	73679A2	18-2159	805185A37	18-5470
42725A3	18-7282	56211A1	18-2191	73679A2	18-2190	805217A1	18-7684
42909A1	18-7818-1	57882T	18-7232	73679A2	18-2190E	805218T	18-7600
42909A2	18-7818-1	58217Q	18-5418	73723A01	18-2248	805222A1	18-5484-1
42909A3	18-7818-1	58397A2	18-6749	73723A1	18-2248	805223T	18-7702
42909A4	18-7818-1	58397A3	18-6749	73813A1	18-1990	805224A1	18-7632-1
43396A2	18-6249	58759A1	18-1960-1	73813F1	18-1990	805226A1	18-7630
43396A2	18-6249A	58759A10	18-1960-1	73873A1	18-8227	805320A03	18-7633
43432A2	18-2145	58759A13	18-1960-1	74313A4	18-1131	805320A1	18-7633
43557A1	18-5395	58759A14	18-1960-1	74436A9	18-6768	805536A1	18-2097
43567A1	18-1567	59078A1	18-3550	74436A9	18-6799	805536A2	18-2097
43567T1	18-1567	59078T3	18-3650	74639A2	18-2753-2	805544T	18-7703
43994A2	18-6066	59137A1	18-3551	74905A3	18-5313-1	805656A2	18-7326
		59341A1	18-56870	75282A1	18-4221	805656A2	18-8867

O.E. #	SIERRA #	O.E. #	SIERRA #	O.E. #	SIERRA #	O.E. #	SIERRA #
MERCURY MARINE	<i>cont.</i>	811618A1	18-6751	821630A1	18-6094A	860349A1	18-33207
805656A5	18-7326	811635Q2	18-5280	821630A1	18-6240	861006A1	18-1989
805656A5	18-8867	811635T3	18-5361	821630C2	18-6094	861155A2	18-8868
805656A6	18-7326	811636 1	18-5406	821630Q1	18-6094A	861155A3	18-8868
805656A6	18-8867	811637T	18-5107-1	821630Q1	18-6240	861155A5	18-7326
805759A1	18-5395	811639T	18-5108	821630T1	18-6094A	861155A5	18-8867
805759A2	18-5395	811673 1	18-6775	821630T1	18-6240	861155A6	18-7326
805759A5	18-5395	81242M	18-3427	821631A1	18-6066	861155A6	18-8867
805759Q3	18-5273	812454A1	18-7288-1	821631B1	18-6066	861156A02	18-8861
805759T	18-5395	812454A3	18-7288-1	821631C	18-6066	861156A03	18-8862
805759T1	18-5395	812843A1	18-6751	821631Q1	18-6066	861156A1	18-35433
805759T3	18-5273	812964A2	18-2412-1	821631Q1	18-6066A	861188A1	18-3531
805884T	18-5965	813442A1	18-6751	821631Q1	18-6243	861245A1	18-7639
80606M	18-7839	813442A2	18-6751	821759A1	18-2354	861249A1	18-7550
806105A1	18-6079	814309A1	18-2434	821759A2	18-2354	861260T	18-7692
806105A1	18-6093	814481M	18-7769	821759A3	18-2354	861493A07	18-1910
806105A1	18-6093A	814819A2	18-9218	821759A4	18-2354	861493A3	18-1910
806105Q1	18-6079	815279A2	18-5741	822777A1	18-6014	861523A9	18-2412-1
806105Q1	18-6093	815407A2	18-5396	822777A1	18-6014A	861676A1	18-35437
806105Q1	18-6093A	815425T	18-5899	822777A3	18-6014	861676T09	18-35437
806105T1	18-6079	815471A3	18-2145	822777A4	18-6014	861676T09	18-7282
806105T1	18-6093	815471A3	18-2145E	822777Q1	18-6014	861677T	18-8860
806105T1	18-6093A	815471A6	18-2145	822777Q1	18-6014A	861678A1	18-7283
806189A1	18-6067	815471A6	18-2145E	822870A1	18-6777	861678A1	18-7283
806189A1	18-6067A	815471T1	18-2604	823034T	18-5793	861771	18-5658
806189A1	18-6114	815471T1	18-2604E	823426A1	18-7072	862030T	18-5983
806189Q1	18-6114	815919A1	18-2320	823426A1	18-7077	862031T	18-6293
806189T1	18-6114	815921A2	18-2353	823427A1	18-7746	862031T1	18-6293
806190A1	18-6089	815922A1	18-2354	823653A5	18-6765	862048A1	18-7288-1
806190A1	18-6092	815922A5	18-2354	823653A9	18-6765	862077A1	18-7284
806190A1	18-6092A	815933A1	18-6080	825096T01	18-5821	862132T	18-1711
806190Q1	18-6092	815933A1	18-6099	825467A1	18-7901	86234A05	18-7278
806190Q1	18-6092A	815935A3	18-2422	825467T1	18-7901	86234A3	18-7278
806190T1	18-6089	815935A7	18-2422	826134A1	18-6068	86234A4	18-7278
806190T1	18-6092	815954A3	18-2423	826763A	18-3154	86246A1	18-7274
806190T1	18-6092A	815954A7	18-2423	828151A1	18-5849	86246T	18-7274
806191T	18-2373	816148A1	18-5313-1	828692A1	18-2382	86247A2	18-7275
806490T	18-5897	816329A3	18-1966-1	828708A1	18-6774	86247T	18-7275
806612T	18-7677	816431A1	18-2747	830250A3	18-6777	862548A1	18-6749
806673T	18-5442	816610A1	18-2244	830250T3	18-6777	862548A1	18-6750
806673T1	18-5442	816610A2	18-2244	832021A1	18-6777	863077T	18-6298
806807A1	18-7691	816770T	18-5707	832021A2	18-6777	863358T	18-43017
806867A 8	18-1956-3	817019A1	18-9099	832021T2	18-6777	86459A1	18-9099
806867A12	18-1966-1	817019A2	18-9099	832021T4	18-6777	86459A2	18-9099
806867A2	18-1966-1	817019Q2	18-9099	833232E	18-4173	864612T01	18-1842
806867A3	18-1966-1	817119A1	18-5957	835392Q	18-15147	864856A1	18-7684
806867A8	18-1966-1	817119A1	18-5965	84141M	18-7840	865202T	18-5851
806867A9	18-1966-1	817119A1	18-5966	84188M	18-3425	865380A03	18-6746
807057T	18-5851	817119A4	18-5957	84188T	18-3425	865380A13	18-6746
807074A1	18-3531	817119A4	18-5965	84262M	18-7837	865436A02	18-2157
807078Q07	18-1957-2	817119A4	18-5966	84265M	18-7838	865436A02	18-2159
807078T08	18-1957-2	817275A08	18-3406	84419M	18-7290	865436A02	18-2190
807166A3	18-2732	817275A09	18-3407	84456M	18-7770	865436A02	18-2190E
807252Q3	18-3646	817275A1	18-3571	84475M	18-7291	865436A03	18-2603
807252Q5	18-3647	817275A2	18-3572	845668T	18-0614	865436A03	18-2603E
807252T1	18-3551	817275K05	18-3147	84829M	18-3426	865437A02	18-2145
807252T2	18-3649	817275T4	18-3147	850484T	18-5362	865493A01	18-6406
807252T6	18-3646	817373A1	18-6094	850484T2	18-5362	865496A01	18-6406
807252T8	18-3647	817377T	18-5475	850484T3	18-5278	865496A01	18-6406
807476A6	18-1908K	817378T	18-5443	85147A5	18-2145	865503T	18-6404
807652T	18-5967	818298A1	18-6249	852956A1	18-7685	865510T	18-6406
807653T	18-5960	818298A1	18-6249A	853678T	18-7700	865511T	18-6406
807757T	18-6457	818298Q1	18-6249	854472A2	18-6777	866169A01	18-8864
807914A1	18-1976-2	818298Q1	18-6249A	854472A3	18-6777	866169T01	18-8864
807929A1	18-2354	818349A1	18-2286	854472A4	18-6777	866170A01	18-8865
807929A2	18-2354	818349T1	18-2286	855654A1	18-6777	86617A20	18-5864
807964A1	18-5476	818763A10	18-2376	855654T2	18-6777	86840A05	18-2756
807988A03	18-1976-2	818763A4	18-2376	855676A1	18-3642	86840A3	18-2756
807988A2	18-1976-2	818903A1	18-6777	857006T	18-6454	87290A4	18-1994
808015T	18-7553	819479A1	18-6777	85784A1	18-7228	87399A1	18-2428
808064A1	18-3531	819480A1	18-6777	85785A2	18-7231	87399A2	18-2428
808483K2	18-5291	821354A2	18-4531	85785T	18-7229	87399A3	18-2429
808483Q2	18-5281	821509T1	18-5852	859168T	18-6829	875285T1	18-6454
808483T3	18-5354	821629A1	18-6080	860235A03	18-1966-1	875286A1	18-6455
808484 1	18-5405	821629A1	18-6080A	860235A04	18-1956-3	875286T	18-6455
809463A1	18-5811	821629A1	18-6099	860246Q11	18-1953-2	87581T	18-5315-1
811536T	18-36906	821629Q1	18-6080A	860256A2	18-3530-1	878265A4	18-6773
		821630A1	18-6094	860256A4	18-3530-1	878265A6	18-6774

O.E. #	SIERRA #	O.E. #	SIERRA #	O.E. #	SIERRA #	O.E. #	SIERRA #
MERCURY MARINE cont.		8M0027721	18-2560	96863A15	18-7633	F7778A9	18-5775
880596T55	18-7338	8M0045604	18-2700	97257A1	18-5897	F8077	18-2945
880596T58	18-7346	8M0054726	18-7660	97258A1	18-5898	F8186	18-2945
881247A1	18-6455	8M0058164	18-7283	97399A2	18-7288-1	F84903	18-1162
881248T	18-6454	8M0058677	18-6157A	97401A2	18-7283	FA84901	18-1162
88183A11	18-6752	8M0060495	18-5247	97401A8	18-7283	FFF001138	18-7964-1
88183A12	18-6752	8M0061335	18-5247	97432A2	18-2414	FI000034	18-1190
88183A12	18-6753	8M0061381	18-1989	97793M	18-3426	FI1001079	18-3593
88183A5	18-6746	8M0062084	18-5408	97793T	18-3426	FI1100014	18-4492
88183A5	18-6769-1	8M0062406	18-2756	98230A1	18-73131	FI1100229	18-0348
88183A6	18-6752	8M0064021	18-6454	98502A2	18-1974-1	FI110026	18-1211
882751A04	18-5850	8M0065179	18-15148	98503A2	18-1970-2	FI110027	18-1211
882751A1	18-5849	8M0065218	18-7347	98504A3	18-1970-2	FI1100305	18-1308
882751A2	18-5849	8M0068784	18-5899	98555A1	18-5957	FI1100349	18-1402
883072T	18-5743	8M0069803	18-7663	98555A1	18-5965	FI1100381	18-1309
883166A1	18-6778	8M0072670	18-15146	98555A1	18-5966	FI1100382	18-1341
883166A2	18-6778	8M0073435	18-35437	98562A6	18-1937	FI1100386	18-3937
88475A4	18-6768	8M0074922	18-43017	98703A11	18-2424	FI1100387	18-3939
88475A4	18-6799	8M0076464	18-43017	98703A12	18-2424	FI1100399	18-1402
88479A02	18-5351	8M0084523	18-6948	98703A17	18-2424	FI110041	18-1211
88479A1	18-5351	8M0084600	18-5224	98703A26	18-2424	FI1100495	18-4492
88553A1	18-6749	8M0089715	18-3551	98703A3	18-2426	FI1100570	18-1308
88678A4	18-7633	8M0090819	18-3633	98704A11	18-2425	FI1100573	18-1309
88678A5	18-7633	8M0091470	18-3649	98704A12	18-2425	FI1100692	18-3937
888733T02	18-7336	8M0095485	18-8212-1	98704A17	18-2425	FI1100694	18-3938
888751A02	18-5350	8M0098795	18-2412-1	98704A26	18-2425	FI1100742	18-3599-2
888751A03	18-5350	8M0104229	18-3016-1	98704A3	18-2427	FI1100779	18-4161
888751A1	18-5350	8M0110717	18-2373	99155A1	18-3555	FI1100779	18-4191
888755A1	18-6158M	8M0117413	18-3640	99155T1	18-3568	FI1100780	18-4161
888755Q01	18-6158M	8M0137769	18-55505	99155T2	18-3555	FI1100780	18-4191
888756A2	18-6150A	8M0142679	18-55505	99186T	18-6273-1	FI1100781	18-4160
888756A2	18-6150Z	8M0708280	18-2425	99297A1	18-2193	FI1100783	18-3939
888756Q01	18-6158A	8M2009865	18-2130	99297A2	18-2193	FI1100785	18-3593
888756Q02	18-6150A	8M6001217	18-5338	993247A4	18-6768	FI1100853	18-1316
888756Q02	18-6150Z	8M6001218	18-5345	99356A2	18-2587	FI1100862	18-1402
888756Q4	18-6150M	8M6001219	18-5303	99370A2	18-2733	FI1100954	18-1402
888756Q4	18-6150Z	8M6001224	18-5404-1	99660A1	18-6751	FI1100968	18-4022
888757Q01	18-6159M	8M6001249	18-5347	99746A17	18-1952-1	FI1100980	18-1334
888758A1	18-6159A	8M6001250	18-5314	99746A8	18-1952-1	FI1100986	18-1233
888758Q01	18-6159A	90363A1	18-7810	99798A16	18-1956-3	FI1100997	18-3577-2
888759A1	18-6159M	90576A4	18-5432	99798A18	18-1966-1	FI1101000	18-0903
888760A1	18-6160M	90746A1	18-5395	99798A18	18-1956-3	FI1101007	18-1339
888760Q01	18-6160M	907964A1	18-5476	99798A3	18-1956-3	FI1101053	18-3577-2
888761A1	18-6160A	90806A1	18-5899	99798A9	18-1956-3	FI1101057	18-3944
888761Q01	18-6160A	91748M	18-7834	F10077105	18-2917	FI1101101	18-4189
888909A1	18-0557	91823A3	18-5313-1	F1348	18-3713	FI1101117	18-4022
88893A4	18-6749	92459A4	18-6765	F17510	18-7413	FI1101134	18-3939
88955A03	18-6454	92497A3	18-5957	F1881	18-3713	FI1101184	18-4173
89031A1	18-7811	92497A3	18-5965	F2769931	18-1402	FI1101185	18-4164
89031A2	18-7812	92520M	18-7293	F2774666	18-3593	FI1101200	18-4024
89031A3	18-7813	92975A28	18-6763	F328506	18-3937	FI1101208	18-3599-2
89031A4	18-7814	92975A32	18-6763	F328516	18-3938	FI1101222	18-1402
891736T	18-6772	92975A6	18-6763	F3746241	18-4492	FI1101236	18-2845
892864T04	18-3631	93247A4	18-6799	F3750884	18-1339	FI1101276	18-2917
892864T06	18-3635	93247A7	18-6768	F3829064	18-1316	FI1101281	18-1237
892874T01	18-8866	93247A7	18-6799	F3860315	18-25001	FI1101287	18-0664
892940T	18-5929	93320A13	18-1908K	F3866612	18-4022	FI1101291	18-2917
893640T01	18-5732	93320A2	18-1908K	F3892364	18-3937	FI1101292	18-3599-2
893929A01	18-6751	93320A3	18-1908K	F3910555	18-1308	FI1101295	18-0612
89396A38	18-8004EP-1	93320A5	18-1908K	F3916351	18-1308	FI1101296	18-0868
89396A38	18-8004S	93320A6	18-1908K	F3932344	18-0874	FI1101297	18-0976
89396Q38	18-8004EP-1	93477T	18-0615	F40109	18-2244	FI1101300	18-0519
89396Q38	18-8004S	94998A1	18-2381	F50342	18-7413	FI1101317	18-4178
896173A01	18-2700	94998A2	18-2381	F50556	18-2945	FI1101318	18-4173
897755T	18-6840	94998A3	18-2381	F508814	18-1129	FI1101320	18-4164
898101T67	18-7337	94998A4	18-2381	F5232670	18-1402	FI1101321	18-3937
898253T22	18-5244	95661M	18-3427	F532555	18-7467	FI1101322	18-3938
898253T23	18-5243	95755A2	18-1970-2	F53795	18-7153	FI1101334	18-4173
898253T24	18-5433	95862A5	18-1954-1	F6269358	18-3577-2	FI1101336	18-4164
898253T27	18-5443	95864A2	18-1975-1	F694555	18-7176	FI1101656	18-0322
898253T28	18-5246	96184A1	18-1567	F694961	18-2346	FI1110294	18-25001
898253T29	18-5247	96455A1	18-5797	F700633	18-4263	FI1110958	18-25001
89876A3	18-7853-1	96455A15	18-5796	F7040	18-3700	FI5000074	18-0889
899106T01	18-8866	96455A6	18-5798	F720301	18-5881	FI5000077	18-0891
		96455A8	18-5797	F724073	18-1300	FI5000078	18-0891
		96455A9	18-5798	F724102	18-1401	FI5000096	18-2917
		96477A3	18-6752	F74305	18-7176	FI5000119	18-2815
		96705A1	18-1955-1	F749301	18-5775	FI5000161	18-2845

O.E. #	SIERRA #	O.E. #	SIERRA #	O.E. #	SIERRA #	O.E. #	SIERRA #
MERCURY MARINE cont.		346871220M	18-7291	125530	18-2881	303069	18-3103
FI5000162	18-0874	346873217M	18-74611	127084	18-4222	303191	18-7413
FI5000178	18-0411	353650210M	18-45404	160084	18-1501	303339	18-2891
FI5000183	18-0411	353760104M	18-6418	171960	18-5898	303345	18-2022
FI5000199	18-2815	369022300M	18-7712	172521	18-5011	303347	18-7180
FI5000200	18-0327	369871221M	18-7765	172522	18-5006	303355	18-2892
FI5000201	18-0887	398873213M	18-74610	172523	18-5002	303360	18-7117
FI5000204	18-2946	3AA050040M	18-51000	172525	18-5001	303438	18-2885
FI5000219	18-0327	3B2-70260-0	18-8089	172527	18-5250	303598	18-7150
FI5000229	18-0348	3B2650160M	18-43212	172531	18-5256	303615	18-0850
FI5000232	18-0868	3B2650211M	18-8920	172543	18-6762	303750	18-2893
FI5000245	18-0348	3B2702501M	18-8088	172543	18-6822	303804	18-2060
FI5000263	18-0868	3B2702810M	18-8079	172588	18-6816	304023	18-2880
FI5005756	18-0876	3B2873222M	18-48317	172806	18-5003	304026	18-3332
FI5110032	18-0153	3B7650212M	18-8924	172850	18-6767-1	304174	18-7165
FI5110037	18-0153	3B7871218M	18-4436	172869	18-5814	304314	18-2894
FI5810151	18-4263	3C7650211M	18-8924	173029	18-6017	304720	18-2951
FI5880010	18-4264	3C8-87121-4	18-4434	173029	18-6017A	304762	18-2871
FI6900023	18-5347	3C8010055M	18-3850	173029	18-6100	304764	18-0882
FI6900031	18-5303	3C8650212M	18-8922	173231	18-7875	305123	18-7133
FI6900031	18-5345	3C8750140M	18-56002	173233	18-7876-1	305176	18-2870
FI6900032	18-5347	3C8760101M	18-6432	173311	18-8055	305185	18-7826
FI6900040	18-5338	3FO-06153-0	18-5182	173312	18-8074	305242	18-7118
FI6900044	18-5407	3FO060491M	18-5182	173326	18-7930	305270	18-7155
FI6900052	18-5385	3FO061530M	18-5182	173564	18-6767-1	305303	18-3102
FI6900083	18-5347	3F3010051M	18-4299	173596	18-6767-1	305306	18-2027
FI6900148	18-5376	3F3871210M	18-4435	173619	18-5251	305312	18-2869
FI6900152	18-5898	3G2-06040-2	18-5166	173690	18-5258	305739	18-7101
FI6900184	18-5369	3GR702500M	18-80410-1	173829	18-5260	305762	18-2532
FI6900185	18-5352	3M3060482M	18-5166	173834	18-7879-1	305987	18-2018
FI6900186	18-5403	3R0-07615-0	18-7911-1	173944	18-6816	306048	18-2959
FI6900189	18-5347	3R0074220M	18-76695	174177	18-8072	306205	18-2901
FI6900190	18-5403	3R3010300M	18-43175	174275	18-9013	306643	18-3135
FI6900198	18-5898	3T9010050M	18-3886	174275	18-9024	307069	18-2957
FI6901224	18-5404-1	3V1010050M	18-60916	174275	18-9065	307082	18-7152
FI8390006	18-7860	3V1010240M	18-60917	174275	18-9080	307103	18-7428
FI9608751	18-7964-1	3V1013030M	18-60918	174448	18-9098	307133	18-2876
FT8935	37509	3V1023050M	18-60919	174508	18-8056	307239	18-7170
MC 1 95862	18-1954-1	3V1060400M	18-23207	174509	18-8014EP-2	307257	18-2872
RA122009	18-5603	3V1871210M	18-64221	174509	18-8014S-1	307450	18-7102
YLM579AV	18-5497-2	65750-95500	18-8079	174511	18-8004EP-1	307551	18-2387
MERCURY/MERCUISER		B29A-90500A	18-6430	174511	18-8004S	307551	18-23871-9
339-883778A01	18-5159	OBERDORFER		174512	18-8005EP-1	307551	18-4255
339-883778A02	18-5159	6603	18-3021	174512	18-8005S	307552	18-2945
339-8M0077473	18-5159	7054	18-3078	175068	18-9013	307573	18-6501
879984A1	18-5158	8922	18-3061	175068	18-9024	307583	18-7106
879984T00	18-5158	132-0317	18-3060	175068	18-9065	307853	18-7120
879984T01	18-5158	B6620	18-3075	175068	18-9080	308186	18-4075
8M0077471	18-5158	C7441	18-3077	175158	18-0871	308458	18-7461
MOTOROLA		OETIKER		175266	18-3715	308500	18-8351
510-802	18-5976	787133	18-9125	175267	18-3716	308621	18-7121
510-821	18-5976	14100082	18-9141	175268	18-3717	308624	18-7103
510-835	18-5976	16700004	18-9126-9	176288	MP28890	308626	18-7198
510-836	18-5976	16700006	18-9127-9	176445	18-8092	308627	18-7104
510-845	18-5975	16700007	18-9128-9	202893	18-7168	308799	18-2863
510-856	18-5976	16700010	18-9129-9	203034	18-2952	308825	18-0653
510-860	18-5975	16700011	18-9130-9	203130	18-3841-2	308876	18-7123
510-861	18-5976	16700012	18-9131-9	203171	18-2886	308928	18-3108
510-862	18-5976	16700013	18-9132-9	203698	18-6513	309044	18-2534
510-864	18-5975	16700016	18-9133-9	277181	18-3001	309243	18-1236
9AR3743G	18-5976	16700017	18-9134-9	300599	18-2035	309612	18-2950
9AR3855G	18-5975	16700020	18-9140-9	300611	18-3326	309731	18-7156
9AR3959G	18-5975	16700024	18-9135-9	301824	18-7111	309955	18-3741
9AR6000G	18-5975	16700031	18-9136-9	301877	18-7100	309956	18-2898
NISSAN		16700037	18-9137-9	301967	18-7440-1	309989	18-2000
3G3060211M	18-5165	16700040	18-9138-9	302325	18-3369	310058	18-0182
NISSAN-TOHATSU		16700053	18-9139-9	302337	18-7162	310137	18-2868
332600052M	18-72656	OMC		302493	18-7112	310327	18-7173
332600060M	18-60103	114812	18-45312	302497	18-3329	310414	18-7167
332600060M	18-72656	121731	18-3722	302537	18-7164	310584	18-7135
334650210M	18-8921	122838	18-8052	302540	18-7114	310585	18-7158
345650210M	18-8923	123009	18-6017	302557	18-2887	310599	18-2012
345871224M	18-7290	123009	18-6017A	302588	18-7115	310649	18-2020
346-01032-0	18-60920	123009	18-6100	302675	18-2889	310913	18-2947
346760100M	18-6431	123018	18-1599	302804	18-3740	310953	18-15460
		124249	18-8201	302994	18-2890	310967	18-7158
				303059	18-7134	311046	18-15440
				303067	18-7116		

O.E. #	SIERRA #	O.E. #	SIERRA #	O.E. #	SIERRA #	O.E. #	SIERRA #
	OMC cont.	316706	18-4914	320880	18-1219	324639	18-2034
311068	18-2896-1	317178	18-7109	320936	18-0540	324670	18-0110
311069	18-0164	317201	1525607	320943	18-2704	324701	18-2557
311121	18-2861-1	317232	18-2234	320961	18-8353	324717	18-0112
311130	18-2860	317245	18-1243	320981	18-3343	324766	18-0198
311131	18-2859	317305	18-0951	321008	18-2706	324825	18-8204
311145	18-0679	317624	18-1279	321027	18-3563	324937	18-2537
311210	18-3880	317831	18-4290	321028	18-2544	324981	18-7481
311338	18-7105	317838	18-2219	321117	18-7141	325092	18-0118
311508	18-0917	317841	18-3182	321120	18-2536	325211	18-0120
311598	18-4248	317843	18-2026	321163	18-7510	325260	18-0122
311598	18-42481-9	317914	18-2866	321182	18-2545	325273	18-3800
311606	18-15400	317951	18-0953	321183	18-0979	325398	18-3352
311684	18-7854	317955	18-0117	321184	18-2546	325537	18-0124
312456	18-7860	318156	18-0955	321220	18-3565	325647	18-3801
312634	18-2879	318223	18-2059	321221	18-3567	325721	18-2907
312679	18-2900	318303	18-2209	321222	18-3562	326260	18-2862
312780	18-0874	318304	18-2208	321435	18-2549	326264	18-0126
312781	18-71337	318334	18-2872	321459	18-2027	326468	18-0128
312797	18-0398	318335	18-2873	321467	18-2060	326649	18-7174
312797	18-2917	318358	18-2956	321479	18-0981	326716	18-0174
312800	18-0876	318372	18-7137	321481	18-2029	326741	18-7418
312932	18-6511	318373	18-0957	321497	18-0983	326751	18-2075
313065	18-2901	318395	18-3564	321504	18-8351	326765	18-4292
313080	18-2767	318544	18-2378	321573	18-2862	326849	18-7144
313175	18-7107	318544	18-23781-9	321648	18-5655	326877	18-6509
313176	18-3141	318544	18-4249	321692	18-2391	326926	18-1212
313244	18-0923	318609	18-2543	321722	18-0985	326953	18-2888
313258	18-2021	318717	18-7138	321724	18-70936	327031	18-2035
313282	18-2023	318841	18-4222	321727	18-2864	327035	18-2392
313283	18-0173	318914	18-2963	321786	18-2030	327606	18-6018
313284	18-2005	318917	18-0397	321787	18-2031	327655	18-1289
313340	18-7126	318924	18-0959	321788	18-2032	327656	18-0200
313353	18-2058	318925	18-2853	321794	18-0989	327674	18-3899
313368	18-2851	318932	18-0961	321830	18-8304	327707	18-0134
313413	18-2960	318940	18-1505	321831	18-0542	327795	18-3802
313416	18-0929	318944	18-6503	321886	18-3290	327861	18-4280
313446	18-7127	318971	18-3706	321895	18-0543	328283	18-0136
313448	18-1714	318972	18-2025	321907	18-0991	328313	18-1288
313507	18-0543	318973	18-2028	321921	18-7411	328360	18-9885
313754	18-7128	318995	18-3178	321928	18-2033	328361	18-9886
313763	18-2865	319085	18-7139	321932	18-0675	328363	18-9887
313782	18-2884	319097	18-2913	321940	18-3126	328364	18-9888
313893	18-7108	319126	18-3369	322119	18-7133	328365	18-9889
313992	18-2016	319174	18-2867	322119	18-7142	328366	18-9890
314008	18-2703	319256	18-2029	322236	18-4911	328367	18-9891
314082	18-2855	319275	18-3127	322332	18-2962	328506	18-3937
314115	18-0933	319332	18-0967	322411	18-0892	328516	18-3938
314167	18-2024	319348	18-2904	322501	18-7143	328536	18-3940
314322	18-0935	319586	18-0969	322652	18-8020	328590	18-0138
314421	18-2877	319633	18-2954	322653	18-8200	328603	18-8350
314491	18-7129	319661	18-0971	322654	18-8202	328604	18-0140
314502	18-3742	319662	18-7457	322656	18-8051	328622	18-0142
314503	18-3705	319664	18-2093	322858	18-2547	328623	18-3837
314728	18-7130	319665	18-2856	322941	18-3763	328626	18-0144
314730	18-3719	319710	18-2878	323214	18-2550	328751	18-3358
314731	18-0195	319771	18-2857	323217	18-0945	328753	18-2539
314745	18-2231	319890	18-4229	323222	18-0995	328755	18-3359
314809	18-2858	319891	18-3707	323311	18-0446	329076	18-0441
314832	18-2389	319895	18-2287	323312	18-0445	329103	18-2961
314876	18-2874	320041	18-2379	323361	18-2230	329380	18-7416
315052	18-0973	320140	18-7178	323362	18-2229	329381	18-7417
315055	18-0937	320166	18-2224	323459	18-0999-9	329390	18-3360
315189	18-0939	320167	18-2225	323469	18-0102	329419	18-3803
315232	18-7296	320168	18-2226	323582	18-8372	329653	18-8203
315288	18-0542	320169	18-2227	323626	18-3136	329654	18-8034
315538	18-0941	320170	18-2228	323653	18-6522	329718	18-0148
315539	18-2958	320303	18-7140	323664	18-2220	329826	18-0851
315748	18-2705	320305	18-4230	323889	18-2232	329828	18-1205
315810	18-4228	320311	18-2398	323890	18-2233	329830	18-1202
315837	18-3337	320499	18-1377	323943	18-4232	329833	18-1207
315868	18-1218	320533	18-2963	324097	18-3179	329836	18-3836
315869	18-1224	320570	18-4231	324323	18-0106	329920	18-2905
316499	18-0949	320630	18-2220	324324	18-3803	329922	18-2061
316506	18-2243	320658	18-3802	324334	18-4276	329923	18-2062
316563	18-2377	320745	18-2964	324369	18-2399	330081	18-4076
316705	18-4913	320785	18-3743	324430	18-4277	330137	18-2001
		320862	18-2002	324449	18-0108	330273	18-1221

O.E. #	SIERRA #	O.E. #	SIERRA #	O.E. #	SIERRA #	O.E. #	SIERRA #
	OMC cont.	335679	18-2279	379628	18-2192	385662	18-3906
330327	18-2063	335722	18-2277	379763	18-3201	385781	18-7352
330412	18-0155	335818	18-1283	379766	18-3203	385952	18-5697
330525	18-6512	335819	18-1284	379777	18-7801	386084	18-3050
330560	18-3363	335981	18-1507	379957	18-4218	386124	18-3384
330619	18-3295	336232	18-1286	380186	18-7071	386280	18-3933
330621	18-2852	336430	18-0945	380537	18-5345	386430	18-6434
330698	18-0157	336530	18-2709	380538	18-5311	386533	18-3388
330818	18-2963	336562	18-2216	380541	18-5385	386545	MP39100
330854	18-1391	336982	18-42531-9	380542	18-5419	386545	MP39830
330909	18-0159	336982	18-4253-9	380543	18-5310	386573	18-2857
331103	18-8307	337020	18-1290	380640	18-3593	386591	18-5629
331107	18-3299	337068	18-0412	380986	18-7258	386657	18-5648
331188	18-7143	337772	18-2216	381389	18-7200	386659	18-2355
331203	18-2890	337774	18-2216	381494	18-7609-1	386697	18-3327
331211	18-3838	337778	18-1500	381538	18-3059	386764	18-1354
331353	18-7963	338484	18-2557	381668	18-7608-1	386765	18-1355
331363	18-2879	338518	18-7108	381690	18-7860	387041	18-1353
331380	18-7150	338534	18-6522	382045	18-7043	387094	18-5640
331499	18-2908	338813	18-2582	382046	18-7043	387139	18-4040
331532	18-0161	338876	18-2879	382047	18-7043	387142	18-4040
331598	18-0978	338878	18-2908	382049	18-7043	387247	18-1158
331880	18-3765	338879	18-2900	382050	18-7010	387262	18-7093
331916	18-2913	338880	18-2903	382051	18-7010	387277	18-6761
331917	18-2938	338882	18-2579	382052	18-7024	387284	18-4124
331979	18-3133	338884	18-2906	382053	18-7024	387285	18-4114
331980	18-1704	338886	18-2890	382054	18-7010	387326	18-3325
331999	18-4826	339620	18-2074	382057	18-7026	387361	18-3090
332000	18-2769	340115	18-3866	382125	18-5344	387610	18-3327
332010	18-2888	340490	18-2219	382133	18-5375	387656	18-1365
332108	18-2548	340619	18-3455	382135	18-5314	387661	18-4062
332205	18-2064	340975	18-70936	382136	18-5338	387683	18-5674
332253	18-8352	340976	18-70937	382138	18-6754	387684	18-5630
332261	18-2065	341013	18-1598	382218	18-3599-2	387684	18-5630
332266	18-0130	341280	18-8300	382221	18-45221	387787	18-1361
332319	18-0987	341281	18-8301	382296	18-3402	387817	18-1117
332369	18-0977	341440	18-9892	382343	18-1356	387818	18-2252
332403	18-2881	341501	18-0628	382354	18-7352	387879	18-2250
332489	18-2309	342786	18-8325	382363	18-7210	388268	18-7352
332491	18-2308	342787	18-8326	382385	18-3557	388344	18-1378
332584	18-7475	343863	18-1207	382407	18-1351	388517	37478
332585	18-0559	344470	18-3295	382408	18-1366	388602	18-4301
332598	18-7120	346004	18-1723	382468	18-3377	388644	18-3393
332694	18-2900	346150	18-9140-9	382547	18-3082	388644	18-3403
332696	18-2903	346151	18-9135-9	382715	18-6822	388891	18-3238
332816	18-3895	346152	18-9136-9	382733	18-7609-1	389039	18-1358
332817	18-3896	346153	18-9137-9	382821	18-7605-1	389042	18-1370
332819	18-3898	346785	18-9132-9	383052	18-7043	389112	18-3327
333008	18-0975	346786	18-9133-9	383067	18-7043	389143	18-3388
333077	18-2219	346930	18-9126-9	383087	18-7201	389206	18-4307
333096	18-2093	346931	18-9131-9	383307	18-3554	389275	18-5630
333418	18-2906	347107	18-9129-9	383440	18-5711	389275	18-5630
333572	18-7145	347108	18-9130-9	383444	18-5437	389289	18-3059
333592	18-4223	348838	18-9127-9	383587	18-5384	389556	18-4303-1
333670	18-3839	348839	18-9134-9	383615	18-7070	389576	18-3091
333725	18-0197	349516	18-9128-9	383766	18-7605-1	389589	18-3055
333758	18-2708	349729	18-9139-9	383918	18-7095	389642	18-3043
333771	18-0201	349759	18-9138-9	384087	18-3336	389954	18-5634
333879	18-0965	349957	18-9876	384163	18-5630	390055	18-7046
333957	18-1343	352165	18-0313	384163	18-5630	390076	18-4318
334163	18-3766	352670	18-0465	384194	18-7605-1	390078	18-4302
334353	18-0437	353076	18-2075	384195	18-1357	390082	18-3972
334516	18-2216	357159	18-0153	384719	18-3560	390286	18-3366
334665	18-4197	357159	18-0411	384735	18-5418	390381	18-3379
334726	18-3839	370409	18-3944	384743	18-7072	390509	18-3907
334742	18-1734	375638	18-3002	384777	18-5648	390510	18-3908
334897	18-3138	377139	18-1154	384781	18-5671	390641	18-1396
334913	18-7150	377178	18-3003	384848	38653	390770	18-3380
334950	18-8367	377230	18-3083	384884	37509	390905	22355
335334	18-7796	378065	18-3543	384956	18-3376	390928	79040
335359	18-3802	378231	18-5437	385043	18-1371	391170	18-3913
335360	18-2964	378444	18-5807	385068	18-1367	391264	18-6759
335361	18-3801	378891	18-3006	385072	18-3044	391300	18-4303-1
335403	18-1285	378895	18-7093	385356	18-7024	391305	18-7223
335523	18-7110	379312	18-7093	385391	18-5753	391416	18-3915
335633	18-0963	379313	18-7094	385416	18-4300	391472	18-2187
335677	18-9219	379475	18-3086	385503	18-1395	391511	18-5619
		379504	18-1350	385529	18-5634	391635	18-3378

O.E. #	SIERRA #	O.E. #	SIERRA #	O.E. #	SIERRA #	O.E. #	SIERRA #
	OMC cont.	396349	18-2660	432956	18-3387	436888	18-2252
391638	18-7350	396350	18-2656	432962	18-7822	436891	18-4323
391653	18-4101	396351	18-2658	432969	18-4065	436954	18-3129
391698	18-3327	396352	18-2657	432970	18-4066	436957	18-3389
391698	18-3400	396355	18-2659	433003	18-4067	437059	18-3104-1
391735	18-5648	396377	18-3910	433004	18-4068	437090	18-3545
391937	18-7223	396378	18-3911	433017	18-2251	437228	18-0993
391988	18-4304-1	396379	18-3912	433067	18-1721	437327	18-7248
392061	18-7042	396503	18-3906	433190	18-79781	437409	18-4063
392061	18-7222	396504	18-3905	433226	18-6285	437801	18-6280
392123	18-6027	396520	18-7093	433379	18-3643	437907	18-3491
392133	18-5629	396521	18-7093	433386	18-7353	438039	18-1702
392455	18-4123	396522	18-7094	433387	18-7352	438040	18-1703
392462	18-6026	396583	18-4104	433458	18-6025	438399	18-1722
392475	18-1287	396585	18-4100	433503	18-1299	438529	18-6780
392550	18-7046	396587	18-4103	433519	18-7800	438531	18-6780
392567	18-4307	396588	18-4100	433548	18-3394	438555	18-7353
392615	18-4307	396644	18-4529	433549	18-3394	438556	18-7352
392621	18-4107	396701	18-7042	433550	18-2694	438562	18-7351
393023	18-6024	396701	18-7222	433580	18-6115	438591	18-3129
393023	18-6024A	396725	18-3053-1	433935	18-3015	438591	18-3389
393061	18-0466	396750	18-4310	433941	18-4307	438592	18-3394
393088	18-7823	396809	18-3368	434063	18-2218	438592	18-3454
393103	18-7820	396852	18-3015	434107	18-3913	438616	18-7800
393159	18-0153	396932	18-3385	434109	18-3915	438786	18-6281
393271	18-4120	396933	18-3399	434137	18-3500	438996	18-7247
393279	18-9894	396987	18-3557	434381	18-4309	439015	18-4195
393301	MP39760	397003	18-6525	434400	18-1703	439071	18-7043
393433	18-4305	397004	18-6526	434421	18-3390	439072	18-7223
393509	18-3381	397023	18-5619	434421	18-3392	439073	18-7219
393561	18-0927	397131	18-3059	434424	18-3001	439076	18-7046
393566	18-4122	397274	18-7350	434496	18-6780	439077	18-3378
393570	18-5628	397537	18-1363	434588	18-1729	439077	18-3399
393612	18-4102	397538	18-1364	434839	18-7916	439078	18-7248
393630	18-3382	397541	18-2288	434841	18-3543	439079	18-7248
393632	18-3367	397627	18-2310	434844	18-1376	439138	18-2288
393659	18-3543	397768	18-6029	434888	18-7046	439141	18-2623
393896	18-1393	397839	18-7350	435022	18-2251	439476	18-4807
393924	18-4120	398042	18-3708-1	435027	18-3346	439515	18-4165
393988	18-6759	398047	18-4321	435096	18-1703	439516	18-4086
394176	18-6759	398051	18-2093	435276	18-4841	439517	18-4087
394394	18-3401	398319	18-7831	435277	18-4840	439538	18-3947
394408	18-1222	398327	18-7830	435279	18-4843	439561	18-5828
394409	18-3500	398331	18-6025	435390	18-3180	439937	18-6281
394411	18-1506	398338	18-7352	435442	18-7221	439948	18-3059
394461	18-4063	398387	18-7352	435442	18-7247	439967	18-2672
394462	18-1752	398452	18-7223	435443	18-7046	458625	18-0153
394488	18-4148-1	398453	18-7223	435447	18-3390	458625	18-0411
394534	18-3059	398483	18-4064	435491	18-3544	473424	18-1211
394543	18-7352	398514	18-7821	435548	18-6277	500421	37477
394546	18-4306	398526	18-7046	435673	18-3129	500422	37478
394711	18-3327	398532	18-7043	435676	18-7248	500423	37479
394711	18-3400	398549	18-8009EP-2	435677	18-7248	502036	18-1402
394885	18-4309	398549	18-8009S-1	435678	18-7248	502867	18-8063
394930	18-3904	398602	18-1282	435748	18-3059	502880	18-5196
395060	18-3390	398729	18-7042	435752	18-7248	502881	18-5172
395072	18-3391	398729	18-7222	435760	18-2325	502888	18-5192
395073	18-3393	398901	18-1368	435761	18-2328	502890	18-5194
395091	18-7350	431708	18-6095	435821	18-3059	502900	18-7875
395204	18-5825	431708	18-6095A	435929	18-3315-2	502901	18-7876-1
395207	18-5640	431844	18-3974	435957	18-3501	502903	18-7879-1
395209	18-2187	431870	18-3975	435959	18-3405	502904	18-7878-1
395270	18-3383	431897	18-7219	436137	18-8906	502905	18-7846
395270	18-3401	432072	18-4065	436195	18-3561	502905	18-7946
395271	18-3401	432073	18-4066	436232	18-2326	502906	18-7789
395289	18-3051	432077	18-4067	436234	18-2327	502906	18-7989
395419	18-5808	432078	18-4068	436235	18-2330	503747	18-8807-1
395460	18-6501	432230	MP28880	436254	18-3901	503748	18-8800-1
395627	18-1374	432230	MP28900	436353	18-4088	503749	18-8811-1
395713	18-7352	432230	MP28902-1	436354	18-4090	503749	18-8814-1
395861	18-1753	432264	18-1369	436367	18-5886	503749	18-8841-1
395864	18-3059	432451	18-7352	436740	18-2251	503750	18-8801-1
395867	18-7821	432570	18-4322	436745	18-6024	503751	18-8810-1
395911	18-6527	432803	18-4069	436745	18-6024A	503752	18-8802-1
396041	18-1360	432925	18-5612	436746	18-2218	503752	18-8803-2
396161	18-6528	432941	18-3104-1	436834	18-1725	503752	18-8823-1
396235	18-5619	432955	18-3129	436859	18-4079	503753	18-8842-1
		432955	18-3389	436860	18-4190	503754	18-8820-1

O.E. #	SIERRA #	O.E. #	SIERRA #	O.E. #	SIERRA #	O.E. #	SIERRA #
OMC cont.		583266	18-5832	586286	18-5612	908194	18-7400
503755	18-8802-1	583298	18-5170	586287	18-5612	908237	18-3881
503755	18-8803-2	583380	18-5758	586288	18-5640	908383	18-7401
503755	18-8823-1	583408	18-5708	586343	18-5884	908611	18-2946
503756	18-8843-1	583473	18-5627	586661	18-5781-1	908717	18-0183-1
508105	18-2613	583476	18-5893	586667	18-5893	908765	18-0435
508180	MP39760	583482	18-5624	586696	18-5764	908852	18-2071
508235	1525607	583605	18-5891	586730	18-5801	908894	18-2072
508626	18-3543	583689	18-5832	586731	18-5619	908929	18-15455
508871	18-0348	583737	18-5176	586774	18-5833	908935	18-2850-1
508872	18-0407	583740	18-5170	586842	18-5801	909048	18-7477
508876	18-0411	583748	18-5766	678882	18-7093	909121	18-2183
509395	18-7278	583865	18-5885	740120	18-1922	909314	18-2902-1
509404	18-7283	583896	18-5794	763364	18-7903	909314	18-2902-1-9
509407	18-7282	584028	18-5770-1	763735	18-3090	909316	18-7403
509408	18-7284	584032	18-5771	763793	18-5782	909515	18-0548
509409	18-7274	584037	18-5893	763794	18-5783	909527	18-2768
509410	18-7275	584041	18-5772-1	763794	18-5784-1	909529	18-0947
510364	18-5224	584107	18-6761	763803	18-5774-1	909533	18-3365
510883	18-5226	584122	18-5886	764354	18-9530-3	909613	18-0418
552906	18-3744	584128	18-5813	764357	18-9540-3	909747	18-7404
553126	18-7172	584329	18-5794	764708	18-5755	909748	18-0188
554545	18-7146	584331	18-5794	765012	18-3803	909753	18-2185
580148	18-5156	584416	18-5705	765350	18-3104-1	909758	18-0434
580256	18-5200	584424	18-5832	766779	18-2964	909786	18-0943-2
580290	18-5157	584476	18-5827	766870	18-2950	909818	18-15500
580321	18-5199	584477	18-5181	771839	18-7920	909829	18-0549
580339	18-5750	584488	18-5883	772577	18-4911	909830	18-0550
580740	18-5193	584489	18-5794	772578	18-4913	909835	18-0891
581027	18-5750	584561	18-5176	772579	18-4914	909863	18-1921
581032	18-5194	584580	18-5823	772584	18-5226	909971	18-15460
581130	18-5163	584632	18-5194	772681	18-8063	910048	56507
581207	18-5141	584636	18-5781-1	772681	18-8063	910113	18-0673
581311	18-5753	584641	18-5831	772831	18-7609-1	910139	18-7855
581397	18-5755	584642	18-5773	775518	18-3002	910169	18-5399
581407	18-5196	584643	18-5877	775519	18-3003	910236	18-2911
581419	18-5205	584783	18-5767	775521	18-3006	910305	18-75100
581528	18-5814	584799	18-5619	775613	18-9013	910343	18-15415
581610	18-5192	584818	18-5631	775613	18-9024	910380	18-1922
581713	18-5757	584890	18-5826	775613	18-9065	910384	18-4009
581726	18-5754	584908	18-5768	775613	18-9080	910414	18-15380
581731	18-5753	584980	18-5632	775640	18-8056	910582	18-7174
581778	18-5709	584981	18-5878	775641	18-8092	910641	18-7792
581786	18-5172	584985	18-5887	777120	18-9540-7	910995	18-2216
581805	18-5759	585001	18-5827	777130	18-3086	911019	18-2066
582048	18-6761	585050	18-5648	777213	18-3083	911311	18-7406
582056	18-5756	585051	18-5634	777228	18-9530-7	911616	18-8021
582057	18-5757	585056	18-5624	778885	18-7915-1	911662	18-02062
582091	18-5192	585057	18-5634	778886	18-7896	911663	18-02063
582125	18-5759	585058	18-5648	778887	18-7897	911665	18-02065
582138	18-5760	585059	18-5627	778888	18-7895	911666	18-02066
582155	18-6761	585060	18-5628	778992	18-5640	911667	18-02067
582160	18-5194	585061	18-5629	778994	18-5628	911668	18-0207
582261	18-5764	585062	18-5640	778995	18-5617	911669	18-0209
582285	18-5763	585063	18-5630	778996	18-5631	911669	18-0211
582365	18-5231-1	585114	18-5781-1	787133	18-9125	911670	18-0209
582365	18-8815-1	585134	MP28870	787145	18-9125	911670	18-0211
582365	18-8816-1	585145	18-5774-1	787145	18-9141	911671	18-0209
582365	18-8818-1	585189	18-5780	797407	18-3015	911671	18-0211
582366	18-5176	585219	18-5828	907761	18-0114-1	911672	18-0209
582382	18-5193	585261	18-5785	907764	18-0104	911672	18-0211
582399	18-5708	585267	18-5679	907774	18-3111	911673	18-0209
582400	18-5760	585269	18-5678	907775	18-2883-1	911673	18-0211
582452	18-5758	585459	18-5627	907866	18-3731	911674	18-0209
582453	18-5758	585995	18-5831	907932	18-2830-1	911674	18-0211
582472	18-5705	586000	18-5832	907967	18-2073	911675	18-0209
582508	18-5179	586048	18-5829	908013	18-2875-1	911675	18-0211
582556	18-5760	586075	18-5830	908013	18-2875-1-9	911676	18-0209
582642	18-5760	586212	18-5781-1	908034	18-7859	911676	18-0211
582705	18-5782	586217	18-5893	908062	18-4251	911677	18-0209
582708	18-5808	586224	18-5705	908063	18-2176	911678	18-0211
582811	18-5783	586271	18-5831	908064	18-3725	911678	18-0227
582811	18-5784-1	586274	18-5617	908065	18-2071	911679	18-0229
582995	18-5181	586277	18-5631	908069	18-2177	911680	18-02060
583110	18-5784-1	586279	18-5624	908070	18-2072	911681	18-02061
583114	18-5761	586281	18-5648	908079	18-2912-1	911685	18-2067
583170	18-5763	586284	18-5632	908087	18-2184	911686	18-7169
		586285	18-5628	908158	18-3153	911693	18-1701

O.E. #	SIERRA #	O.E. #	SIERRA #	O.E. #	SIERRA #	O.E. #	SIERRA #
OMC cont.		914743	18-0654	982277	18-6019	984748	18-7634
911698	18-0911	914787	18-15450	982336	18-5369	984765	18-4806
911700	18-7407	914816	18-4161	982342	18-5411	984770	18-4804
911701	18-2068	914817	18-1213	982352	18-7018	984771	18-4805
911702	18-2916	914820	18-1239	982364	18-5957	984876	18-3578
911703	18-3121	914849	18-3877	982384	18-7070	984982	18-5908
911704	18-2541	914899	18-1848	982422	18-1099	985050	18-2218
911705	18-0166	914930	18-3879	982424	18-2186	985052	18-7017
911718	18-7408	914971	18-3876	982438	18-6019	985063	18-5812
911734	18-4837	915025	18-2909	982515	18-3584-1	985064	18-5801
911750	18-4828	915236	18-4160	982517	18-3584-1	985083	18-3937
911751	18-3768	915272	18-2383	982537	18-7081	985218	18-5397
911752	18-3610	915325	18-3887	982539	18-7096	985237	18-6759
911753	18-3769	915326	18-0468	982554	18-3558	985316	18-1401
911787	18-2138	915702	18-2068	982650	18-5899	985429	18-3599-2
911795	18-8349	915716	18-2104	982706	18-6755	985518	18-2674
911797	18-2533	915717	18-2174	982880	18-5403	985560	18-5313-1
911820	18-4250	915719	18-0440	982946	18-2665	985602	18-7278
911823	18-2996	915720	18-4833	982947	18-2664	985603	18-7278
911826	18-2763	915735	18-5433	982949	18-2667	985612	18-2671
911836	18-2918	915840	18-2918	982997	18-7289	985613	18-2672
911844	18-3145	916058	18-2068	983195	18-6257	985630	18-0868
911851	18-7153	916096	18-1922	983218	18-3386	985822	18-7615-1
911871	18-7409	916262	18-0183-1	983247	18-6842	985902	18-5890
911878	18-0880	976669	18-6020	983296	18-3577-2	985966	18-5911
911937	18-3770	979659	18-7072	983298	18-3119	986007	18-5908
912029	18-4835	979719	18-7080	983318	18-6764	986074	18-3577-2
912157	18-0190	979774	18-5803	983424	18-6841	986103	18-0410
912164	18-1204-1	980014	18-1712	983424	18-6842	986104	18-0410
912164	18-1204-1-9	980152	18-5386	983444	18-5911	986120	18-21752-1
912212	18-2146	980183	18-2156	983494	18-6101	986232	18-21754
912213	18-2128	980477	18-3599-2	983538	18-7081	986280	18-6779
912214	18-2104	980528	18-7608-1	983790	18-5911	986336	18-3937
912227	18-3879	980530	18-7609-1	983825	18-1600	986338	18-21751
912374	18-2745	980613	18-5897	983826	18-1601	986364	18-2673
912405	18-0956-1	980617	18-1876	983836	18-6841	986380	18-4806
912418	18-15500	980803	18-5903	983836	18-6842	986381	18-4804
912424	18-75100	980892	18-5407	983855	18-7615-1	986382	18-4805
912441	18-1902	980893	18-5303	983864	18-7095	986423	18-2674
912442	18-1903	980894	18-5347	983870	18-7855	986505	18-5910
912471	18-0431	980902	18-5309-1	983871	18-7201	986629	18-2783
912477	18-0430	980959	18-1904	983877	18-1172	986642	18-5108
912509	18-15435	981078	18-5911	983878	18-1171	986643	18-5361
912614	18-3502	981080	18-5312-1	983880	18-2338	986651	18-5406
912714	18-15520	981195	18-2071	983891	18-1161	986658	18-0647
912766	18-3878	981196	18-2072	983892	18-1170	986779	18-3593
912768	18-0464	981268	18-2073	983895	18-3058	986782	18-7236
912793	18-75125	981288	18-5908	983902	18-21751	986783	18-7235
912954	18-0468	981289	18-5907	983937	18-2100	986784	18-7237
912955	18-0405	981359	18-7615-1	983967	18-4750	986796	18-7238
912965	18-2845	981428	18-7615-1	983973	18-2765	986799	18-7237
912978	18-4408	981564	18-7615-1	984012	18-1602	986800	18-7239
912979	18-1238	981566	18-7229	984054	18-1901	986804	18-7241
912981	18-0347	981650	18-7268	984180	18-7609-1	986865	18-7229
912988	18-0887	981705	18-7615-1	984264	18-6399	987136	18-5303
912989	18-1213	981797	18-2663	984290	18-21752-1	987251	18-2791
913270	18-0664	981799	18-2666	984356	18-6814	987313	18-7242
913275	18-0887	981801	18-2669	984360	18-3593	987315	18-7243
913276	18-2815	981803	18-7615-1	984398	18-5353	987317	18-7244
913277	18-0347	981821	18-5903	984401	18-5352	987319	18-7245
913393	18-0401	981911	18-7861	984456	18-5910	987438	18-7246
913488	18-75100	982019	18-6950	984458	18-2672	987440	18-7246
913745	18-0528	982058	18-6755	984459	18-2673	987447	18-3577-2
913758	18-0352	982063	18-7267	984461	18-3212-1	987467	18-2765
913783	18-0943-2	982069	18-6764	984461	18-3348	987485	18-7246
913783	18-0943-2-9	982073	18-6764	984487	18-7086	987603	18-2673
913784	18-1909-1	982121	18-5911	984491	18-7854	987661	18-2245-1
914036	18-2764	982132	18-2595	984513	18-6028	987678	18-2246
914323	18-0518	982195	18-5908	984513	18-6028A	987738	18-5888
914445	18-4024	982202	18-5907	984513	18-6102	987739	18-5889
914488	18-8369	982209	18-5376	984536	18-6270	987740	18-5890
914555	18-3937	982211	18-5404-1	984536	18-6276	987774	18-6261
914556	18-3939	982217	18-7608-1	984537	18-21754	987784	18-1922
914557	18-3938	982219	18-7609-1	984547	18-6103	987811	18-5920
914716	18-2383	982223	18-7608-1	984547	18-6103A	987894	18-5303
914723	18-0652	982223	18-7615-1	984628	18-5917	987895	18-5347
914736	18-0655	982230	18-7862	984629	18-21755	987925	18-5258
		982240	18-7278	984744	18-3206	987926	18-5260

O.E. #	SIERRA #	O.E. #	SIERRA #	O.E. #	SIERRA #	O.E. #	SIERRA #
OMC cont.		3853818	18-6028	5000309	18-8383	R077002	18-7824-2
987986	18-5413	3853818	18-6028A	5000356	18-4801	R084003	18-7697
988013	18-6270	3853818	18-6102	5000363	18-1703	R094020A	18-2702-1
988013	18-6276	3853827	18-1230	5000581	18-6528	R096116	18-4220
988037	18-7330	3853847	18-1401	5001036	18-3546	R096117	18-3200
988162	18-0410	3853850	18-3599-2	5001344	18-5768	R103001	18-5404-1
988217	18-5919	3853862	18-21753	5001593	18-3059	R103003	18-5407
988247	18-6841	3853912	18-0410	5001594	18-3390	R103004	18-5403
989966	18-2218	3853913	18-0410	5001594	18-3392	R103011	18-5245
1984462	18-5717	3853917	18-21752-1	5001595	18-3315-2	R108001	18-5376
3850216	18-5811	3853945	18-6779	5004257	18-1703	R114001	18-5314
3850357	18-7677	3853960	18-3937	5004705	18-4148-1	R114002	18-5303
3850379	18-1238	3853962	18-21751	5005113	18-6802	R114004	18-5314
3850396	18-7684	3854001	18-5108	5005114	18-6801	R115001	18-5338
3850426	18-1074	3854002	18-5443	5005115	18-6803	R115002	18-5345
3850456	18-1909-1	3854003	18-5107-1	5005254	18-6281	R117001	18-5433
3850495	18-2875-1	3854017	18-3593	5005266	18-7722	R117012	18-7648
3850495	18-2875-1-9	3854033	18-1402	5005440	18-3543	R119001	18-5450
3850496	18-0943-2	3854072	18-30585	5006319	18-6744	R130001	18-5801
3850595	18-0893	3854095	18-1231	5006373	18-8384	R130012	18-15214
3850597	18-2791	3854118	18-3577-2	5006511	18-3453	R142006	18-2434
3850799	18-1922	3854127	18-2765	5007556	18-3476	RA057004	18-3584-1
3850809	18-7326	3854158	18-7601	5007662	18-6803	RA057018	18-3599-2
3850810	18-7331	3854182	18-6261	5007972	18-3472	RA057019	18-3577-2
3850812	18-2174	3854190	18-5920	5008968	18-8905	RA057023	18-3586-1
3850813	18-2128	3854194	18-6291	5008972	18-4537	RA057024	18-3587-1
3850814	18-2337	3854217	18-5248	5030087	18-3735	RA057036	18-42608
3850815	18-2146	3854252	18-3939	5030699	18-3499	RA097002	18-5957
3852109	18-0874	3854269	18-0868	5030973	18-74108	RA097003	18-5957
3852111	18-0398	3854280	18-7330	5031411	18-7915-1	RA097006	18-5957
3852113	18-0876	3854286	18-3060	5031417	18-8904	RA097007B	18-5984
3852215	18-5894	3854299	18-3879	5031456	18-8337	RA097007B	18-6288
3852338	18-1848	3854311	18-5408	5032238	18-7719	RA097007C	18-6453
3852350	18-4194	3854331	18-5362	5032323	18-7716	RA097009	18-6452
3852374	18-1986-1	3854406	18-0410	5032424	18-7773	RA107001	18-5309-1
3852384	18-2339	3854512	18-7703	5033102	18-7903	RA108002	18-5369
3852455	18-0183-1	3854539	18-2454	5033112	18-3099	RA108003	18-5352
3852477	18-0891	3854548	18-5354	5033372	18-3497	RA108009	18-5244
3852531	18-7407	3854549	18-5405	5033539	18-7896	RA122001	18-5903
3852548	18-8349	3854620	18-7326	5033542	18-8907	RA122001	18-5920
3852560	18-2996	3854661	18-3469	5033919	18-7897	RA122008	18-5907
3852563	18-1713	3854751	18-5913-1	5035703	18-7895	RA122009	18-5603-1
3852565	18-7153	3854809	18-6261	5035974	18-7953	RA122009	18-5908
3852568	18-4749-9	3854905	18-7679	5036216	18-3498	RA122019	18-6443
3852648	18-3730	3854942	18-0311	5031417	18-3096	RK122014	18-5920
3852654	18-0468	3854956	18-0518	173232, 502902	18-7824-2	RM0002	18-0677-1
3852655	18-0405	3855104	18-7792	173232, 502902	18-7824-2	RM0003	18-0878
3852656	18-0322	3855182	18-7689	584605, 586275	18-6863	RM0007	18-0183-1
3852657	18-0519	3855270	18-1909-1	85R-4541	18-7096	RM0017	18-0898
3852687	18-0664	3855412	18-6028	OMC / BOMBARDIER			
3852691	18-0887	3855412	18-6028A	336226	18-0694	RM0032	18-3883
3852692	18-2815	3855412	18-6102	336227	18-0693	RM0099	18-0676-1
3852693	18-0347	3855958	18-7330	336388	18-0696	RN0067	18-7227
3852696	18-2779	3856127	18-1400	336389	18-0695	RN0116	18-7081
3852741	18-2780-1	3856138	18-1237	339601	18-0692	RN0116-2	18-7081
3852742	18-2781	3856444	18-1909-1	340919	18-0492	RN0118	18-7096
3852824	18-0147	3856600	18-6261	346007	18-0491	RN0118-1	18-7017
3853132	18-0518	3857561	18-6261	347205	18-0690	RN0120	18-7096
3853226	18-4024	3857650	18-7330	437155	18-4406	RN0120-1	18-7017
3853256	18-0680	3857656	18-1848	437725	18-4428	RO20001	18-5899
3853268	18-3937	3857723	18-1986-1	437779	18-4420	RO28001	18-1996
3853336	18-2946	3857944	18-1909-1	439202	18-4420	RO29001	18-1899
3853340	18-4161	3857985	18-7331	5000400	18-4421	RO85035	18-2103
3853341	18-1213	3857986	18-7326	PERKINS			
3853342	18-0327	3858261	18-7326	2654403	18-7886	RO96081	18-4214
3853361	18-0903	3858340	18-3593	185086600	18-6944	RP026002E	18-3671
3853380	18-3876	3858437	18-21752-1	2871A651	18-5975	RP061015	18-3060
3853477	18-4160	3858714	18-7331	PLEASURECRAFT			
3853510	18-1232	3860095	18-1233	3705042	18-0889	RP061017	18-3061
3853511	18-3874	3860171	18-6261	9-37824	18-7976	RP080026	18-8127
3853512	18-0468	3911020	18-4173	R017066	18-3700	POLARIS	
3853528	18-1234	3911023	18-4164	R020027	18-7677	3240120	18-15080
3853655	18-2068	3921473	18-0466	R020035A	18-7646	PS-4	72-5104-2
3853732	18-3883	3923440	18-0466	R026002E	18-3551	PS-4	72-5104-3
3853742	18-0183-1	3930912	18-0346	R047111	18-7480	PS-4	72-5104-7
3853796	18-3584-1	3931593	18-0348	R077001	18-7875	VES	72-5103-2
3853799	18-3558	3935449	18-0980	OMC / BOMBARDIER			
		5000074	18-1702	336226	18-0694	VES	72-5103-3
				336227	18-0693	VES	72-5103-4
				336388	18-0696	VES	72-5103-5
				336389	18-0695	VES	72-5103-7
				339601	18-0692	VES	
				340919	18-0492	VES	
				346007	18-0491	VES	
				347205	18-0690	VES	
				437155	18-4406	VES	
				437725	18-4428	VES	
				437779	18-4420	VES	
				439202	18-4420	VES	
				5000400	18-4421	VES	
				PERKINS			
				2654403	18-7886	VES	
				185086600	18-6944	VES	
				2871A651	18-5975	VES	
				PLEASURECRAFT			
				3705042	18-0889	VES	
				9-37824	18-7976	VES	
				R017066	18-3700	VES	
				R020027	18-7677	VES	
				R020035A	18-7646	VES	
				R026002E	18-3551	VES	
				R047111	18-7480	VES	
				R077001	18-7875	VES	

O.E. #	SIERRA #	O.E. #	SIERRA #	O.E. #	SIERRA #	O.E. #	SIERRA #
POWER POLE		17059289	18-7618-1	09284-08003	18-0569	16510-82703	18-7897
PUMP PRO-F	18-6819	17059290	18-7616-1	09289-10002	18-0545	16510-87J00	18-7915-1
PUMP SPN-F	18-6818	17059291	18-7605-1	09289-22007	18-8345	16510-93J00	18-7895
PRESTOLITE		17059292	18-7605-1	09381-14001	18-42940-9	16510-96J00	18-7905-1
873051	18-6881	17059298	18-7619-1	09381-18002	18-42950-9	17400-87D11	18-3253
110-258	18-6955	17068453	18-7855	09381-20003	18-42960-9	17400-87E03	18-3254
110-258A	18-6955	17078904	18-7854	09420-03005	18-3292	17400-87E04	18-3254
15-79	18-5840	17080560	18-7616-1	09420-04009	18-3404	17400-90J11	18-3258
ETK	4001	17080561	18-7615-1	09420-05005	18-3296	17400-90J20	18-3258
ETK	4101	17080561	18-7618-1	09420-05006	18-3291	17400-92D01	18-3255
ETK	4102	17080562	18-7618-1	09420-05009	18-3291	17400-93951	18-3256
EVD	4001	17080564	18-7605-1	11141-87D60	18-3825	17400-93J00	18-3264
EVD	4002	17080565	18-7605-1	11141-87D90	18-3825	17400-93J02	18-3264
HYK4001	18-6274	17081060	18-7610-1	11141-87E10	18-3822	17400-94611	18-3257
SAW4201	18-5840	17081299	18-7619-1	11141-87E90	18-3822	17400-94700	18-3243
SAW4206	18-5807	17082403	18-7607-1	11141-93901	18-3808	17400-94701	18-3243
SAW4207	18-5840	17083522	18-7619-1	11141-93960	18-3808	17400-95350	18-3244
SAW4210	18-5840	17085013	18-7615-1	11141-94401	18-3810	17400-95351	18-3244
VSH-6201	AFY	SEA-DOO		11141-94450	18-3810	17400-95550	18-3244
VSH-6201JY	18-5710	278-000-123	18-6878	11141-94506	18-3823	17400-96350	18-3242
RACOR		278-000-186	18-6868	11141-94600	18-3824	17400-96351	18-3242
2010PM-OR	18-99183	278-000-311	18-6868	11141-94620	18-3823	17400-96353	18-3242
2010SM-OR	18-99186	278-000-316	18-6868	11141-94620	18-3824	17400-98551	18-3259
2010TM-OR	18-99182	278-000-484	18-6867	11141-94701	18-3820	17400-98652	18-3260
2020N-02	18-99187	278-000-485	18-6867	11141-94702	18-3820	17400-98661	18-3266
2020N-10	18-99181	278-000-576	18-6866	11141-94720	18-3820	17400-98J00	18-3267
2020N-30	18-99180	278-000-577	18-6866	11141-95305	18-3813	17400-98J01	18-3267
2040N-02	18-99191	278-001-038	18-6866	11141-95320	18-3813	17411-93901	18-3480
2040N-10	18-99185	278-001-239	18-6879	11141-95505	18-3814	17411-94421	18-3481
2040N-30	18-99184	278-001-292	18-6871	11141-95512	18-3814	17461-87E11	18-3049
6H3-W0001-02	18-99176	278-001-300	18-6867	11141-95D10	18-3819	17461-87E12	18-3049
B32013	18-7928-1	278-001-301	18-6866	11141-95D90	18-3819	17461-90J00	18-3023
B32020MAM	18-7929	278-001-376	18-6859	11141-96303	18-3809	17461-90J01	18-3023
R12P	18-99199	278-001-497	18-6869	11141-96344	18-3809	17461-92D02	18-3000
R12S	18-99194	278-001-554	18-6876	11141-98101	18-3807	17461-93001	18-3092
R12T	18-99193	278-001-581	18-6874	11141-98130	18-3807	17461-93003	18-3092
R20P	18-99200	278-001-802	18-6859	11141-98401	18-3806	17461-93004	18-3092
R20S	18-99196	278-001-935	18-6867	11141-98411	18-3806	17461-93901	18-3099
RK10012	18-7394	278-001-936	18-6869	11141-98504	18-3816	17461-93902	18-3099
RK10215	18-99201	278-002-199	18-1294	11141-98510	18-3816	17461-93903	18-3099
RK10222	18-7987	290-888-993	18-6905	11141-98522	18-3816	17461-93J00	18-3035
RK22244	18-0179	290-888-999	18-6905	12110-93120	18-40140	17461-94500	18-3023
RK22368	18-99203	420-888-9933	18-6905	12110-94400	18-40110	17461-94501	18-3023
RK22628	18-9884	420-888-994	18-6905	12140-93121	18-39480	17461-94502	18-3023
S3213	18-7919	420-888-996	18-6905	12140-94400	18-39540	17461-94503	18-3023
S3214	18-7920	SHERWOOD PUMP		12151-92502	18-42870	17461-94504	18-3023
S3227	18-7948	9959	18-3060	12151-93100	18-42860	17461-94505	18-3023
S3232	18-7949	10615	18-3061	12151-94400	18-42850	17461-94506	18-3023
S3240	18-7947	10927	18-3168	12161-91L00	18-1758	17461-94510	18-3023
ROCHESTER		10931	18-3140	12161-92L00	18-1759	17461-94511	18-3023
1708563	18-7616-1	12322	18-3169	12161-93902	18-1757K	17461-94520	18-3023
7036543	18-7609-1	12859	18-3169	12161-93902	18-1757K	17461-94700	18-3094
7040080	18-7608-1	18200	18-3077	12161-94400	18-1759	17461-94701	18-3094
7040082	18-7609-1	10615K	18-3047	12161-94400	18-1759K	17461-94701	18-3094
7040083	18-7608-1	9959K	18-3046	12161-94400	18-1759K	17461-95300	18-3095
7040089	18-7608-1	9979K	18-3079	12161-96300	18-1758	17461-95301	18-3095
7041369	18-7609-1	SKI-DOO		12410-96351-050	18-39530	17461-95302	18-3095
7042183	18-7608-1	XPS 779126	72-5103-2	13119-91J00	18-0792	17461-96301	18-3096
7043182	18-7609-1	XPS 779127	72-5103-3	13910-87D00	18-7752	17461-96311	18-3096
7043183	18-7608-1	SUZUKI		13910-89J01	18-7773	17461-96312	18-3096
7043184	18-7608-1	09141-14008	18-3710	13910-94400	18-7753	17461-98501	18-3097
7044182	18-7609-1	09141-18005	18-3726	13910-94701	18-7754	17461-98502	18-3097
7044185	18-7603-1	09168-10022	18-8331	13910-95D00	18-7755	17461-98503	18-3097
7044291	18-7618-1	09204-02004	18-3737	15170-91J00	18-3497	17461-98503	18-3097
17057283	18-7605-1	09204-03003	18-3735	15170-93911	18-3495	17461-985M0	18-3097
17057285	18-7605-1	09204-03004	18-3735	15170-94320	18-3496	17462-93990	18-3292
17057287	18-7616-1	09263-14022	18-1414	15170-94J00	18-3498	17471-87D01	18-3189
17057298	18-7615-1	09263-18016	18-1415	15170-94J0V	18-3498	17471-87E01	18-3192
17059052	18-7608-1	09263-20051	18-1412	15170-99E00	18-3498	17471-92D10	18-3193
17059054	18-7609-1	09263-20072	18-1417	15170-99E00	18-3499	17471-92J00	18-3192
17059057	18-7608-1	09263-27005	18-1416	15200-96J00	18-7348	17471-93902	18-3190
17059280	18-7615-1	09280-08008	18-7118	15410-87J10	18-7716	17471-94501	18-3191
17059280	18-7617-1	09280-75002	18-7140	15410-87J30	18-7953	17471-98503	18-3188
17059283	18-7619-1	09282-24004	18-0544	15410-94400	18-7735	17472-91J00	18-0761
17059287	18-7616-1	09282-30007	18-0546	15410-96J00	18-7711	17472-92D10	18-0479
17059288	18-7615-1	09283-10011	18-0551	15410-98500	18-7719	17472-93911	18-0478
				15412-93J00	18-7936	17472-93J00	18-0778
				16510-05240	18-7903	17472-95200	18-0459
				16510-45H10	18-8870	17472-95310	18-0460
				16510-61A20-MHL	18-7896	17472-96301	18-0461

O.E. #	SIERRA #	O.E. #	SIERRA #	O.E. #	SIERRA #	O.E. #	SIERRA #
SUZUKI cont.		65750-94404	18-80418	430020	18-2994	835304	18-5314
17472-98503	18-0477-9	65750-95500	18-8079	430039	18-2924	835308	18-5338
17472-98611	18-0480	65750-95510	18-8079	430143	18-7878-1	835390	18-3599-2
17472-98J00	18-0651	65750-98505	18-8062	430172	18-2526	835417	18-0398
17582-93J00	18-0793	990C0-10W40-1GL	18-9551-3	461092	18-2925	835440	18-7824-2
17685-87D10	18-0797	990C0-10W40-1QT	18-9551-2	461511	18-1479	835512	18-3060
17685-97J00	18-0794	99105-00192	18-8071	462623	18-2966	835576	18-7859
17685-98J00	18-0795	99105-00193	18-8078	463377	18-4029	835702	18-5369
17685-99E00	18-0796	99105-20004-BWL	18-7922-1	463505	18-7890	835704	18-5345
18213-98J00	18-32154	99105-20005	18-7948	463587	18-2926	835705	18-5303
25223-94400	18-8334	99105-20006	18-7947	463902	18-4245	835804	18-1931-1
25700-87D00	18-8335	99105-20006-BWL	18-7987	463999	18-2927	835874	18-3047
25700-90J01	18-8373	TOHATSU		466634	18-7880	835874	18-3061
25700-92J00	18-8374	369060210M	18-5143	466987	18-7942	835966	18-2949
25700-93J00	18-8380	3A0060401M	18-5133	477024	18-4200	835998	18-5433
25700-94400	18-8337	3A0060481M	18-5133	477556	18-0034	837924	18-6872
25700-94500	18-8338	3G2060602M	18-5134	502036	18-1402	838513	18-70704
25700-94700	18-8339	UNIVERSAL		803762	18-1727	838637	18-4466
25700-95500	18-8340	288182	18-6263	804190	18-0184	838638	18-4471
25700-95D00	18-8341	288759	18-6263	804261	18-4259	838928	18-6021
25700-95J00	18-8385	299381	18-7884	804695	18-2039	838929	18-6001
25700-98J00	18-8386	301068	18-6140	806256	18-3106	839423	18-4208
25700-99E00	18-8381	301069	18-6141	807036	18-4216	839430	18-6790
31100-89J00	18-6419	VALEO		808007	18-3274	839534	18-4209
31100-90J00	18-6831	541663	18-5943	812994	18-4150	840808	18-5906
31100-92E00	18-6417	2541451	18-5939	813967	18-8368	841070	18-5352
31100-93J00	18-6941	2937430	18-5976	814301	18-2153	841161	18-7286
31100-94600	18-6827	2939590	18-5975	814356	18-2939	841162	18-7862
31100-94601	18-6827	A0002655299	18-6848	818525	18-5419	841177	18-6268
31100-94610	18-6416	A13N147M	18-5959	820545	18-6822	841207	18-3876
31100-94610	18-6827	A13N148M	18-5959	820652	18-59710	841243	18-5411
31100-94702	18-6429	A13N1M	18-5959	822454	18-59710	841244	18-5375
31100-95313	18-6428	A13N234	18-5939	824633	18-2928	841262	18-5349
31100-95600	18-6414	A13N259	18-5943	824677	18-2989	841263	18-5358
31100-95J00	18-6945	A13N2M	18-5959	824803	18-7099	841292	18-7000
31100-95J01	18-6945	VOLVO		826341	18-4204	841380	18-59700
31100-96J00	18-6941	35254	18-5436	826423	18-75125	841640	18-3586-1
31100-96J01	18-6941	72021	18-6846	826493	18-7281	841750	18-7879-1
31173-95310	18-56008	82745	18-4218	826495	18-5959	841762	18-5959
31173-99E00	18-56009	125017	18-7178	826648	18-7888	841762	18-59700
32140-93900	18-5152	174448	18-9098	827247	18-2045	841763	18-59700
32900-93911	18-5144	181620	18-2057	827303	18-59710	841765	18-5959
33410-92L10	18-5151	192212	18-4201	829207	18-15460	841765	18-59700
33410-94400	18-5151	233991	18-6872	829592	18-4219	841766	18-5959
37100-87J00-OEP	18-18304	240149	18-5306	829620	18-4464	841766	18-59700
37110-99-E00	MP51010	240501	18-6872	829714	18-2934	841821	18-15430
37110-99-E00	MP51012	241669	18-5393	829913	18-8124	841907	18-5403
38100-87000-OIT	18-6785	241812	18-6271	831009	18-3106	841926	18-5353
38100-87D10-OED	18-6786-1	243460	18-5305	831617	18-2527	841994	18-7086
38100-87D10-OIT	18-6786-1	243632	18-5357	831622	18-2519	842775	18-6872
38100-87D10-35J	18-6786-1	243653	18-5342	831891	18-2528	843511	18-6872
38100-87E10-OED	18-6785	243658	18-5394	831892	18-2529	843563	18-28050
38100-87E20-OED	18-6785	243797	18-5356	832570	18-4206	845792	18-75125
38100-87JOEP	18-18304	243799	18-5305	832598	18-6000A	845940	18-6846
38100-87J11	18-6793	243801	18-5319	832598	18-6104	847651	18-59710
38100-87J20	18-6793	243903	18-5428	832669	18-2990	849561	18-59710
38100-92E00-OED	18-6786-1	273663	18-7783	832675	18-2199	849602	18-59710
38100-92J02	18-18303	324825	18-8204	832820	18-4205	850046	18-6791
38100-92J10	18-18303	328516	18-3938	832831	18-2776	850785	18-4210
38100-93J01	18-18303	329653	18-8203	832846	18-2778	850834	18-6758
38100-93J02	18-18303	370409	18-3944	832965	18-4234	850888	18-4211
38100-96J00	18-18303	416033	18-2933	833188	18-4463	850889	18-4212
38860-76F01	18-5731	418265	18-2974	833274	18-3842	851120	18-6951
55125-87D00	18-6033	418411	18-2935	833453	18-3834	851261	18-4213
55125-96310	18-6098	418412	18-2937	833950	18-4005	851407	18-0558
55320-95310	18-6032	418445	18-2936	833995	18-3076	852520	18-6791
56132-95J00	18-0650	418870	18-2922	833996	18-2044	852835	18-6004
57630-92E00	18-3775	419310	18-2965	834337	18-7884	852835	18-6004A
57630-94300	18-3777	419652	18-4474	834476	18-2531	852835	18-6105
57630-94500	18-3774	419653	18-4473	834520	18-5806	852928	18-6274
57630-96300	18-3778	419678	18-2923	834548	18-4044	852928	18-6838
65720-94401	18-80409	419734	18-4468	834560	18-5348	852928	18-6881
65720-94411	18-8087	419735	18-4470	834609	18-5959	852928	18-6822
65720-986B0	18-80425	423135	18-7926	834751	18-2766	853012	18-710-64-2
65740-95500	18-8078	430017	18-2518	834893	18-5911	853255	18-2104
65750-87J10	18-80419	430018	18-2525	834963	18-5959	853548	18-7306
65750-87J11	18-80419			834975	18-5425	853670	18-2040

O.E. #	SIERRA #	O.E. #	SIERRA #	O.E. #	SIERRA #	O.E. #	SIERRA #
	VOLVO cont.	875407	18-7085	908611	18-2946	3854003	18-5107-1
853868	18-25251	875422	18-2596	912213	18-2128	3854017	18-3593
854031	18-2777	875550	18-2793	912227	18-3879	3854018	18-36905
854045	18-4210	875569	18-2982	912957	18-0519	3854020	18-7238
854047	18-4213	875571	18-8813-1	912979	18-1238	3854026	18-7229
854329	18-6792	875574	18-3205	914323	18-0518	3854033	18-1402
854346	18-6770	875575	18-3075	914445	18-4024	3854095	18-1231
855326	18-5911	875580	18-3666	914556	18-3939	3854105	18-7242
855383	18-2991-1	875583	18-3076	914557	18-3938	3854106	18-7244
855383	18-2991-1-9	875584	18-3208	914816	18-4161	3854107	18-7245
855387	18-1930-2	875660	18-3037	914930	18-3879	3854116	18-7246
855507	18-6456	875660	18-3078	915236	18-4160	3854127	18-2765
855798	18-5657	875698	18-3263	925054	18-7179	3854130	18-6125Z
855845	18-5403	875736	18-3037	925055	18-7180	3854158	18-7601
855889	18-7072	875736	18-3078	925065	18-7190	3854161	18-7492
855967	18-2991-1	875741	18-8357	925091	18-7181	3854164	18-69550
855967	18-2991-1-9	875759	18-3262	925092	18-7182	3854190	18-5920
856028	18-2929	875769	18-3261	925093	18-7183	3854202	18-3869
856034	18-2949	875779	18-3654	925095	18-7122	3854215	18-29322
856037	18-2995	875781	18-3656	925256	18-7184	3854217	18-29322
856044	18-2928	875784	18-3658	925259	18-7186	3854217	18-5248
856116	18-2909	875785	18-3659	925261	18-7187	3854218	18-5413
856306	18-70704	875787	18-3660	941816	18-4215	3854252	18-3939
856364	18-3599-2	875791	18-3663	941907	18-4236	3854261	18-5406
856470	18-7099	875794	18-3662	943218	18-4238	3854269	18-0868
856471	18-7000	875795	18-3664	943414	18-2367	3854280	18-7330
856472	18-7000	875796	18-3665	946242	18-2046	3854286	18-3046
856474	18-3876	875805	18-6005	949656	18-7154	3854286	18-3060
856609	18-3577-2	875808	18-3080	950813	18-15410	3854299	18-3879
856883	18-1931-1	875815	18-6009	950818	18-15460	3854311	18-5408
856891	18-1935-1	875815	18-6009A	951924	18-4241	3854331	18-5362
856894	18-1932	875821	18-6010	952141	18-15500	3854406	18-0410
857037	18-1936	875821	18-6010A	955974	18-7193	3854512	18-7703
858201	18-7858	875821	18-6106	955983	18-7188	3854527	18-7702
858459	18-35444	875822	18-2775	955989	18-7149	3854539	18-2454
858467	18-3175	875826	18-2744	955995	18-7192	3854548	18-5354
858488	18-7907	875827	18-2755	956000	18-7194	3854549	18-5405
859155	18-3843	875828	18-2757	958303	18-15325	3854620	18-7326
859428	18-35442	875847	18-2774	958310	18-15390	3854751	18-5913-1
859647	18-3867	875848	18-2758	958311	18-15405	3854905	18-7679
861250	18-0307	876037	18-5704	958314	18-15435	3854942	18-0311
861251	18-0310	876038	18-6271	958320	18-15495	3854956	18-0518
861476	18-8701	876039	18-5705	958357	18-15415	3855017	18-7241
861477	18-8126	876040	18-6266	958498	18-4046	3855104	18-7792
862293	18-7888	876069	18-57702	958838	18-2043	3855182	18-7689
870670	18-6271	876097	18-3656	958860	18-2047	3855194	18-7704
870690	18-5357	876120	18-3287	966382	18-15435	3855275	18-2598
870998	18-6958	876185	18-7890	966857	18-4046	3855276	18-7268
872022	18-6846	876267	18-8358	975672	18-7181	3855296	18-7757
872066	18-7647	876268	18-8359	984513	18-6028	3855411	18-6028
872235	18-5939	876278	18-4204	985316	18-1401	3855412	18-6102
872241	18-5906	876279	18-2366	985727	18-21753	3855610	18-6125M
872272	18-6268	876294	18-2744	986280	18-6779	3855958	18-7330
872300	18-6266	876300	18-2998	988037	18-7330	3855991	18-3577-2
872449	18-6838	876302	18-2813	1141679	18-9680-2	3856003	18-5919
872449	18-6881	876303	18-3870	1141681	18-9680-5	3856004	18-5913-1
872757	18-6846	876305	18-3662	1141682	18-9680-7	3856127	18-1400
872793	18-6124Z	876306	18-2814	1218630	18-4472	3856138	18-1237
872926	18-5943	876314	18-0252	1218674	18-1478	3856393	18-7641
873051	18-6838	876342	18-2983	1243632	18-5357	3856884	18-33800
873178	18-6004	876356	18-2980	1266286	18-7878-1	3856961	18-3677
873178	18-6004A	876358	18-2982	1266796	18-2930	3857265	18-6274
873178	18-6105	876359	18-2817	1306169	18-5305	3857487	18-7700
873179	18-6000	876376	18-4342	1306630	18-4031	3857489	18-6806
873179	18-6000A	876380	18-4341	1317466	18-2933	3857532	18-5899
873179	18-6104	876384	18-0489	1336255	18-2530	3857561	18-6261
873228	18-2432	876433	18-2818	1357199	18-6839	3857650	18-7330
873229	18-2433	876631	18-2758	1378645	18-2968	3857656	18-1848
873395	18-6123Z	876633	18-2757	1378646	18-2970	3857723	18-1986-1
873635	18-6846	877066	18-3275	1378864	18-2926	3857747	18-6275
873757	18-6846	877349	18-3658	1378870	18-2972	3857813	18-6265
873770	18-5939	881681	18-6872	1378879	18-2930	3857985	18-7331
873771	18-6846	881682	18-6958	3853945	18-6779	3857986	18-7326
875192	18-2625	897367	18-4214	3853960	18-3937	3858061	18-9410-7
875383	18-3209	897426	18-2041	3853982	18-5913-1	3858071	18-6817
875400	18-2983	897707	18-2104	3853983	18-3676	3858081	18-5700
875401	18-2980	897720	18-6792	3854001	18-5108	3858256	18-3081
		897873	18-4239	3854002	18-5443	3858261	18-7326

O.E. #	SIERRA #	O.E. #	SIERRA #	O.E. #	SIERRA #	O.E. #	SIERRA #
VOLVO cont.		1357199-7	18-6839	60X-44323-00-00	18-3520	62Y-41133-00	18-99002
3858340	18-3593	17253-6	18-3745	60X-81800-00-00	18-6832	62Y-41134-01	18-99003
3858462	18-15450	3523301-4	18-6839	60X-W0078-00	18-3522-1	62Y-43800-11-00	18-6811
3858714	18-7331	3803227-2	18-59700	60X-W0078-00-00	18-3516	62Y-43880-00-00	18-6811
3858809	18-5700	3803270-2	18-6846	61A-11181-A0-00	18-3891	62Y-46241-00-00	18-15144
3858941	18-7685	3851218-2	18-7789	61A-11181-A1-00	18-3891	62Y-W0001-20-00	18-74540
3858979	18-7706	3851218-2	18-7989	61A-11193-A1	18-99051	63D-11181-A1	18-99060
3859054	18-5811	3852374-2	18-1986-1	61A-11381-A0	18-99052	63D-11193-A0	18-99059
3859078	18-7493	3852648-9	18-3730	61A-12414-A0-00	18-0829	63D-44312-00	18-9083
3859082	18-7643	3853862-5	18-21753	61A-13411-00	18-79976	63D-44316-00-00	18-0483
3860082	18-5979	3853962-3	18-21751	61A-13621-A0	18-99053	63D-44322-00-00	18-3449
3860566	18-6275	3854194-2	18-6291	61A-13645-00	18-99054	63D-44323-00-00	18-3186
3860764	18-5913-1	3855270-9	18-1909-1	61A-13646-00	18-99055	63D-45114-A0	18-99004
3860769	18-5957	3855270-9	18-1909-1	61A-24563-00-00	18-7782	63D-45123-00	18-99005
3860879	18-6806	3856600-6	18-6261	61A-24564-00-00	18-7486	63D-W0001-00	18-99061
3861267	18-7648	3857846-4	18-2434	61A-41134-A0	18-99000	63D-W0078-01-00	18-3415
3861575	18-6804	3858437-1	18-21752-1	61A-43880-01-00	18-6782	63D-W0078-01-00	18-3434
3862014	18-5405	419763-8	18-2965	61A-43880-02-00	18-6782	63M-81800-00-00	18-6908
3862228	18-7989	463903-5	18-4246	61A-44311-00-00	18-3173-1	63M-81960-00-00	18-6857
3862281	18-3081	5003564-1	18-6839	61A-44311-01	18-3522-1	63P-12414-00-00	18-99127
3862281	18-3277	576266-8	18-8361	61A-44311-01	18-3523-1	63P-13915-00-00	18-79902
3862500	18-7513	818701-5	18-5310	61A-44311-01-00	18-3173-1	63P-14984-00	18-0712
3862567	18-3276-1	834438-4	18-1930-2	61A-44322-00-00	18-3333	63P-45987-00-00	18-73918
3862612	18-6848	834625-6	18-59700	61A-44322-02-00	18-3519	63P-46241-00-00	18-15140
3862613	18-6845	834985-4	18-7095	61A-45113-A0	18-99056	63P-81950-00	18-1522
3862613	18-6847	835908-5	18-2971-1	61A-45114-A0	18-99001	63V-11181-A2	18-99140
3862665	18-6845	841047-4	18-7641	61A-45371-00-00	18-6119A	63V-14301-00-00	18-34603
3863061	18-1909-1	841066-4	18-5903	61A-45371-00-00	18-6119Z	63V-14985-00	18-7064
3863061	18-1909-1	841293-4	18-7001	61A-45527-00-00	18-9076	63V-15713-00-00	18-51001
3863085	18-25250	841313-0	18-7641	61A-45527-00-00 +	18-9079	63V-24411-00-00	18-7390
3863130	18-7642	841378-3	18-59700	61A-45538-00-00	18-9075	63V-41133-A1	18-99006
3863193	18-6028A	841634-9	18-7200	61A-45538-00-00 +	18-9079	63V-44301-00	18-3412
3863450	18-2780-1	841836-0	18-7000	61A-81800-01-00	18-6861	63V-44301-00-00	18-3356
3863450	18-2780-1	847306-8	18-6872	61A-81840-00-00	18-56007	63V-44322-00-00	18-3444
3884950	18-5882	847308-4	18-6958	61A-81941-00-00	18-5853	63V-44323-00-00	18-3195
3884950	18-6845	849748-9	18-6955	61A-81950-01	18-1523	63V-44328-01	18-9090
3885317	18-5913-1	854525-3	18-6817	61A-W0001-01-00	18-4400	63V-44352-01-00	18-3040
3888813	18-6127A	855384-4	18-1935-1	61A-W0001-21-00	18-2799	63V-44365-10-00	18-3505
3888814	18-6127Z	855846-2	18-5303	61A-W0001-A1-00	18-4400	63V-45113-A1	18-99150
3888815	18-6127M	856039-3	18-2971-1	61A-W0001-C1-00	18-2799	63V-45315-A0	18-99063
3888816	18-6126A	873757-9	18-6846	61A-W0078-01-00	18-3395	63V-85520-00	18-5183
3888817	18-6126Z	875807-0	18-3079	61A-W0078-A2-00	18-3396-1	63V-85520-01	18-5183
3888818	18-6126M	875808-8	18-3036	61A-W0078-A3-00	18-3396-1	63V-85533-00-00	18-25604
3888821	18-2583	875811-2	18-3081	61A-W0093-00-00	18-7772	63V-85540-00-00	18-5132
3888822	18-2584	876532-3	18-8801-1	61A-W0093-01-00	18-7772	63V-85540-01-00	18-5132
3888916	18-1076	877061-2	18-3038	61B-82510-00-00	MP51030	63V-85540-02-00	18-5132
3888917	18-2726	877061-2	18-3077	61B-82510-01-00	MP51030	63V-85570-00-00	18-23602
3911020	18-4173	949658-9	18-7147-9	61B-82510-01-00	MP51032	63V-85580-01-00	18-25652
3911023	18-4164	966694-2	18-4044	61N-11603-00-00	18-3957	63V-W0001-01	18-99175
4785974	18-7926	R7044289	18-80008	61N-11635-00-00	18-4145	63V-W0001-21-00	18-74507
5001677	18-6846	R80316	18-79998	61N-11636-00-00	18-4146	63V-W0078-01	18-3412
5003564	18-6839	WESTERBEKE		61N-14392-00-00	18-7049	63V-W0078-01-00	18-3433
6209190	18-6956	21235	18-7925	61N-24560-10	18-79910	63V-W0093-00-00	18-7058
6643474	18-6271	30220	18-7910-1	61N-24563-00-00	18-7781	646-24251-02-00	18-7713
8602629	18-6953	YAMAHA		61N-44311-00-00	18-3185	646-44322-00-00	18-3328
8602710	18-6953	19-1400-10	18-6843	61N-44311-01-00	18-3185	646-44323-00-00	18-3357
8602714	18-6953	1WD-E3440-00-00	18-8700	61N-44322-01-00	18-3443	646-44352-01-00	18-3072
8676496	18-6953	2MB-E3440-00-00	18-8700	61N-44323-00	18-3194	647-14385-00-00	18-7065
8676498	18-6953	3FV-13440-00-00	18-7902	61N-45251-01-00	18-6120A	647-44366-00	18-1833
8676499	18-6953	3FV-13440-20-00	18-7902	61N-45251-01-00	18-6120Z	647-45616-02	18-3709
8692305	18-8003-1	5GH-13440-00-00	18-7911-1	61N-85570-00-00	18-5113	648-14198-A0-00	18-0775
8757166	18-8802-1	5GH-13440-20	18-8700	61N-85570-10-00	18-5113	648-14385-00-00	18-7066
8757166	18-8823-1	5GH-13440-50-00	18-8700	61N-W0078-11-00	18-3432	648-24411-00-00	18-7839
21124846	18-3557	5JW-13400-00-00	18-8700	61N-W0093-00-00	18-7737	64D-14384-01-00	18-0856-1
21148403	18-3276-1	60E-81800-00-00	18-6921	61T-11193-A1	18-99057	64D-W0093-00-00	18-7756
21213660	18-30778	60E-81950-00-00	18-1525	626-14390-90	18-7079	64E-13645-A0	18-99064
21213664	18-6944	60V-11181-00	18-99048	62L-85570-00-00	18-5129	64E-43822-00-00	18-2081
21323043	18-5467	60V-12411-00	18-3525	62T-85520-00-00	18-5147	64E-4384J-00-00	18-2082
21436799	18-0033	60V-12414-A0-00	18-60508	62T-85520-01-00	18-5147	64E-43869-00-00	18-7469
21707133	18-7514	60V-13621-A0	18-99049	62T-85533-00-00	18-5146	64E-43880-00-00	18-6783
22797780	18-3513	60V-13645-00	18-99050	62X-43880-00-00	18-6811	64E-43880-01-00	18-6783
22844837	18-8702	60V-13907-00-00	18-7343	62X-43880-00-00	18-6812	64J-41133-10	18-99008
30788490	18-9553-2	60V-24251-01-00	18-79907	62X-43880-01-00	18-6812	64X-81800-00-00	18-6862
40005011	18-9553-3	60V-43880-00-00	18-6798	62X-43880-01-00	18-6812	64X-81800-00-00	18-6906
40005012	18-9553-5	60V-46241-00-00	18-15143	62X-43880-09-00	18-6789	650-11651-04-00	18-1755
40005013	18-9553-7	60V-81800-00-00	18-6832	62X-43880-09-00	18-6812	650-11651-04-00	18-1755K
40005014		60X-43315-A0-00	18-0406	62Y-12414-00-00	18-0835	650-24431-00	18-0849
				62Y-14392-00-00	18-7049	650-24431-A0-00	18-0849

O.E. #	SIERRA #	O.E. #	SIERRA #	O.E. #	SIERRA #	O.E. #	SIERRA #
YAMAHA cont.		66M-W0093-01-00	18-7738	67F-W0078-00	18-3409	689-W0001-C1-00	18-2785
655-12414-A1-00	18-0232	66T-11181-A0-00	18-60522	67F-W0078-00-00	18-3451	689-W0001-C2-00	18-0023
65E-85570-00-00	18-5119	66T-11193-A0-00	18-60520	67F-W0093-00-00	18-7743	689-W0078-04-00	18-3426
65L-13645-00	18-99066	66T-14301-00-00	18-34605	67F-W4599-00-00	18-73996	689-W0078-A4-00	18-3426
65L-13646-00	18-99067	66T-15713-00-00	18-51003	67F1439A-00-00	18-7056	689-W0078-A6-00	18-3427
65L-13915-00-00	18-79901	66T-41114-A0-00	18-60532	67H-8592A-00-00	18-7655	689-W0093-02-00	18-7770
65L-14984-00	18-0715	66T-41133-A0-00	18-60529	67H-8592A-01-00	18-7655	68D-11351-A0-00	18-60518
65L-24563-00-00	18-7517	66T-44311-00	18-3413	680-85570-00-00	18-5138	68D-E1169-A0-00	18-60512
65L-24564-00-00	18-7487	66T-44323-00-00	18-3196	680-85570-02-00	18-5138	68D-E1193-A0-00	18-60519
65L-W0001-C0-00	18-74510	66T-45113-A0-00	18-60528	680-85570-09-00	18-5112	68D-E2414-A0-00	18-0754
65N-44315-A0	18-0453	66T-W0078-00	18-3413	682-11351-A0	18-99095	68D-G4311-01-00	18-43263
65N-44323-00	18-0408	66T-W0078-00-00	18-3440	682-11610-01-00	18-3976	68D-G5987-00-00	18-73891
65N-W0078-A0-00	18-4533	66T-W4599-00-00	18-73995	682-11610-11-00	18-3977	68D-WG078-00-00	18-48619
65W-11169-00	18-99068	66V-81960-00-00	18-6651	682-12414-A1-00	18-0836	68F-11181-00	18-99062
65W-11181-30-00	18-63968	670-45997-02-00	18-73914	682-41112-A1	18-99096	68F-11193-01	18-99099
65W-11351-00	18-99069	676-11181-A0-00	18-3892	682-41133-A0	18-99021	68F-11381-00	18-99100
65W-11356-00	18-99070	676-11181-A1-00	18-3892	682-44315-A0-00	18-0768	68F-13440-00	18-79971
65W-13645-00-00	18-60535	676-12414-A0-00	18-60540	682-44352-01-00	18-3074	68F-13907-00-00	18-7342
65W-14198-00-00	18-76689	676-13646-A0	18-99080	682-44365-00	18-1834	68F-13907-01-00	18-7342
65W-14457-10	18-99071	676-14984-00-00	18-0840-1	682-44366-00	18-1831	68F-13915-00-00	18-79904
65W-24251-10-00	18-7830	676-14985-01-00	18-7392	682-44367-00	18-1832	68F-24563-00	18-79980
65W-41114-00	18-99072	676-41112-A0	18-99081	682-45113-A1	18-99022	68F-24563-10-00	18-7955
65W-41114-01-00	18-60531	676-41133-A0	18-99014	682-82556-00-00	MP28860	68F-41114-00	18-99101
65W-43865-00-00	18-7470	676-44315-A1	18-99082	682-W0001-06	18-99097	68F-45113-00	18-99102
65W-43871-00-00	18-7484	676-44324-A0	18-99083	682-W0078-A1-00	18-3148	68F-46241-10-00	18-15145
65W-46241-00-00	18-15135	676-45114-A0	18-99015	682-W0078-A1-00	18-3411	68F-81800-01-00	18-6426
65W-81941-00-00	18-5819	676-45127-00	18-99084	683-45315-A0	18-99152	68F-8592A-00-00	18-7656
65W-85570-01-00	18-23205	676-45128-00	18-99085	683-W0001-C1-00	18-74501	68F-W0001-01	18-99103
65W-W0001-20	18-99073	677-14198-A1	18-99145	688-11181-02-00	18-3805	68F-W1135-00-00	18-64415
662-44352-01-00	18-3063	677-14384-01	18-99146	688-11181-A1-00	18-3805	68T-13475-00	18-99027
663-13622-00-00	18-0242	677-24411-02-00	18-7837	688-11193-01-00	18-0767	68T-24251-00-00	18-7710-1
663-13622-A0-00	18-0242	677-24471-01-00	18-7838	688-11603-A0-00	18-3969	68T-44323-00-00	18-3142
663-24410-00-00	18-7334	677-W0093-00-00	18-7059	688-11650-03-00	18-1756	68T-44352-00-00	18-8910
663-24411-00-00	18-7840	677-W0093-04-00	18-7059	688-12414-A1-00	18-0844	68T-44366-00-00	18-3176
663-44311-02	18-3408	679-44316-A0	18-99086	688-13621-A1	18-99098	68T-46241-00-00	18-15138
663-44315-A0-00	18-0292	679-45315-A0	18-99087	688-41112-A0-00	18-0847	68T-W0001-20-00	18-74544
663-44316-A0	18-99149	679-W0078-00-00	18-3397	688-41114-A0	18-99148	68T-W0078-00-00	18-3410
663-44322-00-00	18-3435	679-W0078-A0-00	18-3397	688-41133-00	18-99023	68T-W0078-00-00	18-3450
663-44323-00-00	18-3436	67C-11356-00	18-99088	688-41134-A0	18-99024	68V-11325-01-00	18-6118A
663-44324-A0-00	18-0294	67C-41114-00	18-99089	688-43880-11-00	18-6821	68V-13766-00-00	18-2083
663-44366-00	18-1828	67C-41133-00	18-99016	688-44311-01-00	18-3171	68V-13907-00-00	18-7340
663-44366-00	18-1830	67C-43880-00-00	18-6748	688-44315-A0-00	18-0239	68V-13907-01-00	18-7340
663-45123-00	18-99009	67C-43880-01-00	18-6748	688-44316-A0-00	18-0240	68V-13907-02-00	18-7340
663-45331-00-94	18-2773	67C-45113-00	18-99091	688-44352-03-00	18-3070	68V-13907-03-00	18-7340
663-81840-11-00	18-56004	67C-45123-00	18-99017	688-45113-A0	18-99151	68V-13915-00-00	18-79903
663-W0078-00-00	18-3425	67C-W0001-00	18-99092	688-45114-A1	18-99025	68V-14984-00	18-0710
663-W0078-A0-00	18-3425	67C-W0001-20	18-99093	688-45123-00	18-99026	68V-15312-00	18-99028
664-41114-A0-00	18-0250	67C-W0001-21-00	18-0020	688-45331-00-94	18-2782	68V-24502-00-00	18-79986
664-41134-A0	18-99010	67D-14301-13-00	18-34601	688-45341-00-00	18-2374	68V-24502-01-00	18-79986
664-45371-01-00	18-6096	67D-15713-00-00	18-51002	688-45341-00-00	18-23741-9	68V-24502-02	18-79986
66K-13907-00-00	18-7341	67D-24410-03-00	18-35304	688-45341-10-00	18-2374	68V-24502-20-00	18-79985
66K-13915-00-00	18-79900	67D-45113-A0-00	18-60527	688-45341-10-00	18-23741-9	68V-24502-30	18-79985
66K-14984-00	18-0711	67D-W0093-00-00	18-7736	688-45371-02-00	18-6070	68V-24563-00-00	18-7979
66K-W0001-20-00	18-74512	67F-11181-02	18-99094	688-45371-02-00	18-6111	68V-44323-00-00	18-3521
66M-11181-10-00	18-63966	67F-12411-01-00	18-3632	688-45611-00-00	18-2388	68V-45123-00-00	18-0618
66M-11351-10	18-99074	67F-14371-01	18-79972	688-45997-01-00	18-4274	68V-81800-01-00	18-6427
66M-11356-00	18-99075	67F-24251-02-00	18-7516	688-81800-12-00	18-6423	68V-W0001-20-00	18-74515
66M-11357-00-00	18-60513	67F-41133-A1	18-99018	688-81941-00-00	18-5879	68V-W0078-00	18-3523-1
66M-12411-01-00	18-3541	67F-41134-A0	18-99019	688-81950-10-00	18-5879	68V-W0078-00-00	18-3442
66M-13329-10	18-99076	67F-41138-00-00	18-0605	688-85540-16-00	18-5130	692-14590-00-00	18-7060
66M-13645-00-00	18-60534	67F-43880-00-00	18-6787	688-W0001-00-00	18-4415	692-14590-01-00	18-7060
66M-14301-00-00	18-34600	67F-44311-01	18-3409	688-W0001-20-00	18-2798	692-24410-00-00	18-7334
66M-14301-12-00	18-34600	67F-44322-00-00	18-3162	688-W0001-22-00	18-0021	692-24411-00-00	18-7391
66M-24410-10-00	18-35302	67F-44323-00-00	18-3143	688-W0001-A0-00	18-4415	692-W0078-00-00	18-3370
66M-41114-01-00	18-60530	67F-44352-00-00	18-3042	688-W0001-C0-00	18-2798	692-W0078-01-00	18-3370
66M-41133-00	18-99012	67F-45123-00	18-99020	689-11181-02-00	18-3804	692-W0078-A0-00	18-3370
66M-41138-00	18-99078	67F-45127-00-00	18-0617	689-11631-00-95	18-4138	692-W0078-A0-00	18-3371
66M-45113-00	18-99013	67F-46241-00-00	18-15131	689-15755-01-00	18-50000	695-11181-A0-00	18-3849
66M-45115-00	18-99079	67F-81800-02-00	18-6425	689-44352-02-00	18-3067	695-11181-A1-00	18-3849
66M-46241-00-00	18-15137	67F-82341-00-00	18-5217-1	689-45113-A1-00	18-0739	695-85540-12-00	18-5131
66M-81800-01-00	18-6943	67F-82341-00-00+	18-8847-1	689-81311-40-00	18-5195	695-85570-10-00	18-5112
66M-81800-02-00	18-6943	67F-82342-00-00	18-5218-1	689-81800-11	18-6410	695-W0001-01-00	18-4417
66M-85520-00-00	18-25600	67F-82342-00-00+	18-8847-1	689-81800-12	18-6410	695-W0001-02-00	18-4417
66M-85540-01-00	18-25300	67F-82343-00-00	18-5219-1	689-81800-13-00	18-6410	695-W0001-A2-00	18-4417
66M-85570-00-00	18-23601	67F-82343-00-00+	18-8847-1	689-81840-11-00	18-56002	696-W0093-02-00	18-7290
66M-85580-00-00	18-25650	67F-82344-00-00	18-5220-1	689-W0001-21-00	18-2785	697-11181-A0-00	18-3848
66M-W0093-00-00	18-7738	67F-82344-00-00	18-8847-1	689-W0001-23-00	18-0022	697-11181-A1-00	18-3848
		67F-W0001-20-00	18-74535	689-W0001-A1-00	18-3804	697-44352-00-00	18-3069

O.E. #	SIERRA #	O.E. #	SIERRA #	O.E. #	SIERRA #	O.E. #	SIERRA #
YAMAHA cont.		6CB-13016-00	18-0707	6E5-85570-11-00	18-5110	6G5-11181-A0-00	18-3894
697-45114-A0	18-99030	6CB-13915-00	18-79978	6E5-W0001-51-00	18-2794-1	6G5-11193-A0-00	18-0779
697-81800-12	18-6412	6CB-14984-00	18-0716	6E5-W0001-F1-00	18-2794-1	6G5-11382-A1-00	18-0808
697-85570-11-00	18-5111	6CB-24501-00	18-79979	6E5-W0078-01-00	18-3372	6G5-11631-00-93	18-4129
698-W0001-20-00	18-2787	6CB-44315-00-00	18-0451	6E5-W0078-A1-00	18-3373	6G5-11636-00-00	18-4133
698-W0001-21-00	18-0024	6CB-44323-00-00	18-4572	6E5-W0093-06-00	18-7002	6G5-11642-00-93	18-4128
698-W0001-C0-00	18-2787	6CB-81800-00-00	18-6961	6E7-11181-00-00	18-3828	6G5-13645-A1-00	18-0809
69G-W0001-20-00	18-0025	6CB-W0078-00-00	18-3474	6E7-11181-A1-00	18-3828	6G5-14483-A1	18-99118
69G-W0078-00	18-3475	6CB-W4624-00-00	18-15134	6E7-11631-00-97	18-4135	6G5-41112-A1-00	18-0812
69J-13440-00-00	18-7906-1	6CE-12411-00-00	18-3524	6E7-14227-00	18-99144	6G5-41134-A1	18-99039
69J-13440-01-00	18-7906-1	6CE-44311-01-00	18-3482	6E7-14385-00-00	18-7393	6G5-43864-00-00	18-7468
69j-13907-04-00	18-7339	6CE-44315-00-00	18-3458	6E7-14390-12-00	18-7073	6G5-43880-02-00	18-6760
69J-13907-04-00	18-7345	6CE-44323-01-00	18-3459	6E7-85570-10-00	18-5112	6G5-44323-00-00	18-3345
69J-24501-00	18-79981	6CE-44352-00-00	18-45617-1	6E7-85570-19-00	18-5112	6G5-45113-A0-00	18-0813
69J-24501-10-00	18-79905	6CE-W0078-01	18-3470	6E7-W0093-04-00	18-7769	6G5-45114-A1	18-99040
69J-24502-00	18-79982	6CE-W0078-01+6CE-44311-01	18-3471	6E8-14380-12-00	18-7073	6G5-45251-01-00	18-6090
69J-41134-A0	18-99032	6CJ-44311-00-00	18-3485	6E9-11193-A0	18-99106	6G5-W0001-03-00	18-4404
69J-41135-A0	18-99033	6CJ-44315-00	18-0448	6E9-12414-A1	18-99142	6G5-W0001-21-00	18-2794-1
69J-41136-A0	18-99034	6CJ-44316-00	18-0449	6E9-41114-A0	18-99107	6G5-W0001-A3-00	18-4404
69J-41138-00-00	18-0619	6CJ-44324-00	18-0450	6E9-82575-02-00	18-65450	6G5-W0001-C1-00	18-2794-1
69J-43880-00-00	18-6798	6CJ-W0078-00-00	18-3494	6E9-W0093-02-00	18-7740	6G5-W0078-01-00	18-3310
69J-45123-00-00	18-0656	6D3-81800-00-00	18-6907	6E9-W0093-03-00	18-7741	6G5-W0078-A1-00	18-3311
69J-46241-00-00	18-15141	6D8-WS24A-00-00	18-79799	6EE-G4311-00	18-4567	6G5-W0093-08-00	18-7747
69J-81800-00-00	18-6833	6DA-12411-01-00	18-3636	6EE-G4322-00	18-4546	6G5-W4599-00-00	18-3782
69L-45371-00-00	18-6122A	6DA-W4624-00-00	18-15142	6EE-G4323-00	18-4573	6G8-11181-00-00	18-3827
69L-45371-00-00	18-6122Z	6E0-24411-00-00	18-7389	6EE-G4366-00	18-1840	6G8-11181-A1-00	18-3827
69L-81800-00-00	18-6861	6E0-24471-00-00	18-7834	6EE-W0078-00-00	18-3473	6G8-11351-A0	18-99119
69M-11181-00-00	18-60523	6E0-44352-00-00	18-3073	6EG-G4315-00	18-99157	6G8-12414-A0	18-99120
69M-11196-A0-00	18-60521	6E0-44366-00-00	18-3166	6EG-G4322-00	18-4547	6G8-13440-00-00	18-7901
69M-12411-01-00	18-3624	6E0-W0001-C1-00	18-0028	6EG-G4323-00	18-4574	6G8-13646-A0	18-99121
69M-14301-11-00	18-34604	6E5-11181-02-00	18-3832	6EG-G4328-00	18-9089	6G8-14198-A0	18-99122
69M-G4323-00	18-0409	6E5-11181-A1-00	18-3832	6EG-W0078-00-00	18-4532	6G8-15374-00	18-99123
69M-G4328-00	18-9091	6E5-11193-A0-00	18-0781	6EK-12411-00-00	18-3639	6G8-45113-A1	18-99045
69M-WG078-00-00	18-4534	6E5-11381-A1-00	18-0782	6F3-W0001-04-00	18-4403	6G8-46241-00-00	18-15133
69W-43880-00-00	18-6811	6E5-11610-03-00	18-3934	6F3-W0001-21-00	18-2794-1	6G9-W0001-C6-00	18-74527
69W-81800-00	18-6861	6E5-11610-23-00	18-3936	6F3-W0001-A4-00	18-4403	6GD-G4325-00-00	18-1079
69W-81800-00-00	18-6942	6E5-12411-02-00	18-3623	6F3-W0001-C1-00	18-2794-1	6H0-W0093-00-00	18-7742
6A0-24410-00-00	18-7334	6E5-12411-30-00	18-3540	6F5-12411-03-00	18-3625	6H1-11631-03-95	18-4097
6A0-24410-01-00	18-7334	6E5-13411-00	18-79975	6F5-24563-00-00	18-7780	6H1-11636-03-00	18-4099
6A0-24410-02-00	18-7334	6E5-13621-A1	18-99105	6F5-44352-00-00	18-3088	6H1-13411-00	18-79961
6A0-24410-03-00	18-7334	6E5-13645-A1-00	18-0823	6F5-81800-11	18-6421	6H1-43880-00-00	18-6259
6A0-24410-04-00	18-7334	6E5-14198-A1-00	18-0785	6F5-85540-21-00	18-5136	6H1-43880-02-00	18-6781
6A0-24410-05-00	18-7334	6E5-14384-02-00	18-0786	6F5-85540-22-00	18-5136	6H1-45251-02-00	18-6091
6A0-W0001-21	18-99104	6E5-14384-03-00	18-2592	6F5-W0078-00-00	18-3398	6H1-81950-01-00	18-1524
6A1-W0001-22-00	18-0026	6E5-14385-00-00	18-7068	6F5-W0078-A0-00	18-3398	6H1-W0001-00-00	18-4405
6A1-W0001-23-00	18-0027	6E5-14385-01-00	18-7068	6FM-44323-01	18-4576	6H1-W0001-01-00	18-4405
6A1-W0078-01-00	18-3463	6E5-14385-02-00	18-7069	6FM-W0078-00-00	18-4527	6H1-W0001-A0-00	18-4405
6A1-W0078-02-00	18-3462	6E5-14546-00-00	18-7055	6FP-12411-00-00	18-3641	6H1-W0093-01-00	18-7291
6A1-W0093-01-00	18-7293	6E5-24305-05	18-80415	6G1-11193-A1	18-99108	6H1-W4599-00-00	18-3781
6AH-44311-00-00	18-3484	6E5-24410-00-00	18-7349	6G1-13621-A1	18-99109	6H2-14591-00-00	18-7056
6AH-46241-00-00	18-15136	6E5-24410-01-00	18-7349	6G1-13645-A1	18-99110	6H2-81960-00-00	18-6858
6AH-W0078-00	18-3479	6E5-24410-02-00	18-7349	6G1-14198-A1	18-99111	6H3-11181-01-00	18-3831
6AW-12411-00-00	18-3634	6E5-24410-03-00	18-7349	6G1-14546-00-00	18-7054	6H3-11181-A1-00	18-3831
6AW-13907-00-00	18-7344	6E5-24410-04-00	18-7349	6G1-14546-01-00	18-7054	6H3-11193-A1	18-99141
6AW-14984-00	18-0714	6E5-24410-10-00	18-7349	6G1-14985-00-00	18-7067	6H3-11631-01-96	18-4091
6AW-24502-00-00	18-79984	6E5-24411-00-00	18-7843	6G1-15755-00-00	18-50001	6H3-11636-01-00	18-4093
6AW-24502-10	18-79984	6E5-24471-00-00	18-7842	6G1-15779-00-00	18-50000	6H3-12411-11-00	18-3622
6AW-44311-01-00	18-3483	6E5-41112-A1-00	18-0799	6G1-15779-00-00	18-50001	6H3-12414-A1	18-99124
6AW-44312-00-00	18-9082	6E5-41134-A0	18-99037	6G1-24305-04	18-80414	6H3-13621-A1	18-99143
6AW-44315-00	18-0452	6E5-41135-A0	18-99038	6G1-24305-05-00	18-80414	6H3-13622-00	18-99125
6AW-44322-00-00	18-3457	6E5-43880-01-00	18-6821	6G1-24411-00-00	18-7388	6H3-14198-01	18-99126
6AW-44323-00	18-0421	6E5-43880-02-00	18-6821	6G1-24431-01	18-99147	6H3-14590-00-00	18-7056
6AW-44336-00	18-3028	6E5-44311-00-00	18-3170	6G1-24471-00-00	18-7833	6H3-14590-01-00	18-7056
6AW-44352-00-00	18-8925	6E5-44312-00-00	18-9081	6G1-41112-A1	18-99112	6H3-41112-A0	18-99128
6AW-44365-00-00	18-1829	6E5-44315-A0-00	18-0244	6G1-41114-A0	18-99113	6H3-41114-A0	18-99129
6AW-W0078-00-00	18-3477	6E5-44323-00-00	18-3344	6G1-41133-A0	18-99114	6H3-44311-00	18-3466
6AW-W4624-00-00	18-15139	6E5-44352-01-00	18-3071	6G1-44315-A0-00	18-0753	6H3-44315-A0-00	18-0756-1
6BG-13915-00	18-79970	6E5-44365-00-00	18-1835	6G1-44322-00-00	18-3456	6H3-44324-A0-00	18-0757
6BG-W0078-00-00	18-3490	6E5-45371-01-00	18-6097	6G1-44352-00-00	18-3066	6H3-44352-00-00	18-3069
6BX-G4315-01-00	18-60541	6E5-45611-01-00	18-2385	6G1-45113-A1	18-99115	6H3-45113-A0	18-99130
6C5-13915-00	18-79973	6E5-81800-11-00	18-6413	6G1-45315-A0	18-99116	6H3-45114-A1	18-99046
6C5-14984-00	18-0717	6E5-81800-12-00	18-6413	6G1-81941-10-00	18-5821	6H3-45123-00	18-99047
6C5-24251-00	18-79983	6E5-81840-10-00	18-56005	6G1-W0001-A2	18-99117	6H3-81800-10	18-6411
6C5-43880-00-00	18-6836	6E5-81941-10-00	18-5853	6G1-W0001-C1-00	18-0029	6H3-81800-11-00	18-6411
6C5-43880-01-00	18-6836	6E5-81941-11-00	18-5853	6G1-W0078-01-00	18-3460	6H3-85510-A1	18-5746
6C5-46241-00-00	18-15130	6E5-85540-10-00	18-5135	6G1-W0078-A1-00	18-3460	6H3-W0001-21-00	18-2788
6CB-12411-10-00	18-3637	6E5-85540-11-00	18-5135	6G1-W0093-00-00	18-7765	6H3-W0001-22-00	18-74504
		6E5-85540-12-00	18-5135	6G5-11181-00-00	18-3894	6H3-W0001-A0-00	18-4427

O.E. #	SIERRA #	O.E. #	SIERRA #	O.E. #	SIERRA #	O.E. #	SIERRA #
YAMAHA cont.				6L2-44328-00	18-9092	90280-04M05-00	18-3302
6H3-W0001-C1-00	18-2788	6L2-44352-00-00	18-3065	90340-08002-00	18-2371	99999-03249-00	18-6412
6H3-W0078-00-00	18-3428-1	6L2-44367-00	18-1836	90340-08002-00	18-23711-9	ABA-FBARB-90-DG	18-8040
6H3-W0078-00-00	18-3461	6L2-44367-10	18-1837	90340-08M04-00	18-2371	ABA-FLINE-BA-RB	18-8055
6H3-W0078-01	18-3466	6L2-45315-A0	18-99138	90340-08M04-00	18-23711-9	ABB-FUELF-IL-TR	18-7845
6H3-W0078-01-00	18-3465	6L2-45987-01-00	18-73979	90340-14M06-00	18-2456	ABB-FUELF-IL-TR	18-7945
6H3-W0078-02-00	18-3465	6L2-81800-20-00	18-6420	904-30142-28-00	18-0755	ABB-SPRTR-HD-SS	18-7777-1
6H3-W0078-02-00	18-3466	6L2-W0001-01-00	18-4422	90430-08020-00	18-4698	LUB-20W40-FC-12	18-9450-2
6H3-W0078-A0-00	18-3428-1	6L2-W0001-02-00	18-4422	90430-08020-00	18-46981-9	LUB-2STRK-M1-4	18-9530-3
6H3-W0078-A0-00	18-3461	6L2-W0001-A2-00	18-4422	90430-14115-00	18-0826	LUB-2STRK-M1-55	18-9530-7
6H3-W0093-02-00	18-7766	6L2-W0001-C3-00	18-0030	90430-14228-00	18-0755	LUB-MRNLG-KT-10	18-9393
6H4-11181-00-00	18-3830	6L2-W0078-00-00	18-3431	90430-14M09-00	18-0755	LUB-MRNMD-KT-10	18-9391
6H4-11181-A1-00	18-3830	6L2-W0093-00-00	18-7739	91401-30028-00	18-2380	LUB-MRNMR-KT-10	18-9392
6H4-11193-A1-00	18-0815	6L5-24251-00	18-79977	91401-30030-00	18-2380	LUB-MRNSM-KT-10	18-9390
6H4-11610-00-00	18-3960	6L5-44322-00-00	18-3164	91402-30022-00	18-2380	MAR-10171-00-10	18-7924
6H4-11610-10-00	18-3961	6L5-44323-00-00	18-3163	91402-30022-09	18-2380	MAR-10171-30-00	18-7606
6H4-11610-20-00	18-3962	6L5-44352-00-00	18-8911	91402-30028-00	18-2380	MAR-24563-00-00	18-7919
6H4-11631-00-96	18-4141	6L5-45616-00-00	18-73892	91402-30028-09	18-2380	MAR-FLTHD-AL-12	18-7853-1
6H4-11635-01-00	18-4142	6M6-81800-10-00	18-6862	91490-25030-00	18-73893	MAR-FLTHD-SS-12	18-7777
6H4-11636-00-00	18-4143	6M6-8183E00-00	18-15080	91490-30030-00	18-2380	MAR-FUELF-IL-TR	18-7866
6H4-13621-A1	18-99132	6M6-81960-A0-00	18-6650	91490-30045-00	18-3748	MAR-MINIF-IL-TR	18-7865
6H4-14198-01	18-99133	6N0-W0001-C0-00	18-0031	91490-40030-00	18-3735	MAR-MINIF-LT-AS	18-7965-1
6H4-15369-A1	18-99134	6N0-W0078-A0-00	18-3460	92900-10600-00	18-0192	MAR-SEPAR-AT-OR	18-7852-1
6H4-41112-A0	18-99135	6N6-W0001-03-00	18-4411	92901-10600-00	18-0192	MAR-SEPAR-AT-OR	18-7966-1
6H4-41114-A0-00	18-0798	6N6-W0001-A3-00	18-4411	92902-10600-00	18-0192	MAR-SPRTR-HD-SS	18-7984-1
6H4-44352-02-00	18-3068	6N6-W0078-00-00	18-3312	92903-10600-00	18-0192	N26-13440-00-00	18-7954
6H4-81800-12-00	18-6422	6N6-W0078-01-00	18-3313-1	92990-06600-00	18-0191	N26-13440-02-00	18-7954
6H4-W0001-01-00	18-4407	6N6-W0093-02-00	18-7744	92990-10600-00	18-0192	YB-6AW04-1	18-9133-9
6H4-W0001-02-00	18-4419	6N7-81800-10-00	18-6415	92995-10600-00	18-0192	YB-6AW04-3	18-9146-9
6H4-W0001-03-00	18-4409	6N7-81840-00-00	18-56006	93101-20M07-00	18-0554	YB-6AW04-A	18-9145
6H4-W0001-04-00	18-4409	6OV-13646-00	18-99139	93101-22067-00	18-0296	YB-ACC04	18-79815
6H4-W0001-20-00	18-2792	6P2-14984-00	18-0713	93101-22M15-00	18-2079	YSC-10231-20-0C	18-7824-2
6H4-W0001-21-00	18-2792	6P2-44323-00-00	18-3518	93101-23070-00	18-0297	YSC-10260-00-0C	18-15111
6H4-W0001-A1-00	18-4407	6P2-46241-02-00	18-15132	93101-25M03-00	18-0587	YSC-10260-10-0C	18-15110
6H4-W0001-A2-00	18-4419	6P2-W0078-00-00	18-3515	93101-28M16-00	18-0265	YSC-12190-00-AC	18-2909
6H4-W0078-00	18-3408	6P2-WS245-00-00	18-7518	93101-30M17-00	18-0266	YSC-13080-00-0C	18-0164
6H4-W0078-00-00	18-3429	6P3-24564-00-00	18-7488	93102-23096-00	18-0570	YSC-13231-20-0C	18-7824-2
6H4-W0078-A0	18-3408	6P3-WS24A-00-00	18-79809	93102-25M28-00	18-0588	YSC-13260-60-0C	18-15106
6H4-W0078-A0-00	18-3429	6R3-85570-01-00	18-5128	93102-35M13-00	18-2085	YSC-14231-20-0C	18-7876-1
6H4-W0093-01-00	18-7767	6R3-W0001-03-00	18-4412	93102-40M36-00	18-2087	YSC-16231-20-0C	18-7875
6H4-W0093-03-00	18-7768	6R3-W0001-A3-00	18-4412	93104-22M07-00	18-2091	YSC-22260-00-0C	18-15109
6H4-W4599-00-00	18-73990	6R5-11603-00	18-39320	93106-09014-00	18-0267	YSG-10108-43-8G	18-0876
6H5-43880-02-00	18-6788	6R5-11631-11-93	18-4081	93210-05001	18-71330	YSG-10108-44-5G	18-0874
6J4-81800-01-00	18-6421	6R5-11635-11-00	18-4083	93210-16716-00	18-7511-9	YSG-10114-14-1G	18-0889
6J8-11181-00-00	18-3829	6R5-11636-11-00	18-4085	93210-19123-00	18-7463	YSG-14090-90-8G	18-0905
6J8-11181-A1-00	18-3829	6R5-11642-11-93	18-4080	93210-24M79	18-76694	YSG-14096-15-6G	18-0887
6J8-12414-A0-00	18-0829	6R5-11645-11-00	18-4082	93210-27ME3-00	18-76691	YSG-37545-87-G0	18-0891
6J8-13411-00	18-79974	6R5-11646-11-00	18-4084	93210-31MJ5-00	18-76693	YSG-38600-39-G0	18-0903
6J8-14546-00-00	18-7055	6R5-11650-10-00	18-4157	93210-32738-00	18-7432	YANMAR	
6J8-24471-00-00	18-7841	6R6-W0001-01-00	18-4413	93210-33M85-00	18-7119	104211-42070	18-3079
6J8-81960-00-00	18-17301	6S5-81800-00-00	18-6909	93210-37M67-00	18-7483	104211-42071	18-8952
6J8-W0001-21-00	18-2789	6Y1-24305-04	18-80413	93210-41042-00	18-0298	104211-49160	18-56601
6J8-W0001-C2-00	18-2789	6Y2-24305-05	18-80415	93210-44704	18-71331	104211-77010	18-6930
6J8-W0078-A1-00	18-3430	6YL-24306-60-00	18-8017EP-2	93210-45161	18-71332	104211-77011	18-6930
6J9-45371-01-00	18-6035	6YL-24306-60-00	18-8017S-1	93210-46044-00	18-7436	104500-55710	18-79960
6J9-45371-01-00	18-6112	703-82510-12-00	MP51020	93210-46M16-00	18-76690	114361-77011	18-6936
6K1-45371-00-00	18-6034	703-82510-12-00	MP51022	93210-49046	18-71333	114362-77010	18-6936
6K1-45371-02-00	18-6121A	703-82510-43-00	MP51040	93210-54M54-00	18-7439-9	114362-77011	18-6936
6K1-45371-02-00	18-6121Z	703-82510-43-00	MP51042	93210-59MG7	18-71334	114399-77010	18-6936
6K1-82510-06-00	MP51050	90105-10M00-00	18-6246	93210-66M98-00	18-0299	119209-77010	18-6931
6K1-82510-06-00	MP51052	90119-08M13-00	18-2606	93210-74M35-00	18-7442	119225-77010	18-6935
6K5-11601-02-00	18-3963	90119-08M15-00	18-8400-9	93210-75M51-00	18-76692	119225-77011	18-6935
6K5-11636-03-00	18-4096	90119-08M33	18-0260	93210-86M38-00	18-7485	119226-77010	18-6935
6K7-13645-A1-00	18-0807-1	90119-08M87-00	18-2605	93210-94003-00	18-7471	119350-35150	18-7910-1
6K7-13686-A1	18-99136	90171-10M01	18-3773	93210-97M55-00	18-0275	119350-35151	18-7910-1
6K7-W0093-09-00	18-7759	90171-14056-00	18-3792	93211-04384-00	18-7444	119573-77200	18-6927
6K8-81960-A0-00	18-6652	90171-14056-00	18-73907	93310-32337-00	18-1410	119573-77200	18-6929
6L2-11181-A1-00	18-3847	90171-16011-00	18-3732	93310-620V5-00	18-1411	119573-77201	18-6927
6L2-11181-A2-00	18-3847	90201-08M54-00	18-73978	93310-730V8-00	18-4077	119573-77201	18-6929
6L2-14384-00-00	18-0765	90201-22M01	18-9078	93310-836V2-00	18-4078	119574-42550	18-45714
6L2-14385-00-00	18-7063	90201-22M01	18-9079	93604-10M03-00	18-43717	119574-42552	18-45714
6L2-14392-00-00	18-7049	90206-22M19	18-9077	93604-18080-00	18-43716	119773-42600-00	18-3306
6L2-41112-A1-00	18-0743	90206-22M19+	18-9079	95307-16900-00	18-3732	119773-77010	18-6938
6L2-41114-A1-00	18-0744	90280-03003-00	18-3305	97080-06045	18-0261	119773-77200	18-6849
6L2-41133-A2	18-99137	90280-03024-00	18-3305	97080-08045-00	18-0256	119836-77200	18-6926
6L2-44311-01-00	18-3486	90280-03M03-00	18-3297	97095-06040-00	18-2607	119836-77200-2	18-6926
6L2-44322-00	18-4548	90280-04M00-00	18-3300	97095-08045-00	18-0256	119836-77200-3	18-6926
		90280-04M04-00	18-3301	97595-06535	18-8406		

O.E. #	SIERRA #	O.E. #	SIERRA #	O.E. #	SIERRA #	O.E. #	SIERRA #
YANMAR cont.							
121120-77010	18-6931						
121120-77011	18-6931						
121120-77012	18-6931						
121254-77010	18-6939						
121254-77011	18-6939						
121254-77012	18-6939						
121254-77019	18-6939						
121370-77010	18-6932						
123500-77010	18-6934						
124085-35113	18-7917						
124223-42092	18-8950						
124450-35100	18-7910-1						
124450-35110	18-7917						
124520-77010	18-6931						
124520-77011	18-6931						
124550-35110	18-7917						
124610-77010	18-6934						
124610-77019	18-6934						
127610-42200	18-3077						
128170-01331	18-55600						
128170-11310	18-56000						
128170-42090	18-56602						
128170-77010	18-6937						
128170-77010D	18-6937						
128170-77200	18-6928						
128170-77201	18-6928						
128170-77202	18-6928						
128171-01911	18-55601						
128171-12540	18-57704						
128176-42071	18-8951						
128270-12540	18-57703						
128270-77200	18-6925						
128271-01911	18-55602						
128374-01911	18-55603						
129242-77010	18-6932						
129429-77010	18-6939						
129429-77011	18-6939						
129470-77200	18-6927						
129470-77200	18-6970						
129573-77010	18-6880						
129612-77230	18-6926						
129698-77010	18-6932						
171008-77010	18-6880						
171056-35110	18-7917						
171056-35111	18-7917						
192470-42530	18-3277						
192470-42532	18-3277						
27210-200200	18-6200						
27210-200300	18-6201						
424610-77010	18-6934						
728170-92600	18-55500						
728171-92601	18-55501						
728271-92605	18-55502						
8M0095471	18-55510						
ZENITH							
K-2035	18-7732						
K-2036	18-7732						

ÍNDICE REFERENCIAS / NÚMERO DE PÁGINA

Referencia	Descripción	Página
009353	ANODO ZINC	111
009370	ANODO ZINC	111
012321	CONECTOR COMBUSTIBLE	376
016734	ABRAZADERAS INOXIDABLES NORMA	271
025299	ANODO ZINC	111
025301	ANODO ZINC	111
025390	ANODO ZINC	112
025839	ANODO ZINC	112
025846	ANODO ZINC	112
025847	ANODO ZINC	112
025849	ANODO ZINC	111
025850	ANODO ZINC	111
112317	CONECTOR GASOLINA	51, 52, 53
112322	ENSAMBLAJE DE LINEA DE COMBUSTIBLE DE LONG	357, 358
112324	CONECTOR COMBUSTIBLE	339
112325	ENSAMBLAJE DE LINEA DE COMBUSTIBLE DE LONG	357, 358
112351	COMPONENTES DE LA LÍNEA DE COMBUSTIBLE	270, 357
112355	COMPONENTES DE LA LÍNEA DE COMBUSTIBLE	270, 357
112356	COMPONENTES DE LA LÍNEA DE COMBUSTIBLE	270, 357
112357	ENSAMBLAJE DE LINEA DE COMBUSTIBLE DE LONG	357
112358	COMPONENTES DE LA LÍNEA DE COMBUSTIBLE	270
112361	COMPONENTES DE LA LÍNEA DE COMBUSTIBLE	270
112363	COMPONENTES DE LA LÍNEA DE COMBUSTIBLE	270
112364	COMPONENTES DE LA LÍNEA DE COMBUSTIBLE	270
186408	ALTERNADOR	39
603200	ANODO ALUMINIO	112
603201	ANODO ALUMINIO	112
603202	ANODO ALUMINIO	112
2170300	ARRANQUE RÁPIDO	16
2172300	EVITA LAS PÉRDIDAS DE ACEITE	16
2172400	DIESEL ANTIFROTZ	16
2211700	EVALUADOR DE ANTICONGELANTE	16
2212200	CONCENTRADO ANTICONGELANTE PARA EL MOTOR	16
2213300	LIMPIADOR EN FRIJO PARA EL MOTOR	16
2214400	CONSERVAR EL MOTOR+EL CARBURADOR	16
2456800	LIMPIADOR DE SISTEMA DE REFRIGERACIÓN	16
2456900	CONSERVAR EL INTERIOR DEL MOTOR	16
221221810	CONCENTRADO ANTICONGELANTE PARA EL MOTOR	16
221222489	CONCENTRADO ANTICONGELANTE PARA EL MOTOR	16
025759 Zinc	ÁNODO	225
009110 Zinc	ÁNODO	310
009317Zinc 603132AL	ÁNODO	225
009318Zinc 603153 AL	ÁNODO	225
009319 Zinc 603124 AL	ÁNODO	225
009322 Zinc	ÁNODO	310
009322 Zinc	ÁNODO	366

Referencia	Descripción	Página
009322Zinc 603123AL	ÁNODO	225
009323Zinc	ÁNODO	226
009324Zinc	ÁNODO	226
009357 Zinc	ÁNODO	309
009358 Zinc	ÁNODO	310
009359 Zinc	ÁNODO	310
009360 Zinc	ÁNODO	344
009364Zinc	ÁNODO	226
009366Zinc	ÁNODO	226
009367Zinc	ÁNODO	226
009368Zinc	ÁNODO	225
009368Zinc	ÁNODO	227
009371Zinc 603046AL 18-6244 M	ANODOS	110
009373Zinc	ÁNODO	226
009374Zinc	ÁNODO	226
009375Zinc	ÁNODO	226
009428Zinc	ÁNODO	227
009462 Zinc 009358 603203 AL	ANODO	112
009469Zinc	ÁNODO	227
025304 Zinc	ÁNODO	309
025339Zinc 603154 AL	ÁNODO	225
025340Zinc	ÁNODO	227
025341 Zinc	ÁNODO	344
025342 Zinc	ÁNODO	345
025343 Zinc	ÁNODO	344
025344 Zinc	ÁNODO	344
025345 Zinc	ÁNODO	345
025392 Zinc	ÁNODO	367
025393 Zinc	ÁNODO	367
025401 Zinc	ÁNODO	345
025406 Zinc	ÁNODO	310
025418 Zinc	ÁNODO	366
025440 Zinc	ÁNODO	366
025507 Zinc	ÁNODO	310
025742 Zinc	ÁNODO	345
025750 Zinc	ÁNODO	310
025756Zinc 603127AL	ÁNODO	225
025757 Zinc 603125AL	ÁNODO	225
025757Zinc	ÁNODO	226
025758Zinc	ÁNODO	226
025834 Zinc	ÁNODO	345
025840Zinc	ÁNODO	227
025842 Zinc	ÁNODO	344
025843 Zinc	ÁNODO	345
025844 Zinc	ÁNODO	344
025849 18-6014 A	ANODOS	110
025856 Zinc	ÁNODO	366
025899 Zinc	ÁNODO	310
025987 Zinc	ÁNODO	310
112315 18-8068 18-8082	CONECTOR	51/52
125848Zinc 603049 AL	ANODOS PLACA MONTAJE	111
18-7247	KIT CARBURADOR	153

Referencia	Descripción	Página
18-0021	KIT RETÉN ALOJAMIENTO ENGRANAJE	322
18-0022	KIT RETÉN ALOJAMIENTO ENGRANAJE	322
18-0023	KIT RETÉN ALOJAMIENTO ENGRANAJE	322
18-0024	KIT RETÉN ALOJAMIENTO ENGRANAJE	322
18-0025	KIT RETÉN ALOJAMIENTO ENGRANAJE	322
18-0026	KIT RETÉN ALOJAMIENTO ENGRANAJE	323
18-0027	KIT RETÉN ALOJAMIENTO ENGRANAJE	323
18-0028	KIT RETÉN ALOJAMIENTO ENGRANAJE	323
18-0029	KIT RETÉN ALOJAMIENTO ENGRANAJE	323
18-0030	KIT RETÉN ALOJAMIENTO ENGRANAJE	323
18-0031	KIT RETÉN ALOJAMIENTO ENGRANAJE	323
18-0102	JUNTA COLECTOR ESCAPE	196
18-0103	JUNTA BASE	90
18-0105	JUNTA PLATINA	88
18-0106	JUNTA COLECTOR ESCAPE	196
18-0107	JUNTA TAPA ESCAPE	88
18-0108	JUNTA CAJA ENGRANALA	199
18-0110	JUNTA	199
18-0117	JUNTA PLATINA ESCAPE	196
18-0118	JUNTA CARBURADOR	194
18-0120	JUNTA PLATINA ESCAPE	196
18-0122	JUNTA	195
18-0122	JUNTA BASE MOTOR	197
18-0124	JUNTA IMPULSOR PLATINA	199
18-0126	JUNTA TAPA ESCAPE	196
18-0128	JUNTA BASE MOTOR	197
18-0129	JUNTA	88
18-0130	JUNTA CAJA	195
18-0131	JUNTA	88
18-0133	JUNTA PLATINA	88
18-0134	JUNTA CARBURADOR	194
18-0135	JUNTA ADAPTADOR	90
18-0136	JUNTA BASE MOTOR	197
18-0137	JUNTA PLATINA	88
18-0138	JUNTA BASE MOTOR	197
18-0139	JUNTA BASE	90
18-0140	JUNTA	195
18-0142	JUNTA COLECTOR	195
18-0144	JUNTA CAJA	195
18-0148	JUNTA COLECTOR	195
18-0151	JUNTA TAPA ESCAPE	89
18-0155	JUNTA MONTAJE RECTIFICADOR	199
18-0157	JUNTA	195
18-0159	JUNTA	195
18-0161	JUNTA COLECTOR INFERIOR	195
18-0176	JUNTA BOMBA AGUA	364
18-0182	JUNTA TERMOSTATO	91, 198
18-0191	ARANDELA	293
18-0192	FILTRO ACEITE	293
18-0195	ARANDELA EMPUJE	215
18-0197	ARANDELA EMPUJE	215
18-0198	ARANDELA EMPUJE	215
18-0200	ARANDELA EMPUJE	215
18-0201	ARANDELA EMPUJE	215
18-0202-9	MUELLE	108
18-0232	JUNTA TAPA	89, 306
18-0239	JUNTA BOMBA AGUA	307
18-0240	JUNTA BOMBA AGUA	307
18-0242	JUNTA VÁLVULA	302
18-0244	JUNTA BOMBA AGUA	307
18-0248	JUNTA COLECTOR ADMISIÓN	365
18-0250	JUNTA TAPA ESCAPE	306
18-0256	TORNILLOS	274
18-0292	JUNTA PLATINA ALOJAMIENTO BOMBA	91, 307
18-0294	JUNTA PLATINA DESGASTE	91, 307

Referencia	Descripción	Página
18-0300	JUNTA COLECTOR ADMISIÓN	365
18-0313	JUNTA VARILLA	199
18-0319	JUNTA BASE	90
18-0320	JUNTA	88
18-0323	JUNTA TERMOSTATO	91
18-0324	JUNTA CARBURADOR	87
18-0333	JUNTA BASE	90
18-0334	JUNTA BASE	90
18-0336	JUNTA BASE	90
18-0339	JUNTA TERMOSTATO	91
18-0341	JUNTA BASE	90
18-0345	JUNTA BOMBA DE AGUA	92
18-0359	JUNTA TAPA SILENCIADOR	88
18-0369	JUNTA BASE	90
18-0371	JUNTA PLATINA	88
18-0372	JUNTA TAPA	89
18-0373	JUNTA PLATINA	88
18-0378	JUNTA BASE	90
18-0380	JUNTA TERMOSTATO	88
18-0382	JUNTA CUERPO ACELERADOR	365
18-0384	JUNTA CARBURADOR	87
18-0385	JUNTA BASE	90
18-0390	JUNTA COLECTOR ADMISIÓN	365
18-0396	JUNTA CUERPO ACELERADOR	365
18-0397	JUNTA TERMOSTATO	198
18-0406	JUNTA BOMBA DE AGUA	299
18-0412	JUNTA TERMOSTATO	198
18-0437	JUNTA TAPA	194
18-0441	JUNTA TERMOSTATO	198
18-0445	JUNTA BOMBA DE AGUA	199
18-0446	JUNTA BOMBA DE AGUA	199
18-0460	JUNTA BOMBA AGUA	341
18-0461	JUNTA BOMBA AGUA	341
18-0477-9	JUNTA BOMBA AGUA	341
18-0478	JUNTA BOMBA AGUA	341
18-0479	JUNTA BOMBA AGUA	341
18-0483	JUNTA BOMBA	306
18-0491	JUNTA CULATA	192
18-0492	JUNTA CULATA	192
18-0514	RETÉN	93
18-0521	RETÉN	93
18-0522	RENESES ACEITE	367
18-0539	RETÉN	93
18-0540	RETÉN GOMA	200
18-0544	RETÉN ACEITE	347
18-0545	RETÉN ACEITE	347
18-0551	RETÉN ACEITE	347
18-0557	RETÉN INFERIOR	103
18-0563	RETÉN	93
18-0568-9	CASQUILLO	94
18-0569	RETÉN ACEITE	347
18-0583	RENESES ACEITE	367
18-0605	RETÉN COLECTOR ESCAPE	299
18-0617	RETÉN ESCAPE	299
18-0618	JUNTA COLECTOR ESCAPE	299
18-0619	RETÉN TUBO ESCAPE	299
18-0622	JUNTA PLATINA INFERIOR	92
18-0624	JUNTA ATENUADOR	88
18-0626	JUNTA TAPA	194
18-0628	JUNTA TAPA	194
18-0633	JUNTA CARBURADOR	87
18-0641	JUNTA CARBURADOR	87
18-0642	JUNTA	89
18-0643	JUNTA BASE	90
18-0644	JUNTA PLATINA	88

Referencia	Descripción	Página
18-0645	JUNTA PLATINA	88
18-0646	JUNTA PLATINA	88
18-0649	JUNTA ALOJAMIENTO CAMBIO	90
18-0650	JUNTA ALOJAMIENTO RETÉN DE ACEITE	344
18-0651	JUNTA PANEL BOMBA	344
18-0656	RETÉN TUBO ESCAPE	299
18-0663	KIT DE JUNTAS	78, 297
18-0670	JUNTA BASE	90
18-0675	JUNTA TERMOSTATO	198
18-0679	JUNTA TERMOSTATO	199
18-0690	JUNTA BASE	197
18-0691	JUNTA BASE	197
18-0692	JUNTA BASE	197
18-0693	JUNTA ADMISIÓN	197
18-0694	JUNTA ADMISIÓN	197
18-0695	JUNTA ADMISIÓN	197
18-0696	JUNTA ADMISIÓN	197
18-0707	RETÉN, VITON	262
18-0710	JUNTA CAMARA DE FLOTADOR	261
18-0711	JUNTA CAMARA DE FLOTADOR	261
18-0712	JUNTA CAMARA DE FLOTADOR	261
18-0713	JUNTA CAMARA DE FLOTADOR	261
18-0714	JUNTA CAMARA DE FLOTADOR	261
18-0715	JUNTA CAMARA	45
18-0715	JUNTA CAMARA DE FLOTADOR	262
18-0716	JUNTA CAMARA DE FLOTADOR	262
18-0717	JUNTA CAMARA DE FLOTADOR	262
18-0737	JUNTA CUERPO ACELERADOR	365
18-0739	JUNTA SUPERIOR	306
18-0740	JUNTA CUERPO ACELERADOR	87
18-0743	JUNTA TAPA ESCAPE	306
18-0744	JUNTA TAPA ESCAPE	306
18-0754	JUNTA TERMOSTATO	306
18-0755	JUNTA VACIADO DE CÁRTER	299
18-0756-1	JUNTA BOMBA AGUA	307
18-0757	JUNTA PLATINA	308
18-0761	JUNTA BOMBA AGUA	341
18-0765	JUNTA COMANDO FLOTACIÓN	305
18-0767	JUNTA	306
18-0768	JUNTA PLATINA	308
18-0775	JUNTA MONTAJE	305
18-0778	JUNTA BOMBA AGUA	341
18-0779	JUNTA	306
18-0781	JUNTA	306
18-0782	JUNTA TAPA	306
18-0785	JUNTA MONTAJE CARBURADOR	305
18-0786	JUNTA CAMARA DE FLOTADOR	305
18-0791	JUNTA TAPA CAMBIO	90
18-0792	JUNTA TERMOSTATO	341
18-0793	JUNTA TERMOSTATO	341
18-0794	JUNTA TERMOSTATO	341
18-0795	JUNTA TERMOSTATO	341
18-0796	JUNTA TERMOSTATO	341
18-0797	JUNTA TERMOSTATO	341
18-0798	JUNTA TAPA ESCAPE	306
18-0799	JUNTA TAPA ESCAPE	306
18-0807-1	JUNTA	305
18-0808	JUNTA VÁLVULA PRESIÓN	306
18-0809	JUNTA	305
18-0812	JUNTA TAPA ESCAPE	306
18-0813	JUNTA BASE	306
18-0815	JUNTA	306
18-0823	JUNTA TAPA ESCAPE	306
18-0826	JUNTA TORNILLO DRENAJE	308
18-0829	JUNTA TAPA	306

Referencia	Descripción	Página
18-0835	JUNTA TERMOSTATO	91, 306
18-0836	JUNTA TERMOSTATO	306
18-0840	JUNTA CAMARA DE FLOTADOR	305
18-0844	JUNTA TERMOSTATO	306
18-0847	JUNTA TAPA ESCAPE	306
18-0849	JUNTA MONTAJE BOMBA COMBUSTIBLE	299
18-0850	JUNTA BOMBA COMBUSTIBLE	195
18-0851	JUNTA	199
18-0856	JUNTA	299
18-0870	JUNTA TAPA	89
18-0871	VÁLVULA DE SERVICIO CON ARO TÓRICO	153
18-0879	JUNTA BASE	90
18-0882	JUNTA VARILLA	199
18-0892	MANGUERA	198
18-0904	JUNTA BASE	90
18-0912	JUNTA PLATINA ALOJAMIENTO EJE	90
18-0914	JUNTA TERMOSTATO	91
18-0917	JUNTA MOTOR TILT	200
18-0918	JUNTA TAPA ESCAPE	88
18-0922	JUNTA PLATINA	89
18-0926	JUNTA TAPA	89
18-0927	JUNTA TAPA ESCAPE	196
18-0929	JUNTA TERMOSTATO	198
18-0932	JUNTA TAPA	89
18-0933	JUNTA	195
18-0934	JUNTA BASE BLOQUE	91
18-0935	JUNTA BASE	195
18-0936	JUNTA PLATINA VÁLVULA	91
18-0940	JUNTA PLATINA	89
18-0941	JUNTA	198
18-0942	JUNTA PLATINA	89
18-0944	JUNTA PLATINA	89
18-0946	JUNTA TAPA	89
18-0949	JUNTA TAPA	200
18-0952	JUNTA PLATINA VÁLVULA	91
18-0953	JUNTA	199
18-0955	JUNTA TAPA ESCAPE	196
18-0957	JUNTA BASE MOTOR	197
18-0959	JUNTA PLATINA	195
18-0961	JUNTA MONTAJE CARBURADOR	194
18-0963	JUNTA COLECTOR DOBLE	195
18-0965	JUNTA	197
18-0967	JUNTA	198
18-0968	JUNTA BASE BLOQUE	91
18-0969	JUNTA ALOJAMIENTO IMPULSOR	199
18-0970	BASE BOMBA COMBUSTIBLE	88
18-0971	JUNTA	198
18-0973	JUNTA CARBURADOR	196
18-0975	JUNTA CARBURADOR	195
18-0977	JUNTA TERMOSTATO	198
18-0978	JUNTA A TAPA	195
18-0979	JUNTA SILENCIADOR	195
18-0981	JUNTA PLATINA	196
18-0982-1	JUNTA PLATINA BLOQUE	91
18-0983	JUNTA	195
18-0985	JUNTA SILENCIADOR	195
18-0987	JUNTA CUERPO DE ACELERACIÓN	196
18-0989	JUNTA SILENCIADOR	195
18-0991	JUNTA PLATINA	196
18-0993	JUNTA Y TAPA	153
18-0995	JUNTA BASE MOTOR	197
18-0999-9	JUNTA ESCAPE	196
18-1111	COJINETE ENGRANAJE REVERSO	102
18-1112	COJINETE DE EMPUJE ENGRANAJE REVERSO	102

Referencia	Descripción	Página
18-1113	COJINETE ENGRANAJE REVERSO	102
18-1115	COJINETE PIÑÓN AVANTE INT.	102
18-1117	COJINETE PIÑÓN	102, 215
18-1118	COJINETE PIÑÓN	102
18-1122	COJINETE INTERIOR ENGRANAJE AVANTE	102
18-1126	COJINETE RODILLO	103
18-1143	COJINETE CÓNICO	102
18-1151	COJINETE ROTOR	26
18-1152	COJINETE ROTOR	26
18-1153	COJINETE A BOLAS	73, 102
18-1154	COJINETE BOLA	73, 102, 215
18-1155	COJINETE A BOLAS	102
18-1156	COJINETE RODILLO	102, 365
18-1157	COJINETE AGUJAS	102, 365
18-1158	COJINETE AGUJAS	102, 216, 365
18-1159	COJINETE RODILLO	102
18-1161	COJINETE AGUJAS	216
18-1162	COJINETE RODILLO	102
18-1163	COJINETE RODILLO	103
18-1164	COJINETE RODILLO	103
18-1166	COJINETE RODILLO	103
18-1170	COJINETE PIÑÓN INFERIOR	103
18-1186	COJINETE AGUAS CON RETENEDORES	73
18-1190	COJINETE A BOLAS	102
18-1191	ARANDELA EMPUJE	102
18-1194		73
18-1196	COJINETE	73
18-1197	COJINETE CÓNICO	102
18-1202	JUNTA TERMOSTATO	198
18-1205	JUNTA	197
18-1207	JUNTA COLECTOR ESCAPE	196
18-1212	JUNTA COLECTOR	196
18-1218	JUNTA TAPA ESCAPE	196
18-1219	CASQUILLO	174
18-1219	CASQUILLO	200
18-1221	TAPA VÁLVULA	174, 200
18-1222	JUNTA TERMOSTATO	174, 199
18-1224	JUNTA TAPA ESCAPE	196
18-1236	TORNILLO DRENAJE	212
18-1241	JUNTA TAZA FLOTADOR Y AGUJA	194
18-1243	MUELLE VÁLVULA	174
18-1282	CABLE Y CLIP HOMBRE AL AGUA	144
18-1283	JUNTA ADMISIÓN	197
18-1284	JUNTA ADMISIÓN	197
18-1285	JUNTA ENTRADA BABOR	197
18-1286	RETÉN SUPERIOR	185
18-1287	ENGRANAJE Y CASQUILLO	220
18-1288	ENGRANAJE PIÑÓN	220
18-1289	EMBRAGUE	221
18-1289	ENGRANAJE REVERSO	221
18-1291	JUEGO DE ENGRANAJES	220
18-1292	JUEGO DE ENGRANAJES	220
18-1293	JUEGO DE ENGRANAJES	220
18-1296	COJINETE DE AGUJAS	182
18-1299	COJINETE	216
18-1343	COJINETE RETENEDOR	221
18-1344	COJINETE AGUJAS	216
18-1345	COJINETE BOLA	73
18-1347	COJINETE PRINCIPAL	102
18-1350	COJINETE AGUJAS	216
18-1351	COJINETE AGUJAS	216
18-1352	COJINETE CENTRAL	181
18-1353	COJINETE CENTRAL	181
18-1354	COJINETE AGUJAS	216

Referencia	Descripción	Página
18-1355	COJINETE AGUJAS	216
18-1356	COJINETE AGUJAS	216
18-1357	COJINETE AGUJAS	216
18-1360	COJINETE BIELA	181
18-1361	COJINETE BIELA	182
18-1363	COJINETE EMPUJE	216
18-1364	COJINETE EMPUJE	216
18-1365	COJINETE EMPUJE	216
18-1366	COJINETE EMPUJE	216
18-1367	COJINETE EMPUJE	216
18-1368	COJINETE EMPUJE	216
18-1369	COJINETE EMPUJE	216
18-1370	COJINETE EMPUJE	216
18-1371	COJINETE EMPUJE	216
18-1374	COJINETE DE AGUJAS	182
18-1376	COJINETE DE AGUJAS	182
18-1376	COJINETE BIELA	182
18-1377	COJINETE CENTRAL PRINCIPAL	182
18-1386	JUEGO COJINETES	182
18-1389	JUEGO COJINETES	182
18-1410	COJINETE	293
18-1411	COJINETE	293
18-1412	COJINETE	342
18-1414	COJINETE	342
18-1415	COJINETE	342
18-1416	COJINETE	342
18-1417	COJINETE	342
18-1459	JUNTA BOMBA AGUA	341
18-1500	REJILLA ADMISIÓN	221
18-1505	ENGRANAJES	201
18-1506	TERMOSTATO	175
18-15061	MOTOR ARRANQUE FUERABORDA	356
18-1507	RETÉN TERMOSTATO	175
18-15128	CORREAS	39
18-15129	CORREAS	39
18-15146	CORREAS	78
18-15147	CORREAS	78
18-15148	CORREAS	78
18-15149	CORREAS	78
18-15150	CORREAS	78
18-1522	RELÉ	258
18-1523	RELÉ	258
18-1524	RELÉ	258
18-1525	RELÉ	258
18-1550	KIT COMPLETO DE ENGRANAJES	106
18-1551	KIT COMPLETO DE ENGRANAJES	106
18-1560	REVERSO ENGRANAJE	106
18-1564	KIT ENGRANAJE	106
18-1565	SELECTOR	107
18-1566	ENGRANAJE REVERSO	107
18-1704	TORNILLO	201
18-1712	RETENEDOR	221
18-1721	EJE TRANSMISIÓN	218
18-1722	EJE TRANSMISIÓN	218
18-1723	EJE INFERIOR	218
18-1730	ACOPLAMIENTO	60
18-1732	EJE INFERIOR	218
18-1734	RETÉN TERMOSTATO	175
18-1736	EJE	106
18-1737	EJE	106
18-1750	ALOJAMIENTO	216
18-1752	BIELA	181
18-1753	BIELA	181, 306
18-1755	BIELA	293
18-1755K	KIT BIELA	293

Referencia	Descripción	Página
18-1756	BIELA	293
18-1757	BIELA	342
18-1757K	KIT CONEXIÓN	342
18-1758	BIELA	342
18-1759	BIELA	342
18-1759K	KIT CONEXIÓN	342
18-18000	CORREAS	39
18-18100	CORREAS	39
18-1828	RETÉN	275
18-1829	RETÉN	275
18-1830	DAMPER RETÉN AGUA	275
18-18303	MOTOR POWER TRIM	335
18-18304	MOTOR POWER TRIM	335
18-1831	DAMPER RETÉN AGUA	275
18-1832	DAMPER RETÉN AGUA	275
18-1833	DAMPER RETÉN	277
18-1834	DAMPER RETÉN AGUA	277
18-1836	RETÉN	275
18-1837	RETÉN	275
18-1838	RETÉN CORTO	60
18-1839	RETÉN LARGO	60
18-1840	RETÉN	275
18-2002	RETENES ACEITE	367
18-2053	RETENES ACEITE	367
18-2054	RETENES ACEITE	367
18-2081	RETENES TRIM	258
18-2082	RETENES TRIM	258
18-2083	RETÉN INYECTOR COMB.	258
18-2083	RETÉN INYECTOR COMB.	269
18-2093	RETÉN	218
18-2143	KIT SILENT BLOCK	78
18-2144	KIT SILENT BLOCK	78
18-2155	CASQUILLO CAMBIO	105
18-2187	EJE HÉLICE	219
18-2207	JUEGO DE ENGRANAJES REVERSO	220
18-2208	ENGRANAJE REVERSO	220
18-2209	TRINQUETE DESLIZANTE	220
18-2210	JUEGO DE ENGRANAJES	220
18-2216	TRINQUETE DESLIZANTE	220
18-2217	JUEGO DE ENGRANAJES	220
18-2218	JUEGO DE ENGRANAJES AVANCE	220
18-2219	ENGRANAJE REVERSO	220
18-2220	EMBRAGUE	220
18-2221	JUEGO DE ENGRANAJES	220
18-2236	SELECTOR CAMBIO	106
18-2239	EJE TRANSMISIÓN	106
18-2243	BOLA DE RETENCIÓN	222
18-2244	TAPÓN DRENAJE	105
18-2250	EJE HÉLICE	219
18-2251	EJE HÉLICE	219
18-2252	EJE HÉLICE	219
18-2254	EJE TRANSMISIÓN	106
18-2260	EJE TRANSMISIÓN	106
18-2277	EJE INFERIOR	218
18-2279	EJE INFERIOR	218
18-2287	EMBRAGUE	221
18-2288	EJE HÉLICE	219
18-2290	JUEGO DE ENGRANAJE	221
18-2298	ARANDELA CIERRE	108
18-2299	ARANDELA CIERRE	108
18-2308	EMBRAGUE	221
18-2309	ENGRANAJE REVERSO	221
18-2310	JUEGO DE ENGRANAJES AVANCE	221
18-2315	JUEGO DE ENGRANAJE	221
18-23205	BOBINA ENCENDIDO	25

Referencia	Descripción	Página
18-2325	EJE SUPERIOR	218
18-23251	BOBINA ENCENDIDO	355
18-2326	EJE SUPERIOR	218
18-2327	EJE SUPERIOR	218
18-2328	EJE SUPERIOR	218
18-2330	EJE SUPERIOR	218
18-2355	EJE HÉLICE	219
18-2359	JUEGO TUERCAS EJE TRANSMISIÓN	106
18-2370	RODILLO DIÁBOLO	103
18-2371	TORNILLO DRENAJE	308
18-2374	TORNILLO DRENAJE MAGNÉTICO	308
18-2375	TAPÓN DRENAJE	105
18-2377	TORNILLO DE DRENAJE	212
18-2378	TORNILLO DRENAJE MAGNÉTICO	212
18-2379	TORNILLO UNIDAD INFERIOR	212
18-2385	EJE HÉLICE	308
18-2387	TORNILLO	212
18-2388	EJE HÉLICE	308
18-2389	CASQUILLO	200
18-2391	CASQUILLO	175
18-2391	CASQUILLO	200
18-2392	CASQUILLO	200
18-2398	MUELLE TRINQUETE	222
18-2399	MUELLE TRINQUETE	222
18-2430	JUNTA	93
18-2448	KIT INFERIOR DE LLENADO Y VACIADO	308
18-2448	KIT DRENAJE/LLENADO UNIDAD INFERIOR	366
18-2448	LLENADO UNIDAD INF./KIT DE DRENAJE	378
18-2456	TORNILLO DRENAJE	294
18-2470	JUNTA MONTAJE CARBURADOR	364
18-2471	JUNTA MONTAJE CARBURADOR	364
18-2472	JUNTA MONTAJE CARBURADOR	364
18-2473	JUNTA MONTAJE CARBURADOR	364
18-2480	CONJUNTO JUNTAS	364
18-2481	CONJUNTO JUNTAS	364
18-2482	CONJUNTO JUNTAS	364
18-2495	JUNTA BOMBA AGUA	362
18-2496	JUNTA BOMBA AGUA	362
18-2499	JUNTA BOMBA AGUA	362
18-2500	JUNTA TAPA ESCAPE	89
18-2501	JUNTA ALOJAMIENTO	88
18-2502	JUNTA PLATINA	89
18-2503	JUNTA PLATINA ESCAPE	91
18-2504	JUNTA TAPA BLOQUE	89
18-2505	JUNTA TAPA	89
18-2506	JUNTA PLATINA ESCAPE	91
18-2507	JUNTA TAPA	89
18-2508	JUNTA PLATINA ESCAPE	91
18-2509	JUNTA CARBURADOR	87
18-2510	JUNTA ALOJAMIENTO	88
18-2511	JUNTA PLATINA ESCAPE A ALOJAMIENTO	91
18-25200	ARBOL DE LEVAS SENSOR	359
18-25201	SENSOR	359
18-2524	JUNTA BOMBA AGUA	364
18-25300	CAJA CDI	250
18-2532	RETÉN TAPA	200
18-2534	RETÉN	200
18-2536	RETÉN ALOJAMIENTO IMPULSOR	199
18-2537	RETÉN GOMA	200
18-2539	RETÉN GOMA	199
18-25400	BOBINA	25
18-2543	JUNTA	198
18-2544	JUNTA	198
18-2545	JUNTA PLATINA ESCAPE	196

Referencia	Descripción	Página
18-2546	JUNTA TERMOSTATO	199
18-2547	JUNTA PASO DE AGUA	199
18-2548	JUNTA TERMOSTATO	199
18-2549	JUNTA TAPA ESCAPE	196
18-2550	JUNTA BASE MOTOR	197
18-25513	BOBINA	26
18-2557	JUNTA IMPULSOR	199
18-2558	JUNTA IMPULSOR	91
18-2559	JUNTA IMPULSOR	91
18-2560	JUNTA IMPULSOR	93
18-25604	BOBINA LUZ	250
18-2561	JUNTA IMPULSOR	91
18-2562	JUNTA IMPULSOR	92
18-2563	JUNTA IMPULSOR	92, 364
18-2564	JUNTA IMPULSOR	92, 364
18-2565	JUNTA IMPULSOR	92, 364
18-25650	BOBINA PULSADOR	250
18-25652	BOBINA PULSADOR	250
18-2566	JUNTA IMPULSOR	92
18-2568	JUNTA TAPA	88
18-2569	JUNTA TAPA FILTRO	88
18-2570	JUNTA TAPA	88
18-2571	JUNTA CARBURADOR	87
18-2572	JUNTA CARBURADOR	87
18-2573	JUNTA TAPA	89
18-2574	JUNTA TAPA ESCAPE	89
18-2575	JUNTA CARBURADOR	88
18-2579	JUNTA FLOTADOR	194
18-2582	JUNTA CARBURADOR	194
18-2592	JUNTA FLOTADOR	305
18-2593	JUNTA BOMBA DE AGUA	92
18-2595	JUEGO DE JUNTAS	231
18-2599	RETÉN/HERRAMIENTA	111
18-2605	TORNILLOS	274
18-2606	TORNILLOS	274
18-2607	TORNILLOS	274
18-2608	JUNTA BOMBA AGUA	364
18-2609	JUNTA BOMBA AGUA	364
18-2610	JUNTA	90
18-2611	JUNTA	90
18-2621	JUNTA PLATINA	88
18-2623	KIT RETENES UNIDAD INFERIOR	228
18-2624	KIT REETENES PARTE INFERIOR	113
18-2626	KIT REETENES PARTE INFERIOR	113
18-2627	KIT REETENES PARTE INFERIOR	113
18-2628	KIT REETENES PARTE INFERIOR	113
18-2629	KIT REETENES PARTE INFERIOR	114
18-2635	KIT REETENES PARTE INFERIOR	114
18-2642	KIT REETENES PARTE INFERIOR	114
18-2646-1	KIT REETENES CAJA DE ENGRANAJE	114
18-2653	KIT REETENES CAJA DE ENGRANAJE	115
18-2654	KIT REETENES CAJA DE ENGRANAJE	115
18-2655	KIT REETENES CAJA DE ENGRANAJE	115
18-2656	KIT RETENES UNIDAD INFERIOR	228
18-2657	KIT RETENES UNIDAD INFERIOR	228
18-2658	KIT RETENES UNIDAD INFERIOR	228
18-2659	KIT RETENES UNIDAD INFERIOR	228
18-2660	KIT RETENES UNIDAD INFERIOR	228
18-2679	KIT RETENES UNIDAD INFERIOR	228
18-2680	KIT RETENES UNIDAD INFERIOR	229
18-2681	KIT RETENES UNIDAD INFERIOR	229
18-2682	KIT RETENES UNIDAD INFERIOR	229
18-2683	KIT RETENES UNIDAD INFERIOR	229
18-2684	KIT RETENES UNIDAD INFERIOR	229
18-2685	KIT RETENES UNIDAD INFERIOR	229

Referencia	Descripción	Página
18-2686	KIT RETENES UNIDAD INFERIOR	230
18-2687	KIT RETENES UNIDAD INFERIOR	230
18-2688	KIT RETENES UNIDAD INFERIOR	230
18-2689	KIT RETENES UNIDAD INFERIOR	230
18-2690	KIT RETENES UNIDAD INFERIOR	230
18-2691	KIT RETENES UNIDAD INFERIOR	230
18-2692	KIT RETENES UNIDAD INFERIOR	230
18-2694	KIT RETENES UNIDAD INFERIOR	230
18-2697-1	KIT REETENES PARTE INFERIOR	115
18-2703	CASQUILLO	200
18-2704	CASQUILLO	200
18-2705	RETÉN ACEITE	200
18-2706	CASQUILLO	200
18-2708	CASQUILLO	200
18-2709	JUNTA PLATINA DESGASTE	199
18-2710	JUNTA	88
18-2712	JUNTA PLATINA	88
18-2713	JUNTA ALOJAMIENTO	90
18-2714	JUNTA TAPA ESCAPE	90
18-2716	JUNTA TAPA ESCAPE	90
18-2717	JUNTA COLECTOR ESCAPE	90
18-2721	JUNTA TERMOSTATO	88
18-2725	KIT RETENES UNIDAD INFERIOR	116
18-2728	RETÉN TUBO AGUA	93
18-2729	JUNTA TERMOSTATO	88
18-2731	OJAL	94
18-2735	JUNTA PLATINA	90
18-2736	JUNTA CULATA	85
18-2737	JUNTA BLOQUE	87
18-2739	JUNTA PLATINA	90
18-2740	JUNTA TAPA	89
18-2741	JUNTA TAPA ESCAPE	90
18-2742	MANGUITO FUELLE	111
18-2749	JUNTA TERMOSTATO	88
18-2769	RETÉN GOMA	200
18-2773	ALOJAMIENTO COJINETE	308
18-2782	ALOJAMIENTO COJINETE	308
18-2785	KIT RETENES PARTE INFERIOR	116
18-2785	KIT RETÉN ALOJAMIENTO ENGRANAJE	323
18-2787	KIT RETÉN ALOJAMIENTO ENGRANAJE	116, 323
18-2788	KIT RETÉN UNIDAD INFERIOR	324
18-2789	KIT RETÉN UNIDAD INFERIOR	324
18-2792	KIT RETÉN UNIDAD INFERIOR	324
18-2794-1	KIT RETÉN UNIDAD INFERIOR	324
18-2798	KIT RETÉN UNIDAD INFERIOR	324
18-2799	KIT RETÉN UNIDAD INFERIOR	324
18-2800	JUNTA CARBURADOR	87
18-2801	JUNTA BOMBA AGUA	92
18-2802	JUNTA CARBURADOR	87
18-2803	JUNTA CARBURADOR	87
18-2804	JUNTA CARBURADOR	87
18-2805	JUNTA TAPA	89
18-2806	JUNTA TAPA	89
18-2807	JUNTA TAPA	89
18-2808	JUNTA TAPA	89
18-28080	JUEGO DE CABLES	30
18-28081	JUEGO DE CABLES	30
18-28082	JUEGO DE CABLES	30
18-28083	CABLE BUJÍA	30
18-28084	JUEGO DE CABLES BUJÍA	30
18-28085	JUEGO DE CABLES BUJÍA	30
18-28086	JUEGO DE CABLES BUJÍA	30
18-2809	JUNTA TAPA	91
18-2810	JUNTA TAPA	90
18-2823	JUNTA BOMBA DE AGUA INFERIOR	92

Referencia	Descripción	Página
18-2824	JUNTA BOMBA DE AGUA SUPERIOR	92
18-2825	JUNTA BASE BOMBA DE AGUA	92
18-2826	JUNTA BASE BOMBA DE AGUA	92
18-2827	JUNTA BOMBA DE AGUA SUPERIOR	92
18-2828	JUNTA BOMBA DE AGUA INFERIOR	92
18-2835	JUNTA BASE BLOQUE	91
18-2836	JUNTA TAPA ESCAPE	89
18-2837	JUNTA TAPA	90
18-2838	JUNTA TAPA	89
18-2839	JUNTA TAPA ESCAPE	89
18-2841	JUNTA BASE BOMBA DE AGUA	92
18-2852	JUNTA BASE MOTOR	197
18-2853	JUNTA TAPA ESCAPE	196
18-2855	JUNTA TAPA	199
18-2856	JUNTA	198
18-2857	JUNTA SILENCIADOR	195
18-2862	JUNTA PLATINA	196
18-2864	JUNTA BASE MOTOR	197
18-2865	JUNTA BASE MOTOR	197
18-2866	JUNTA TAPA ESCAPE	196
18-2867	JUNTA COLECTOR	196
18-2868	JUNTA BASE MOTOR	197
18-2869	JUNTA ALOJAMIENTO ESCAPE	200
18-2870	JUNTA TAPA ESCAPE	196
18-2871	JUNTA TAPA ESCAPE	196
18-2872	JUNTA CILINDRO BABOR	198
18-2873	JUNTA	198
18-2874	JUNTA TAPA SOLENOIDE	199
18-2876	BYPASS COVER GASKET	198
18-2877	JUNTA	197
18-2878	JUNTA	197
18-2879	JUNTA BOMBA COMBUSTIBLE	195
18-2880	JUNTA TPA PLATINA	199
18-2881	JUNTA ALOJAMIENTO	201
18-2884	JUNTA CULATA	191
18-2885	JUNTA CULATA	191
18-2886	JUNTA TAPA ESCAPE	196
18-2887	JUNTA TANQ. COMB.	201
18-2888	JUNTA CULATA	191
18-2889	JUNTA FILTRO	195
18-2890	JUNTA FLOTADOR	194
18-2891	JUNTA ALOJAMIENTO COJINETE	200
18-2892	JUNTA FILTRO	195
18-2893	JUNTA FLOTADOR	194
18-2894	JUNTA ALOJAMIENTO ESCAPE	197
18-2898	JUNTA ALOJAMIENTO ESCAPE	197
18-2900	JUNTA BOMBA COMBUSTIBLE	195
18-2901	JUNTA ALOJAMIENTO ESCAPE	197
18-2903	JUNTA FLOTADOR	194
18-2904	JUNTA PLATINA ESCAPE	198
18-2905	JUNTA TAPA AGUA	198
18-2906	JUNTA FLOTADOR	194
18-2907	JUNTA ALOJAMIENTO ESCAPE	198
18-2908	JUNTA FLOTADOR	194
18-2913	JUNTA TAPA ESCAPE	197
18-2914	JUNTA BOMBA DE AGUA	93
18-2915	JUNTA BOMBA DE AGUA	93
18-2919	JUNTA BOMBA DE AGUA	93
18-2938	JUNTA TAPA ESCAPE	197
18-2943	JUNTA TAPA	89
18-2945	RETÉN DRENAJE	93, 212, 364
18-2948	ARANDELA GOMA	93
18-2950	JUNTA CULATA	191
18-2951	JUNTA CULATA	191
18-2952	JUNTA CULATA	191

Referencia	Descripción	Página
18-2954	JUNTA CULATA	191
18-2956	JUNTA CULATA	191
18-2957	JUNTA CULATA	191
18-2958	JUNTA CULATA	191
18-2959	JUNTA CULATA	191
18-2960	JUNTA CULATA	191
18-2961	JUNTA CULATA	191
18-2962	JUNTA CULATA	191
18-2963	JUNTA CULATA	191
18-2964	JUNTA CULATA	192
18-3000	IMPULSOR	339
18-3001	IMPULSOR	162
18-3002	IMPULSOR	162
18-3003	IMPULSOR	162
18-3006	IMPULSOR	162
18-3008	IMPULSOR	59
18-3012	IMPULSOR	59
18-3013	RETÉN BOMBA DE AGUA	60
18-3014	RETÉN BOMBA DE AGUA	60
18-30155	IMPULSOR	162
18-3017	IMPULSOR	59
18-3023	IMPULSOR	339
18-3031	IMPULSOR	360
18-3035	IMPULSOR	339
18-3040	IMPULSOR	272
18-3042	IMPULSOR	272
18-3043	IMPULSOR	162
18-3044	IMPULSOR	162
18-3049	IMPULSOR	339
18-3050	IMPULSOR	162
18-3051	IMPULSOR	162
18-3052	IMPULSOR	59
18-3053-1	IMPULSOR	163
18-3055	IMPULSOR	163
18-3056	IMPULSOR	59
18-3056	IMPULSOR	360
18-3057	IMPULSOR	59
18-3059	IMPULSOR	163
18-3062	IMPULSOR	59
18-3063	IMPULSOR	59, 272
18-3065	IMPULSOR	272
18-3066	IMPULSOR	59, 272
18-3067	IMPULSOR	59, 272
18-3068	IMPULSOR	272
18-3069	IMPULSOR	59, 272
18-3070	IMPULSOR	272
18-3071	IMPULSOR	272
18-3072	IMPULSOR	59, 272
18-3073	IMPULSOR	60, 272
18-3074	IMPULSOR	60, 272
18-3082	IMPULSOR	163
18-3083	IMPULSOR	163
18-3088	IMPULSOR	272
18-3090	IMPULSOR	163
18-3091	IMPULSOR	163
18-3092	IMPULSOR	339
18-3094	IMPULSOR	59, 339
18-3095	IMPULSOR	339
18-3096	IMPULSOR	163, 339
18-3097	IMPULSOR	339
18-3098	IMPULSOR	60
18-3099	IMPULSOR	163, 339
18-3100	IMPULSOR	360
18-3102	IMPULSOR PLATINA	163
18-3103	IMPULSOR PLATINA	163

Referencia	Descripción	Página
18-3104-1	IMPULSOR	163
18-3107	PLATINA IMPULSOR	60
18-3109	TUBO GUÍA	60
18-3110	CASQUILLO	60
18-3113	ALOJAMIENTO	60
18-3114	ALOJAMIENTO	60
18-3115	ALOJAMIENTO	60
18-3116	ALOJAMIENTO BOMBA	60
18-3117	PLATINA IMPULSOR	60
18-3118	ALOJAMIENTO BOMBA	60
18-3122	PLATINA IMPULSOR	60, 361
18-3126	PLATINA DESGASTE	164
18-3127	IMPULSOR PLATINA	163
18-3129	BOMBA DE AGUA ALOJAMIENTO	164
18-3133	TORNILLO ACERO INOXIDABLE	194
18-3135	TORNILLO ACERO INOXIDABLE	194
18-3136	TORNILLO ACERO INOXIDABLE	194
18-3139	PLATINA IMPULSOR	60
18-3142	PLATINA IMPULSOR	274
18-3143	PLATINA IMPULSOR	274
18-3148	KIT REPARACIÓN BOMBA DE AGUA	64, 277
18-3149-1	KIT BOMBA DE AGUA	61
18-3151	ALOJAMIENTO	60
18-3153	TORNILLO ACERO INOXIDABLE	194
18-3154	ALOJAMIENTO	60
18-3162	ALOJAMIENTO IMPULSOR	272
18-3163	PLATINA IMPULSOR	274
18-3164	ALOJAMIENTO IMPULSOR	272
18-3166	DAMPER RETÉN AGUA	277
18-3170	BOMBA AGUA ALOJAMIENTO	273
18-3171	BOMBA AGUA ALOJAMIENTO	273
18-3173-1	BOMBA AGUA ALOJAMIENTO	273
18-3176	DAMPER RETÉN AGUA	277
18-3178	PLATINA DESGASTE	164
18-3179	CASQUILLO BOMBA DE AGUA	164
18-3180	BOMBA DE AGUA ALOJAMIENTO	164
18-3182	IMPULSOR PLATINA	164
18-3185	BOMBA AGUA ALOJAMIENTO	273
18-3186	PLATINA IMPULSOR	274
18-3187	KIT SEPARACIÓN IMPULSOR	361
18-3188	PLATINA IMPULSOR	339
18-3189	PLATINA IMPULSOR	339
18-3190	PLATINA IMPULSOR	340
18-3191	PLATINA IMPULSOR	340
18-3192	PLATINA IMPULSOR	340
18-3193	PLATINA IMPULSOR	340
18-3194	PLATINA IMPULSOR	274
18-3195	PLATINA IMPULSOR	274
18-3196	PLATINA IMPULSOR	275
18-3200	ARANDELA BLOQUEO	109
18-3200	ARANDELA SUJECIÓN	367
18-3201	KIT REPARACIÓN IMPULSOR	165
18-3202	KIT REPARACIÓN IMPULSOR	165
18-3203	KIT REPARACIÓN IMPULSOR	165
18-3204	ARANDELA BLOQUEO	109
18-3207	KIT REPARACIÓN IMPULSOR	61
18-3210	KIT REPARACIÓN IMPULSOR	165
18-3211	KIT REPARACIÓN IMPULSOR	165
18-3214	KIT REPARACIÓN IMPULSOR	61
18-3214	KIT BOMBA AGUA	361
18-3215	KIT REPARACIÓN IMPULSOR	61
18-32153	SENSOR OXÍGENO	359
18-32154	SENSOR OXÍGENO	336
18-3217	KIT IMPULSOR	62
18-3227	CLAVIJA BASE BOMBA DE AGUA	60

Referencia	Descripción	Página
18-3239	KIT REPARACIÓN IMPULSOR	62
18-3242	KIT REPARACIÓN IMPULSOR	340
18-3243	KIT REPARACIÓN IMPULSOR	340
18-3244	KIT REPARACIÓN IMPULSOR	340
18-3245	IMPULSOR	360
18-32455	IMPULSOR	360
18-3246	IMPULSOR	360
18-3247	IMPULSOR	360
18-3248	IMPULSOR	360
18-3249	IMPULSOR	360
18-3250	IMPULSOR	360
18-3252	KIT REPARACIÓN IMPULSOR	62
18-3253	KIT BOMBA AGUA	340
18-3254	KIT BOMBA AGUA	340
18-3255	KIT BOMBA AGUA	340
18-3256	KIT BOMBA AGUA	340
18-3257	KIT BOMBA AGUA	340
18-3258	KIT BOMBA AGUA	340
18-3259	KIT BOMBA AGUA	340
18-3260	KIT BOMBA AGUA	340
18-3264	KIT REPARACIÓN BOMBA AGUA	340
18-3265	KIT REPARACIÓN IMPULSOR	62
18-3266	KIT REPARACIÓN BOMBA AGUA	341
18-3267	KIT BOMBA AGUA	341
18-3268	LLAVE IMPULSOR	360
18-3269	LLAVE IMPULSOR	360
18-3270	LLAVE IMPULSOR	360
18-3271	LLAVE IMPULSOR	360
18-3273	LLAVE IMPULSOR	361
18-3278	KIT SERVICIO BOMBA AGUA	361
18-3279	KIT SERVICIO BOMBA AGUA	361
18-3280	KIT SERVICIO BOMBA AGUA	361
18-3281	KIT SERVICIO BOMBA AGUA	361
18-3282	KIT SERVICIO BOMBA AGUA	361
18-3283	KIT SERVICIO BOMBA AGUA	361
18-3284	KIT SERVICIO BOMBA AGUA	361
18-3285	KIT SERVICIO BOMBA AGUA	361
18-3288	RETÉN	365
18-3290	CODO INDICADOR	160
18-3291	LLAVE IMPULSOR	339
18-3292	LLAVE IMPULSOR	339
18-3293	CHAVETA	60
18-3296	LLAVE IMPULSOR	339
18-3297	LLAVE IMPULSORA	274
18-3300	CHAVETA	60
18-3300	LLAVE IMPULSORA	274
18-3301	LLAVE IMPULSORA	274
18-3302	LLAVE IMPULSORA	274
18-3305	CHAVETA	60
18-3305	LLAVE IMPULSORA	274
18-3310	KIT BOMBA AGUA	279
18-3311	KIT BOMBA AGUA	279
18-3312	KIT BOMBA AGUA	279
18-3313-1	KIT BOMBA AGUA	279
18-3314	KIT BOMBA DE AGUA	63
18-3315-2	KIT BOMBA AGUA	169
18-3316	KIT BOMBA DE AGUA	63
18-3319	KIT BOMBA DE AGUA	63
18-3322	KIT BOMBA DE AGUA	63
18-3323	KIT BOMBA DE AGUA	64
18-3324	KIT BOMBA DE AGUA	64
18-3325	KIT BOMBA AGUA	165
18-3327	KIT BOMBA AGUA	165
18-3328	ALOJAMIENTO IMPULSOR	273
18-3329	CASQUILLO	200

Referencia	Descripción	Página
18-3332	CASQUILLO	200
18-3333	ALOJAMIENTO IMPULSOR	273
18-3336	BOMBA DE AGUA ALOJAMIENTO	164
18-3337	CASQUILLO	200
18-3343	PLATINA DESGASTE	164
18-3344	PLATINA IMPULSOR	274
18-3345	PLATINA IMPULSOR	274
18-3346	ALOJAMIENTO Y PLATINA IMPULSOR	164
18-3356	BOMBA AGUA ALOJAMIENTO	273
18-3357	PLATINA IMPULSOR	274
18-3358	CASQUILLO BOMBA DE AGUA	164
18-3359	IMPULSOR PLATINA	164
18-3360	JUNTA ALOJAMIENTO IMPULSOR	198
18-3363	BOMBA DE AGUA ALOJAMIENTO	164
18-3365	TORNILLO ACERO INOXIDABLE	194
18-3366	IMPULSOR	163
18-3367	BOMBA DE AGUA ALOJAMIENTO	164
18-3368	IMPULSOR	163
18-3369	TORNILLO ACERO INOXIDABLE	194
18-3370	KIT BOMBA AGUA	279
18-3371	KIT BOMBA AGUA	279
18-3372	KIT BOMBA AGUA	279
18-3373	KIT BOMBA AGUA	279
18-3374	KIT BOMBA AGUA	280
18-3376	KIT BOMBA AGUA	166
18-3377	KIT BOMBA AGUA	166
18-3378	KIT BOMBA AGUA	166
18-3379	KIT BOMBA AGUA	166
18-3380	KIT BOMBA AGUA	166
18-3381	KIT BOMBA AGUA	166
18-3382	KIT BOMBA AGUA	166
18-3383	KIT BOMBA AGUA	167
18-3384	KIT BOMBA AGUA	167
18-3385	KIT BOMBA AGUA	167
18-3387	KIT BOMBA AGUA	167
18-3388	KIT BOMBA AGUA	167
18-3389	KIT BOMBA COMBUSTIBLE	167
18-3390	KIT BOMBA AGUA	168
18-3391	KIT BOMBA AGUA	168
18-3392	KIT BOMBA AGUA	168
18-3393	KIT BOMBA AGUA	168
18-3394	KIT BOMBA AGUA	168
18-3395	KIT BOMBA AGUA	280
18-3396-1	KIT BOMBA AGUA	280
18-3397	KIT BOMBA DE AGUA	277
18-3398	KIT BOMBA AGUA	280
18-3399	KIT BOMBA AGUA	168
18-3400	KIT BOMBA AGUA	169
18-3401	KIT BOMBA AGUA	169
18-3402	KIT BOMBA AGUA	169
18-3403	KIT BOMBA AGUA	169
18-3404	LLAVE IMPULSOR	339
18-3405	BOMBA DE AGUA ALOJAMIENTO	164
18-3406	KIT REPARACIÓN BOMBA DE AGUA	62
18-3407	KIT REPARACIÓN BOMBA DE AGUA	62
18-3408	KIT BOMBA DE AGUA CON ALOJAMIENTO	277
18-3409	KIT BOMBA DE AGUA CON ALOJAMIENTO	277
18-3410	KIT BOMBA DE AGUA CON ALOJAMIENTO	277
18-3411	KIT BOMBA DE AGUA CON ALOJAMIENTO	278
18-3412	KIT BOMBA DE AGUA CON ALOJAMIENTO	278
18-3413	KIT BOMBA AGUA	281

Referencia	Descripción	Página
18-3414	BASE BOMBA	61
18-3415	KIT BOMBA AGUA	280
18-3416	BASE BOMBA	61
18-3416	KIT BOMBA DE AGUA CON ALOJAMIENTO	278
18-3419	BASE BOMBA	61
18-3422	BASE BOMBA	61
18-3423	BASE BOMBA	61
18-3424	BASE BOMBA	61
18-3425	KIT BOMBA DE AGUA	65
18-3425	KIT BOMBA AGUA	280
18-3426	KIT BOMBA DE AGUA	65, 280
18-3427	KIT BOMBA DE AGUA	65, 281
18-3428-1	KIT BOMBA AGUA	281
18-3429	KIT BOMBA AGUA	281
18-3430	KIT REPARACIÓN BOMBA AGUA	281
18-3431	KIT BOMBA AGUA	281
18-3432	KIT BOMBA AGUA	278
18-3433	KIT BOMBA AGUA	281
18-3434	KIT BOMBA AGUA	280
18-3435	ALOJAMIENTO TURBINA	60, 273
18-3436	PLATINA IMPULSOR	60, 275
18-3440	KIT BOMBA AGUA	281
18-3442	KIT REPARACIÓN BOMBA DE AGUA	278
18-3443	ALOJAMIENTO IMPULSOR	273
18-3444	ALOJAMIENTO IMPULSOR	273
18-3445	BASE BOMBA	61
18-3446	KIT BOMBA DE AGUA	64
18-3448	KIT BOMBA DE AGUA	65
18-3449	ALOJAMIENTO IMPULSOR	273
18-3450	KIT BOMBA AGUA	278
18-34500	CARBURADOR	45
18-3451	KIT BOMBA AGUA	278
18-3453	KIT BOMBA AGUA	165
18-3454	KIT BOMBA AGUA	165
18-3455	CASQUILLO BOMBA DE AGUA	164
18-3456	ALOJAMIENTO IMPULSOR	273
18-3458	JUNTA BOMBA AGUA	307
18-3460	KIT BOMBA AGUA	278
18-34600	CARBURADOR	260
18-34601	CARBURADOR	260
18-34603	CARBURADOR	260
18-34604	CARBURADOR	260
18-34605	CARBURADOR	260
18-3461	KIT BOMBA DE AGUA CON ALOJAMIENTO	278
18-3462	KIT BOMBA AGUA	278
18-3463	KIT BOMBA AGUA	278
18-3464	KIT BOMBA AGUA	278
18-3465	KIT BOMBA AGUA	278
18-3466	KIT BOMBA DE AGUA CON ALOJAMIENTO	278
18-3470	KIT REPARACIÓN BOMBA AGUA	282
18-3471	KIT REPARACIÓN BOMBA AGUA	282
18-3472	KIT BOMBA AGUA	170
18-3473	KIT BOMBA AGUA	282
18-3474	KIT BOMBA AGUA	282
18-3475	KIT BOMBA AGUA	282
18-3476	KIT BOMBA AGUA	170
18-3477	KIT BOMBA AGUA	282
18-3478	KIT REPARACIÓN BOMBA AGUA	361
18-3479	KIT BOMBA AGUA	282
18-3480	BOMBA AGUA ALOJAMIENTO	341
18-3481	BOMBA AGUA ALOJAMIENTO	341
18-3482	BOMBA AGUA ALOJAMIENTO	273
18-3483	BOMBA AGUA ALOJAMIENTO	273

Referencia	Descripción	Página
18-3484	BOMBA AGUA ALOJAMIENTO	273
18-3485	BOMBA AGUA ALOJAMIENTO	273
18-3486	BOMBA AGUA ALOJAMIENTO	273
18-3489	KIT REPARACIÓN BOMBA AGUA	361
18-3490	KIT BOMBA AGUA	282
18-3491	KIT BOMBA AGUA	170
18-3492	KIT REPARACIÓN BOMBA AGUA	361
18-3493	KIT REPARACIÓN BOMBA AGUA	362
18-3494	KIT BOMBA AGUA	282
18-3495	KIT DIAFRAGMA	335
18-3496	KIT DIAFRAGMA	335
18-3497	KIT DIAFRAGMA	156
18-3497	KIT DIAFRAGMA	335
18-3498	KIT DIAFRAGMA	156
18-3498	KIT DIAFRAGMA	335
18-3499	KIT DIAFRAGMA	156
18-3499	KIT DIAFRAGMA	335
18-3500	TERMOSTATO	175
18-3501	DIAFRAGMA Y EMBALAJE	164
18-3505	DAMPER RETÉN AGUA	277
18-3507	KIT BOMBA DE AGUA	63
18-3515	KIT BOMBA REPARACIÓN	278
18-3517	KIT BOMBA DE AGUA	63
18-3518	PLATINA	274
18-3519	ALOJAMIENTO IMPULSOR	273
18-3520	PLATINA	274
18-3521	PLATINA	274
18-3522-1	KIT BOMBA DE AGUA CON ALOJAMIENTO	278
18-3523-1	KIT BOMBA DE AGUA CON ALOJAMIENTO	278
18-3524	TERMOSTATO	289
18-3525	TERMOSTATO	289
18-35302	ENSAMBLAJE BOMBA COMBUSTIBLE	263
18-3535	TERMOSTATO	58
18-3536	TERMOSTATO	58
18-3537	TERMOSTATO	58
18-3540	TERMOSTATO	289
18-3541	TERMOSTATO	289
18-3543	TERMOSTATO	175
18-3544	TERMOSTATO	175
18-3545	TERMOSTATO	175
18-3546	TERMOSTATO	175
18-3549	TERMOSTATO	59
18-3553	TERMOSTATO	59
18-3556	TERMOSTATO	59
18-3557	TERMOSTATO	175
18-3560	TERMOSTATO	175
18-3561	TERMOSTATO	175
18-3562	TAPA VÁLVULA	174
18-3563	VÁLVULA	174
18-3564	VÁLVULA	174
18-3565	RETENEDOR	175
18-3566	CODO MANGUERA	175
18-3567	VÁLVULA GOMA	174
18-3569	KIT TERMOSTATO	58
18-3570	KIT BOMBA DE AGUA	65
18-3571	KIT ALOJAMIENTO BOMBA	64
18-3572	KIT ALOJAMIENTO BOMBA	64
18-3605	KIT TERMOSTATO	58
18-3606	KIT TERMOSTATO	58
18-3607	SOPORTE	110
18-3608	KIT TERMOSTATO	289
18-3609	KIT TERMOSTATO	289
18-3611	KIT TERMOSTATO	289
18-3622	KIT TERMOSTATO	289

Referencia	Descripción	Página
18-3623	TERMOSTATO	289
18-3624	KIT TERMOSTATO	289
18-3625	TERMOSTATO	289
18-3627	TERMOSTATO	359
18-3628	TERMOSTATO	359
18-3630	TERMOSTATO	360
18-3631	ALOJAMIENTO TERMOSTATO	59
18-3632	TERMOSTATO	289
18-3643	TERMOSTATO	175
18-3669	KIT TERMOSTATO	175
18-3672	KIT TERMOSTATO	58
18-3673	KIT TERMOSTATO	175
18-3674	KIT TERMOSTATO	175
18-3675	JUNTA TERMOSTATO	89
18-36850	AGUJA Y ASIENTO	45
18-36956	FLOTADOR	45
18-3700	TUERCA HÉLICE	109
18-3701	KIT TUERCA HÉLICE	109, 367
18-3702	KIT TUERCA HÉLICE	109
18-3703	TUERCA HÉLICE	109
18-3704	TUERCA HÉLICE	109
18-3708-1	TUERCA	213
18-3709	TUERCAS HÉLICE	311
18-3710	TUERCAS HÉLICE	344
18-3714	ARANDELA DE BRONCE	109
18-3715	KIT TUERCAS	213
18-3716	KIT TUERCAS HÉLICE	213
18-3717	KIT TUERCAS HÉLICE	213
18-3719	TUERCA PIÑÓN	106
18-3726	TUERCAS HÉLICE	311
18-3726	TUERCAS HÉLICE	344
18-3732	TUERCAS HÉLICE	311
18-3735	PASADOR	344
18-3737	PASADOR	344
18-3751	TUERCA CIERRE	108
18-3753	KIT TUERCAS HÉLICE	213
18-3765	PASADOR ALOJAMIENTO	221
18-3766	BASE CAMBIO	221
18-3768	TUERCA	213
18-3771	KIT TUERCA HÉLICE	311
18-3773	TUERCAS HÉLICE	311
18-3774	KIT TUERCA HÉLICE	344
18-3775	KIT TUERCA HÉLICE	344
18-3777	KIT TUERCA HÉLICE	344
18-3778	KIT TUERCA HÉLICE	344
18-3781	KIT TUERCA HÉLICE	311
18-3782	KIT TUERCA HÉLICE	311
18-3791	ESPACIADOR HÉLICE	311
18-3792	TUERCAS HÉLICE	311
18-3800	JUNTA CULATA	192
18-38008	CONECTOR COMBUSTIBLE	358
18-3801	JUNTA CULATA	192
18-3802	JUNTA CULATA	192
18-3803	JUNTA CULATA	192
18-3804	JUNTA CULATA	85
18-3804	JUNTA CULATA	297
18-3805	JUNTA CULATA	297
18-3806	JUNTA CULATA	342
18-3807	JUNTA CULATA	342
18-3808	JUNTA CULATA	342
18-3809	JUNTA CULATA	342
18-3810	JUNTA CULATA	342
18-3813	JUNTA CULATA	342
18-3814	JUNTA CULATA	343
18-3816	JUNTA CULATA	343

Referencia	Descripción	Página
18-3819	JUNTA CULATA	343
18-3820	JUNTA CULATA	343
18-3822	JUNTA CULATA	343
18-3823	JUNTA CULATA	343
18-3824	JUNTA CULATA	343
18-3825	JUNTA CULATA	343
18-3827	JUNTA CULATA	85, 297
18-3828	JUNTA CULATA	85, 297
18-3829	JUNTA CULATA	297
18-3830	JUNTA CULATA	297
18-3831	JUNTA CULATA	297
18-3832	JUNTA CULATA	297
18-3836	JUNTA CULATA	192
18-3837	JUNTA CULATA	192
18-3838	JUNTA CULATA	192
18-3839	JUNTA CULATA	192
18-3841-2	JUNTA CULATA	192
18-3844	JUNTA CULATA	85
18-3845	JUNTA CULATA	85
18-3847	JUNTA CULATA	297
18-3848	JUNTA CULATA	297
18-3849	JUNTA CULATA	297
18-3850	JUNTA CULATA	377
18-3861	JUNTA CULATA	85
18-3862	JUNTA CULATA	85
18-3863	JUNTA CULATA	85
18-3864	JUNTA CULATA	85
18-3866	JUNTA CULATA	192
18-3871	JUNTA CULATA	85
18-3872	JUNTA CULATA	85
18-3886	JUNTA CULATA	377
18-3891	JUNTA CULATA	297
18-3892	JUNTA CULATA	297
18-3894	JUNTA CULATA	297
18-3895	JUNTA CULATA	192
18-3896	JUNTA CULATA	192
18-3898	JUNTA CULATA	192
18-3899	JUNTA TAPA AGUA	198
18-3958	AROS Y PISTONES EN LINEA	292
18-3977	AROS Y PISTONES EN LINEA	292
18-4040	AGUJAS	182
18-4077	COJINETE	293
18-4078	COJINETE	293
18-4080	MOTORES V6	292
18-4081	MOTORES V6	292
18-4082	MOTORES V6	292
18-4083	MOTORES V6	292
18-4084	MOTORES V6	292
18-4085	MOTORES V6	292
18-4091	AROS Y PISTONES EN LINEA	292
18-4096	AROS Y PISTONES EN LINEA	292
18-4097	AROS Y PISTONES EN LINEA	292
18-4099	AROS Y PISTONES EN LINEA	292
18-4128	PISTONES Y AROS	292
18-4130	PISTONES Y AROS	292
18-4132	PISTONES Y AROS V4 & V6	292
18-4135	AROS Y PISTONES EN LINEA	292
18-4138	AROS Y PISTONES EN LINEA	292
18-4141	AROS Y PISTONES EN LINEA	292
18-4142	AROS Y PISTONES EN LINEA	292
18-4145	AROS Y PISTONES EN LINEA	292
18-4146	AROS Y PISTONES EN LINEA	292
18-4148-1	BIELA	181
18-4157	BIELA	293
18-4197	ARBOL DE LEVAS	181

Referencia	Descripción	Página
18-4220D	ARANDELA	110
18-4222	ARANDELA EMPUJE	213
18-4223	ARANDELA EMPUJE	213
18-4228	ESPACIADOR	213
18-4229	ARANDELA EMPUJE	213
18-4230	ARANDELA EMPUJE	213
18-4231	ESPACIADOR	213
18-4232	ESPACIADOR	213
18-4233	ARANDELA	110
18-4248	ARANDELA	212
18-4249	TORNILLO DRENAJE MAGNÉTICO T-TEC	213
18-4253-9	TORNILLO DRENAJE ARO TÓRICO	212
18-4255	E-TEC TORNILLO DRENAJE	212
18-4261	ARANDELA	94
18-4274	ESPACIADOR HÉLICE	308
18-4275	ARANDELA	94
18-4276	TORNILLO ACERO INOXIDABLE	194
18-4299	JUNTA CULATA	378
18-4300	KIT JUNTAS MOTOR	186
18-4301	KIT JUNTAS MOTOR	186
18-4302	KIT JUNTAS MOTOR	187
18-4303-1	KIT JUNTAS MOTOR	187
18-4304-1	KIT JUNTAS MOTOR	187
18-4305	KIT JUNTAS MOTOR	187
18-43051	KIT TAPA TERMOSTATO	59
18-43052	KIT TERMOSTATO	58
18-4306	KIT JUNTAS MOTOR	188
18-4307	KIT JUNTAS MOTOR	188
18-4309	KIT JUNTAS MOTOR	188
18-4310	KIT JUNTAS MOTOR	188
18-4317	JUEGO JUNTAS BLOQUE	82
18-43175	KIT TERMOSTATO	58
18-43175	KIT TERMOSTATO	376
18-4318	KIT JUNTAS MOTOR	189
18-4319	JUEGO JUNTAS BLOQUE	82
18-4321	KIT JUNTAS MOTOR	189
18-43212	ALOJAMIENTO BOMBA	61
18-43212	BOMBA AGUA ALOJAMIENTO	377
18-4322	KIT JUNTAS MOTOR	189
18-4323	KIT JUNTAS MOTOR	190
18-4325	JUEGO JUNTAS BLOQUE	82
18-4326	JUEGO JUNTAS BLOQUE	79
18-43263	BOMBA AGUA ALOJAMIENTO	273
18-4329	KIT RETENES CIGÜÑAL	185
18-4330	KIT RETENES CIGÜÑAL	185
18-4331	KIT RETENES CIGÜÑAL	185
18-4332	KIT RETENES CIGÜÑAL	185
18-4334	JUEGO JUNTAS BLOQUE	79
18-4336	JUEGO JUNTAS BLOQUE	79
18-4337	JUEGO JUNTAS BLOQUE	81
18-4338	JUEGO JUNTAS BLOQUE	79
18-4339	JUEGO JUNTAS BLOQUE	81
18-4340	JUEGO JUNTAS BLOQUE	81
18-4351	JUEGO JUNTAS BLOQUE	83
18-4353	JUEGO JUNTAS BLOQUE	83
18-4354	JUEGO JUNTAS BLOQUE	83
18-4355	JUEGO JUNTAS BLOQUE	84
18-4356	JUEGO JUNTAS BLOQUE	84
18-4357	JUEGO JUNTAS BLOQUE	84
18-4359	JUEGO JUNTAS BLOQUE	85
18-43716	PASADOR IMPULSOR	272
18-4400	JUEGO DE JUNTAS BLOQUE MOTOR	295
18-4402	KIT JUNTAS MOTOR	190
18-4403	JUEGO DE JUNTAS BLOQUE MOTOR	295
18-4404	JUEGO DE JUNTAS BLOQUE MOTOR	295

Referencia	Descripción	Página
18-4405	JUEGO DE JUNTAS BLOQUE MOTOR	295
18-4406	KIT JUNTAS MOTOR	190
18-4407	JUEGO DE JUNTAS BLOQUE MOTOR	295
18-4409	JUEGO DE JUNTAS BLOQUE MOTOR	295
18-4411	JUEGO DE JUNTAS BLOQUE MOTOR	295
18-4412	JUEGO DE JUNTAS BLOQUE MOTOR	295
18-4413	JUEGO DE JUNTAS BLOQUE MOTOR	296
18-4415	JUEGO DE JUNTAS BLOQUE MOTOR	296
18-4417	JUEGO DE JUNTAS BLOQUE MOTOR	296
18-4419	JUEGO DE JUNTAS BLOQUE MOTOR	296
18-4420	KIT JUNTAS MOTOR	190
18-4421	KIT JUNTAS MOTOR	190
18-4427	JUEGO DE JUNTAS BLOQUE MOTOR	296
18-4428	KIT JUNTAS MOTOR	190
18-4429	JUEGO JUNTAS	190
18-4434	JUEGO JUNTAS CULATA	377
18-4435	JUEGO JUNTAS CULATA	377
18-4436	JUEGO JUNTAS CULATA	377
18-4444	LLAVE HÉLICE	109
18-4446	LLAVE HÉLICE Y KIT TUERCAS	109
18-4459	LLAVE HÉLICE	109
18-45221	IMPULSOR	163
18-4529	KIT BOMBA AGUA	170
18-4531	KIT REPARACIÓN BOMBA DE AGUA	65
18-45312	IMPULSOR	60, 163
18-4536	KIT REPARACIÓN BOMBA AGUA	362
18-4537	KIT BOMBA AGUA	170
18-4539	IMPULSOR	163
18-45404	IMPULSOR	376
18-4567	BOMBA AGUA ALOJAMIENTO	273
18-4568	ALOJAMIENTO IMPULSOR	164
18-4569	ALOJAMIENTO IMPULSOR	164
18-4571	ALOJAMIENTO IMPULSOR	164
18-4577	PLATINA	60
18-4698	ARANDELA LLENADO/VACIADO	94
18-4698	ARANDELA DRENAJE / LLENADO	308
18-4712	CAMISA PISTÓN	181
18-4807	TAPA COJINETE EJE	221
18-4826	TORNILLO	212
18-4830	CARCASA COLA	107
18-48317	KIT COMPLETO BOMBA DE AGUA	65, 377
18-4832	CARCASA COLA	107
18-4840	TRANSMISIÓN COMPLETA PARTE INFERIOR	212
18-4841	TRANSMISIÓN COMPLETA PARTE INFERIOR	212
18-4843	TRANSMISIÓN COMPLETA PARTE INFERIOR	212
18-4850	COLA COMPLETA	107
18-4851	COLA COMPLETA	107
18-4858	ARANDELA	93
18-48619	KIT COMPLETO BOMBA DE AGUA	278
18-4904	ARRANQUE UNIVERSAL, CUERDA Y MANETA	201
18-4911	CUERDA STARTER	201
18-4913	CUERDA STARTER	201
18-4914	CUERDA STARTER	201
18-4915	CUERDA DE ARRANQUE	94
18-50000	MANETA	255
18-50001	MANETA	255
18-5001	KIT ENCENDIDO	137
18-5002	KIT ENCENDIDO	137
18-5003	KIT ENCENDIDO	137
18-5006	KIT ENCENDIDO	137
18-5007	KIT ENCENDIDO	24
18-5011	KIT ENCENDIDO	137

Referencia	Descripción	Página
18-5012	KIT ENCENDIDO	24
18-51000	MUELLE ARRANQUE DE RETR.	378
18-51001	MUELLE	308
18-51002	MUELLE	308
18-51003	MUELLE	308
18-5110	BOBINA ENCENDIDO	249
18-5111	BOBINA ENCENDIDO	249
18-5112	BOBINA ENCENDIDO	250
18-5113	BOBINA ENCENDIDO	250
18-5128	BOBINA ENCENDIDO	250
18-5130	CDI	249
18-5131	CDI	249
18-5132	CDI	249
18-5133	BOBINA ENCENDIDO	373
18-5134	CDI	373
18-5135	CDI	250
18-5136	CDI	250
18-5138	BOBINA ENCENDIDO	250
18-5139	KIT ENCENDIDO	24
18-5140	JUEGO CONTACTOS	25
18-5141	CONJUNTO CONTACTO	137
18-5143	BOBINA	373
18-5144	CDI	333
18-5148	JUEGO CONTACTOS	25
18-5151	BOBINA ENCENDIDO	333
18-5152	BOBINA ENCENDIDO	333
18-5153	JUEGO CONTACTOS	25
18-5156	CONJUNTO CONTACTO	137
18-5157	CONJUNTO CONTACTO	137
18-5163	BOBINA ENCENDIDO	138
18-5165	BOBINA	373
18-5166	BOBINA ENCENDIDO	373
18-5169	CONDENSADOR	25
18-5170	BOBINA ENCENDIDO	138
18-5172	BOBINA ENCENDIDO	138
18-5176	KIT BOBINA ENCENDIDO	138
18-5178	BOBINA ENCENDIDO	25
18-5179	BOBINA ENCENDIDO	138
18-5180	BOBINA ENCENDIDO	25
18-5181	BOBINA ENCENDIDO	25
18-5181	BOBINA ENCENDIDO	138
18-5182	BOBINA ENCENDIDO	25
18-5183	BOBINA CARGA	250
18-5185	BOBINA ENCENDIDO	25
18-5185	BOBINA ENCENDIDO	373
18-5186	BOBINA ENCENDIDO	25
18-5187	BOBINA ENCENDIDO	25
18-5192	BOBINA ENCENDIDO	138
18-5194	BOBINA ENCENDIDO	138
18-5195	BOBINA ENCENDIDO	250
18-5196	BOBINA ENCENDIDO	138
18-5199	CONDENSADOR	137
18-5200	CONDENSADOR	137
18-5205	CONDENSADOR	137
18-5206	CONDENSADOR	25
18-5207	CONDENSADOR	25
18-5224	TERMINAL CABLE BUJÍAS	30, 144, 251, 333, 355, 373
18-5225	KIT CABLE BUJÍAS	30, 144, 251, 333, 355, 373
18-5226	CABLE ENCENDIDO	30, 144, 251, 333, 355, 373
18-5433	BOBINA ENCENDIDO	25
18-55505	MOTOR DE ARRANQUE FUERABORDA	42
18-55506	MOTOR DE ARRANQUE FUERABORDA	42
18-56001	ACOPLAMIENTO ESCOBILLA	375

Referencia	Descripción	Página
18-56005	ALOJAMIENTO ESCOBILLAS	255
18-56007	ALOJAMIENTO ESCOBILLAS	255
18-56009	ESCOBILLA	334
18-5601	MOTOR DE ARRANQUE	40
18-5602	MOTOR DE ARRANQUE	40
18-5605	MOTOR DE ARRANQUE	40
18-5606	MOTOR DE ARRANQUE	40
18-5608	MOTOR DE ARRANQUE	41
18-5610	MOTOR DE ARRANQUE	41
18-5611	MOTOR DE ARRANQUE	41
18-5612	ARRANQUE FUERABORDA	150
18-5617	ARRANQUE FUERABORDA	150
18-5619	ARRANQUE FUERABORDA	150
18-5620	MOTOR DE ARRANQUE	41
18-5621	MOTOR DE ARRANQUE	41
18-5624	ARRANQUE FUERABORDA	150
18-5627	ARRANQUE FUERABORDA	150
18-5628	ARRANQUE FUERABORDA	150
18-5629	ARRANQUE FUERABORDA	150
18-5630	ARRANQUE FUERABORDA	150
18-5631	ARRANQUE FUERABORDA	150
18-5632	ARRANQUE FUERABORDA	150
18-5634	ARRANQUE FUERABORDA	150
18-5636	MOTOR DE ARRANQUE	41
18-5640	ARRANQUE FUERABORDA	149
18-5642	MOTOR DE ARRANQUE	40
18-5648	ARRANQUE FUERABORDA	150
18-5650	PIÑÓN	42
18-5655	CONJUNTO PIÑONES	151
18-5656	PIÑÓN	42
18-5658	PIÑÓN	42
18-5671	CONJUNTO PIÑONES	151
18-5674	CONJUNTO PIÑONES	42, 151
18-5678	CONJUNTO PIÑONES	151
18-5679	CONJUNTO PIÑONES	151
18-5697	KIT ESCOBILLAS Y MUELLES	42, 151
18-5705	POWER TRIM RELÉ	146
18-5707	RECTIFICADOR	35
18-5708	RECTIFICADOR	148
18-5709	RECTIFICADOR	148
18-5729	RELE POWER TRIM	36
18-5731	RELÉ, MOTOR ARRANQUE	335
18-5732	REGULADOR DE VOLTAJE	35
18-5737	RELE POWER TRIM	36
18-5741	REGULADOR DE VOLTAJE	35
18-5743	REGULADOR DE VOLTAJE	35
18-5746	ENSAMBLAJE STATOR	253
18-5750	TAPA BUJÍAS UNIVERSAL	30, 144, 251, 333, 355, 373
18-5752	BUJÍA UNIVERSAL	30, 144, 251, 333, 355, 373
18-5755	CAJA ENCENDIDO	140
18-5758	CAJA ENCENDIDO	140
18-5759	CAJA ENCENDIDO	140
18-5760	CAJA ENCENDIDO	140
18-5761	CAJA ENCENDIDO	140
18-5762	CAJA ENCENDIDO	140
18-5763	CAJA ENCENDIDO	140
18-5764	CAJA ENCENDIDO	140
18-5766	CAJA ENCENDIDO	140
18-5767	CAJA ENCENDIDO	140
18-5768	CAJA ENCENDIDO	140
18-5770	CAJA ENCENDIDO	140
18-5771	CAJA ENCENDIDO	141
18-5772	CAJA ENCENDIDO	141
18-5773	CAJA ENCENDIDO	141

Referencia	Descripción	Página
18-5774	CAJA ENCENDIDO	141
18-5775	CAJA INTERRUPTOR	26
18-5776	CAJA INTERRUPTOR	26
18-5777	CAJA INTERRUPTOR	26
18-5778	CAJA INTERRUPTOR	26
18-5781	CAJA ENCENDIDO	141
18-5782	CAJA ENCENDIDO	141
18-5783	CAJA ENCENDIDO	141
18-5784	CAJA ENCENDIDO	141
18-5785	CAJA ENCENDIDO	141
18-5786	CONEXIÓN CAJA INTERRUPTOR	26
18-5788	CONEXIÓN CAJA INTERRUPTOR	26
18-5790	CONEXIÓN CAJA INTERRUPTOR	26
18-5791	CONEXIÓN CAJA INTERRUPTOR	26
18-5792	CONEXIÓN CAJA INTERRUPTOR	26
18-5793	CONEXIÓN CAJA INTERRUPTOR	26
18-5794	CAJA ENCENDIDO	141
18-5794-1	CAJA ENCENDIDO	141
18-5797	TRIGGER	33
18-5798	TRIGGER	33
18-5801	SOLENOIDE	146
18-5802	SOLENOIDE	35
18-5807	SOLENOIDE	146
18-5808	SOLENOIDE	35
18-5808	SOLENOIDE	146
18-5810	SOLENOIDE	35
18-5811	SOLENOIDE	35
18-5813	SOLENOIDE	146
18-5814	SOLENOIDE	146
18-5815	SOLENOIDE	35
18-5816	SOLENOIDE	35
18-5817	SOLENOIDE	35
18-5818	SOLENOIDE	35
18-5819	SOLENOIDE	35
18-5819	SOLENOIDE	253
18-5820	SOLENOIDE	35
18-5821	MOTOR ARRANQUE SOLENOIDE	35, 253
18-5822	SOLENOIDE ARRANQUE	35
18-5823	SOLENOIDE	146
18-5825	REGULADOR / RECTIFICADOR	148
18-5826	REGULADOR / RECTIFICADOR	148
18-5827	REGULADOR / RECTIFICADOR	148
18-5828	REGULADOR / RECTIFICADOR	148
18-5829	REGULADOR / RECTIFICADOR	148
18-5830	REGULADOR / RECTIFICADOR	148
18-5831	REGULADOR / RECTIFICADOR	148
18-5832	REGULADOR / RECTIFICADOR	148
18-5833	SOLENOIDE	146
18-5834	SOLENOIDE	36
18-5836	SOLENOIDE	36
18-5849	RELE, TAPA, TRIM	36
18-5850	RELE, TAPA	36
18-5851	RELE, TAPA	36
18-5852	RELE, TAPA	36
18-5853	SOLENOIDE	253
18-5854	STATOR	33
18-5855	STATOR	33
18-5856	STATOR	33
18-5857	STATOR	33
18-5859	STATOR	33
18-5860	STATOR	33
18-5863	STATOR	32
18-5864	STATOR	32
18-5865	STATOR	32
18-5867	STATOR	32

Referencia	Descripción	Página
18-5870	STATOR	32
18-5871	STATOR	32
18-5873	KIT STATOR	32
18-5874	KIT STATOR	33
18-5876	STATOR	33
18-5877	STATOR	145
18-5878	STATOR	145
18-5879	SOLENOIDE	253
18-5881	CAJA INTERRUPTOR	26
18-5883	CAJA ENCENDIDO	141
18-5884	SENSOR ÓPTICO	142
18-5885	CAJA ENCENDIDO	142
18-5886	CAJA ENCENDIDO	142
18-5887	CAJA ENCENDIDO	142
18-5891	CAJA ENCENDIDO	142
18-5893	CAJA ENCENDIDO	142
18-5896	SENSOR DE TEMPERATURA	59
18-5909	ARRANQUE FUERABORDA	149
18-5929	ALTERNADOR	39
18-60103	TAPÓN DE VACIADO JUNTAS	378
18-60103-50	TAPÓN DE VACIADO JUNTAS	378
18-60508	JUNTA TERMOSTATO	303
18-60512	JUNTA	307
18-60513	JUNTA	307
18-60518	JUNTA TAPA CILINDRO	307
18-60519	JUNTA TAPA CILINDRO	307
18-60520	JUNTA TAPA CILINDRO	307
18-60521	JUNTA TAPA CILINDRO	307
18-60522	JUNTA TAPA CILINDRO	307
18-60523	JUNTA TAPA CILINDRO	307
18-60527	JUNTA MOTOR	307
18-60528	JUNTA MOTOR	307
18-60529	JUNTA COLECTOR ESCAPE	307
18-60530	JUNTA TAPA ESCAPE	307
18-60532	JUNTA TAPA ESCAPE	307
18-60534	JUNTA COLECTOR	307
18-60535	JUNTA COLECTOR	307
18-60540	JUNTA TERMOSTATO	307
18-60541	JUNTA TAPA BOMBA AGUA	307
18-60916	JUNTA CULATA	85
18-60916	CILINDRO JUNTA CULATA	378
18-60917	JUNTA TAPA CILINDRO	89
18-60917	JUNTA TAPA CILINDRO	378
18-60918	JUNTA BASE MOTOR	91, 378
18-60919	JUNTA TAPA ESCAPE	91, 378
18-60920	JUNTA TERMOSTATO	91, 378
18-6111 AL 009355 Zinc	ÁNODO	309
18-6112 Mag 025962 Zinc	ÁNODO	309
18-6118 AL	ÁNODO CILINDRO	309
18-6119 AL 18-6119 Zinc	ÁNODO	309
18-6120 AL 025961 Zinc	ÁNODO	309
18-6121 AL 18-6121 Zinc	ÁNODO	309
18-6122 AL 18-6122 Zinc	ÁNODO	309
18-6241M 009354Zinc 18-6011 AL	ANODOS	110
18-6245	TORNILLO MONTAJE ANODO	111
18-6246	TORNILLO TRIM	309
18-6250	KIT REPARACIÓN MOTOR DE ARRANQUE	42
18-6250	ARRANQUE FUERABORDA KIT REPARACIÓN	151

Referencia	Descripción	Página
18-6251	KIT REPARACIÓN MOTOR DE ARRANQUE	42
18-6251	ARRANQUE FUERABORDA KIT REPARACIÓN	151
18-6252	KIT REPARACIÓN MOTOR TILT/TRIM	145
18-6258	MOTOR TILT/TRIM	356
18-6259	MOTOR TILT/TRIM	258
18-6273-1	MOTOR TILT/TRIM	31
18-6274	MOTOR TILT/TRIM	32
18-6277	ALOJAMIENTO TILT/TRIM	145
18-6280	ALOJAMIENTO TILT/TRIM	145
18-6281	MOTOR TILT/TRIM	145
18-6282	MOTOR DE ARRANQUE	40
18-6283	MOTOR DE ARRANQUE	40
18-6285	ALOJAMIENTO TILT/TRIM	145
18-63966	JUUNTA CULATA CILINDRO	307
18-6409	ALTERNADOR	356
18-6410	MOTOR ARRANQUE FUERABORDA	253
18-6411	MOTOR ARRANQUE FUERABORDA	253
18-6412	MOTOR ARRANQUE FUERABORDA	254
18-6413	MOTOR ARRANQUE FUERABORDA	254
18-6414	ARRANQUE FUERABORDA	334
18-6415	MOTOR ARRANQUE FUERABORDA	254
18-6416	ARRANQUE FUERABORDA	334
18-6417	ARRANQUE FUERABORDA	334
18-6418	MOTOR ARRANQUE	374
18-6419	ARRANQUE FUERABORDA	334
18-6420	MOTOR ARRANQUE FUERABORDA	254
18-6421	MOTOR ARRANQUE FUERABORDA	254
18-64217	JUEGO JUNTAS BLOQUE	85
18-6422	MOTOR ARRANQUE FUERABORDA	254
18-64221	JUEGO JUNTAS CULATA	377
18-6423	MOTOR ARRANQUE FUERABORDA	254
18-6425	MOTOR DE ARRANQUE	40, 254
18-6426	MOTOR ARRANQUE FUERABORDA	254
18-6427	MOTOR ARRANQUE FUERABORDA	254
18-6428	MOTOR ARRANQUE	334
18-6429	ARRANQUE FUERABORDA	334
18-6430	MOTOR ARRANQUE	374
18-6431	MOTOR ARRANQUE	374
18-6432	MOTOR ARRANQUE	374
18-6433	ARRANQUE FUERABORDA	356
18-6434	ARRANQUE FUERABORDA	149
18-6435	MOTOR DE ARRANQUE	39
18-6436	MOTOR DE ARRANQUE	40
18-6437	MOTOR DE ARRANQUE	40
18-6438	MOTOR DE ARRANQUE	40
18-6440	MOTOR DE ARRANQUE	40
18-64415	KIT SENSOR	305
18-6445	MOTOR ARRANQUE	356
18-6448	KIT CONVERSIÓN ARRANQUE ELÉCTRICO	32, 375
18-6454	ALTERNADOR	39
18-6455	ALTERNADOR	39
18-6475	ALTERNADOR	356
18-6476	ALTERNADOR	356
18-6500	CABLEADO ALTERNADOR	39
18-6501	MUELLA DE ARRANQUE	201
18-6503	MUELLA DE ARRANQUE	201
18-6506	MUELLE DE ARRANQUE	94
18-6509	MUELLA DE ARRANQUE	201
18-6511	MUELLA DE ARRANQUE	201
18-6512	UÑA ARRANQUE	201
18-6513	UÑA ARRANQUE	201
18-6522	MUELLA DE ARRANQUE	201
18-6526	CABLE ACELERADOR	224
18-65450	INTERRUPTOR PARADA MOTOR	251

Referencia	Descripción	Página
18-6742	MOTOR TRIM	356
18-6743	MOTOR TRIM	356
18-6744	MOTOR TRIM	145
18-6745	MOTOR TRIM	356
18-6748	MOTOR TRIM	255
18-6751	VÁLVULA	30
18-6756	MOTOR TILT/TRIM	145
18-6757	MOTOR TILT/TRIM	31
18-6759	MOTOR TILT/TRIM	145
18-6760	MOTOR TRIM	258
18-6761	MOTOR TILT/TRIM	145
18-6762	MOTOR TILT/TRIM	145
18-6763	MOTOR TRIM	31
18-6765	MOTOR TRIM	31
18-6767-1	MOTOR TILT/TRIM	145
18-6771	DEPÓSITO TILT/TRIM	30
18-6773	MOTOR TILT/TRIM	31
18-6774	MOTOR TILT/TRIM	31
18-6775	MOTOR TILT/TRIM	31
18-6777	MOTOR TILT/TRIM	31
18-6778	DEPÓSITO TILT/TRIM	31
18-6780	MOTOR TILT/TRIM	145
18-6781	MOTOR TILT/TRIM	258
18-6782	MOTOR TILT/TRIM	258
18-6783	MOTOR TILT/TRIM	258
18-6785	MOTOR TILT/TRIM	335
18-6786-1	MOTOR TILT/TRIM	335
18-6787	MOTOR TILT/TRIM	258
18-6788	MOTOR TILT/TRIM	258
18-6789	MOTOR TILT/TRIM	258
18-6793	MOTOR TRIM	335
18-6793	MOTOR TRIM	356
18-6798	MOTOR TRIM	255
18-6811	MOTOR POWER TRIM	258
18-6812	MOTOR TRIM	258
18-6815	MOTOR TRIM	145
18-6816	MOTOR TRIM	39
18-6816	MOTOR TRIM	145
18-6821	MOTOR TRIM	258
18-6823	CABLEADO	145, 258, 335, 356, 374
18-6824	MOTOR DE ARRANQUE FUERABORDA	41
18-6825	MOTOR DE ARRANQUE	41
18-6826	ARRANQUE	151
18-6827	MOTOR ARRANQUE	334
18-6828	MOTOR DE ARRANQUE	41
18-6829	MOTOR DE ARRANQUE	41
18-6831	MOTOR ARRANQUE	334
18-6832	MOTOR ARRANQUE	254
18-6833	MOTOR ARRANQUE	254
18-6836	MOTOR TRIM	258
18-6837	MOTOR TRIM	335
18-6840	ALTERNADOR	39
18-6861	MOTOR ARRANQUE	254
18-6863	ARRANQUE	151
18-6864	MOTOR DE ARRANQUE	41
18-6940	MOTOR DE ARRANQUE	42
18-6941	MOTOR ARRANQUE	334
18-6942	MOTOR ARRANQUE	254
18-6943	MOTOR DE ARRANQUE	42, 254
18-6945	MOTOR ARRANQUE	151, 334
18-6959	MOTOR ARRANQUE	356
18-6961	MOTOR ARRANQUE	255
18-7002	KIT CARBURADOR	259
18-7004	KIT CARBURADOR	43

Referencia	Descripción	Página
18-7005	KIT CARBURADOR	43
18-7006-1	KIT CARBURADOR	43
18-7007	KIT CARBURADOR	44
18-7010	KIT CARBURADOR	152
18-7013	KIT CARBURADOR	44
18-7021	KIT CARBURADOR	44
18-7024	KIT CARBURADOR	152
18-7026	KIT CARBURADOR	152
18-7042	KIT CARBURADOR	152
18-7043	KIT CARBURADOR	152
18-7044	KIT SERVICIO DE VÁLVULA	153
18-7046	KIT CARBURADOR	152
18-7047	VÁLVULA AGUJA	359
18-7048	VÁLVULA AGUJA	359
18-7049	VÁLVULA DE AGUJA	260
18-7050	KIT CARBURADOR	359
18-7051	KIT CARBURADOR	359
18-7052	KIT CARBURADOR	359
18-7053	KIT CARBURADOR	359
18-7054	VÁLVULA DE AGUJA	260
18-7055	VÁLVULA DE AGUJA	260
18-7056	VÁLVULA DE AGUJA	261
18-7057	AGUJA Y ASIENTO	45
18-7058	KIT CARBURADOR	259
18-7059	KIT CARBURADOR	259
18-7060	VÁLVULA DE AGUJA	261
18-7061	AGUJA Y ASIENTO	45
18-7062	AGUJA	45
18-7063	FLOTADOR	261
18-7064	FLOTADOR	261
18-7065	FLOTADOR	261
18-7066	FLOTADOR	261
18-7067	FLOTADOR	261
18-7068	FLOTADOR	261
18-7069	FLOTADOR	261
18-7073	VÁLVULA DE AGUJA	261
18-7079	VÁLVULA DE AGUJA	261
18-7083	BOMBA COMBUSTIBLE	53
18-70936	MANGUITO (CABEZA DE CILINDRO ESTRIBOR)	186
18-70937	MANGUITO (CABEZA DE CILINDRO ESTRIBOR)	186
18-7106	EMBALAJE DE AGUA	153
18-7110	ARO TÓRICO	192
18-71102	KIT REP. CAVA CONTROL	221
18-7113-9	ARO TÓRICO	58
18-7118	ARO	347
18-7140	ARO	347
18-7198	ARO	367
18-72000	FLOTADOR	45
18-7208	FLOTADOR	45
18-7209	FLOTADOR	45
18-7210	FLOTADOR	153
18-7211-1	KIT CARBURADOR	44
18-7212	KIT CARBURADOR	44
18-7213	KIT CARBURADOR	44
18-7214	KIT CARBURADOR	44
18-7215	KIT CARBURADOR	44
18-7219	KIT CARBURADOR	152
18-7221	KIT CARBURADOR	152
18-7222	KIT CARBURADOR	152
18-7223	KIT CARBURADOR	153
18-7226	KIT CARBURADOR	44
18-7233	AGUJA Y ASIENTO	45
18-7248	KIT CARBURADOR	153
18-7249	FLOTADOR	45

Referencia	Descripción	Página
18-72656	TAPÓN DRENAJE Y JUNTA	378
18-7290	KIT CARBURADOR	44, 259, 376
18-7291	KIT CARBURADOR	44, 259, 376
18-7293	KIT CARBURADOR	44, 259
18-7295	VÁLVULA DE AGUJA	45
18-7296	RETENEDOR AJUSTE AGUA	153
18-7334	BOMBA COMBUSTIBLE	263
18-7340	BOMBA COMBUSTIBLE	263
18-7341	BOMBA COMBUSTIBLE	263
18-7342	BOMBA COMBUSTIBLE	263
18-7343	BOMBA COMBUSTIBLE	263
18-7349	BOMBA COMBUSTIBLE	263
18-7350	BOMBA COMBUSTIBLE	155
18-7351	BOMBA COMBUSTIBLE	155
18-7352	BOMBA COMBUSTIBLE	155
18-7353	BOMBA COMBUSTIBLE	155
18-7354	KIT CARBURADOR	43
18-7355	KIT CARBURADOR	43
18-7356	KIT CARBURADOR	43
18-7367	KIT BOMBA COMBUSTIBLE	264
18-7368	KIT BOMBA COMBUSTIBLE	264
18-7369	KIT BOMBA COMBUSTIBLE	264
18-7380	FLOTADOR	45
18-7381	FLOTADOR	45
18-7382	FLOTADOR	45
18-7388	DIAFRAGMA	263
18-7389	DIAFRAGMA	263
18-73891	ESPACIADOR HÉLICE	310
18-73892	TUERCA HÉLICE	311
18-7390	DIAFRAGMA	263
18-7391	DIAFRAGMA	263
18-73914	ESPACIADOR HÉLICE	310
18-73918	ARANDELA HÉLICE	310
18-7392	FLOTADOR	261
18-7393	FLOTADOR	261
18-73964	KIT DE TUERCAS	378
18-73978	ARANDELA TUERCA HÉLICE	310
18-73979	ARANDELA HÉLICE	310
18-73990	KIT TUERCA HÉLICE	310
18-73994	KIT TUERCA HÉLICE	311
18-73995	KIT TUERCA HÉLICE	310
18-73996	KIT TUERCA HÉLICE	310
18-7400	ARO TÓRICO JUNTA CULATA	85
18-74108	KIT RETÉN ALOJAMIENTO ENGRANAJE	229
18-7428	ARO TÓRICO	199
18-74501	KIT RETÉN ALOJAMIENTO ENGRANAJE	116, 325
18-74504	KIT RETÉN ALOJAMIENTO ENGRANAJE	325
18-74507	KIT RETÉN ALOJAMIENTO ENGRANAJE	325
18-74510	KIT RETÉN ALOJAMIENTO ENGRANAJE	325
18-74512	KIT RETÉN ALOJAMIENTO ENGRANAJE	325
18-74515	KIT RETÉN ALOJAMIENTO ENGRANAJE	325
18-74527	KIT RETÉN ALOJAMIENTO ENGRANAJE	325
18-74535	KIT RETÉN ALOJAMIENTO ENGRANAJE	325
18-74540	KIT RETÉN	325
18-74544	KIT RETÉN ALOJAMIENTO ENGRANAJE	325
18-74546	KIT RETÉN ALOJAMIENTO ENGRANAJE	325
18-74610	KIT SELLADO UNIDAD INFERIOR	377
18-74611	KIT SELLADO UNIDAD INFERIOR	377
18-74805	KIT SELLADO UNIDAD INFERIOR	377
18-7481	ARO TÓRICO	199
18-7484	ARO	258
18-7486	ARO, CAZOLETA FILTRO COMBUSTIBLE	267
18-7487	ARO, ELEMENTO FILTRO COMBUSTIBLE	267
18-7488	JUNTA, CAZOLETA FILTRO COMBUSTIBLE	267

Referencia	Descripción	Página
18-7494	BOBINA	355
18-7516	FILTRO COMBUSTIBLE	267
18-7517	FILTRO COMBUSTIBLE	267
18-7552	SENSOR, MAP	359
18-7558	SENSOR	359
18-7559	SENSOR	359
18-7606	SENSOR DE AGUA	270
18-7655	SENSOR OXÍGENO	270
18-7656	SENSOR OXÍGENO	270
18-7658	SENSOR OXÍGENO	359
18-7659	SENSOR OXÍGENO	359
18-76695	ARO TÓRICO	378
18-7710	FILTRO COMBUSTIBLE	267
18-7711	SEPARADORES COMBUSTIBLE/ AGUA	336
18-7712	FILTRO COMBUSTIBLE (EN LINEA)	57, 358, 375
18-7713	FILTRO COMBUSTIBLE (EN LINEA)	57, 267
18-7714	FILTRO COMBUSTIBLE (EN LINEA)	57
18-7716	FILTRO COMBUSTIBLE	159, 336
18-7718	FILTRO COMBUSTIBLE (EN LINEA)	57
18-7719	FILTRO COMBUSTIBLE	159, 336
18-7720	SEPARADORES COMBUSTIBLE/ AGUA	357
18-7722	FILTRO COMBUSTIBLE	159
18-7735	SEPARADORES COMBUSTIBLE/ AGUA	336
18-7736	KIT CARBURADOR	259
18-7737	KIT CARBURADOR	259
18-7738	KIT CARBURADOR	44, 259
18-7739	KIT CARBURADOR	259
18-7740	KIT CARBURADOR	259
18-7741	KIT CARBURADOR	259
18-7742	KIT CARBURADOR	259
18-7743	KIT CARBURADOR	44, 259
18-7744	KIT CARBURADOR	259
18-7747	KIT CARBURADOR	259
18-7750-1	KIT CARBURADOR	45
18-7752	KIT CARBURADOR	336
18-7753	KIT CARBURADOR	336
18-7754	KIT CARBURADOR	336
18-7755	KIT CARBURADOR	336
18-7756	KIT CARBURADOR	259
18-7758	FILTRO ACEITE	78
18-7759	KIT CARBURADOR	259
18-7761	KIT RECUPERACIÓN CARBURADOR	152, 335
18-7765	KIT CARBURADOR	45, 259, 376
18-7766	KIT CARBURADOR	260
18-7767	KIT CARBURADOR	260
18-7768	KIT CARBURADOR	260
18-7769	KIT CARBURADOR	45, 260
18-7770	KIT CARBURADOR	45, 260
18-7772	KIT CARBURADOR	260
18-7773	KIT RECUPERACIÓN CARBURADOR	152, 335
18-7774	SOPORTE DE ALUMINIO COMPACTO	56, 158, 266
18-7775	SOPORTE FILTRO GASOLINA	55, 265
18-7775-1	KIT FILTROS DE 21 MICRAS PARA MOTORES CON CARBURADOR	55, 157, 265
18-7776	SOPORTE FILTRO GASOLINA	55, 265
18-7776-1	KIT FILTROS DE 21 MICRAS PARA MOTORES CON CARBURADOR	55, 157, 265
18-7777	SOPORTE FILTRO GASOLINA	55, 265
18-7777-1	KIT FILTROS DE 21 MICRAS PARA MOTORES CON CARBURADOR	55, 157, 265
18-7781	FILTRO COMBUSTIBLE	267
18-7782	FILTRO COMBUSTIBLE	267
18-7785	SEPARADORES COMBUSTIBLE/ AGUA	357
18-7786	SEPARADORES COMBUSTIBLE/ AGUA	357
18-7787	KIT BOMBA COMBUSTIBLE	263
18-7788	KIT BOMBA COMBUSTIBLE	263

Referencia	Descripción	Página
18-7796	VÁLVULA DE COMPROBACIÓN	156
18-7797	KIT BOMBA COMBUSTIBLE	264
18-7798	KIT BOMBA COMBUSTIBLE	264
18-7799	KIT BOMBA COMBUSTIBLE	264
18-7800	KIT BOMBA COMBUSTIBLE	155
18-7801	KIT BOMBA COMBUSTIBLE	155
18-7802	FILTRO COMBUSTIBLE	57
18-7804	KIT BOMBA COMBUSTIBLE	49
18-7806-1	KIT BOMBA COMBUSTIBLE	49
18-7807	KIT BOMBA COMBUSTIBLE	49
18-7808	KIT BOMBA COMBUSTIBLE	49
18-7809	KIT BOMBA COMBUSTIBLE	49
18-7810	KIT BOMBA COMBUSTIBLE	49
18-7811	KIT BOMBA COMBUSTIBLE	49
18-7812	KIT BOMBA COMBUSTIBLE	49
18-7813	KIT BOMBA COMBUSTIBLE	49
18-7814	KIT BOMBA COMBUSTIBLE	49
18-7815	KIT BOMBA COMBUSTIBLE	49
18-7817	KIT BOMBA COMBUSTIBLE	49
18-7818-1	KIT BOMBA COMBUSTIBLE	49
18-7820	KIT BOMBA COMBUSTIBLE	155
18-7821	KIT BOMBA COMBUSTIBLE	155
18-7822	KIT BOMBA COMBUSTIBLE	155
18-7823	KIT BOMBA COMBUSTIBLE	156
18-7826	FILTRO COMBUSTIBLE	159
18-7828-1	FILTRO COMBUSTIBLE	58, 267, 375
18-7829	FILTRO COMBUSTIBLE	58, 267, 375
18-7830	FILTRO COMBUSTIBLE	58, 267, 375
18-7831	FILTRO COMBUSTIBLE	58, 267, 375
18-7832	FILTRO COMBUSTIBLE	57
18-7833	MEMBRANA KIT BOMBA	49, 264
18-7834	MEMBRANA KIT BOMBA	49, 264
18-7837	MEMBRANA KIT BOMBA	49, 264
18-7838	MEMBRANA KIT BOMBA	49, 264
18-7839	MEMBRANA KIT BOMBA	49, 264
18-7840	MEMBRANA KIT BOMBA	49, 264
18-7841	DIAFRAGMA BOMBA COMBUSTIBLE	264
18-7842	DIAFRAGMA BOMBA COMBUSTIBLE	264
18-7843	DIAFRAGMA BOMBA COMBUSTIBLE	264
18-7844	FILTRO DE RECAMBIO DE 10 MICRAS	266
18-7845	FILTRO DE RECAMBIO DE 10 MICRAS	266
18-7847	MEMBRANA KIT BOMBA	49
18-7848-1	KIT FILTROS DE 21 MICRAS PARA MOTORES CON CARBURADOR	55, 157, 265
18-7848-2	KIT FILTROS DE 21 MICRAS PARA MOTORES CON CARBURADOR	55, 157, 265
18-7852-1	KIT FILTROS DE 21 MICRAS PARA MOTORES CON CARBURADOR	55, 157, 265
18-7852-2	KIT FILTROS DE 21 MICRAS PARA MOTORES CON CARBURADOR	55, 157, 265
18-7853-1	SOPORTE FILTRO GASOLINA	55, 265
18-7865	FILTRO DE RECAMBIO DE 10 MICRAS	266
18-7866	FILTRO DE RECAMBIO DE 10 MICRAS	266
18-7895	FILTRO ACEITE	186, 343
18-7896	FILTRO ACEITE	186, 343
18-7897	FILTRO ACEITE	186, 343
18-7901	FILTRO ACEITE	78
18-7901	FILTRO ACEITE 4-CICLO FUERABORDA	294
18-7902	FILTRO ACEITE 4-CICLO FUERABORDA	294
18-7903	FILTRO ACEITE	186, 343
18-7905	FILTRO ACEITE	343
18-7906-1	FILTRO ACEITE	78, 294
18-7909	FILTRO ACEITE	365
18-7911-1	FILTRO ACEITE	293, 365, 377
18-7913	FILTRO ACEITE	78, 365
18-7914	FILTRO ACEITE	78

Referencia	Descripción	Página
18-7915-1	FILTRO ACEITE	186, 343
18-7916	FILTRO ACEITE	186
18-7918	FILTRO ACEITE	78
18-7919	FILTROS DE RECAMBIO DE 10 MICRAS Y KITS CON CAZOLETA DE DRENAJE	266
18-7920	FILTROS DE RECAMBIO DE 10 MICRAS Y KITS CON CAZOLETA DE DRENAJE	266
18-7921	FILTRO ACEITE	78
18-7922-1	FILTROS DE RECAMBIO DE 10 MICRAS Y KITS CON CAZOLETA DE DRENAJE	266, 336
18-7924	FILTROS DE RECAMBIO DE 10 MICRAS Y KITS CON CAZOLETA DE DRENAJE	266
18-7928-1	FILTROS DE RECAMBIO DE 10 MICRAS Y KITS CON CAZOLETA DE DRENAJE	266
18-7929	FILTROS DE RECAMBIO DE 10 MICRAS Y KITS CON CAZOLETA DE DRENAJE	266
18-7932-1	KIT FILTROS DE 10 MICRAS CON CAZOLETA DE DRENAJE	266
18-7936	ELEMENTO FILTRO COMBUSTIBLE	57, 336
18-7937-1	KIT FILTROS DE 10 MICRAS CON CAZOLETA DE DRENAJE	266
18-7938	KIT FILTROS DE 10 MICRAS CON CAZOLETA DE DRENAJE	266
18-7944	FILTRO DE RECAMBIO DE 10 MICRAS	266
18-7945	FILTRO DE RECAMBIO DE 10 MICRAS	266
18-7947	FILTROS DE RECAMBIO DE 10 MICRAS Y KITS CON CAZOLETA DE DRENAJE	266, 336, 357
18-7948	FILTROS DE RECAMBIO DE 10 MICRAS Y KITS CON CAZOLETA DE DRENAJE	266, 336, 357
18-7949	FILTROS DE RECAMBIO DE 10 MICRAS Y KITS CON CAZOLETA DE DRENAJE	266
18-7951	KIT FILTROS DE 10 MICRAS CON CAZOLETA DE DRENAJE	266
18-7953	FILTRO COMBUSTIBLE	159
18-7953	SEPARADORES COMBUSTIBLE/ AGUA	336
18-7954	FILTRO ACEITE	293
18-7954	FILTRO ACEITE 4-CICLO FUERABORDA	294
18-7955	ELEMENTO FILTRO COMBUSTIBLE	267
18-7963	ARO TÓRICO	200
18-7965-1	KIT SEPARADOR 10 MICRONES COMPACTO	56, 158, 266
18-7966-1	FILTRO 10 MICRAS PARA MOTORES DE INYECCIÓN	265
18-79781	FILTRO COMBUSTIBLE	159
18-7979	FILTRO COMBUSTIBLE	57, 267
18-79799	FILTRO COMBUSTIBLE	267
18-79809	FILTRO COMBUSTIBLE	267
18-7981	FILTRO COMBUSTIBLE	57
18-7982-1	FILTRO 10 MICRAS PARA MOTORES DE INYECCIÓN	265
18-7982-2	FILTRO 10 MICRAS PARA MOTORES DE INYECCIÓN	265
18-7983-1	FILTRO 10 MICRAS PARA MOTORES DE INYECCIÓN	265
18-7983-2	FILTRO 10 MICRAS PARA MOTORES DE INYECCIÓN	265
18-7984-1	FILTRO 10 MICRAS PARA MOTORES DE INYECCIÓN	265
18-7985-1	FILTRO 10 MICRAS PARA MOTORES DE INYECCIÓN	265
18-7986-1	FILTRO 10 MICRAS PARA MOTORES DE INYECCIÓN	265
18-7987	SEPARADORES COMBUSTIBLE/ AGUA	336
18-79900	FILTRO VST	268
18-79901	FILTRO VST	268
18-79902	FILTRO VST	269
18-79903	FILTRO VST	269
18-79904	FILTRO VST	269
18-79905	FILTRO COMBUSTIBLE	267

Referencia	Descripción	Página
18-79907	FILTRO VST	268
18-79908	FILTRO COMBUSTIBLE	358
18-79909	FILTRO COMBUSTIBLE	358
18-79910	FILTRO COMBUSTIBLE	269
18-79950	KITS VST	269
18-79951	KITS VST	269
18-79952	KITS VST	269
18-79953	KITS VST	269
18-79954	KIT VST FILTRO & JUNTA	269
18-79955	KIT VST FILTRO & JUNTA	269
18-79956	KIT VST FILTRO & JUNTA	269
18-79957	KIT VST FILTRO & JUNTA	269
18-79961	FILTRO ACEITE	293
18-7997	FILTRO DE AIRE	58
18-79970	FILTRO COMBUSTIBLE	267
18-79971	FILTRO ACEITE	293
18-79972	ELEMENTOFILTRO COMBUSTIBLE	267
18-79973	FILTRO COMBUSTIBLE	267
18-79974	FILTRO ACEITE	293
18-79975	FILTRO ACEITE	293
18-79976	FILTRO ACEITE	293
18-79977	FILTRO COMBUSTIBLE	268
18-79978	FILTRO VST	269
18-79979	FILTRO COMBUSTIBLE	268
18-79980	FILTRO COMBUSTIBLE	268
18-79981	FILTRO COMBUSTIBLE	268
18-79982	FILTRO COMBUSTIBLE	268
18-79983	FILTRO COMBUSTIBLE	268
18-79984	FILTRO COMBUSTIBLE	268
18-79985	FILTRO COMBUSTIBLE	268
18-79986	FILTRO COMBUSTIBLE	268
18-79989	STICKS ARRASTRE	110, 221, 311, 345, 367, 378
18-7999	FILTRO DE AIRE	58
18-8002S	BOMBA COMBUSTIBLE MANUAL	271, 337, 376
18-8004	BOMBA MANUAL	160, 271, 337, 376
18-8005S	BOMBA COMBUSTIBLE	51, 52, 160, 270, 271, 337, 357, 376
18-8020	ABRAZADERA	376
18-8021	ABRAZADERA	376
18-8040	CODO DEPÓSITO	271
18-80402	CONECTOR COMBUSTIBLE	53
18-80403	ENSAMBLAJE DE LINEA DE COMBUSTIBLE DE LONG	357
18-80403	CONECTOR COMBUSTIBLE	358
18-80404	CONECTOR COMBUSTIBLE	339
18-80406	CONECTOR COMBUSTIBLE	358
18-80407	CONECTOR COMBUSTIBLE	358
18-80408	CONECTOR COMBUSTIBLE	358
18-80409	CONECTOR COMBUSTIBLE	337
18-80410	CONECTOR COMBUSTIBLE	53
18-80410	CONECTOR COMBUSTIBLE	376
18-80412	CONECTOR COMBUSTIBLE	53
18-80413	CONECTOR COMBUSTIBLE	271
18-80414	CONECTOR COMBUSTIBLE	271
18-80415	CONECTOR COMBUSTIBLE	271
18-80418	CONECTOR COMBUSTIBLE	337
18-80419	CONECTOR COMBUSTIBLE	337
18-80420	CONECTOR COMBUSTIBLE	358
18-80425	CONECTOR COMBUSTIBLE	337
18-8048	MANGUERA DE SANGRADO	160
18-8051	MANGUERA COMBUSTIBLE DOBLE	160
18-8052	MANGUERA COMBUSTIBLE	160
18-8055S	CONECTOR MANGUERA	271

Referencia	Descripción	Página
18-8056	CONECTOR COMBUSTIBLE	160
18-8062	CONECTOR COMBUSTIBLE	339
18-8063	CONECTOR DEPÓSITO	160
18-8068	CONECTOR COMBUSTIBLE	53
18-8069	CONECTOR COMBUSTIBLE	53
18-8071	CONECTOR COMBUSTIBLE	339
18-8072	CODO COMBUSTIBLE	160
18-8073	CONECTOR MANGUERA	51, 52
18-8074	CONECTOR MANGUERA	51, 52, 160
18-8075	CONECTOR COMBUSTIBLE	53
18-8076	CONECTOR MANGUERA	51, 52, 53, 270
18-8077	CONECTOR COMBUSTIBLE	53
18-8077-1	CONECTOR DEPÓSITO	270, 271
18-8078	CONECTOR DEPÓSITO	339, 376
18-8079	CONECTOR COMBUSTIBLE	339
18-8079	CONECTOR COMBUSTIBLE	376
18-8082	CONECTOR COMBUSTIBLE	53
18-8083	FUEL CONNECTOR	51, 52, 53
18-8085	CONECTOR COMBUSTIBLE	53
18-8087	CONECTOR COMBUSTIBLE	339
18-8089	CONECTOR COMBUSTIBLE	376
18-8090	CONECTOR COMBUSTIBLE	339
18-8091	CONECTOR COMBUSTIBLE	53
18-8092	CONECTOR COMBUSTIBLE	160
18-8226	FILTRO COMBUSTIBLE	358
18-8298	RETÉN	365
18-8299	RETÉN GOMA	365
18-8304	RETÉN ACEITE	215
18-8305	JUNTA RETÉN DIVISOR	94
18-8309	JUNTA RETÉN REGULADOR	94
18-8331	JUNTA TORNILLO DRENAJE	344
18-8334	RETÉN EJE HÉLICE	344
18-8335	KIT RETENES UNIDAD INFERIOR	346
18-8337	KIT RETENES UNIDAD INFERIOR	229, 346
18-8338	KIT RETENES UNIDAD INFERIOR	346
18-8339	KIT RETENES UNIDAD INFERIOR	346
18-8340	KIT RETENES UNIDAD INFERIOR	346
18-8341	KIT RETENES UNIDAD INFERIOR	346
18-8345	RETÉN ACEITE	347
18-8352	JUNTA CARBURADOR	194
18-8353	RETÉN ACEITE	200
18-8355	KIT RETENES CIGÜÑAL	185
18-8362-1	KIT INFERIOE SELLADO	367
18-8362-1	APLICACIÓN KIT DE SELLADO DE UNIDAD NFERIOR	367
18-8363	KIT INFERIOE SELLADO	367
18-8365	APLICACIÓN KIT DE SELLADO DE UNIDAD NFERIOR	367
18-8366	KIT SELLADO UNIDAD INFERIOR	367
18-8366	APLICACIÓN KIT DE SELLADO DE UNIDAD NFERIOR	367
18-8372	RETÉN	200
18-8373	KIT RETENES UNIDAD INFERIOR	346
18-8374	KIT RETENES UNIDAD INFERIOR	346
18-8375	RETÉN ACEITE	347
18-8378	RETÉN ACEITE	347
18-8380	KIT RETENES UNIDAD INFERIOR	345
18-8381	KIT RETENES UNIDAD INFERIOR	345
18-8382	KIT RETENES UNIDAD INFERIOR	116
18-8383	KIT RETENES	229
18-8384	KIT RETENES	229
18-8385	KIT RETENES	347
18-8386	KIT RETENES	347
18-8387	KIT RETENES UNIDAD INFERIOR	229
18-8400-9	TORNILLOS	274
18-8700	FILTRO ACEITE	294

Referencia	Descripción	Página
18-8866	BOMBA COMBUSTIBLE	49
18-8870	FILTRO ACEITE	343
18-8900	IMPULSOR	60
18-8905	KIT REPARACIÓN IMPULSOR	162
18-8906	IMPULSOR	163
18-8907	IMPULSOR	163
18-8910	IMPULSOR	272
18-8911	IMPULSOR	272
18-8920	IMPULSOR	376
18-8921	IMPULSOR	376
18-8922	IMPULSOR	376
18-8923	IMPULSOR	376
18-8924	IMPULSOR	376
18-8925	IMPULSOR	272
18-8953	TAPA SEPARADORA DE COMBUSTIBLE/ AGUA	266
18-8954	TAPA SEPARADORA DE COMBUSTIBLE/ AGUA	266
18-8956	ACOPLADOR	49
18-8957	VÁLVULA	49
18-8958	CONECTOR	49
18-9010	TOMA DE AGUA	110
18-9075	ESPACIADOR	110
18-9075	ESPACIADOR	277
18-9076	COLLAR	110
18-9076	COLLAR	277
18-9077	ARANDELA	110, 277
18-9078	ARANDELA ACERO INOXIDABLE	110, 277
18-9079	KIT ARANDELAS	110, 277
18-9079	KIT ARANDELA	277
18-9081	ALOJAMIENTO TAPA BOMBA AGUA	273
18-9082	ALOJAMIENTO TAPA BOMBA AGUA	273
18-9125	KIT ABRAZADERA	162
18-9219	EJE INFERIOR	218
18-9800	TESTER COMPRESIÓN	32
18-9801	MULTI METER/DVA TESTER	32
18-9802	LUZ CRONOMETRAJE	32, 142, 259, 334
18-99000	JUNTA COLECTOR ESCAPE	299
18-99001	JUNTA DE CÁRTER SUPERIOR	299
18-99002	JUNTA COLECTOR ESCAPE	299
18-99003	JUNTA ESCAPE	299
18-99004	JUNTA DE CÁRTER SUPERIOR	299
18-99005	JUNTA SILENCIADOR	299
18-99006	JUNTA COLECTOR ESCAPE	299
18-99008	JUNTA COLECTOR ESCAPE	300
18-99009	JUNTA SILENCIADOR	300
18-99010	JUNTA COLECTOR ESCAPE	300
18-99012	JUNTA COLECTOR ESCAPE	300
18-99013	JUNTA DE CÁRTER SUPERIOR	300
18-99014	JUNTA COLECTOR ESCAPE	300
18-99015	JUNTA DE CÁRTER SUPERIOR	300
18-99016	JUNTA COLECTOR ESCAPE	300
18-99017	JUNTA SILENCIADOR	300
18-99018	JUNTA COLECTOR ESCAPE	300
18-99019	JUNTA COLECTOR ESCAPE	300
18-99020	JUNTA SILENCIADOR	300
18-99021	JUNTA COLECTOR ESCAPE	300
18-99022	JUNTA DE CÁRTER SUPERIOR	300
18-99023	JUNTA COLECTOR ESCAPE	300
18-99024	JUNTA COLECTOR ESCAPE	300
18-99025	JUNTA DE CÁRTER SUPERIOR	300
18-99026	JUNTA SILENCIADOR	300
18-99027	JUNTA CÁRTER	300
18-99028	JUNTA CÁRTER	300
18-99030	JUNTA DE CÁRTER SUPERIOR	301

Referencia	Descripción	Página
18-99032	JUNTA COLECTOR ESCAPE	301
18-99033	JUNTA COLECTOR ESCAPE	301
18-99034	JUNTA COLECTOR ESCAPE	301
18-99037	JUNTA COLECTOR ESCAPE	301
18-99038	JUNTA COLECTOR ESCAPE	301
18-99039	JUNTA COLECTOR ESCAPE	301
18-99040	JUNTA DE CÁRTER SUPERIOR	301
18-99045	JUNTA DE CÁRTER SUPERIOR	301
18-99046	JUNTA DE CÁRTER SUPERIOR	301
18-99047	JUNTA SILENCIADOR	301
18-99048	JUNTA CULATA	297
18-99049	JUNTA	301
18-99050	JUNTA ADMISIÓN	301
18-99051	JUNTA TAPA VÁLVULA	301
18-99052	JUNTA TAPA	301
18-99053	JUNTA ADMISIÓN	301
18-99054	JUNTA ADMISIÓN	301
18-99055	JUNTA COLECTOR	301
18-99056	JUNTA BASE	301
18-99057	JUNTA TAPA VÁLVULA	301
18-99059	JUNTA CULATA	297
18-99060	JUNTA CULATA	297
18-99061	JUEGO JUNTAS	294
18-99062	JUNTA CULATA	297
18-99063	JUNTA CÁRTER INFERIOR	301
18-99064	JUNTA ADMISIÓN	302
18-99066	JUNTA ADMISIÓN	302
18-99067	JUNTA ADMISIÓN	302
18-99068	JUNTA TAPA RESPIRADERO	302
18-99069	JUNTA BASE	302
18-99070	JUNTA CÁRTER	302
18-99071	JUNTA	302
18-99072	JUNTA ESCAPE	302
18-99073	JUEGO JUNTAS	294
18-99074	JUNTA BASE	302
18-99075	JUNTA TAPA	302
18-99076	JUNTA BOMBA DE AGUA	302
18-99078	JUNTA	302
18-99079	JUNTA DE CÁRTER SUPERIOR	302
18-99080	JUNTA ADMISIÓN	302
18-99082	JUNTA BOMBA DE AGUA	302
18-99083	JUNTA BOMBA DE AGUA	302
18-99084	JUNTA ESCAPE	302
18-99085	JUNTA ESCAPE	302
18-99086	JUNTA BOMBA DE AGUA	302
18-99087	JUNTA CÁRTER INFERIOR	302
18-99088	JUNTA TAPA	302
18-99089	JUNTA ESCAPE	303
18-99091	JUNTA	303
18-99092	JUEGO JUNTAS	294
18-99093	JUEGO JUNTAS	294
18-99094	JUNTA CULATA	297
18-99095	JUNTA BASE	303
18-99096	JUNTA	303
18-99097	JUEGO JUNTAS	294
18-99098	JUNTA ADMISIÓN	303
18-99099	JUNTA TAPA VÁLVULA	303
18-99100	JUNTA	303
18-99101	JUNTA ESCAPE	303
18-99102	JUNTA BASE	303
18-99103	JUEGO JUNTAS	294
18-99104	JUEGO JUNTAS	294
18-99105	JUNTA ADMISIÓN	303
18-99106	JUNTA TAPA VÁLVULA	303
18-99107	JUNTA ESCAPE	303

Referencia	Descripción	Página
18-99108	JUNTA TAPA VÁLVULA	303
18-99109	JUNTA	303
18-99110	JUNTA ADMISIÓN	303
18-99111	JUNTA ADMISIÓN	303
18-99112	JUNTA ESCAPE	303
18-99113	JUNTA ESCAPE	303
18-99114	JUNTA ESCAPE	303
18-99115	JUNTA BASE	303
18-99116	JUNTA BOMBA AGUA	303
18-99117	JUEGO JUNTAS	294
18-99118	JUNTA CARBURADOR	303
18-99119	JUNTA BASE	303
18-99120	JUNTA TERMOSTATO	303
18-99121	JUNTA ADMISIÓN	304
18-99122	JUNTA ADMISIÓN	304
18-99123	JUNTA	304
18-99124	JUNTA TERMOSTATO	304
18-99125	JUNTA ADMISIÓN	304
18-99126	JUNTA ADMISIÓN	304
18-99127	JUNTA TERMOSTATO	306
18-99128	JUNTA ESCAPE	304
18-99129	JUNTA ESCAPE	304
18-99130	JUNTA ESCAPE	304
18-99132	JUNTA	304
18-99133	JUNTA	304
18-99134	JUNTA	304
18-99135	JUNTA ESCAPE	304
18-99136	JUNTA ADMISIÓN	304
18-99137	JUNTA ESCAPE	304
18-99138	JUNTA BOMBA AGUA	304
18-99139	JUNTA ADMISIÓN	304
18-99140	JUNTA CULATA	304
18-99141	JUNTA TAPA	304
18-99142	JUNTA TERMOSTATO	304
18-99143	JUNTA VÁLVULA	304
18-99144	JUNTA TAPA MEZCLADO	304
18-99145	JUNTA CARBURADOR	304
18-99146	JUNTA CAMARA DE FLOTADOR	262
18-99147	JUNTA BOMBA COMBUSTIBLE	304
18-99148	JUNTA TAPA ESCAPE	304
18-99149	JUNTA BOMBA AGUA	305
18-99150	JUNTA DE CÁRTER SUPERIOR	305
18-99151	JUNTA DE CÁRTER SUPERIOR	305
18-99152	JUNTA CÁRTER INFERIOR	305
18-99175	JUEGO DE JUNTAS BLOQUE MOTOR	296
18-99176	JUEGO DE JUNTAS BLOQUE MOTOR	296
186029Zinc	ÁNODO	227
187915-1	FILTRO ACEITE	186
603041 AL 18-6241 Mag 009354 Zinc	ÁNODO	366
603048 AL 009464 Zinc	ANODOS	110
603048 AL 009464 Zinc	ÁNODO	366
603113 AL	ÁNODO	309
603113 AL	ÁNODO	366
603114 AL	ÁNODO	309
603114 AL 009114 Zinc	ÁNODO	366
603115 AL	ÁNODO	309
603116 AL	ÁNODO	309
603117 AL	ÁNODO	309
603118 AL	ÁNODO	310
603119 AL	ÁNODO	309

Referencia	Descripción	Página
603120 AL 025468 Zinc	ÁNODO	309
603121 AL 025841 Zinc	ÁNODO	309
603122 AL	ÁNODO	310
603128AL	ÁNODO	227
603129AL	ÁNODO	227
603130AL	ÁNODO	227
60313AL	ÁNODO	227
603151AL	ÁNODO	227
603152AL	ÁNODO	227
603158 AL 18-6156M	KIT ANODOS	110
603159 AL 18-6157 M	KIT ANODOS	110
603170 AL	ÁNODO	309
603171 AL	ÁNODO	309
603172 AL	ÁNODO	309
603174 AL	ÁNODO KIT	309
603175 AL	ÁNODO	309
603176 AL 025455 Zinc	ÁNODO	309
MP28860	HOMBRE AL AGUA	251
MP28870 MP28872	CABLE Y CLIP HOMBRE AL AGUA	144
MP28880	CABLE HOMRE AL AGUA	144
MP28890	HOMBRE AL AGUA	144
MP28900	CABLE	145
MP39100	LLAVE ENCENDIDO	144
MP39160	INTERRUPTOR PULSADOR MOMENTANEO	251
MP39760	LLAVE ENCENDIDO	144
MP39830	LLAVE ENCENDIDO	144
MP41000	LLAVE ENCENDIDO	30
MP41070-2	LLAVE ENCENDIDO	30
MP51010 MP51012	INTERRUPTOR ENCENDIDO	333
MP51020	LLAVE ENCENDIDO	251
MP51030	LLAVE ENCENDIDO	251
MP51040	LLAVE ENCENDIDO	251
MP51050	LLAVE ENCENDIDO	251
MP51090 MP51092	LLAVE ENCENDIDO	30
MP52000 MP52002	LLAVE ENCENDIDO	30

MARCAS REPRESENTADAS



INSTALACIONES



Central GAVA:
Miquel Servet 19,
"Polígono Industrial Camí Ral"
08850 Gavà. - BARCELONA
T. 936 333 680 - F. 936 625 733
info@pronautic.net

Horario:
Todo el año: de 9h. a 18h.



Delegación GIRONA:
La Selva 19, "Pol Industrial El Pla"
17486 Castello d'Empuries - GIRONA
T. 972 749 059
girona@pronautic.net

Horario:
Abril a septiembre: de 9h. a 13h y 14h. a 19h
Resto del año: de 9h. a 13h y 14h. a 18h

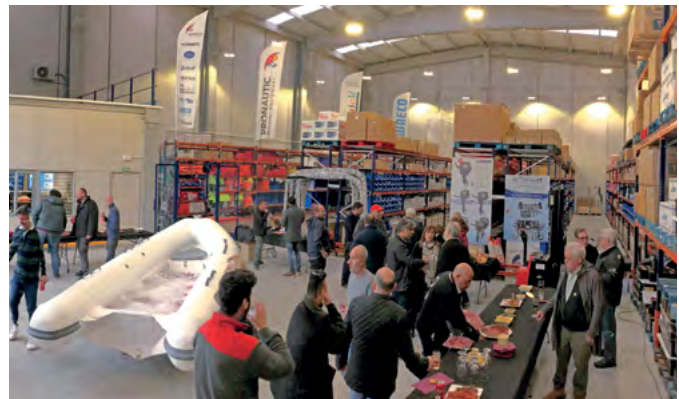

Delegación PALMA MALLORCA:
Gremi Corredors 22
Centre Tramuntana Nave 7 Pol. Ind.
07009 Palma de Mallorca - Son Rossinyol
T. 871 004 828
mallorca@pronautic.net

Horario:
Todo el año: de 8h. a 17h.





PRONAUTIC
MARINE EQUIPMENT

www.pronautic.net

Central GAVA:

Miquel Servet 19,
Polígono Industrial Camí Ral
08850 Gavà. - BARCELONA
T. 936 333 680 - F. 936 625 733
info@pronautic.net

Contactos Gava:

Pedidos / Comercial:
ventas@pronautic.net

Contabilidad / Administración:

T. 936 629 208
administracion@pronautic.net

Compras:

T. 936 333 681
compras@pronautic.net

Recambios:

T. 936 333 681 Ext.: 3215
albert@pronautic.net

Delegación GIRONA:

La Selva 19
Pol Industrial El Pla
17486 Castello d'Empuries - GIRONA
T. 972 749 059
girona@pronautic.net

Delegación PALMA DE MALLORCA:

Gremi Corredors 22
Centre Tramuntana Nave 7 Pol. Ind.
07009 Palma de Mallorca - Son Rossinyol
T. 871 004 828
mallorca@pronautic.net